

3D Architect Home Designer

Getting Started Guide

Produced and published in the UK by Eleco Software Limited

© 2016 Eleco Software plc. All rights reserved.

The software and hardware names and labels used in this document are generally protected trademarks of their respective owners.

All data and programs described in this document were compiled and/or arranged by the authors with utmost care and reproduced under adherence to proper and effective control measures. Nevertheless, there may be errors. Therefore, Eleco Software Limited would like to point out that neither a warranty, legal responsibility, nor any liability for consequences of using the software or documentation can be ascribed to the publisher, or the distributor.

No part of this document may be reproduced, stored in a retrieval system, or transmitted by any means, electronic, mechanical, photocopying, recording or otherwise, without the prior permission of the publisher.

Contents

Welcome.....	3
3D Architect Home Designer: The Basics	3
<i>Understanding the Interface.....</i>	<i>3</i>
Horizontal icon bar, top:.....	4
Tool menu bar, left (<i>What bar</i>):	4
Tool options catalogue, right:	5
Horizontal status bar, bottom:	5
Switching different displays on and off	6
Selecting tools	6
Drag and drop.....	6
Basic mouse and keyboard controls.....	6
<i>2D Construction mode and 3D Furnishing mode</i>	<i>8</i>
Getting Started.....	8
<i>Program Start / General</i>	<i>8</i>
<i>Adding Construction Elements.....</i>	<i>9</i>
Drawing external walls using numeric input	9
Drawing parallel walls using numeric input	14
Drawing single walls	18
Drawing walls at fixed angle	20
Editing tools: Mitre walls (L) option	22
Placing guidelines	24
Window and door placement	26
Assigning room names	31
Adding staircase to your plan.....	31
Creating additional floors.....	34
Selecting and deleting construction elements	37
Adding a roof to building	38
Using in-line measurements.....	42
Adding skylights to existing roof	45
<i>Furnishing Your Project.....</i>	<i>46</i>
Objects	46
Materials	48
Applying materials to objects	50
Scaling a texture.....	50
Material area.....	51
Apply lighting and shadow effects	52

Welcome

This guide has been created for users of all levels and is ideal for anyone new to 3D Architect Home Designer software, experienced users looking for some suggested methods or for prospective users who want to see how easy 3D Architect Home Designer can be.

This guide will not teach you architecture, interior design, drawing or building methods, it will teach you how to start using 3D Architect Home Designer. After practice, you will soon realise how effective 3D Architect Home Designer is as a design and visualisation tool.

Please note that this guide will only teach you the basics of 3D Architect Home Designer. If you need more details on a particular function in 3D Architect Home Designer, you should refer to the help system in the software.

The screenshots in this guide have been produced through different stages of development and whilst still being appropriate to the described function, the appearance may vary slightly.

Note: 3D Architect Home Designer is powered by Arcon Evo software. As a result, you might find references to Arcon Evo throughout the software and documentation.

3D Architect Home Designer: The Basics

If you are new to 3D Architect Home Designer you should work through this chapter first before you embark on the main tutorial to get you started.

While using 3D Architect Home Designer you will find many things in common with other Windows programs. Of course, the individual program functions and details are different, being adapted to the special needs of design and planning. If you have already worked with other Windows programs, you know the basic operation of the Windows user interface. You know, for example, how to select a menu option from a menu, how to open and minimise windows, and how to launch and exit a program.

Before you get started in 3D Architect Home Designer, we'll first explain a little about the program interface and the two main modes you will be working in.

Understanding the Interface

As with other Windows programs 3D Architect Home Designer consists of a menu bar at the top of the screen for convenient access to various operations within the program.

Besides the menu bar are the vertical and horizontal toolbars. These bars consist of arranged sets of icons, which serve to access program functions or change the view. The individual icons on the bars behave similarly to icons in Windows programs. By left-clicking them you can activate or deactivate functions.

In the horizontal bar that appears at the top, under the classic menu bar, you'll find icons, which are used throughout the whole project. Tabs for accessing component properties also become visible on selection of construction elements.

Horizontal icon bar, top:



The horizontal bar comprises of an arrangement of general functions as follows:

- *Open file*
- *Save file*
- *Undo & Redo*
- *Print*
- *Export image*
- *Zoom*
- *Show all*
- *Toggle between 2D and 3D and Plan mode*
- *Move texture*
- *Material/texture picker*
- *Active layer display*
- *Active floor display*
- *Tool options*
- *Catalogue on/off*
- *Quick help*
- *Help topics*

Tabs for accessing component properties also become visible on selection of construction elements.

Tool menu bar, left (*What bar*):

Besides the horizontal bar, 3D Architect Home Designer uses vertical bars, which are always arranged to the left and right-hand side of screen. In Construction mode, the left vertical bar lets you select components, construction elements and their input and editing options. Both the upper horizontal and the left vertical bars are always displayed, in both 3D Furnishing mode and Construction mode. But the icons in them change or become inactive depending on the mode. Hovering your mouse cursor over a particular function in bar a fly-out menu of recently used tools will appear for selection.

- *Selection tool (select elements)*
- *Tools (such as copying, moving, mirroring)*
- *Walls*
- *Rooms*
- *Doors*
- *Windows*
- *Stairs*
- *Ceiling & Cut-outs*
- *Balconies & Platforms*
- *Supports & Chimneys*
- *Roofs*
- *Dormers*
- *Skylights*
- *Objects*



- *Materials*
- *Material area*
- *Dimensions*
- *Text*
- *2D drawing tools*
- *Symbols library*
- *Current selection*

In Construction mode, there is also a second vertical bar that appears when selecting certain tools. Where the main left-hand vertical bar lets you select what to input (*What bar*), a second smaller bar also appears that lets you decide how to input (*How bar*) the desired element. For example, selecting a window element will display a set of icons in bar for positioning e.g. freely, midway or at a set distance in wall.



Tool options catalogue, right:

To the right of the screen you will find the catalogue panel. This catalogue display will vary depending on what mode you are in and what function you are currently using. By left-clicking a tool from the set of icons at the left-hand side of screen (*What bar*), a list of icons/folders will appear in the catalogue. Here you can left-click individual tools to use in your project and depending on the tool selected, a second bar (*How bar*) also displays in the catalogue letting you decide how to input the desired element.

The right vertical bar contains catalogues for the current function. If no function has been selected then the Tools catalogue will be displayed.

- *Modify walls*
- *Trim/Bevel*
- *Segments/Breaks*
- *Fills/Outlines/Hatching*
- *Move/Rotate*
- *Copy*
- *Polygons/Splines*
- *Misc*
- *Selection*

TIP: You can switch the catalogue display on/off by clicking the following icon in the horizontal bar.

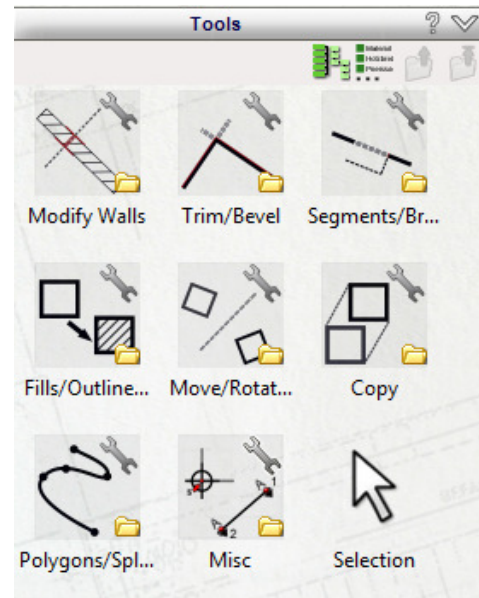

Horizontal status bar, bottom:

The horizontal bar at the bottom of screen is the status bar which includes all available functions for quick access.

The status bar also displays element specific tooltips on selection of some tools e.g. placing polygonal walls.

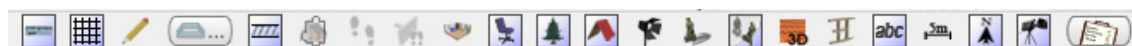

- *Ruler on/off*
- *Grid on/off*

- *Manage layers*
- *Hatching on/off*
- *2D View background overlay on/off*
- *Walkthrough*
- *Collision control during walk through*
- *Hide facing walls*
- *Interior objects on/off*
- *Exterior objects on/off*
- *Roofs on/off*
- *Light source display*
- *Shadow display*
- *Reflections display*
- *Use 3D textures*
- *Timber construction on/off*
- *Room labels on/off*
- *Edge dimensions on/off*
- *North point on/off*
- *Camera on/off*
- *Sketch (blur)*

TIP: You can configure the status bar display by adding or removing all available functions. To do this, click the following icon. In this same dialogue box, you can also rearrange the order of the icon display on the status bar.



Switching different displays on and off

The **Display** menu allows you to decide what parts of the screen (catalogue, numeric input, toolbar, construction tools, status bar) you want visible. This is particularly useful for freeing up some space on drawing sheet as and when you need to. For example, when drawing in 2D Construction mode you might not have a use for numeric input so therefore want to temporarily turn this display off.

Selecting tools

To select a tool from the relevant tool bar, menu or catalogue, move your cursor over the required option and left-click (click the left mouse button once). If the tool you are using has sub options, these will normally be presented on a fly-out menu when you hover your mouse over the icon.

When referring to tool options in the catalogue area, those icons identified with a small windows folder symbol can be accessed by double left-clicking to reveal the subset of options.

Drag and drop



For ease of use, 3D Architect Home Designer employs the drag-and-drop concept to many of the programs tools. This enables you to select an element (often from the Tool Options Catalogue) by left-clicking the mouse button. Then drag the element to the desired location on the page and left-click the mouse button again to drop the element into that location.

In addition to the standard use of drag and drop, elements which require a start and end point to be defined (e.g. walls) will make use of left-click to place the first point (i.e. the start point for a wall) and then left-click again to set the end point.



Basic mouse and keyboard controls

In 2D Construction mode and 3D Furnishing mode you can use various mouse and keyboard controls for zooming, viewing from all angles, moving about screen and walkthroughs.

2D Construction mode

- **Pressed right mouse button**
Shifts the floor plan view in the window when moving mouse
- **Mouse wheel**
Allows you to zoom in and out to selection
- **Left mouse button and selection tool** 
Use to select tools, menus and elements. Can also be used for zooming by selecting this in Tool Options

- **Right mouse button**
Opens available context menu

3D Furnishing mode

- **Pressed right mouse button**
Rotate and view 3D building from every side when moving mouse
- **Pressed right mouse button and Shift key**
Shifts 3D building from side to side when moving mouse
- **Pressed right mouse button and Ctrl key**
Rotate 3D building around reference point when moving mouse
- **Mouse wheel**
Allows you to zoom in and out to selection
- **Left mouse button and selection tool** 
Use to select tools, menus and elements. Can also be used for zooming by selecting this in Tool Options

- **Right mouse button**
Opens available context menu
- **Walkthrough mode** 
Pressed left mouse button and move mouse in direction to speed up walkthrough
Pressed left mouse button, Shift key and move mouse in direction to increase speed



Move forwards



Move backwards



Move forward left



Move forward right



Move left



Move right



Turn left



Turn right

2D Construction mode and 3D Furnishing mode

A principle concept of 3D Architect Home Designer is operating in two different modes - Construction and 3D Furnishing mode. When you start a new project, you automatically start in Construction mode.

In Construction mode you always operate in a 2D Plan view and in this mode you enter all structural elements for your building. These include, for example, walls, windows, doors, roofs, and chimneys. In 3D Furnishing mode you place your objects, such as furniture and accessories. You can also change the appearance of your 3D model, for example, choosing a wall or floor finish. It's often easier to place furniture items in top view e.g. for laying out kitchen units. Therefore, Construction mode also lets you place objects directly on to plan. There is also an optional Plan mode. In this mode, you can layout your 2D plans, elevations and 3D views on to one sheet. You can toggle between each mode using the following icons in the horizontal toolbar.

When you have all your floor plans drawn up there is an additional mode for laying out your floor plans together with elevations and section views. This is called Plan mode and can be accessed by clicking the highlighted icon below. The Plan mode provides even greater control of your layouts, enabling you to produce single sheets containing multiple views and floor plans. This is ideal for producing planning applications.



Getting Started

Program Start / General

When you first start 3D Architect Home Designer the **Start Assistant** appears. Select **Start new blank project** and click **Finish**.

A border and title block will appear on the drawing sheet. At any point you can hide or delete these in the **Layers** drop down list > **Manage Layers**. Almost all buttons are activated on the program interface. If you move your mouse cursor over a function, a tooltip containing a short description of each feature appears:

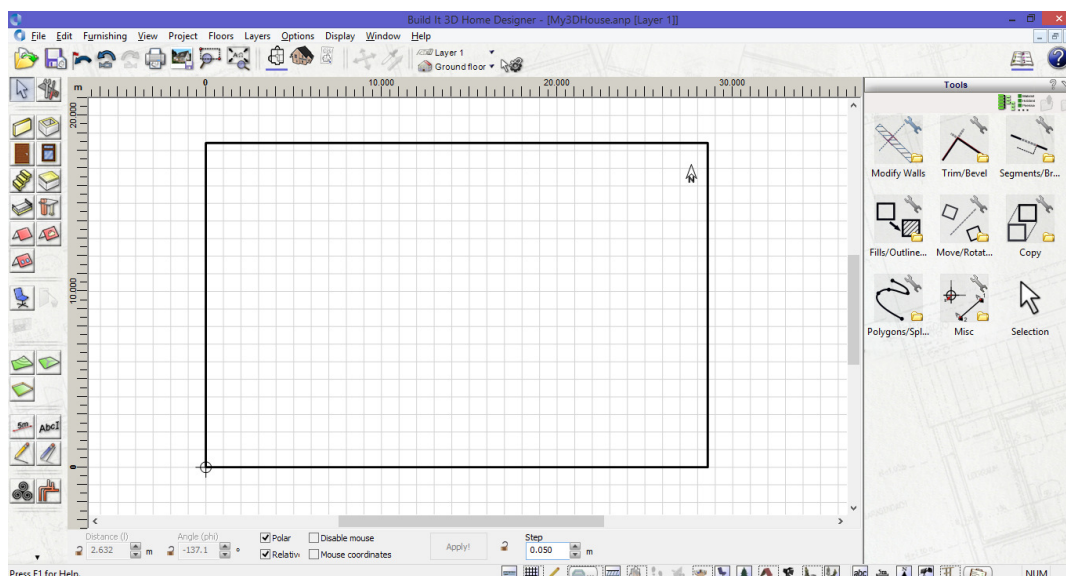

An empty project has the following default properties:

Unit:	Metre
Sheet size:	A4 - Landscape format
Scale:	1:100
Grid spacing X/Y:	1.000 m
Title block/ Drawing frame	Yes

TIP: You can change project settings before selecting **Create a new project** using **Assistant** under the menu item **Project > Project Properties**.

Adding Construction Elements

In this tutorial we will start on the ground floor and guide you through some of the basic functions required to draw a simple bungalow home, with stairs leading in to attic space to give you the following end result.

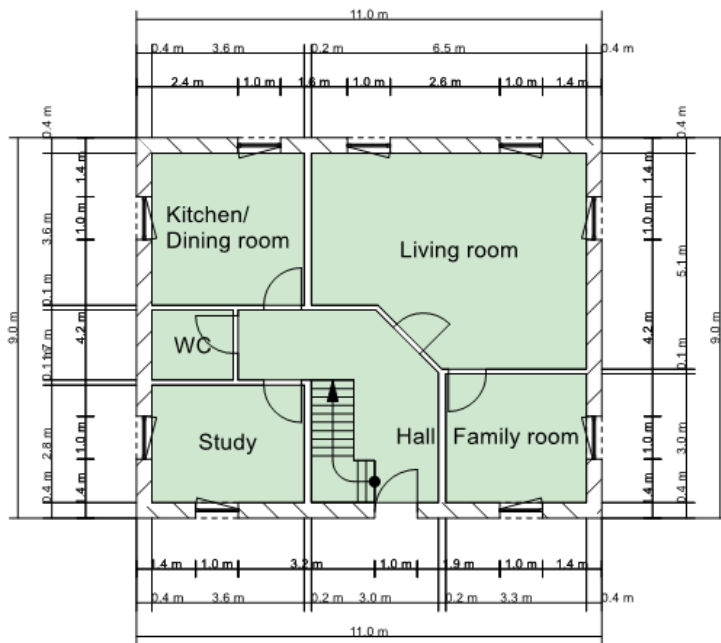

Drawing external walls using numeric input

1. We will start by entering external walls. First left-click the **Wall** icon in the left vertical bar. This will display a number of different folders for walls and beams in the catalogue panel on the right-hand side of screen. Double-click the **Walls** folder and select **Exterior wall (thick)** from the options available. You can also access recently used wall types from the fly-out menu that appears when you place your cursor over the **Walls** icon in the main left-hand toolbar.

Selecting a 'Wall' element will display a selection of tabs in the top horizontal bar for accessing component properties.

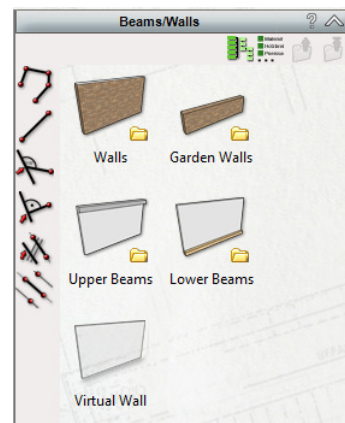

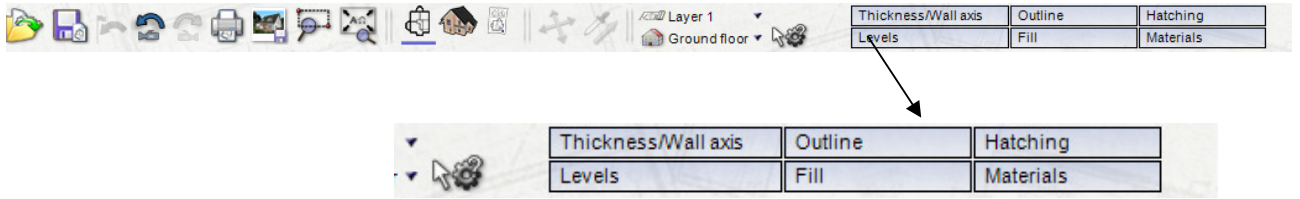

In this example we will continue with the default properties.

TIP: Under the **Tool Options** you can change parameters specific to that tool for example setting the distance from reference point for placing windows.



TIP: You can turn the grid display on and off under the menu option **View > Grid** or from the display icon on the bottom toolbar:



2. Furthermore, when selecting a 'Wall' element an additional vertical bar (*How bar*) appears. This bar determines the input method of the construction element by using the following:



- Polygonal walls
- Single wall
- Angled wall
- Wall at right angle
- Parallel wall
- Wall midway
- Round off walls

TIP: This structure also works with other construction elements i.e. where the main left-hand vertical bar lets you select what to input (*What bar*), the second smaller bar lets you decide how to input (*How bar*) the desired element.



In this exercise we will draw walls using the first input option **Polygonal walls** and **Numeric input**.

3. Set the start reference point of first external wall by left-clicking at the bottom-left of the drawing sheet:

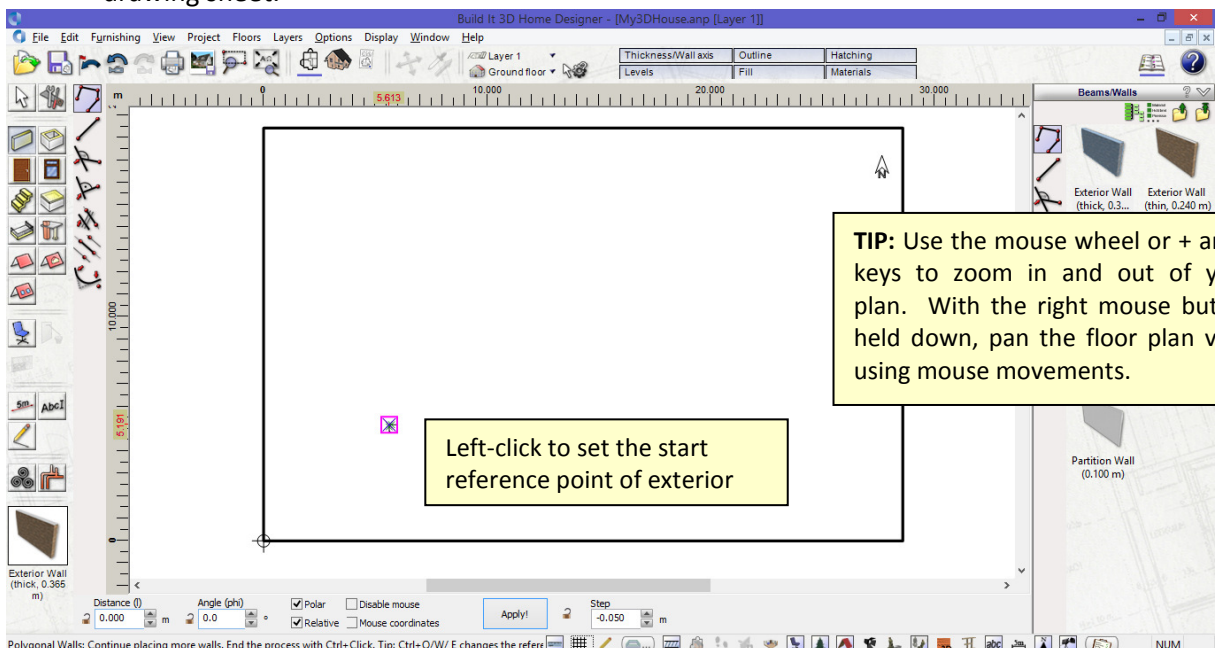

3D Architect Home Designer

- Next, drag the mouse vertically upwards. The wall to be created is attached to the mouse pointer. The inside edge of wall will highlight red. This wall side highlighted red is relevant to the wall length. In this example we will be entering the length of the outside edge of wall and to do this we need to determine the corresponding axis of the wall.
- Before placing walls in position, use the key combination **Ctrl + W** to toggle between the wall edges and wall axis. This lets you define which wall edge to place in relation to reference point e.g. the inside edge of wall, centre line of wall or outside edge of wall. Try pressing this key combination a few times to see the effect on screen. Use **Ctrl + W** to select the outside edge of wall for setting the length.
- With the numeric input bar enabled at the bottom of screen (menu **Display > Numeric input**), use the **Tab** key to select the **Distance (l)** field. Now overwrite the current value with **9m** and confirm the intermediate input of this wall section by pressing **Enter** on your keyboard or by clicking the **Apply** button on numeric bar.

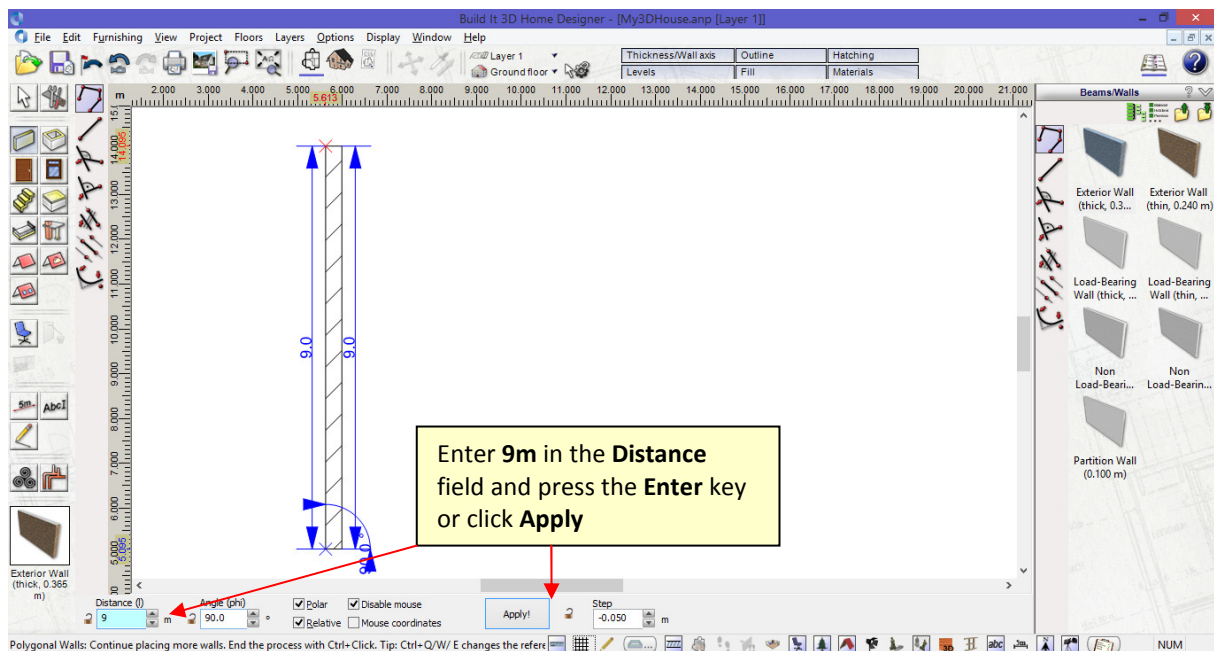

3D Architect Home Designer

- Now drag the mouse horizontally to the right. Enter **11m** in the **Distance (l)** field and confirm by pressing the **Enter** key or clicking **Apply**.

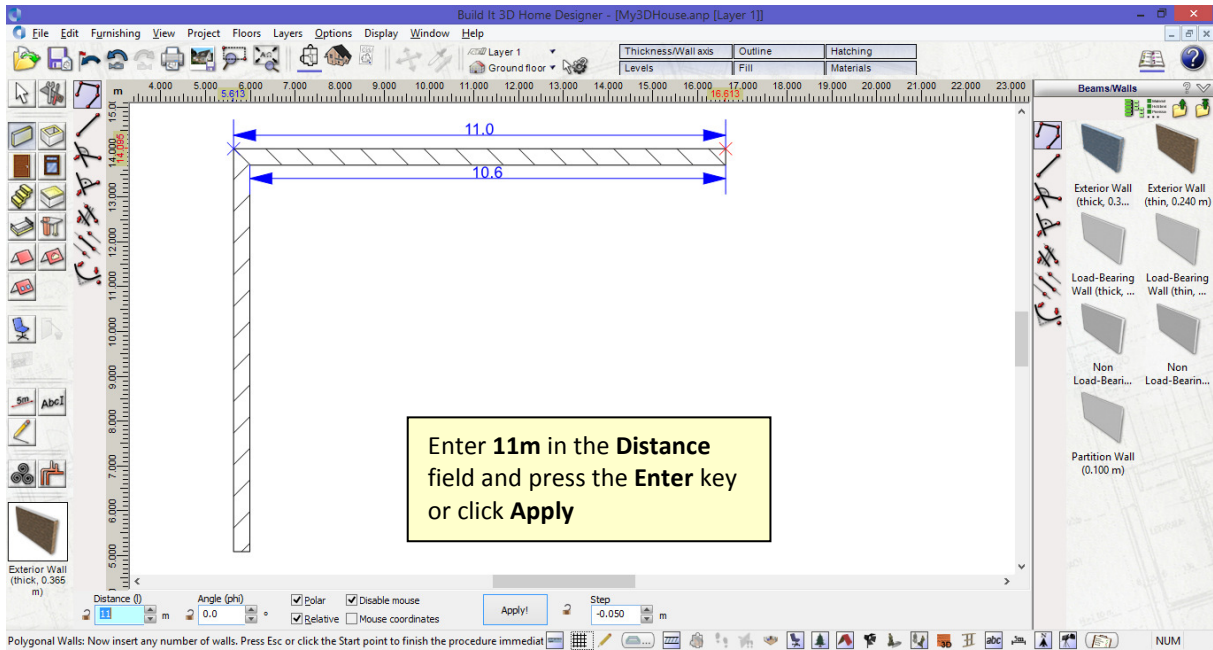

- Proceed by inputting the next wall as follows:

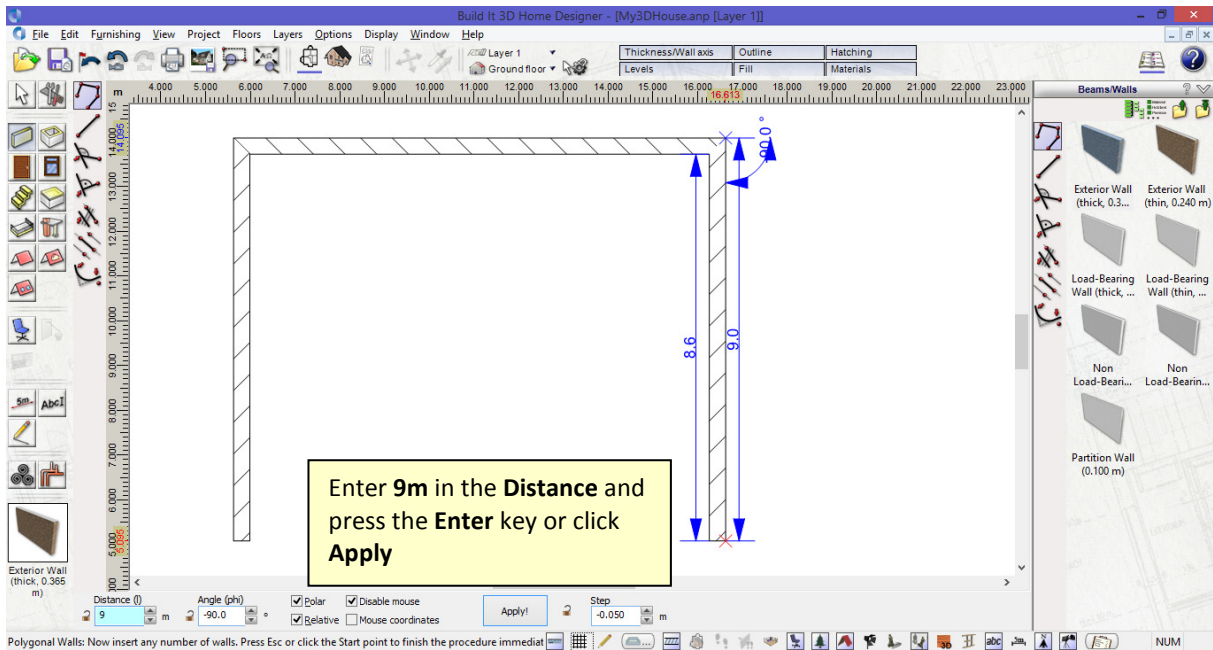

3D Architect Home Designer

- Complete the final external wall by left-clicking the start point. Pressing the **Esc** key will close the wall element function.

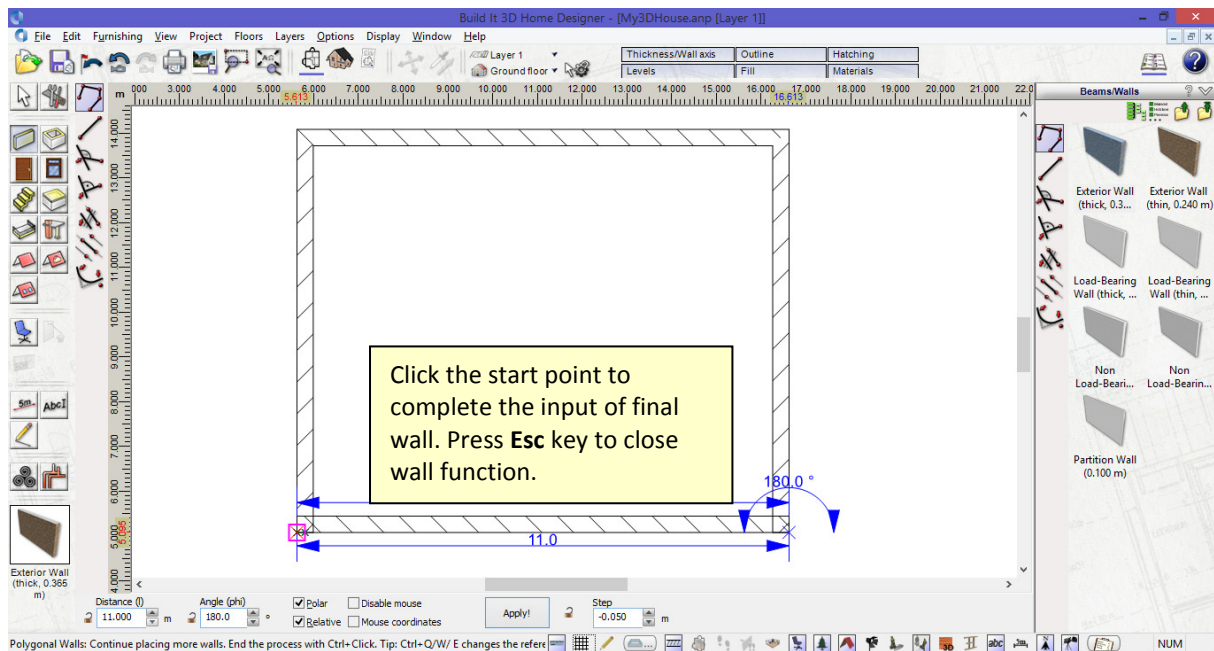

- You will notice that when your final wall connects back to your start point, the room is automatically labelled *Room 1*. This is an important part of the checking process when drawing in 3D Architect Home Designer. The room label confirms that all of your walls connect, with no gaps or spaces, to form a fully contained room. Once walls connect like this they are a room, which means that the floor and ceiling are created. If the walls do not connect, then no floor or ceiling will be added. Automatic room labels can be changed to more meaningful names later on in project - see section 'Assigning room names' and can be switched on/off in your project. There is also a 'Text' tool available for adding own labels / notes to individual rooms and to parts of drawing.

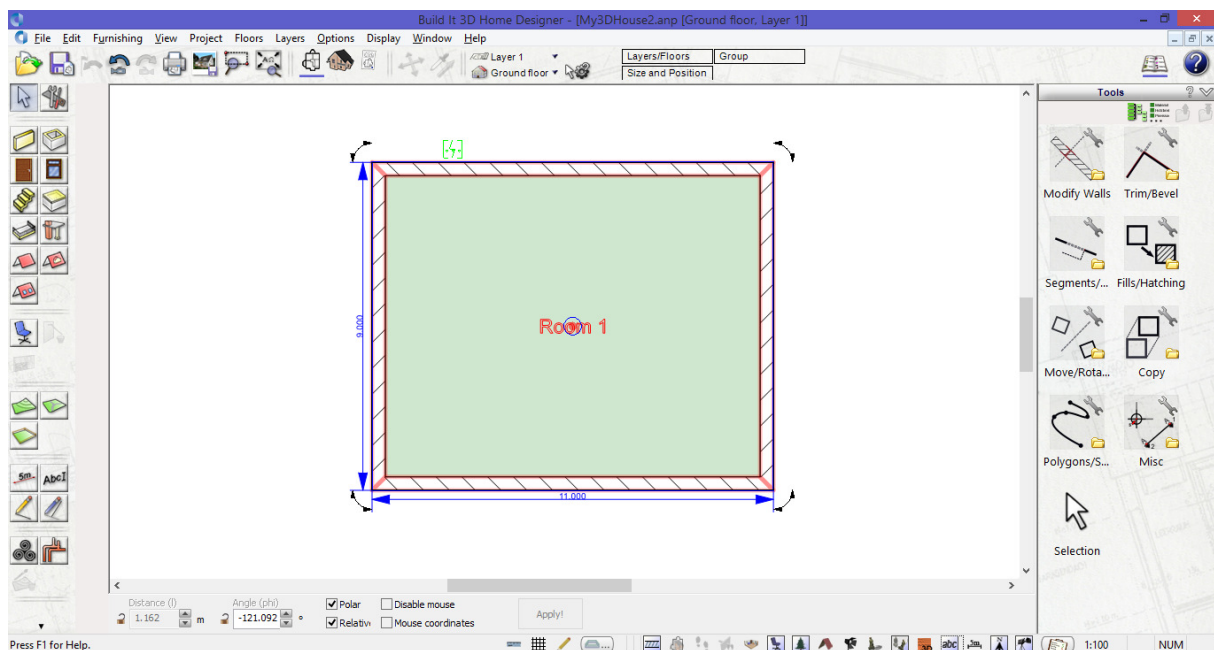

When using **Polygonal** input method for walls, by default the walls are grouped together when entered. This means that you will be unable to modify individual walls until they are ungrouped. To ungroup walls, select a wall in group and click on the ungroup symbol below. You can also ungroup through the 'Edit' menu.

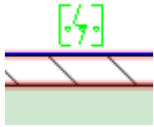

TIP: You can change the default so that walls are not always grouped when using polygonal input method. First select wall type and then click **Polygonal walls** icon. Now select the **Tool Options** and in the dialogue box that appears select the option for entered walls as '**Do not group**'.



11. At this point please save your project:

Under the menu item **File > Save As** you can enter a location and filename for the project e.g. *My3DHouse01.anp*.

Note that all 3D Architect Home Designer project files end with the suffix **.anp**

TIP: It is useful to save your project at different stages, so a regular save of e.g. *My3DHouse01.anp*, and *My3DHouse002.anp* etc will mean that you can always return to a known project state.

Drawing parallel walls using numeric input



In this next section we will guide you through the process of placing parallel walls using numeric input.

1. Enable the wall function again and this time we will be selecting a wall type from the catalogue on the right-hand side of screen. The catalogue consists of a selection of folders and subfolders that can be opened by double-clicking. Items in the catalogue can be displayed as a detailed list and also expanded so that all items are listed together outside their folders. There are also icons for navigating the folder structure.

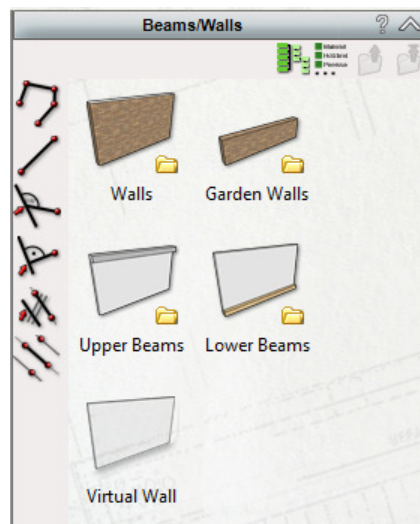

3D Architect Home Designer

2. Double-click the **Walls** folder and select the wall type **Interior wall (medium)** and then select the input type **Parallel Wall (in How bar)** from within the catalogue or from the left-side of screen.

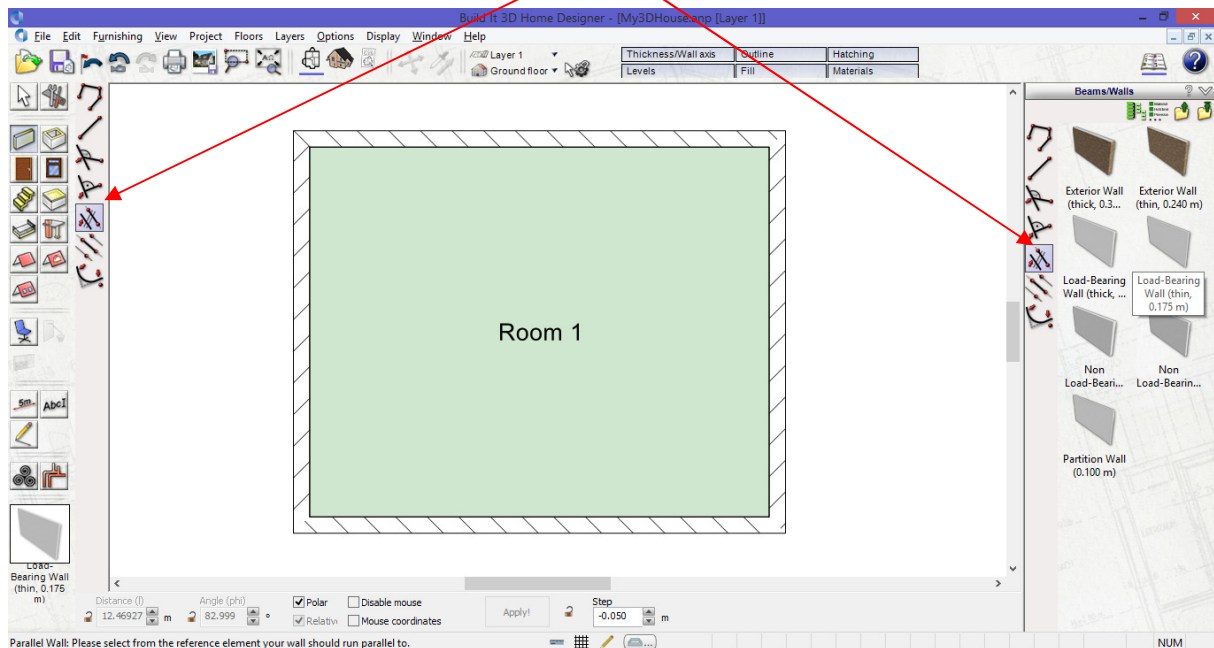

3. Move the mouse cursor over the reference line/element (in this example, the inner edge of left wall) you would like the new wall to be drawn parallel to. The cursor will snap to the reference line/element and highlight in red (see below). Select it by left-clicking and in the **Tool Options** dialogue box that appears, enter a distance of **3.6m** and click **OK**.

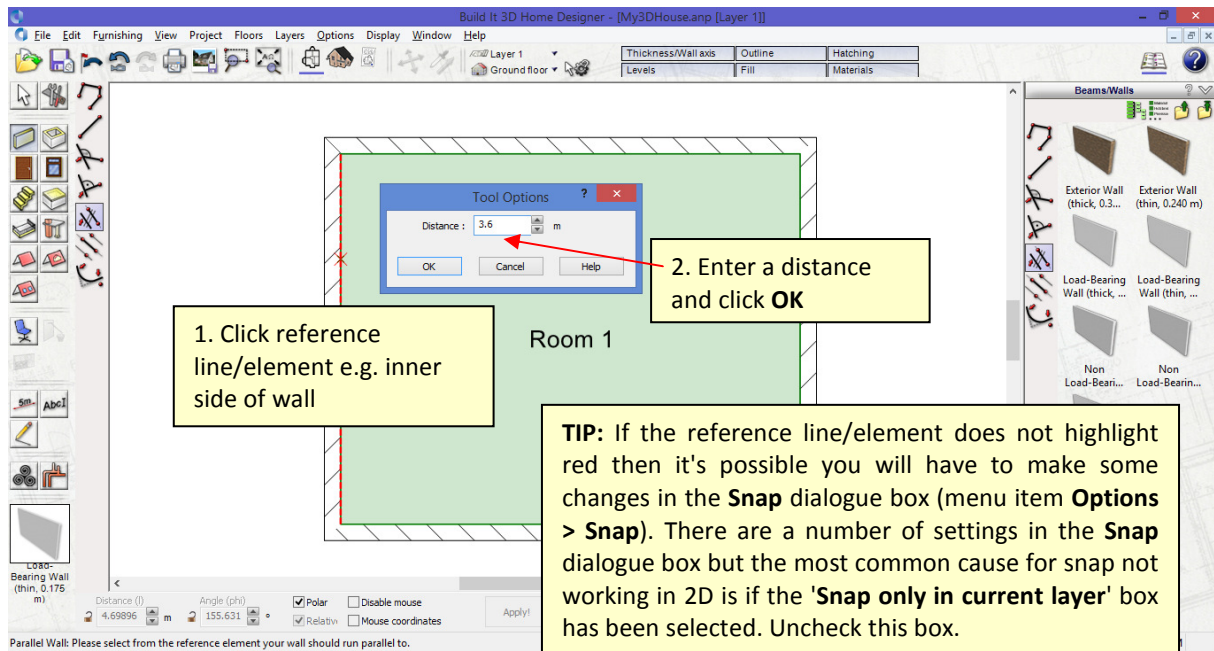

4. You now need to define what side of the reference line/element you would like the new wall to be drawn. By moving the mouse cursor either side of the reference line/element, a green guideline will appear at the desired distance you entered in previous dialogue box. In this example, left-click to place the guideline on the 'right' side of reference line/element:

3D Architect Home Designer

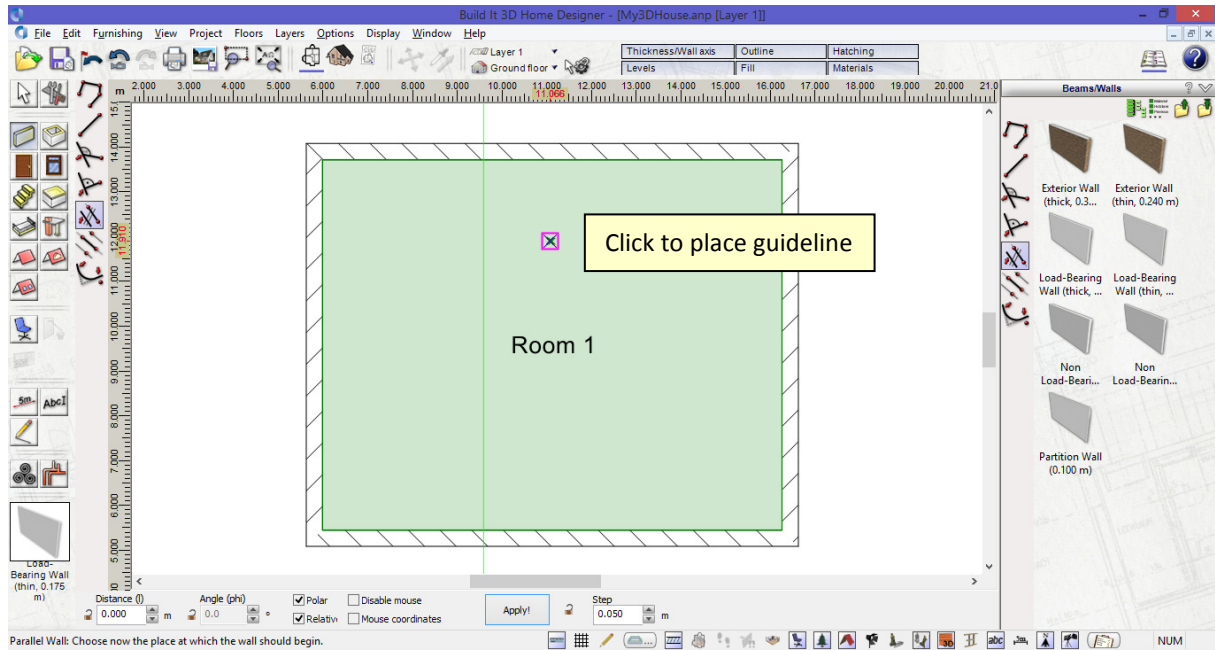

5. Before the wall can be drawn at the specified distance (to guideline) you first need to determine where along the guideline you would like the wall to start. You can click on guideline itself or to side of guideline to determine the start point. In this example, we would like the wall to start from the inside edge of top wall. Therefore, click the 'inner edge of top wall':

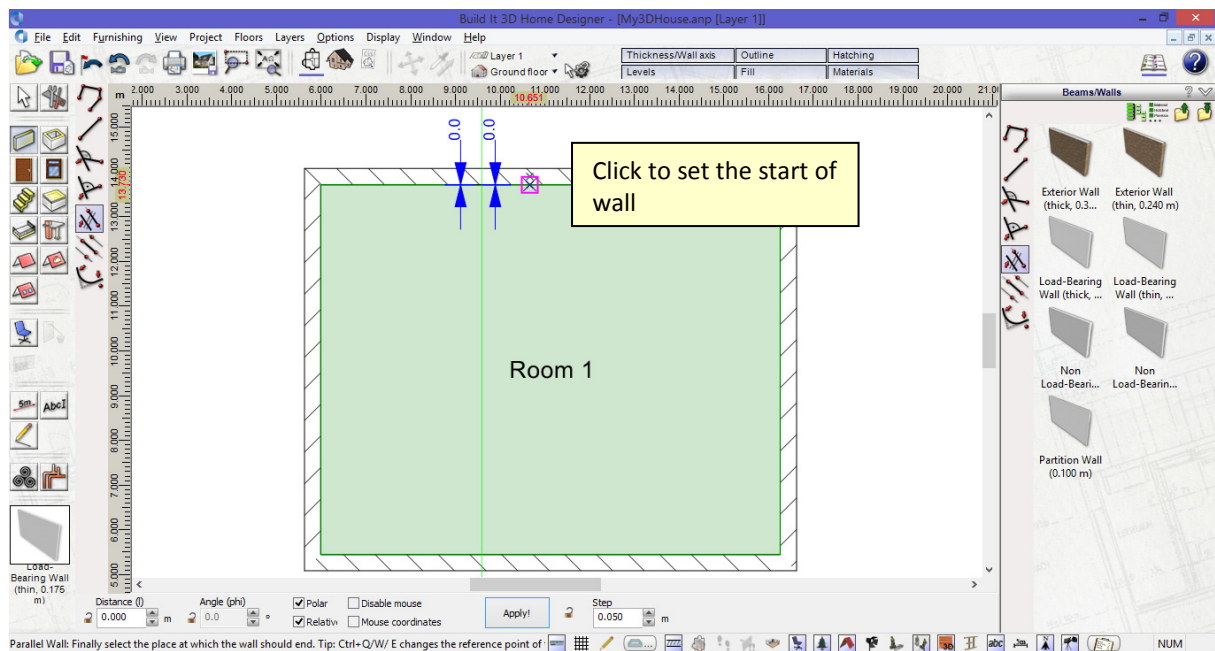

6. By moving your mouse cursor up or down you will see a ghost image of new wall together with dimensions attached to guideline. The wall direction also affects how the wall is placed along guideline e.g. drawing the wall in an upward direction will place the wall to the opposite side of guideline than if you were drawing wall in a downward direction. The drawing of walls is sometimes determined by the last key combination used for toggling between walls edges and wall axis. The following TIP box provides you with details on the **Ctrl + W** key combination for defining which wall edge to use before placing wall in position.

3D Architect Home Designer

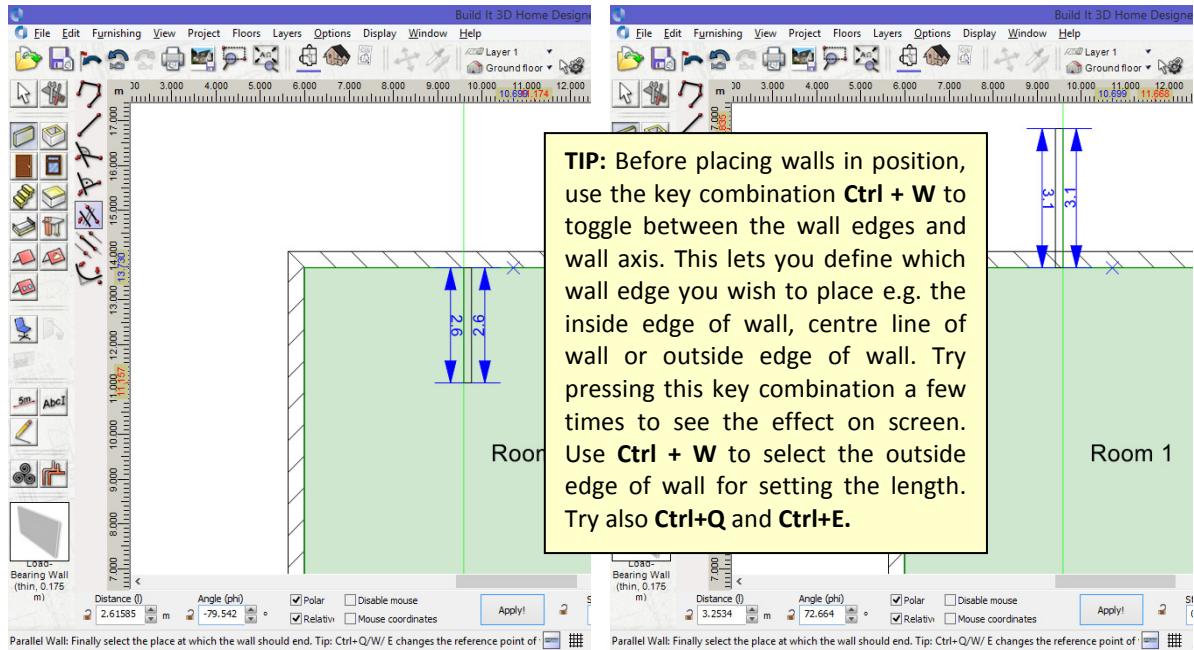

- In this next step you now need to set where you would like wall to be drawn to (wall length) using numeric input. Ensure the wall is facing in the correct direction i.e. down and with the numeric input bar enabled at the bottom of screen (menu **Display > Numeric input**), use the **Tab** key to select the **Distance (I)** field. Now overwrite the current value with **4.155m** and confirm by pressing the **Enter** key or clicking **Apply**.

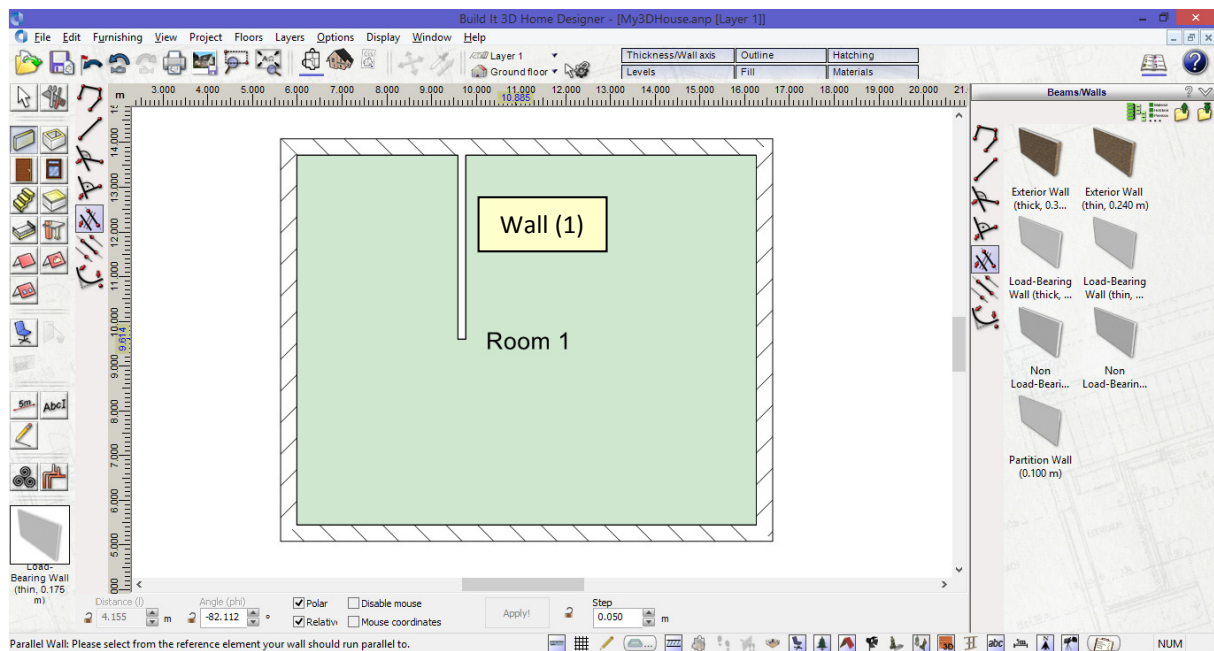

- Your first wall has now been drawn using the parallel wall input option. Using the same method, draw the next wall to start from the inside edge of bottom wall. In the **Distance (I)** field, the wall length needs to be entered as **2.9m**. Before placing wall, use the key combination **Ctrl + W** to ensure that the correct edge is being used e.g. inside edge of wall, centre line of wall or outside edge of wall. The position of the 2nd wall should look like the following:

3D Architect Home Designer

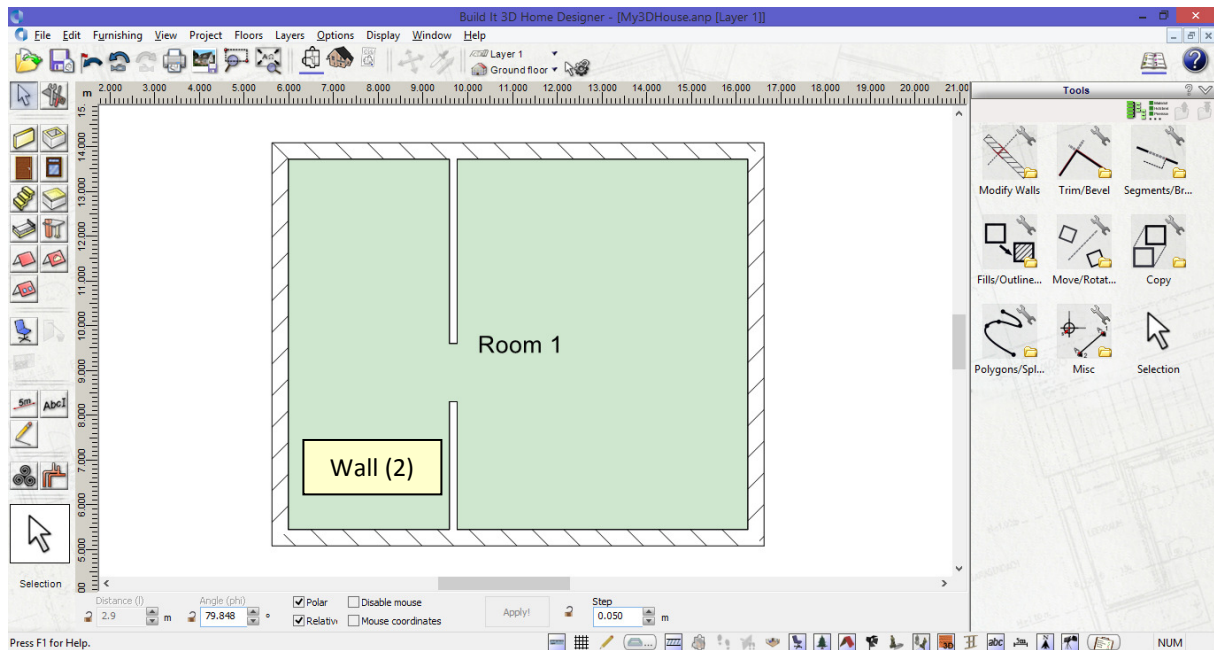

9. Now draw in a 3rd wall parallel to the wall you have just drawn (wall 2) at a distance of **3.0m**. The wall needs to be drawn to the right of the reference line/element at a length of **3.1m**:

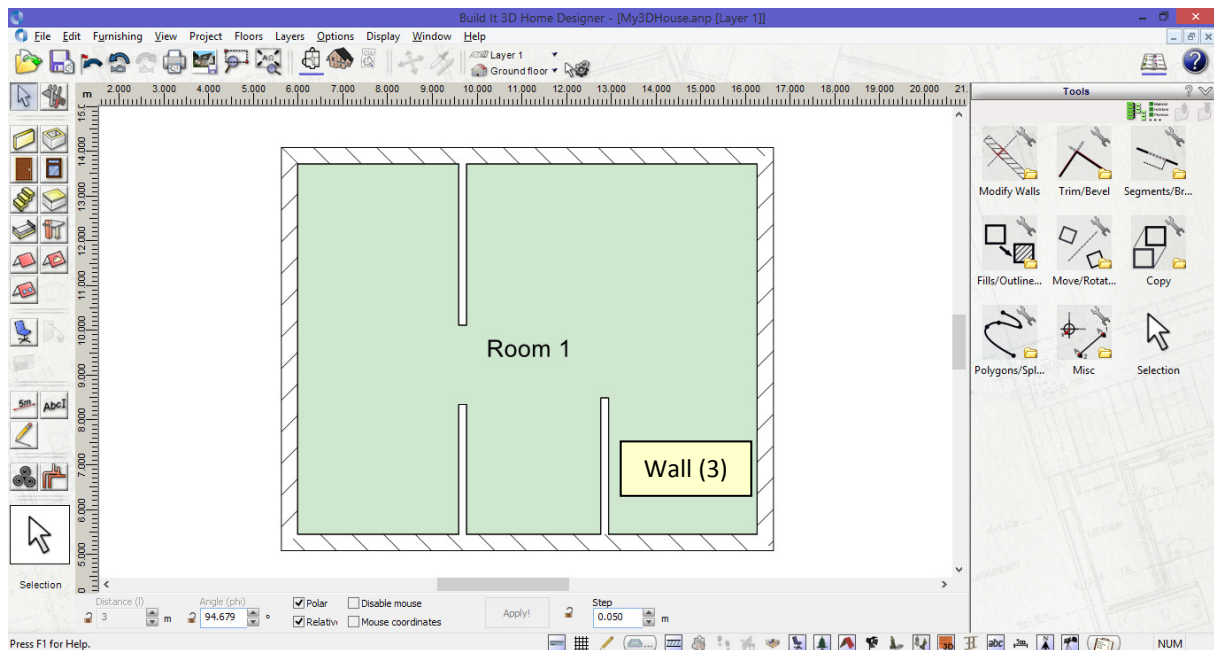

Drawing single walls

You should now have 3 vertical walls in place which have all been drawn using the parallel wall option and numeric input. We will now use the single wall option to draw in the horizontal walls.

1. In the **Wall** catalogue select the wall type **Interior wall (thin)** and select the input option **Single wall**. Move your cursor over to wall 3 and click the wall end. The wall will attach itself to existing wall and by moving your cursor to the left or right will draw a ghost image of wall together with dimensions.

3D Architect Home Designer

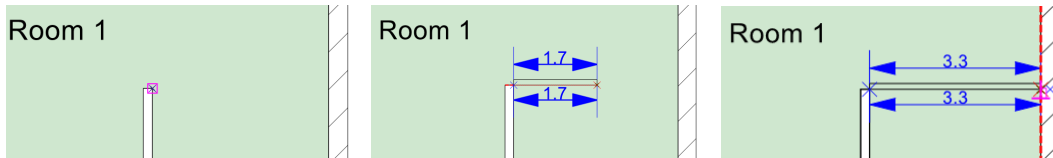

2. Drag the mouse cursor out towards the external wall on right and when it reaches and snaps to the 'inner edge of wall' (highlight in red), left-click to place wall in position.

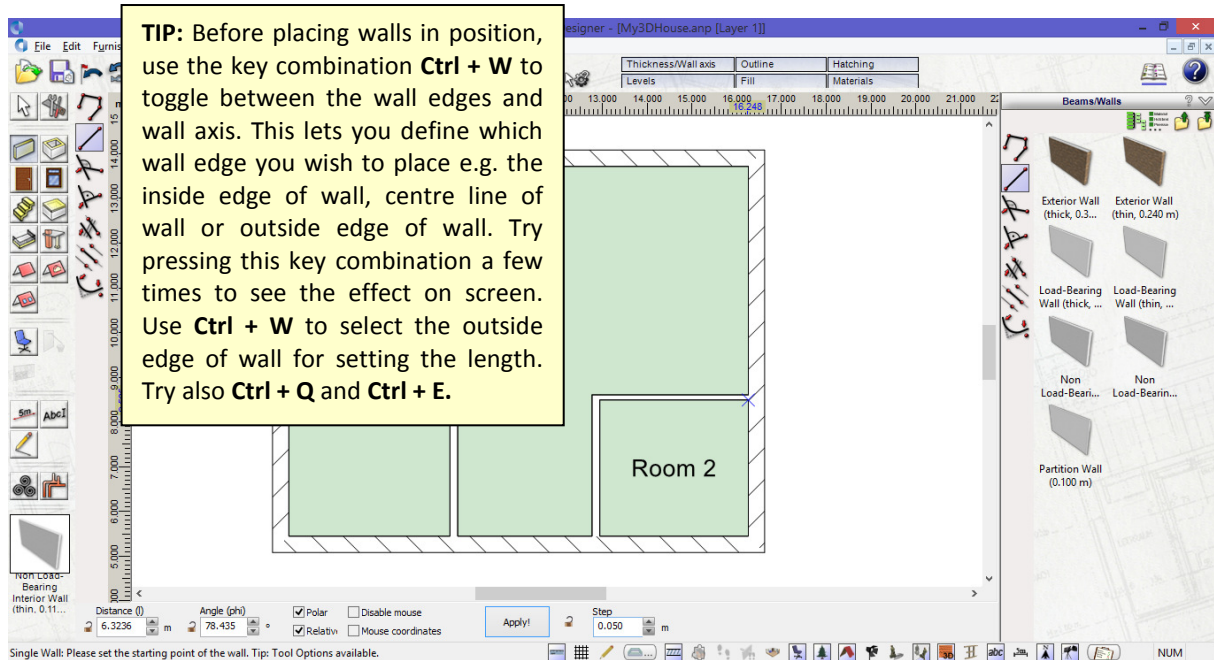

3. Continue using the single wall option to draw in the remaining walls. Your project should look like the following:

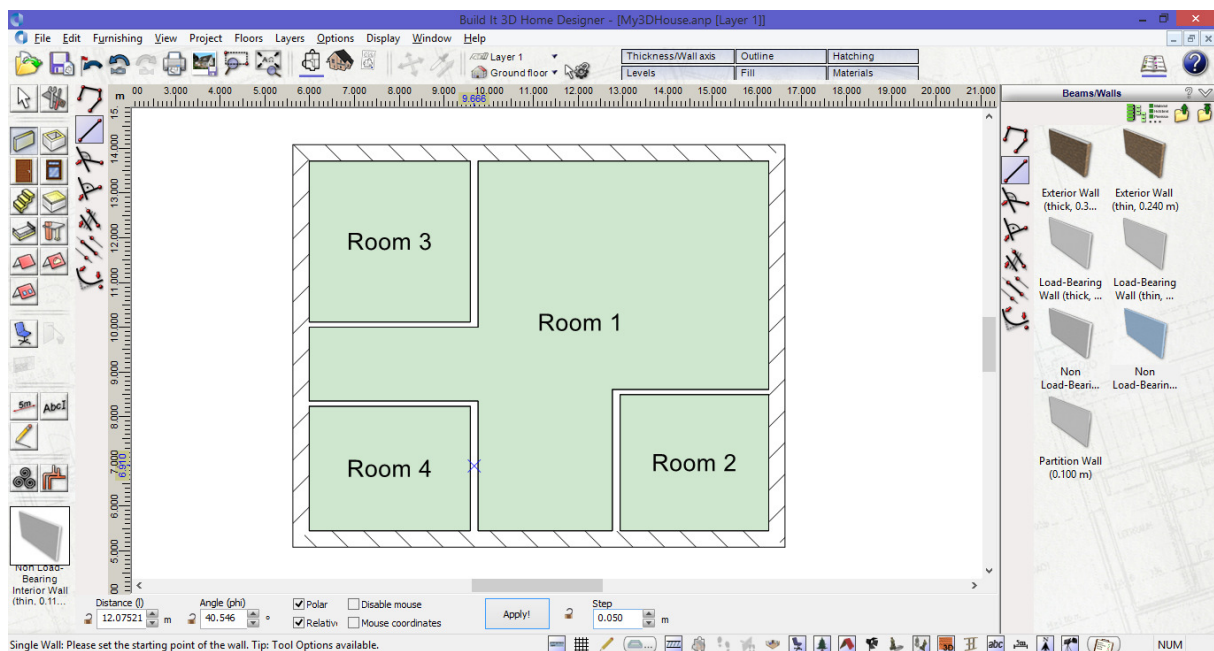

Drawing walls at fixed angle

In this section we will now draw a wall at a fixed angle of 45° from Room 2.

1. In the **Wall** catalogue select the wall type **Interior wall (thin)** and select the input option **Angled wall**.

2.  Click the **Tool Options** icon in horizontal toolbar and in the dialogue box that appears enter **45°** in to field.

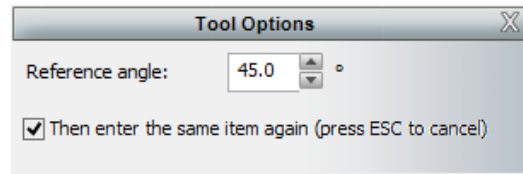

3. Move your cursor over towards Room 2 and click reference wall. Your wall will be created at the selected angle to this wall.

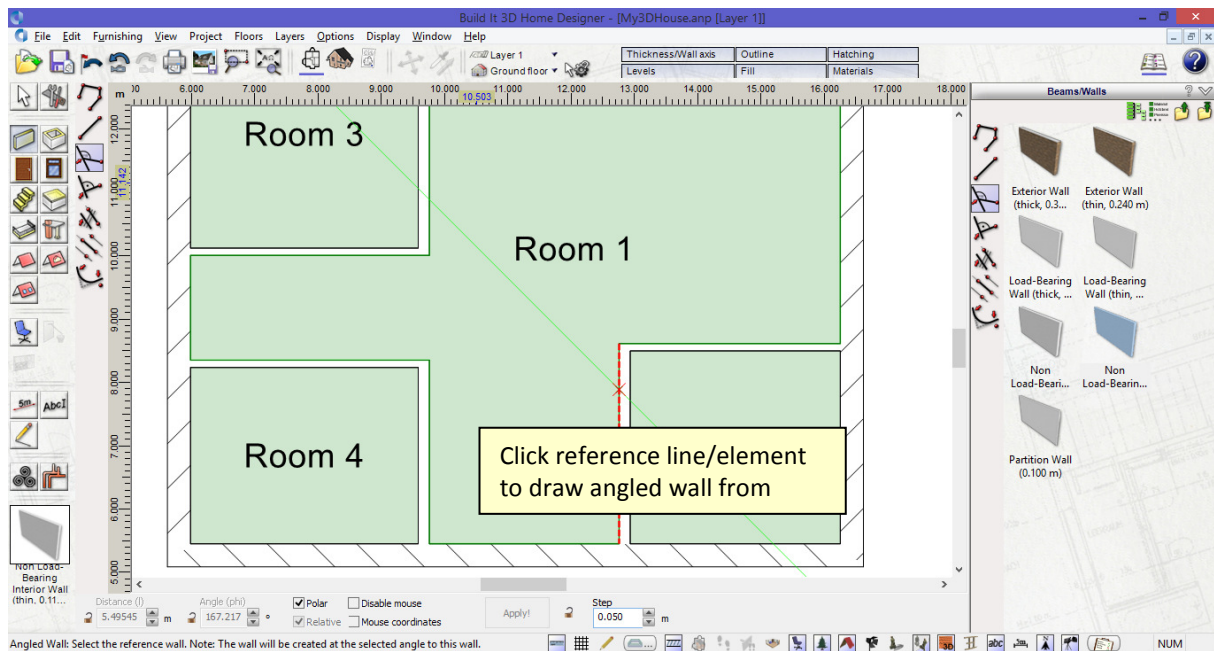

4. Now click to specify the starting point of wall.

3D Architect Home Designer

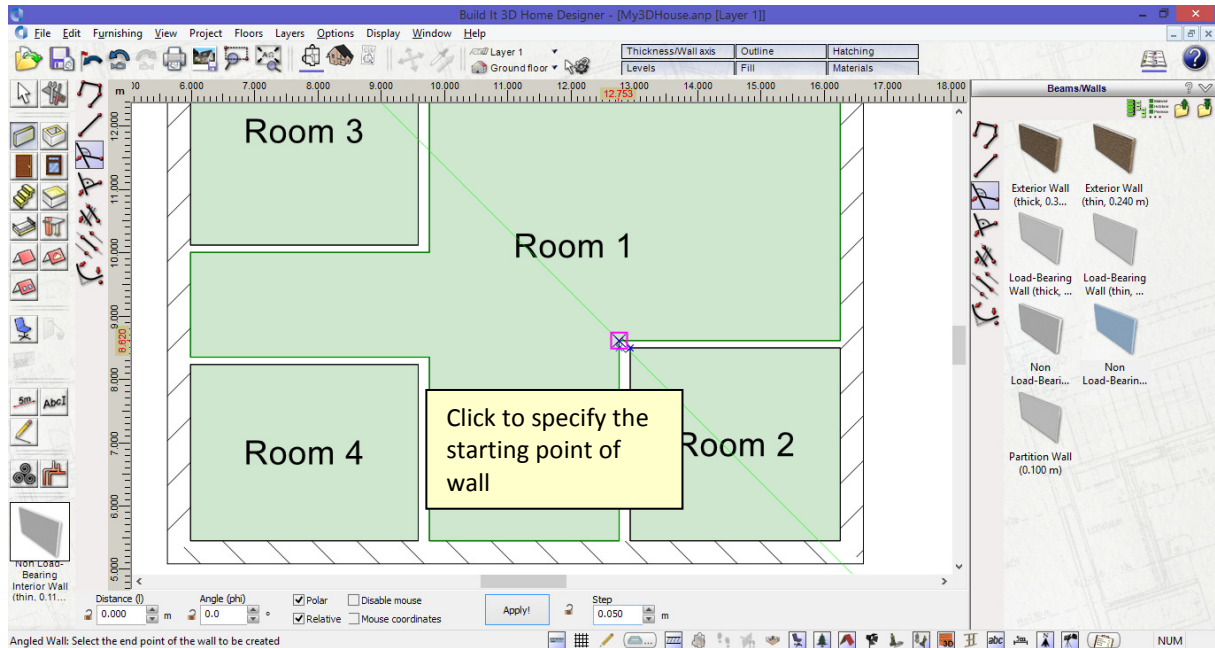

5. You now need to specify the end point of wall. Having specified start point, the wall will attach itself to existing wall and by moving your cursor to the left or right will draw a ghost image of wall together with dimensions attached to guideline.

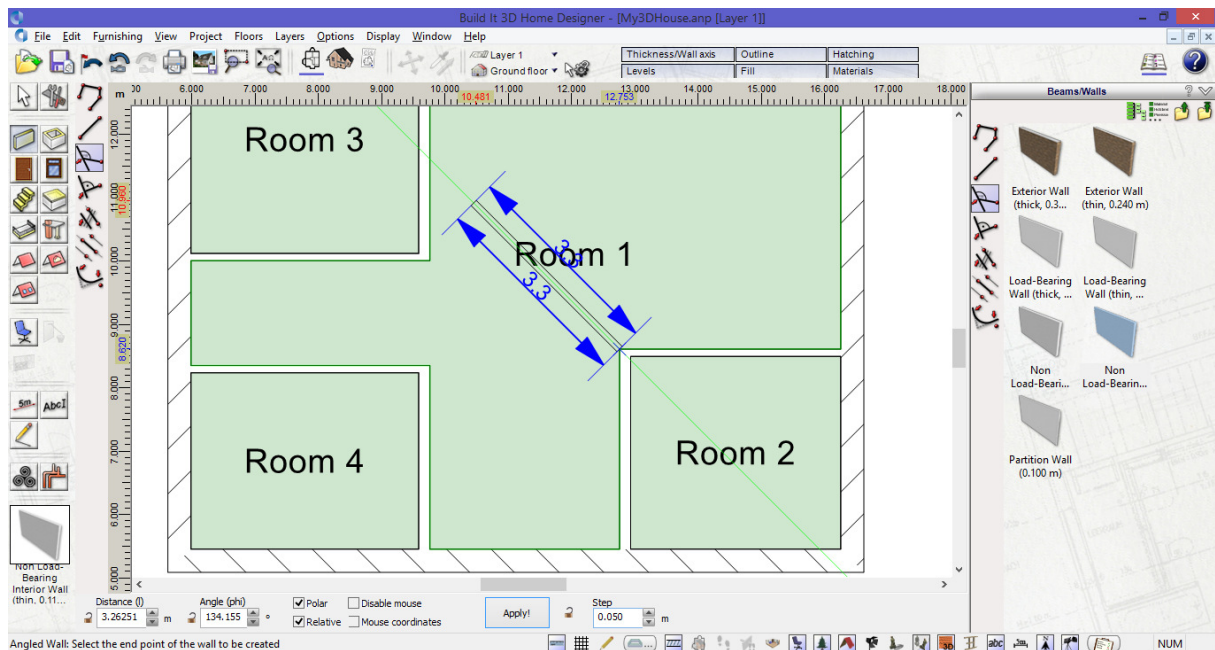

6. Before placing the wall in position, use the key combination **Ctrl + W** to toggle between the wall edges and wall axis. This lets you define which wall edge you wish to place e.g. the inside edge of wall, centre line of wall or outside edge of wall. In this example place the wall centrally to guideline and left-click to set the end point of wall:

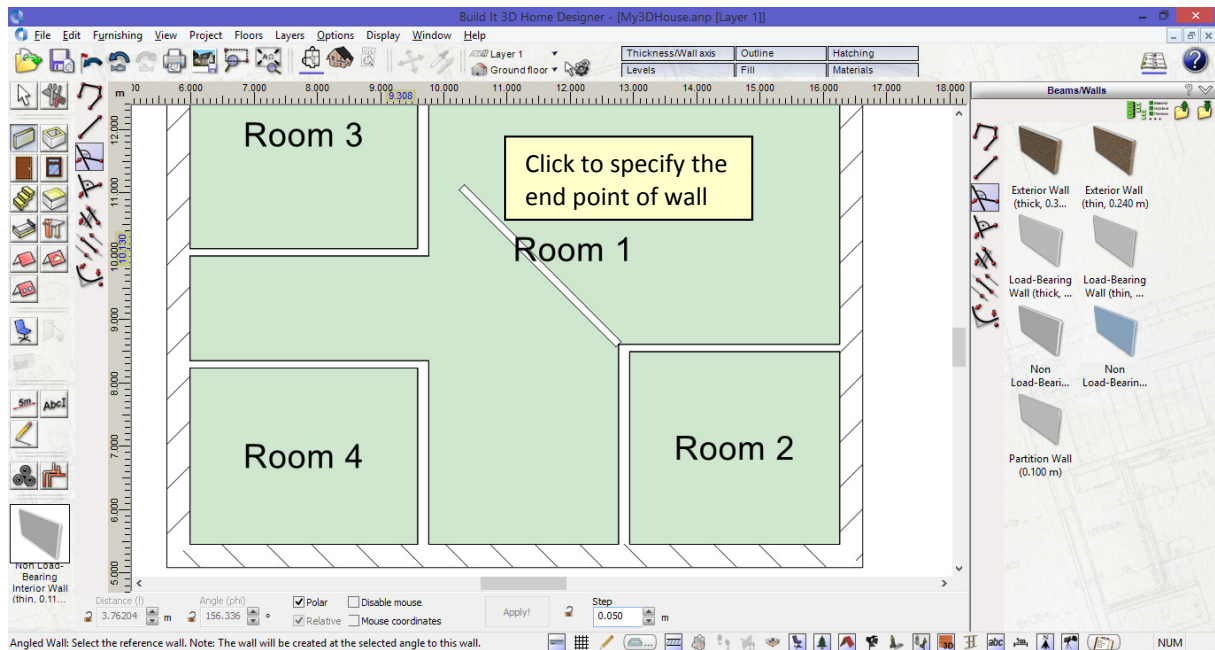

Editing tools: Mitre walls (L) option



In the previous section you learnt how to draw an angled wall from an existing wall but notice how the walls do not join correctly!

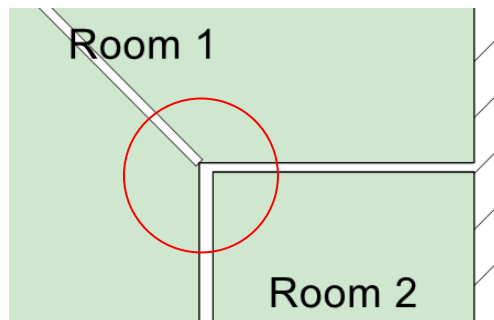

In this section you will learn how to mitre walls together using the editing tools provided.

1. There are number of editing tools available to you for modifying parts of drawing. Left-click the **Editing tools** icon in the vertical bar on the left and a fly-out menu will appear with some preset tools.

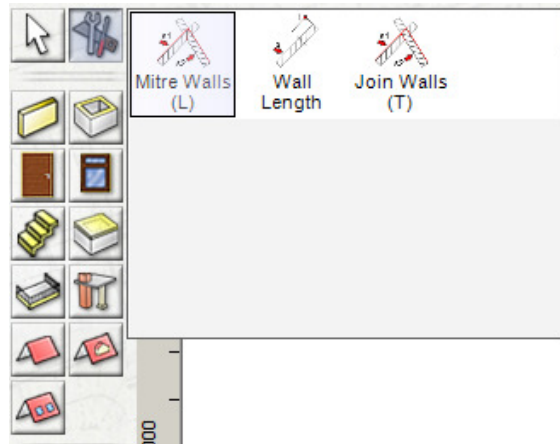

2. From the fly-out menu select the tool **Mitre walls (L)**. Alternatively, select this from the **Modifying walls** folder in the **Tools** catalogue.
3. With the **Mitre walls (L)** tool selected, left-click the 'horizontal wall' in Room 2 followed by the 'angled wall':

TIP: After left-clicking the **Editing tools** icon in the left vertical bar, an extensive selection of tools are made available in the catalogue bar on the right-hand side of screen under the catalogue name **Tools**.

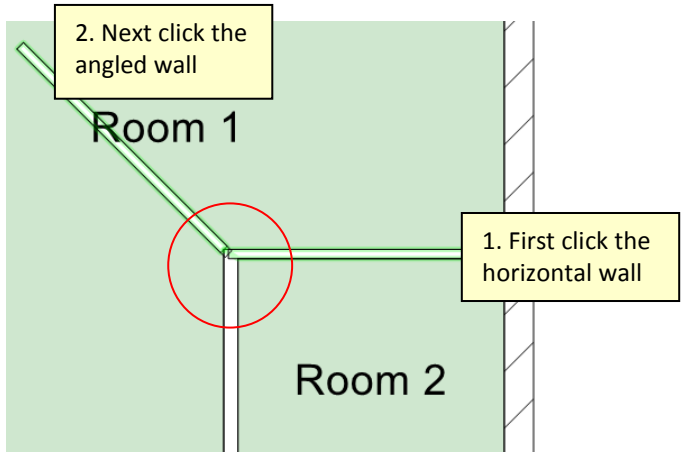

The two walls will mitre together.

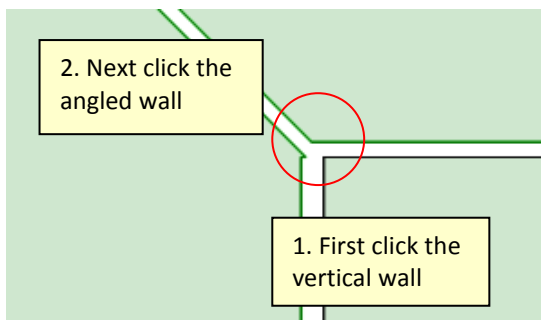

4. Now repeat this method in Room 2 by first selecting the 'vertical wall' followed by the 'angled wall' to get the following result. All 3 walls will now be mitred together:

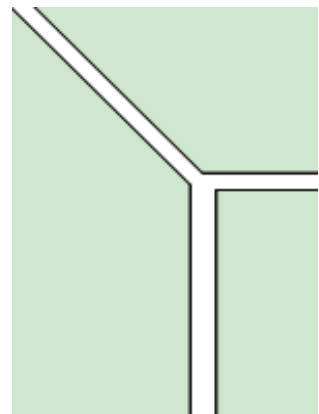

TIP: Note it is not always necessary to use this mitre tool for joining corner walls together. Depending on position of wall start/end point, the software will often determine the mitre joints automatically.

5. Locate Room 3. We are now going to use the same tool and method to mitre together the 'angled wall' and the 'horizontal wall'. The two walls will trim to the correct length so that the corner ends mitre together.
6. With the **Mitre walls (L)** tool selected, left-click the 'horizontal wall' in Room 3 followed by the 'angled wall':

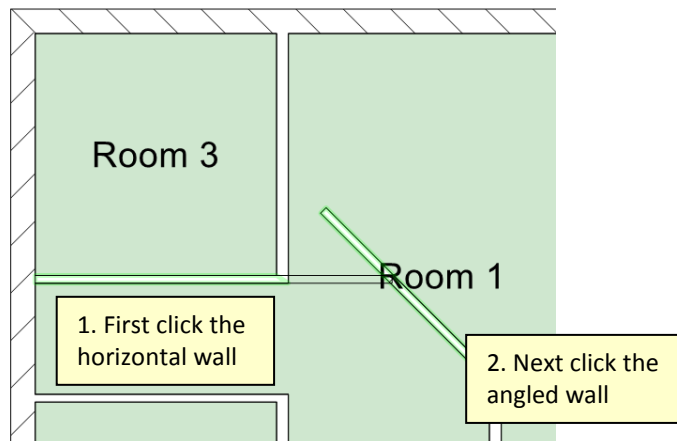

The two walls will mitre together giving you the following result:

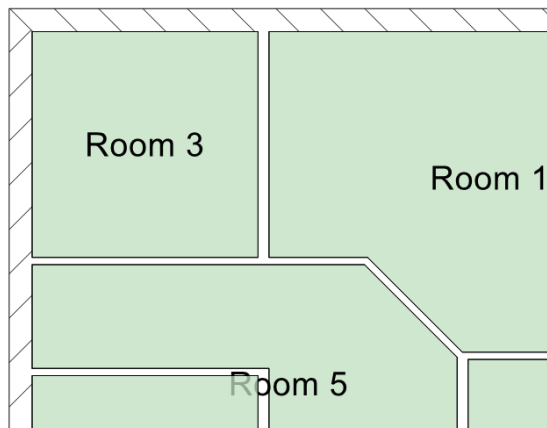



Placing guidelines

There are several methods to plan out a building. In the previous section we demonstrated using numeric input and other placement options for walls. Another easy and accurate method is to use guidelines to plan out your building, even before placing the first wall. These can be used also for pegging out your plot or for accurately inserting other elements in to your plan.

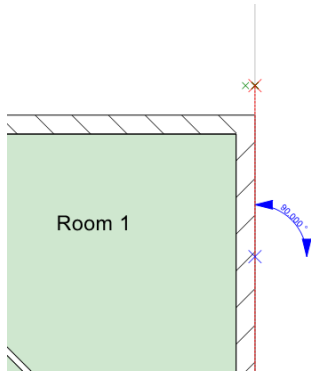
There are a number of guideline options but one of most useful ones is **Parallel to reference line (guideline)** for spacing your guidelines at exact distances. Practice using this somewhere in your plan by following the example steps below:



1.  Select the **Guideline** tool from the icon bar. From the **Guidelines** catalogue window select the first option **Arbitrary line (guideline)**.
2. Place a single guideline to use as an origin/start point by left-clicking followed by a second click to set guideline in position.
3. In **Guidelines** catalogue select the guideline option **Parallel to reference line (guideline)** 
4. With this selected, click on the origin guideline to display the following **Tool options** dialogue box.
5. Here you can enter the offset distance e.g. 3.00 m

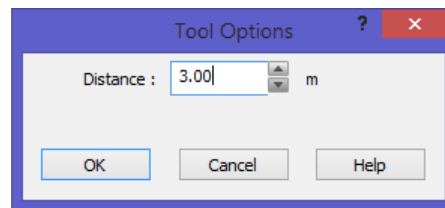

6. Move the mouse pointer either side of origin guideline where you want the guideline placed (highlighted green) and then left-click to place guideline in position.

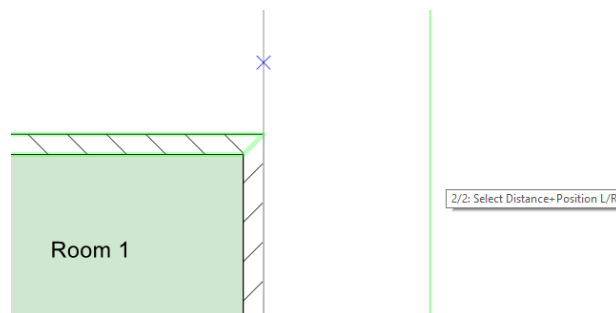

7. You will now have two guidelines in place with an exact distance of e.g. 3.00 m between them. With these in place you can accurately draw in a wall for example by using one guideline as start point of wall and then the other as end point of e.g. below.

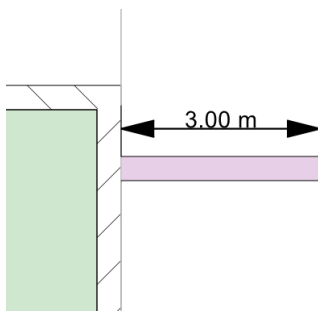

TIP: If the reference line/element does not highlight red then it's possible you will have to make some changes in the **Snap** dialogue box (menu item **Options > Snap**). There are a number of settings in the **Snap** dialogue box but the most common cause for snap not working in 2D is if the '**Snap only in current layer**' box has been selected. Uncheck this box.

Window and door placement

In this next section you will learn how to insert windows and doors into walls at a set distance in your plan. There is a large selection of window and door types available in software. These can all be modified separately and inserted into wall using different input methods.

Windows

1. Start by left-clicking the **Windows** icon in the vertical bar on the left.

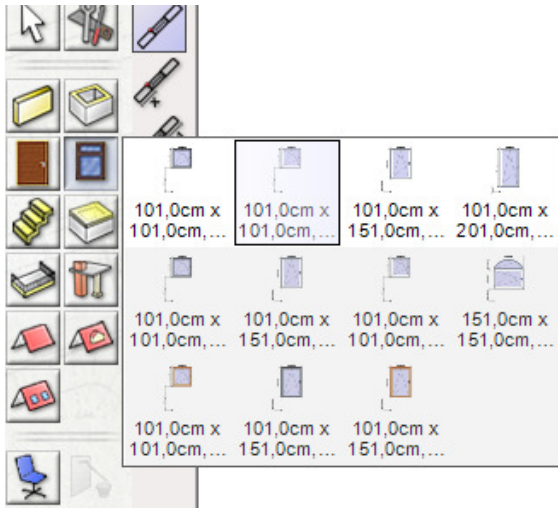

TIP: After left-clicking the **Windows** icon in the left vertical bar, an extensive selection of windows are made available in the catalogue bar on the right-hand side of screen under the name **Windows/Cut-outs**.

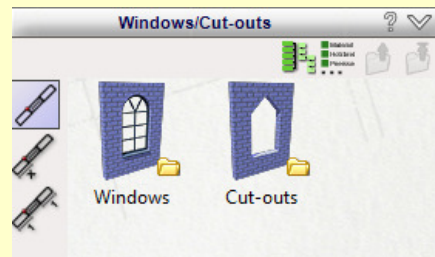

2. From the fly-out menu select a window type. Alternatively, select one from the folder **Windows > Rectangular windows** in the **Windows/Cut-outs** catalogue.
3. On selection of window type a **'Component'** button will appear in the horizontal bar at top. Clicking this will enable you to make various changes to selected component.



4. After clicking the **'Component'** button, the following **Component** dialogue box will appear:

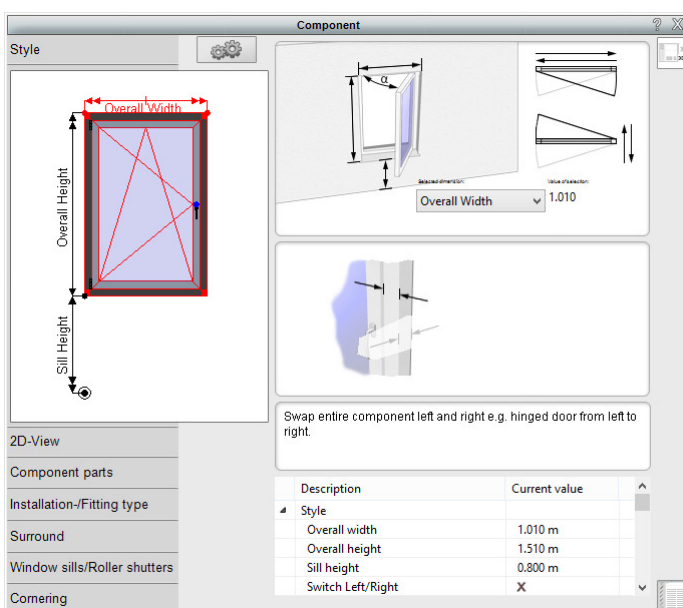

TIP: The dialogue box can be left open if you want to select and preview another window type from catalogue. The preview and properties of selected window will update accordingly in dialogue box. The dialogue box can be left open for making further changes and closed by clicking the cross in the top right. All window settings will be retained in dialogue box for future access.

- The **Component** dialogue box consists of different tabs that enable you to make various adjustments to all aspects of component via the use of interactive graphics and/or list view. By clicking on parts of graphic, you are able to make changes to component quickly and easily. The corresponding values in detailed list view will update accordingly. You can toggle between a graphical display and full list view using the icon in the bottom-right of dialogue box:

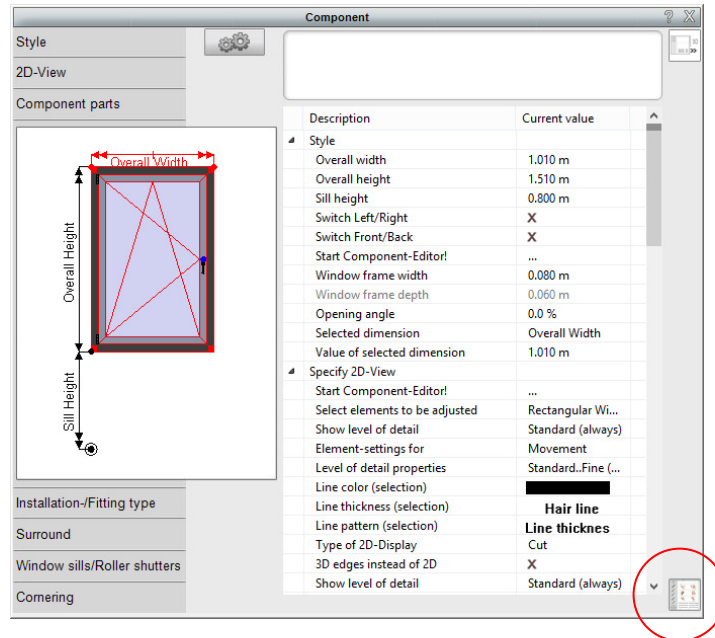

- We will now adjust some basic shape properties of component which include the width, height and sill height of window. Under the **Style** section, locate the following graphic:
- Left-click on the horizontal arrow (highlighted red) and in the **Overall width** input box that appears enter the following value:

Overall width: 1.010m



Repeat and click the other arrows on graphic entering the following values:

Overall height: 1.510m
Sill height: 0.800m

- To accurately insert a window at a specified distance from reference point, select the input method **Window at set distance** (in *How bar*) from within the catalogue or from the left-side of screen.
- Click the **Tool Options** icon in the horizontal bar and in the dialogue box that appears enter an offset value of **1.4m** and select **Left edge**. The offset value will set the distance from the reference point to the left edge, right edge or centre point of window/door.



TIP: Guidelines can also be used to help position windows and doors at a set distance. See Guidelines section.



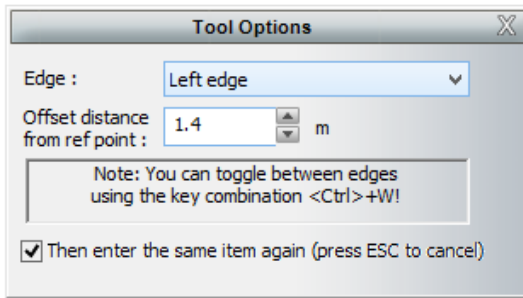

TIP: Setting the distance to the 'left' or 'right' edge of window/door is always determined by the direction in which the walls have been drawn and the corresponding view. You can toggle edges using the key combination **Ctrl + W**.

After setting all parameters you can now insert the window in the following way.

10. Specify the reference point by clicking on wall:

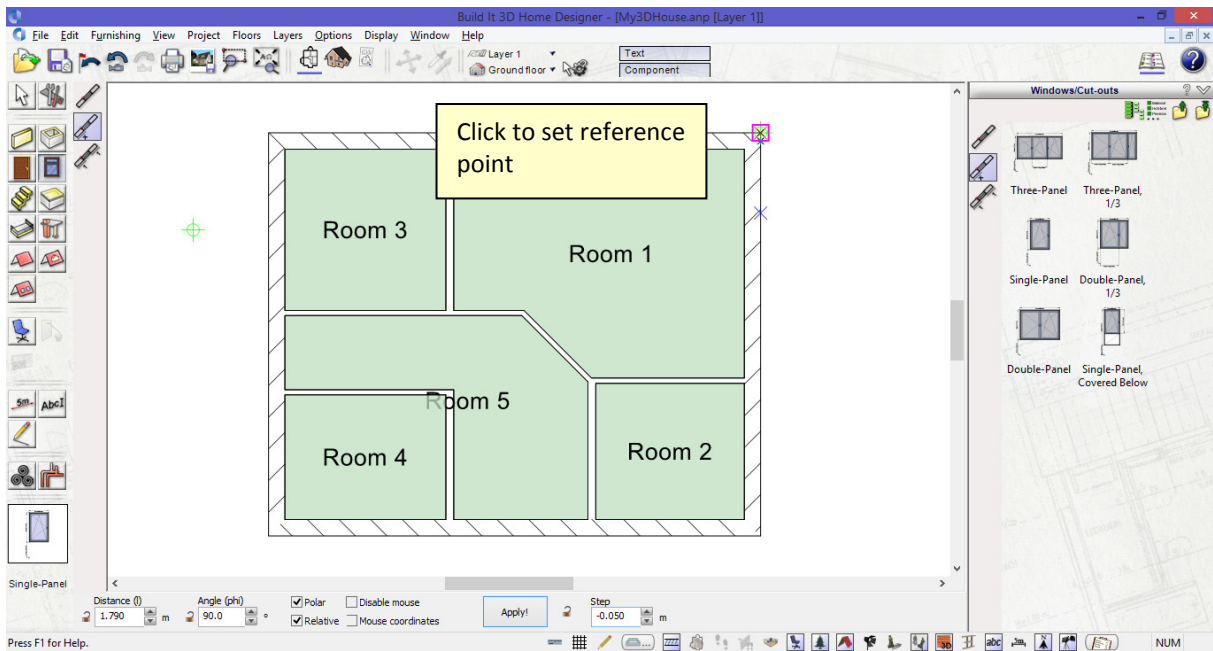

11. Now select and click the wall where you would like the window to be inserted.

12. Before the 3rd and final click, move the cursor around window to determine the stop and direction of window opening. Click to insert window in position.

13. The window (a) is now in position at an offset distance of **1.4m** from reference point as specified in the **Tool Options** dialogue box.

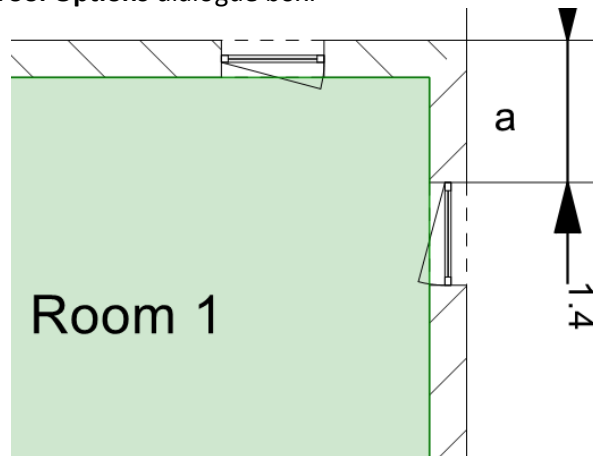

12. Continue inserting the remaining windows (b, c, d, e, f, g) using the same input method and offset distance.
13. On the top external wall, in Room 1, insert a window (h) from the top-right corner at a distance of **5.0m** and on the other side, in Room 3, insert a window (i) from the top-left corner at a distance of **2.4m**.

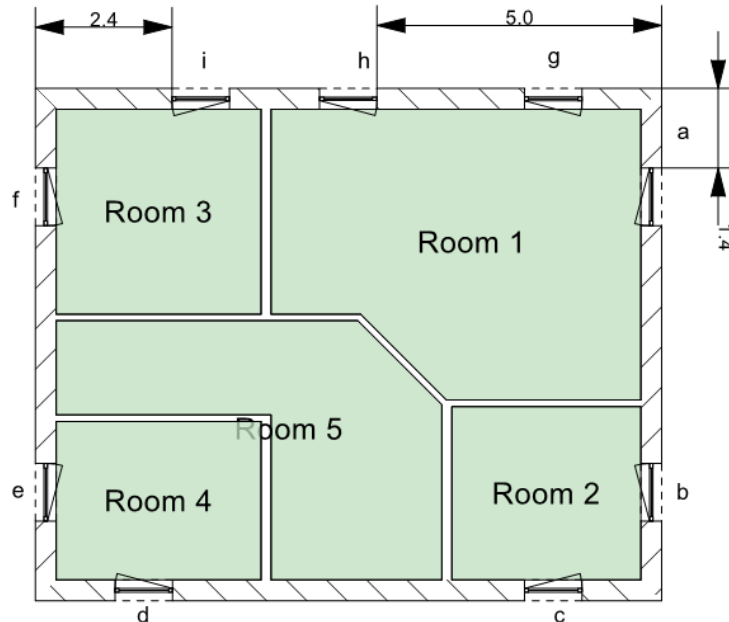

Doors

You insert doors in the same way as windows using the three input methods **Door free positioning**, **Door at set distance** or **Door midway**.

1. Let's start by left-clicking the **Doors** icon in the vertical bar on the left. In the **Doors** catalogue that appears, select a standard entrance door.
2. Now select the input method **Door at set distance** and click the **Tool Options** icon in the horizontal bar and in the dialogue box that appears enter an offset value of **0.5m** and select **Left edge**. The offset value will set the distance from the reference point to the left edge, right edge or centre point of window/door. Insert the door into front wall from the inside wall of room 2. See below:

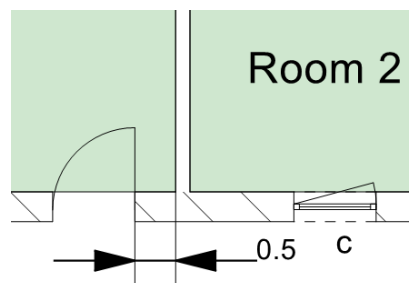

3. For Room1, select a standard internal door from catalogue and insert door using the input method **Door Midway**. In the first two steps you define the two reference points along the wall you would like the door to be inserted midway. In the third step click the wall where you would like the door to be inserted and in the fourth and final step, move the cursor around door to determine the stop and direction of door opening. Click to insert door in position as follows:



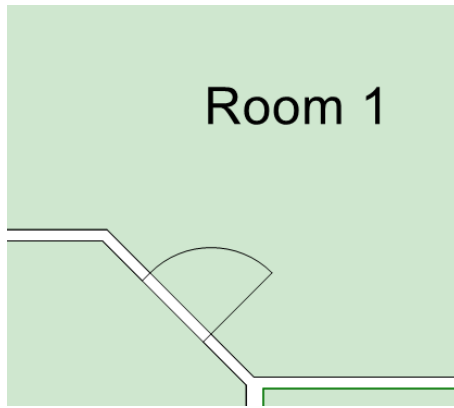

4. For the remaining internal doors, use the input method **Door free positioning**. Move the door along the desired wall and once you have determined its position, left-click. In the next step, move the cursor around door to determine the stop and direction of door opening. Click to insert door in position as follows:

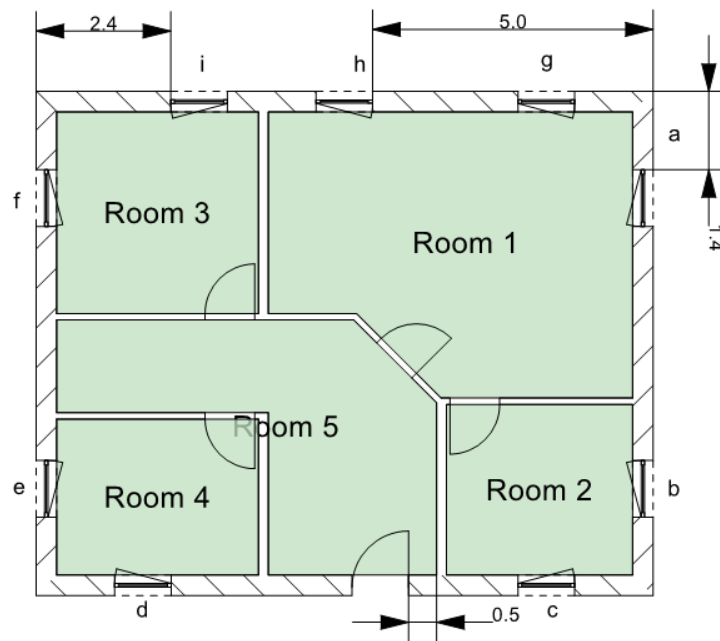

5. To view the current plan in 3D, click the **3D Furnishing Mode** icon in top horizontal toolbar.



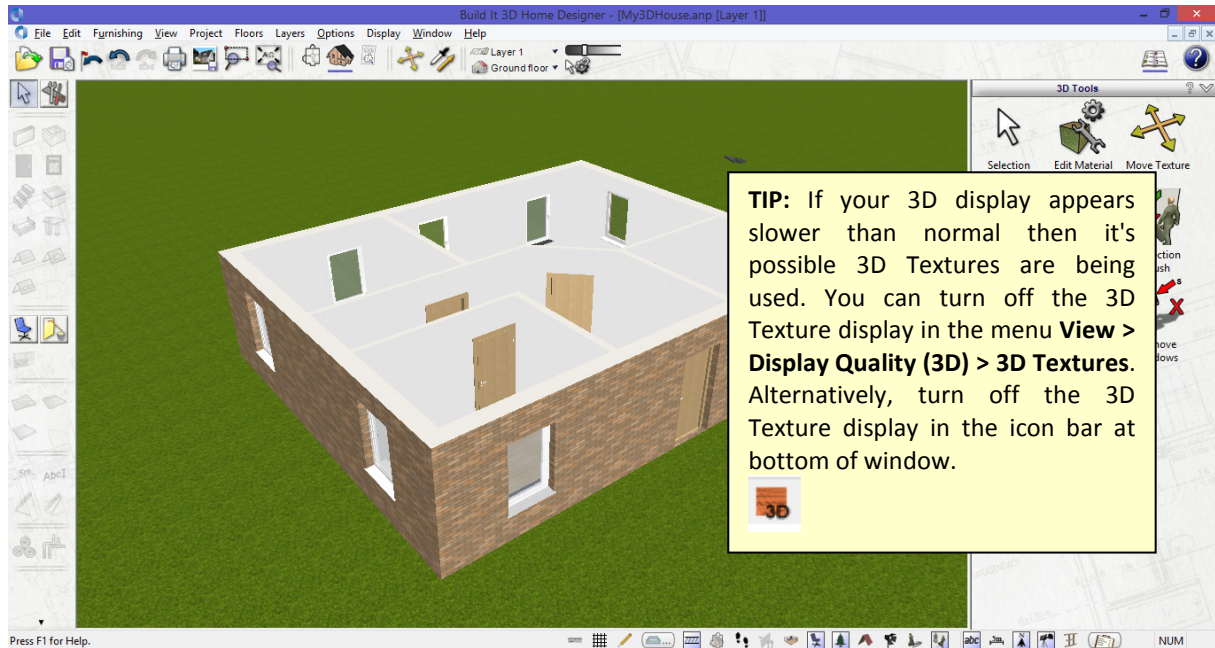

6. To go back to your plan, click the **Construction Mode** icon

Assigning room names

By default, room names are generated automatically labeled  Room 1, 2, 3 etc. These can be easily changed to more meaningful names that are relevant to your project.

1. In Construction mode, left-click inside one of the rooms and in the horizontal toolbar, select the tab for **Room Data**. A dialogue box will open where you can change the room name and add further detail such as room description, area etc.

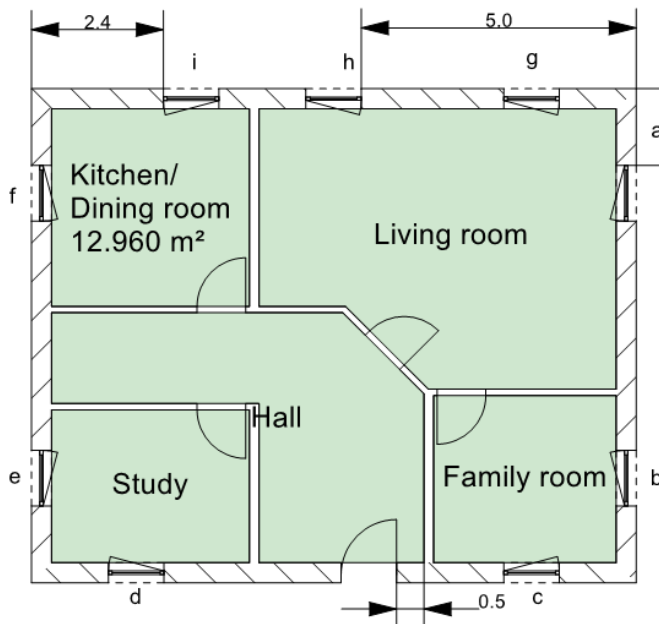

TIP: After left-clicking the **Stairs** icon in the left vertical bar, an extensive selection of stairs are made available in the catalogue bar on the right-hand side of screen under the name **Stairs**.

Adding staircase to your plan 

There is a large selection of stair types available in software but in this next section you will learn how to insert an L-shaped stair in to your plan.

Stairs 

1. Start by left-clicking the **Stairs** icon in the vertical bar on the left.

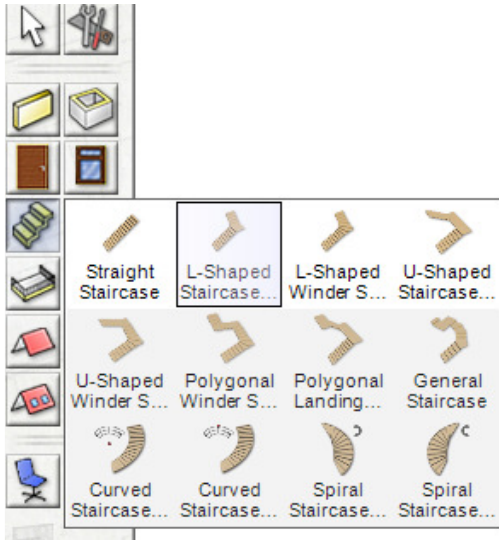

2. From the fly-out menu select the stair type **L-Shaped Staircase**. Alternatively, select this from the **Stairs** catalogue.
3. The staircase is placed with a series of 3 clicks. The first point sets the starting point of staircase, the second sets the direction and length of staircase from the starting point and the third sets the width of staircase from starting point. By default, the staircase is constructed from base level-up but in this example we will construct staircase from top-down.
4. With the **L-Shaped Staircase** selected, click the **Tool Options** icon in horizontal toolbar and in the dialogue box that appears select the checkbox option **Enter top-down**. 

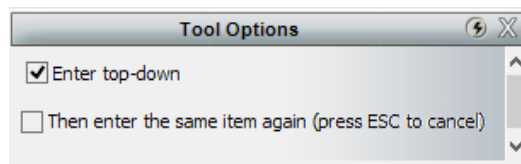

Now you can place the staircase in the following way:

5. Set the start point of staircase by clicking stair point 1 as follows:

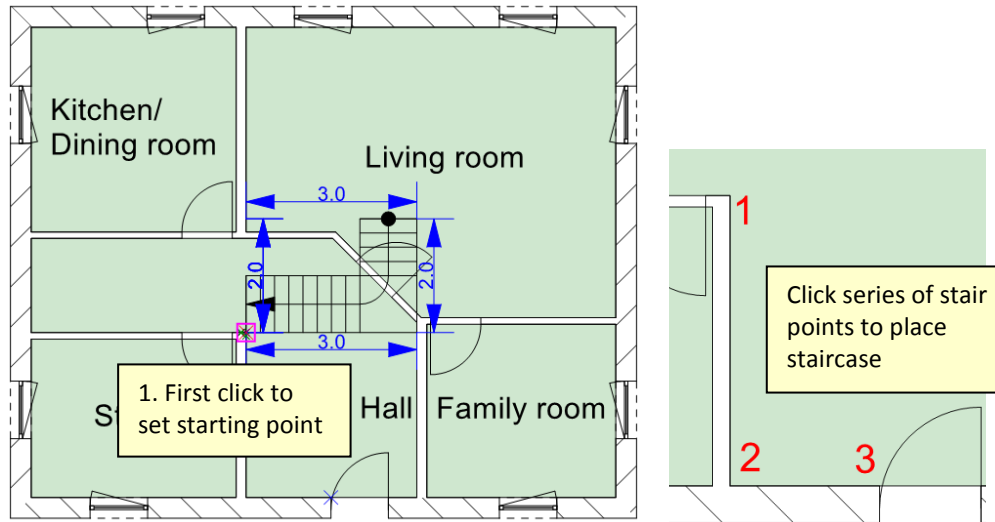

6. Next set the direction and length of staircase by clicking stair point 2:

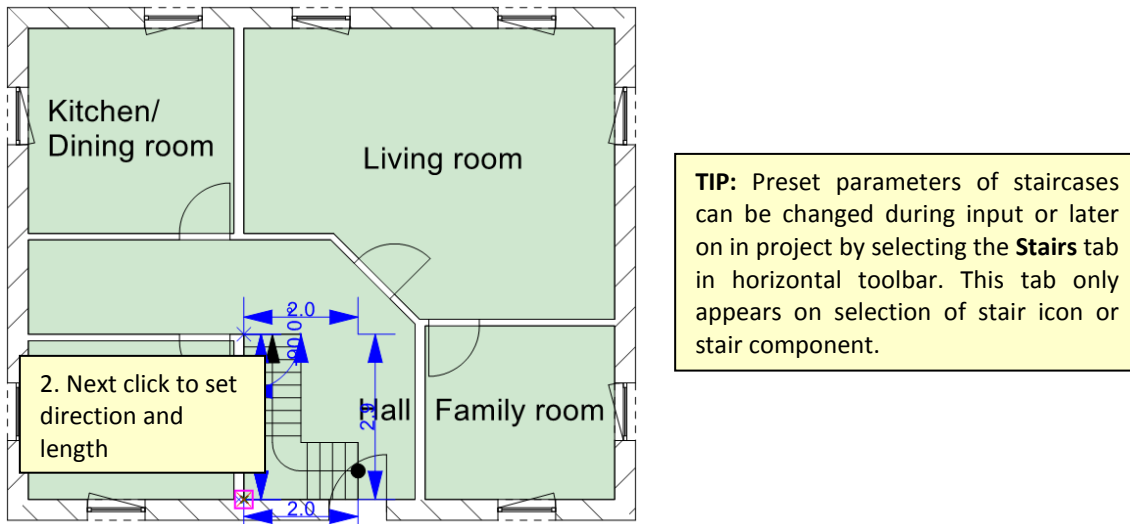

7. Next set the width of staircase by clicking stair point 3.

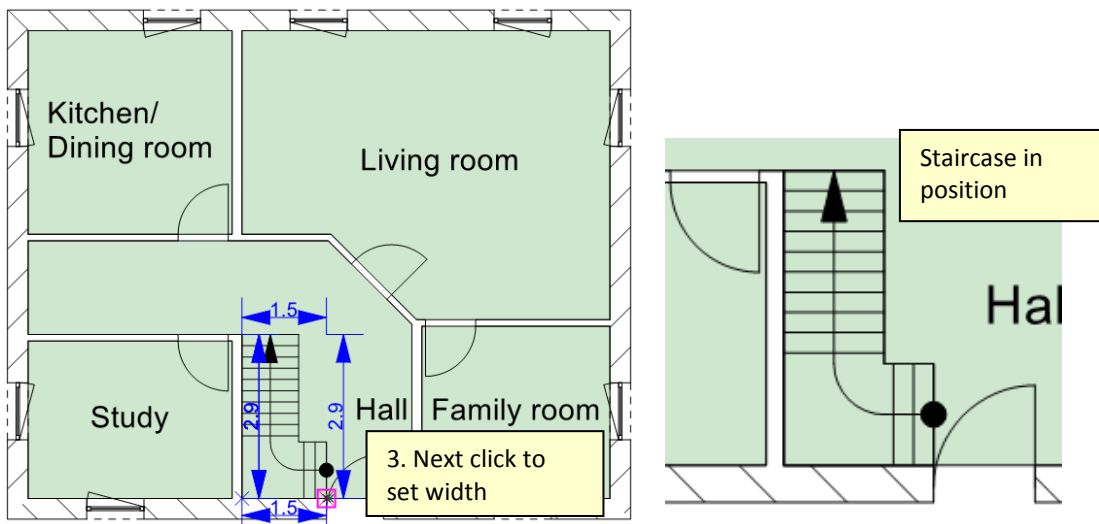

At this stage in project your ground floor should like the following:

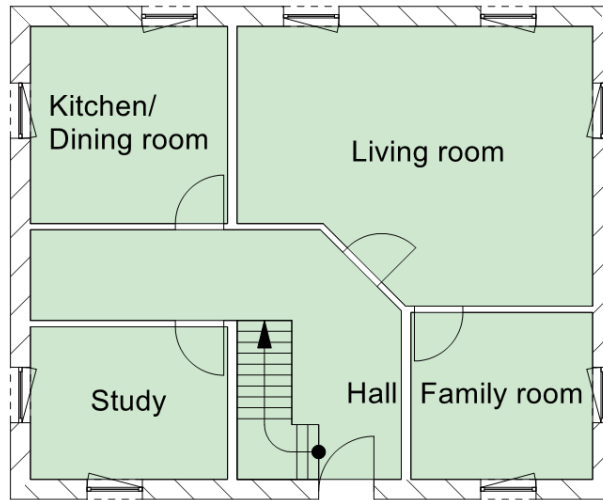

Creating additional floors

With the ground floor plan created, we can now construct extra floors. Before we add a new floor let's first look at the current floor properties.

1. Locate the menu **Floors > Edit Active Floor...** In the dialogue box that appears, various properties of current floor can be changed either before or after you create a new floor. There are different tabs for naming floors, changing height settings and assigning different materials (which can also be carried out in 3D mode).

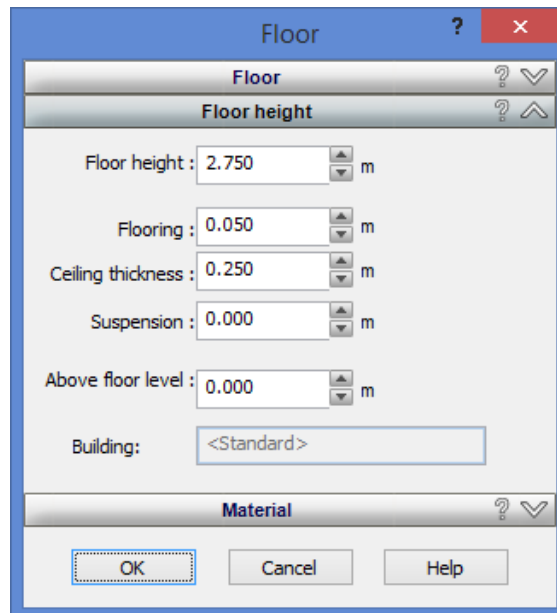

2. In this exercise, keep the current properties same and click **OK**.

Currently, your project consists of a single ground floor. If you are working with multiple floors, the preset floor levels of the various floors are determined in such a way that all floors merge into one another seamlessly.

In this exercise we want to create a bungalow home that consists of a ground floor and a top floor with walls for roof to sit on. If you were to place a roof directly on to current ground floor, visually this might look correct however, if you were to change appearance of roof e.g. change roof side to gable end, then the gable walls will not be present. The roof is still treated as the top floor of house and therefore you need to assign this to roof as described ne next steps below. When working with floors, it's important that you understand how they behave in project in particular when constructing floor for roof.

Creating top floor for roof

1. Locate the menu **Floors > New Upper Floor...** The following dialogue box will appear but includes an additional tab for copying across walls and associated elements to new floor.

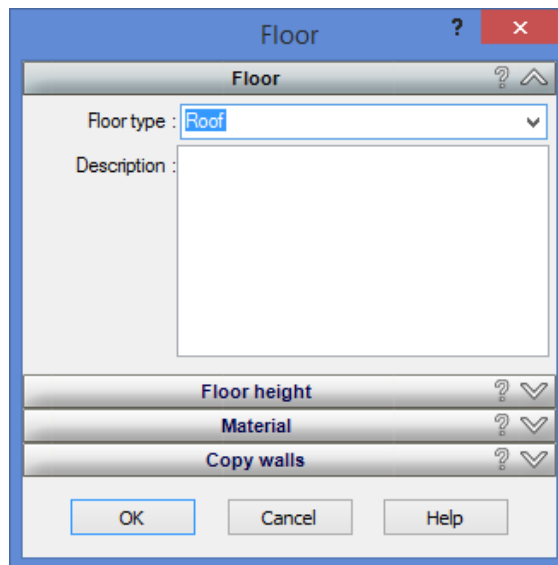

2. Click the **Floor** tab. Select **Roof** from drop down list.
3. Click **Floor height** tab. Change **Floor height** value to **6m**. Changing this value will ensure that the gable wall height extends to below the roof line. You can change this value at any time in project if for example the gable wall height needs to be extended further. The roof construction also determines the wall height so whatever value you enter, the wall will not go beyond roof line. See examples below.

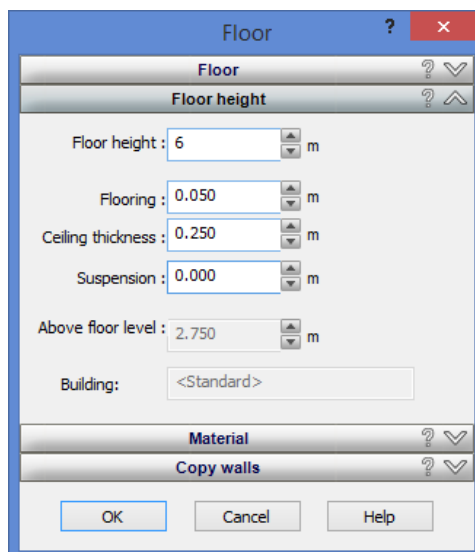

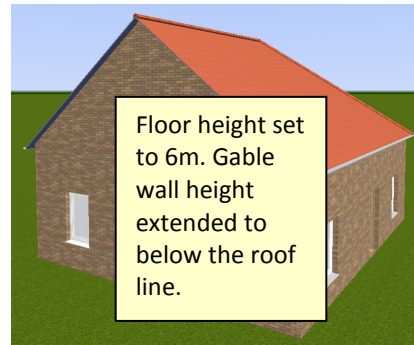
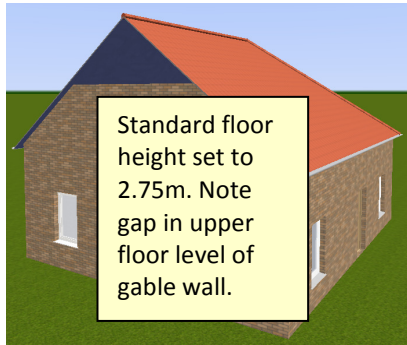

4. Click the tab for **Copy walls**. When creating a new floor you have control as to what construction elements you want to transfer over from current floor including walls (external and internal) and associated elements i.e. windows, doors, openings and interior furnishings. You can of course create a completely blank floor by selecting the option **None**. In this exercise we want to copy across external walls only, windows and doors. In the **Walls to transfer** drop down list choose the option for **Only exterior walls** and select the checkbox **Windows, doors, openings to copy**.

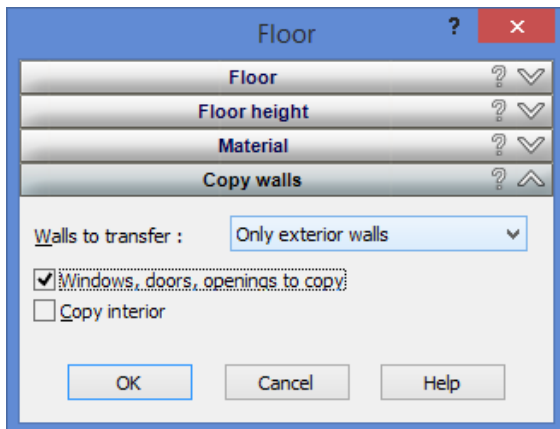

TIP: Any new floor created that consists of elements copied over from existing floor, can be edited as normal. Additional elements can also be inserted in to floor plan.

5. Click **OK** to confirm these settings and switch to **3D Furnishing mode**. Your 3D view will look like the following:

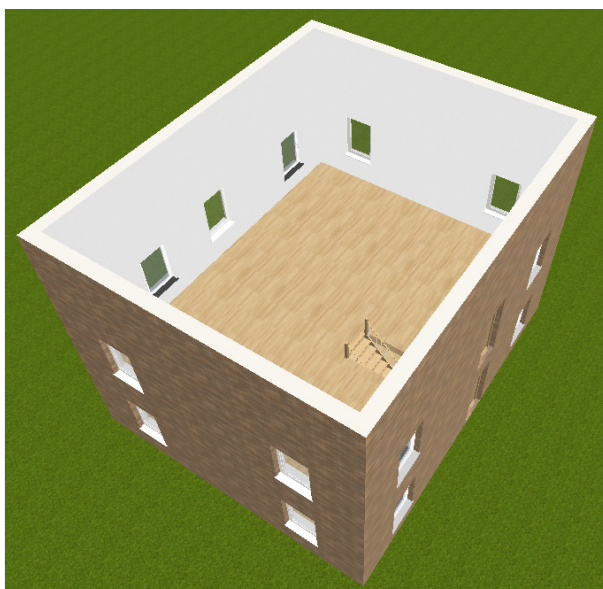

TIP: If you need to make any changes to the ground floor too e.g. create some further rooms, ensure that the floor entry for Ground floor is active in drop down list in horizontal toolbar.

You will see in view that all exterior walls have been transferred across to new floor together with windows, doors and also ceiling cutout where the stairs exist.

Of course, if you want to mirror room layouts over all floors then the simplest way to achieve this is to transfer across all walls, windows, doors etc. In this tutorial, the top floor of building consists of just a single room because we only transferred across the external walls. At this point you might like to practice what you have learnt in previous sections by partitioning off the top floor in to individual rooms. Use the internal wall tool and add windows and doors to your design.

Selecting and deleting construction elements

On this floor we want to delete the door, all windows on side and a window on each gable wall.

1. In **Construction mode** or **3D Furnishing mode**, use the **Selection** tool to select and highlight the elements for deleting. Delete selected elements using the **Delete** key on keyboard or menu item **Edit > Delete > Selection**

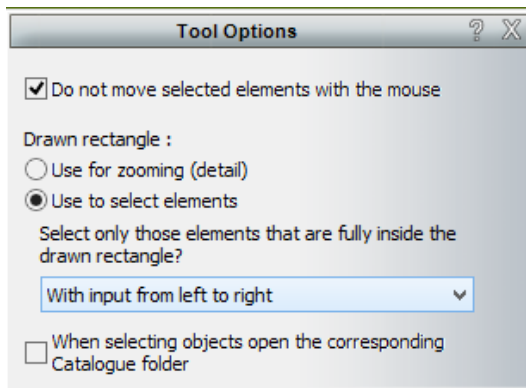

TIP: With the **Selection** tool active, click the **Tool options** icon in the horizontal bar and in the dialogue box that appears you are able to change how this tool functions e.g. drawing rectangle around element to either select it or to zoom in to it.



After selecting and deleting the elements mentioned above, your 3D view should look like the following.

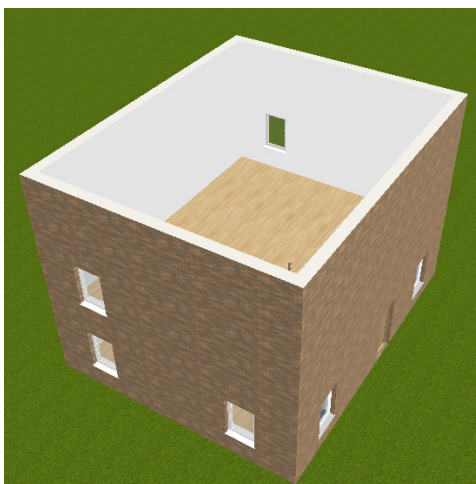

TIP: You are able to select multiple elements whilst holding down the **Shift** or **Ctrl** keys.

After placing the roof, we will use in-line measurements described later on in manual to adjust the position and size of windows on top floor.

Adding a roof to building

Now that a new top floor has been created, a roof can be added.

Switch back in to **Construction mode**. Ensure that the floor entry for **Roof** is active in drop down list in horizontal toolbar and that all floors and all layers are visible (menu **Floors > All Floors Visible**, menu **Layers > All Layers Visible**). The active floor is shown in black together with any visible floors (in this example, the ground floor).

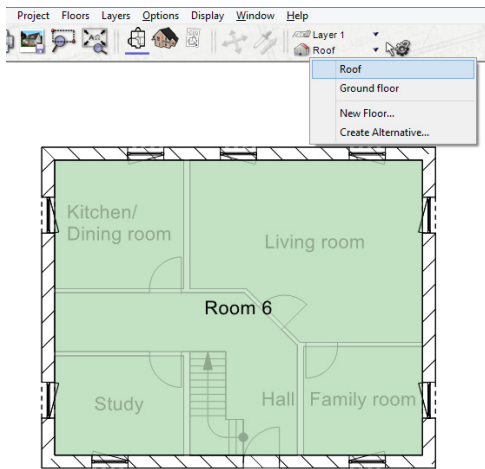

Roofs

Depending on the complexity and style of roof, there are a number of different ways for adding roof to building. One of the most common and easiest methods for adding roofs is by **Automatic Detection**. This method will determine the shape of roof based on the building outline. A standard hipped style roof will be used. Any roof that has been placed automatically or manually can be changed in order to alter all aspects of roof including style and design.

1. Start by left-clicking the **Roofs** icon in the vertical bar on the left.
2. From the fly-out menu select the roof type **Freeform Roof**. Alternatively, select this from the **Roofs** catalogue.

TIP: In the separate **Floors** and **Layers** menu, you can manage how floors and individual layers are displayed. For example, you can display all floors together or if you wish, only make the active floor visible. When you create a new floor, a new entry will be added to the **Floors** drop down list in horizontal toolbar. You select what floor you want to make active from this list e.g.

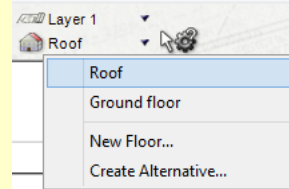

The **Layers** drop down list sits above the floors list. When you add an element to floor plan, this will be assigned to a relevant layer within project that can be controlled and managed in a similar way to floors.

TIP: After left-clicking the **Roofs** icon in the left vertical bar, a selection of roof types are made available in the catalogue bar on the right-hand side of screen under the name **Roofs**.

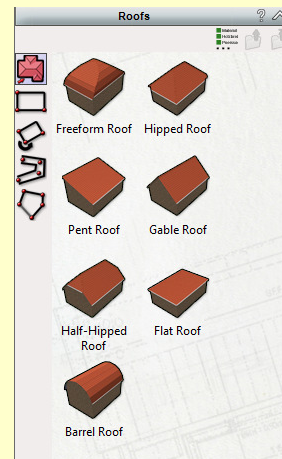

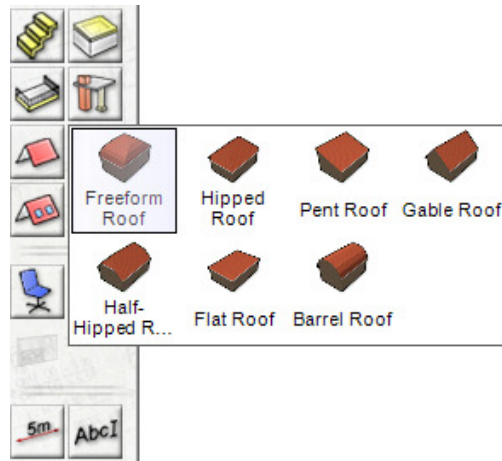

3. Now select the input method **Automatic Detection** (in How bar) from within the catalogue or from the left-side of screen.
4. With this option selected, move your mouse cursor over any of the walls of your building to display the following 2D view of roof. This view will disappear if the mouse cursor is moved away from walls.

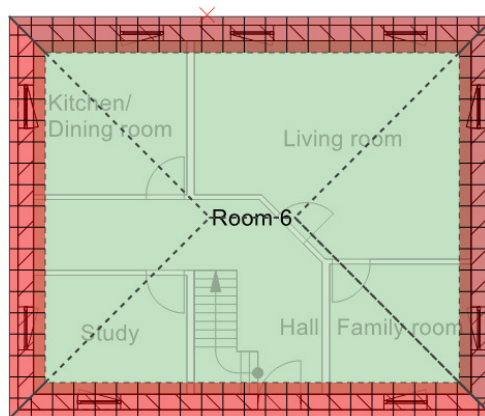

5. With the 2D view of roof showing, left-click your mouse button to place roof in position. To see the placed roof in 3D, switch to **3D Furnishing mode**. As mentioned above, a standard hipped roof has been used for design and in this example you will notice the windows currently protrude through roof. In the next step we will change the roof so that there are two gable ends where the windows currently are.
6. Now switch back to **Construction mode**. Ensure that you are on the active floor i.e. roof. With roof in position, left-click the **Selection** tool and move the cursor over towards the roof. On detection, the outline appearance of roof will highlight. Left-click roof and on selection, various tabs for accessing roof properties become visible in the top horizontal toolbar. Select the tab for **Roof Editor** to open it.

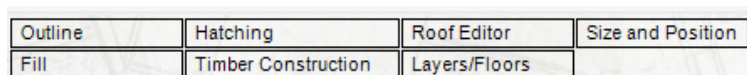

7. The **Roof Editor** dialogue box consists of different tabs that enable you to make various adjustments to all aspects of roof via the use of interactive graphics and/or list view. By clicking on parts of graphic, you are able to make changes to roof style and design quickly and easily. The corresponding values in detailed list view will update accordingly. You can toggle between a graphical display and full list view using the icon in the bottom-right of

dialogue box. In the **2D View** section you can also make settings how the roof appears and behaves in 2D.

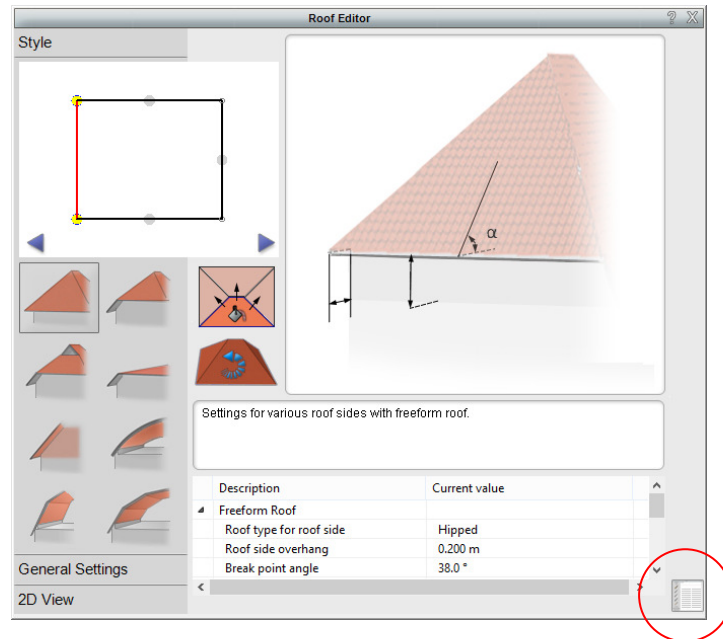

- In the **Style** section, we now want to select and change sides of roof from standard hipped to gable ends. In the top left of dialogue box there is a preview showing the outline of roof shape. Here, you can directly click on side you want to change or use the arrow buttons to switch between sides. The selected side will highlight in red (as above). Select this as the side to change and then select the graphic below for **Gable** roof. The main preview graphic will update accordingly to roof style:

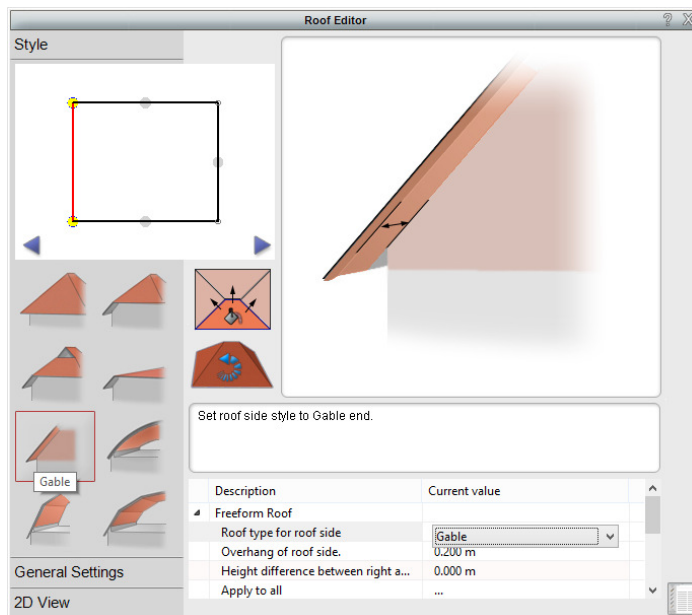

- Repeat this exercise and change the opposite side of roof to gable end also.

In 2D and 3D, your roof with the two gable ends in place should like the following:

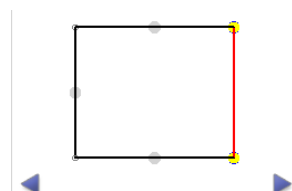

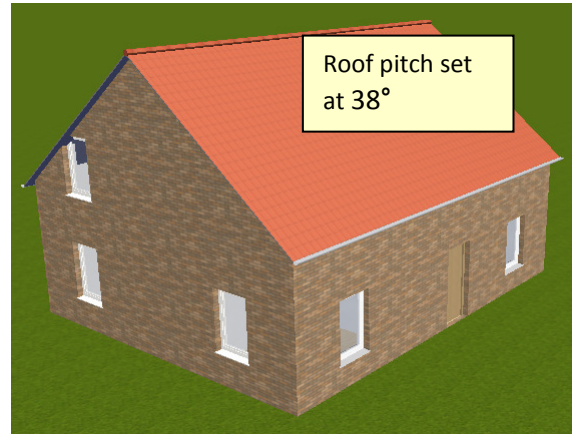
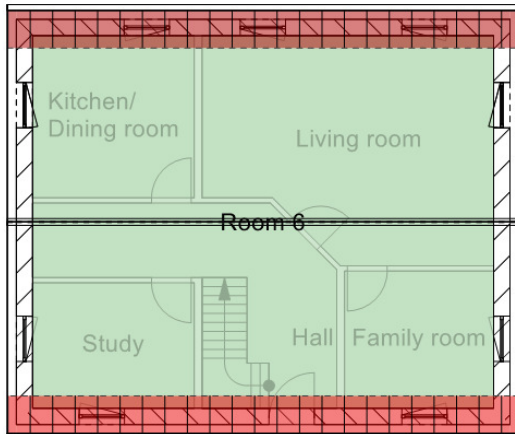

10. Using the **Selection** tool, you can select and change properties of roof in **3D Furnishing mode** also. Select the roof again and open up the **Roof Editor**. This time we want to change the roof pitch in the **Style** section. Select a side of roof that is hipped and in the main preview section, click the graphic element for **Roof side pitch**.

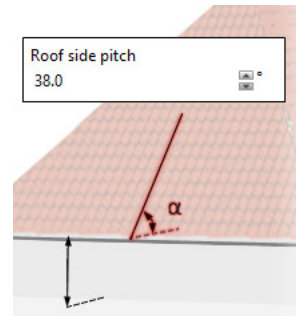
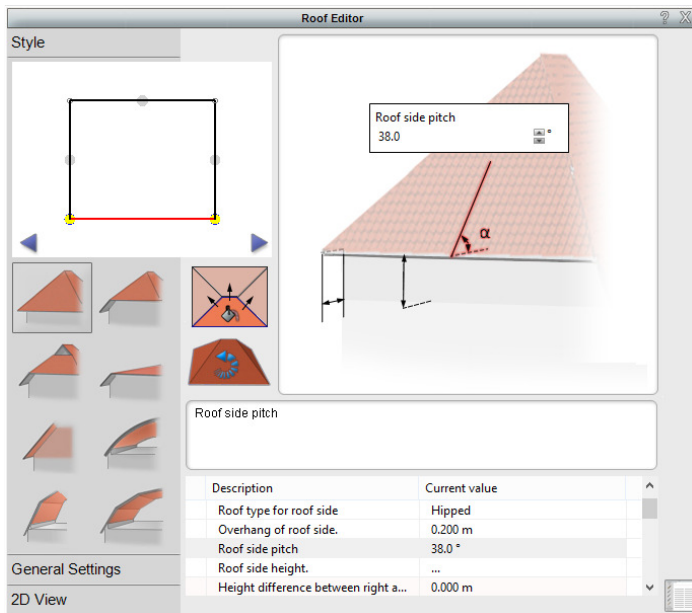

11. In the input box that appears, the default pitch is set at **38°**. Change this value to **45°** and repeat so the roof pitch on opposite side of building is also set to **45°**.

In 3D Furnishing mode, your building should now look like the following.

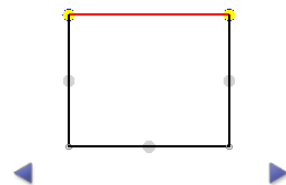

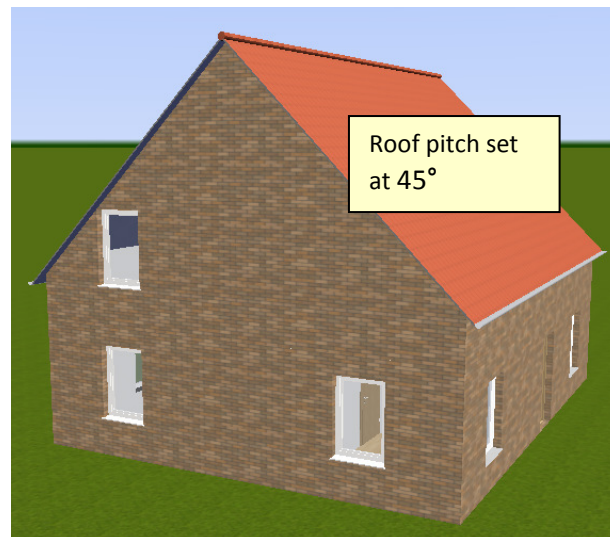

TIP: Although we combined the previous sections with adding a roof, this was to help explain a little about the **Floor** dialogue box, working with floor heights, transferring walls, windows and doors from one floor to another, adding roof, selecting and deleting unwanted elements and in section below, using in-line measurements. We demonstrated how to create a floor assigned to roof however there is another way of achieving this automatically when you add roof directly to uppermost floor.



Select roof type/input method and click the **Tool Options** icon in horizontal toolbar. The following dialogue box will appear. Here you can select the way in which the roof is added to existing floor. For example adding roof to current floor will apply to current floor only, insert attic floor will create new floor for roof to sit on. You have option to create new floor if gable wall extends beyond top floor and you are able to transfer various elements across e.g. walls, windows from current floor. The options behave in similar way to creating an attic floor through Floor menu however these options only apply to roof.

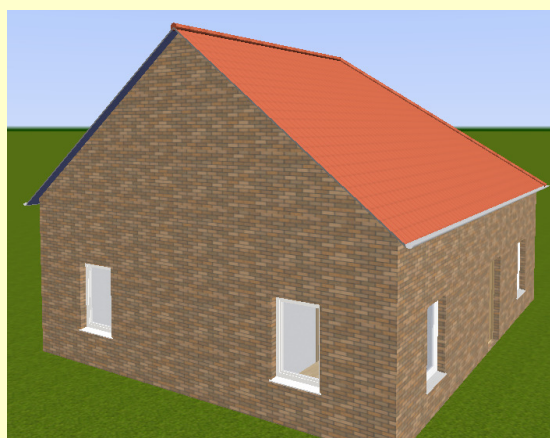
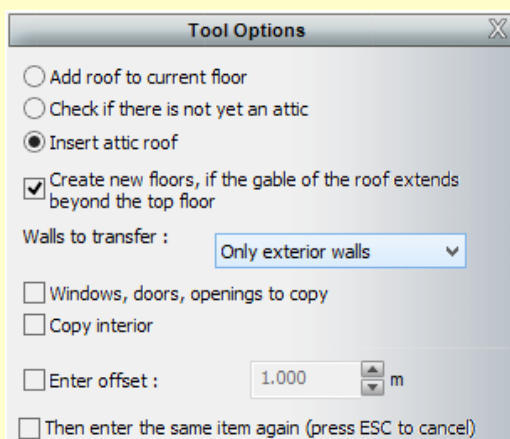

Using in-line measurements

In-line measurements give you greater control and flexibility allowing you to make direct changes around selected elements either on plan or on the 3D model itself. Changes to a selected element are also shown in real time as you change the value in the input field. We will demonstrate this by making some basic changes to the height and position of end windows on the top floor. Once you have learnt how to use the basics of in-line measurements you can practice using this method on other parts of drawing including doors, walls, roof and also on furnishing objects.

1. Firstly, ensure that the in-line measurements display is active in the menu **View > In-line measurements**. So that you can clearly see what you want to change on individual floors, in **Construction mode**, locate and select the menu item **Floors > Only Active Floor is Visible** and in the floor drop down list in horizontal toolbar, select the top floor **Roof**. Only the top floor plan will be shown as follows (a). Using the **Selection** tool, click on one of the windows on end walls. The following in-line measurements will appear around the selected element (b). Different values are shown for example, the width of window and the distances to the inner and outer sides of wall.

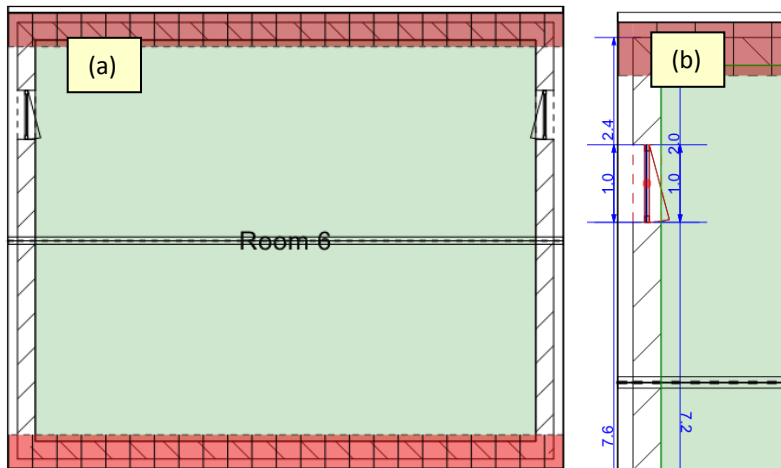

TIP: In the menu **Options > In-line Measurements**, you are able to change various display properties of in-line measurements and how they behave in both Construction mode and 3D Furnishing mode. For example, under the **Dimension Line** tab, you might want to change the appearance of dimension line or end to a different style or size.

The screenshot shows the 'In-line Measurements' dialog box with the following settings:

- In-line Measurements** (checked)
- In-line measurements in 3D** (checked)
- Dimension** (checked)
- Dimension Line** (checked)
- Width:** - 0.18 mm -
- Dimension ends:** Type: Arrow, Fill in ends
- End size:** 0.5 mm
- Extension Line** (checked)
- Buttons: OK, Cancel, Help

2. To change the values, simply move mouse pointer over the desired value of the in-line measurement and when the pointer changes to then edit icon below, left-click to display an input field.



In this exercise click the distance to outer wall value **2.4**.

An input field will appear:

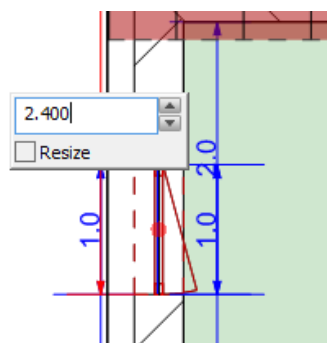

TIP: Always place the cursor to the right of value you want to change e.g.

The screenshot shows the input field with the value '2.400' and a 'Resize' checkbox below it.

3. Now click the mouse cursor to the desired position in the field and change the corresponding value using the mouse wheel or arrows on side. Alternatively you can highlight a value and enter a numeric value from your keyboard. In this exercise, change the value from **2.4m** to **5m** and press the **Enter** on your keyboard or click outside the input field box to

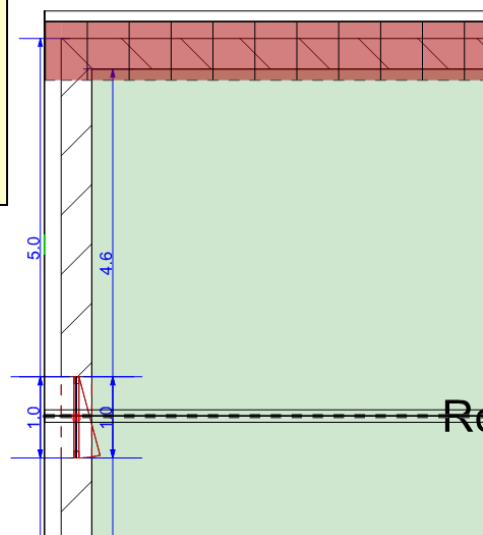

update the window position. The width of window remains unchanged but other values will update accordingly. Repeat this exercise for the window on the opposite side of building.

To see your results in 3D, switch back to **3D Furnishing mode** and select menu item **Floors > All Floors Visible**.

In **3D Furnishing mode**, it is also possible to use in-line measurements. Using in-line measurements in 3D mode enables you to also change height values, such as window and sill heights. In this exercise we will change the height of windows on top floor.

1. Use the **Selection** tool and click on one of the end windows on top floor. The in-line measurements will appear around the selected element in 3D. Moving the mouse cursor over each value will display what this value refers to on model e.g. width, sill height, position etc.
2. To adjust the height of window, click the value **1.5m** and enter a new value of **1m** using the same input methods as mentioned above. Now adjust the window sill height by clicking on value **0.8m** and increasing this to **1.3m**. The changes are displayed instantly. Repeat this exercise for the window on the opposite side of building.

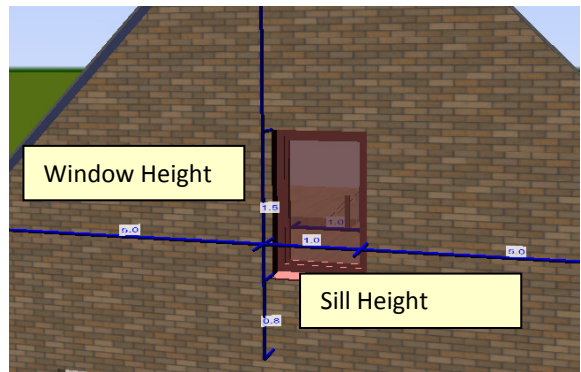
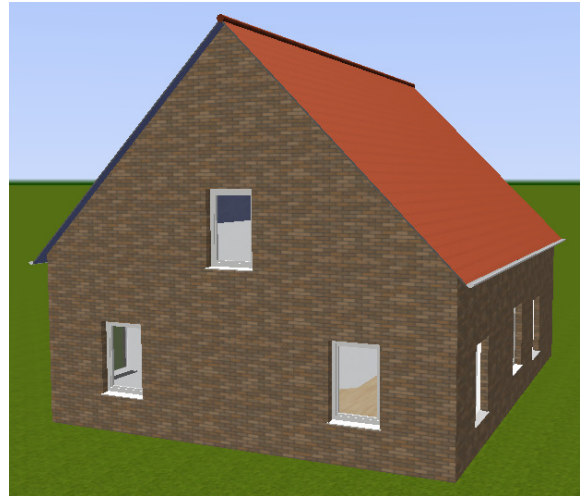

Your finished result should look like the following.

At this point you can also adjust height of any other windows in project e.g. to ground floor.

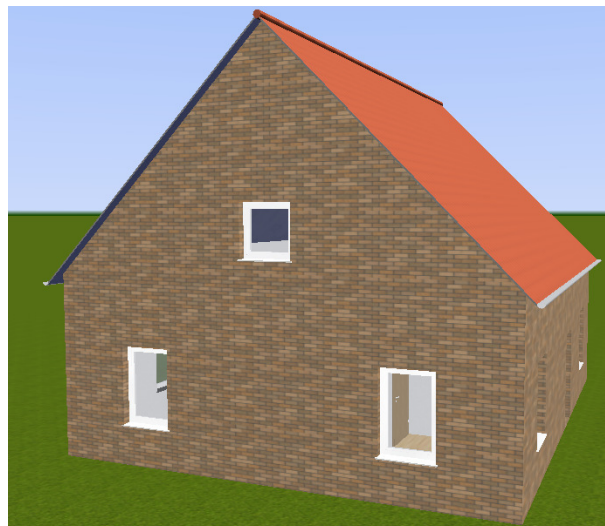

Adding skylights to existing roof



In **Construction mode** ensure that the floor entry for **Roof** is active in drop down list in horizontal toolbar.

1. Start by left-clicking the **Skylights** icon in the vertical bar on the left. From the fly-out menu or from **Skylights** catalogue, select a skylight of choice.
2. Once you have selected a skylight, move the mouse cursor over towards the edge of roof to where you want skylight placed (approximate position). On detection, the outline appearance of roof will highlight green.
3. Now left-click mouse button and the skylight will attached itself to pointer so you can move it about until you find the desired position. To place the skylight in position, left-click mouse button again.

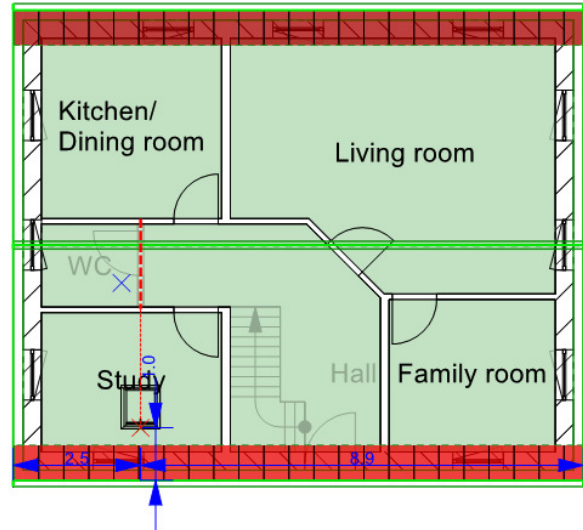

In **Construction mode** or **3D Furnishing mode**, use the in-line measurements to change its size and position.

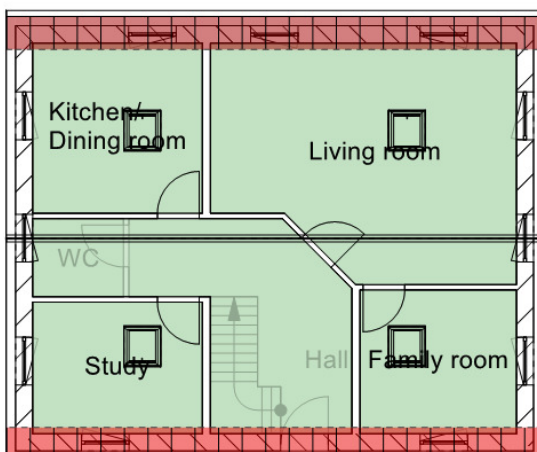
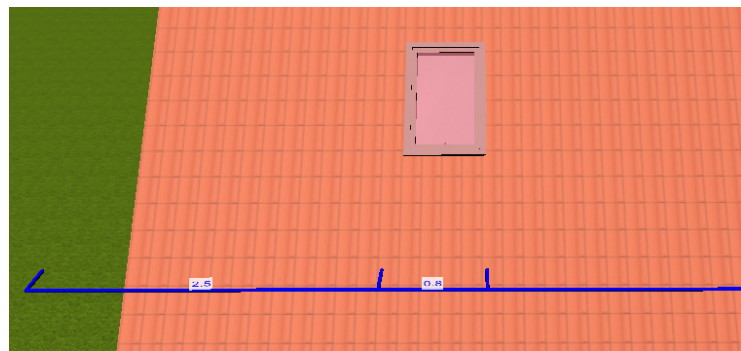

2D and 3D example of skylights

Furnishing Your Project

Once you are happy with the layout of your design, you can start adding furnishing objects and materials to help bring your design to life and give you a real feel of the living space you have just created. The software comes included with a number of individual databases that contain 1,000's of objects and textures to choose from. If you locate the menu item **Options > Database...** you can see what databases have been registered to use in program. Each database contains items for different aspects of program such as construction elements, 2D drawing symbols and objects and materials.

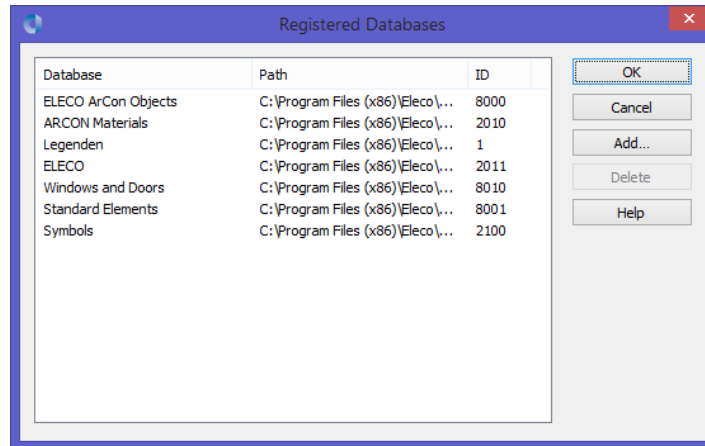

Furnishing objects, textures and materials can be applied to project in both **Construction mode** and **3D Furnishing mode**. Placing objects in **Construction mode** gives you greater control and accuracy when laying them out in a plan view.

Objects

So that you can clearly see what you want to change on individual floors, in **Construction mode**, locate and select the menu item **Floors > Only Active Floor is Visible** and in the floor drop down list in horizontal toolbar, select **Ground floor**. Only the ground floor will be shown.

1. In this tutorial we will place some furniture items in the kitchen/dining room area of your plan.
2. Start by left-clicking the **Objects** icon in the vertical bar on the left.
3. From the fly-out menu you can select a recently used object or one from the main **Objects** catalogue on right of screen.

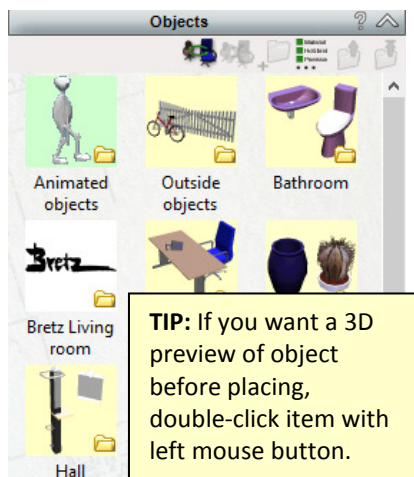

4. In the **Objects** catalogue, scroll through the catalogue, locate and double-click the **Kitchen** folder followed by **Set 1 > Short cabinets 1**.
5. Locate and click the object for **Corner cabinet 90cm**. Move cursor over towards the room you want to place object in. The object attaches itself to the cursor.
6. We want to place the corner cabinet in the top-left of kitchen/dining area so move the object to the corner of room until the object snaps to the two adjoining inside walls as follows (a). This is your fixed reference point for object.

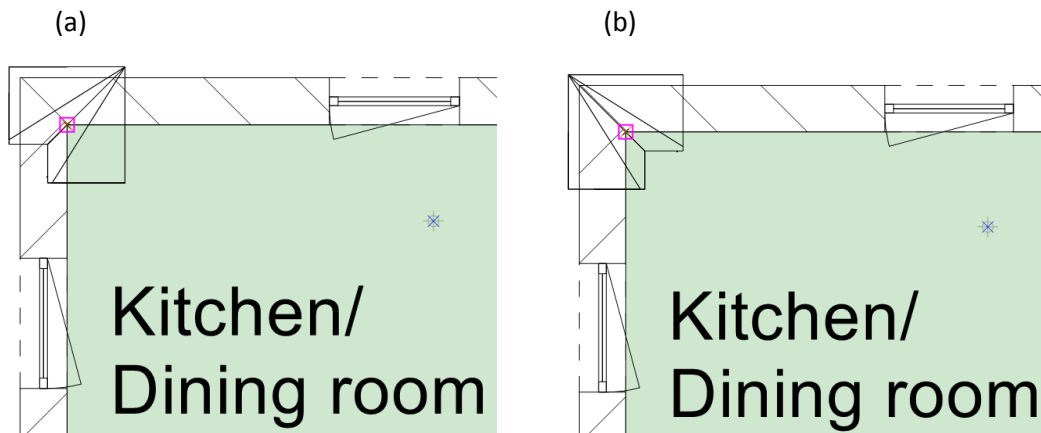

7. In the above example (a) the cabinet needs rotating so that the corner cabinet doors are facing out in to the room. Using the key combination **Ctrl + D** rotate object so that it looks like example (b).
8. Now you need to position the object correctly so that the back edges of object fix to wall edge. This is determined by the object snap point which you can change using the key combination **Ctrl + W**. Use this key combination to get the following result. Place object in position by left-clicking mouse button.



9. In the same objects folder, select object for **Short cabinet 100cm** and use the same steps as above to place this object either side of corner cabinet so that you end up with following result.

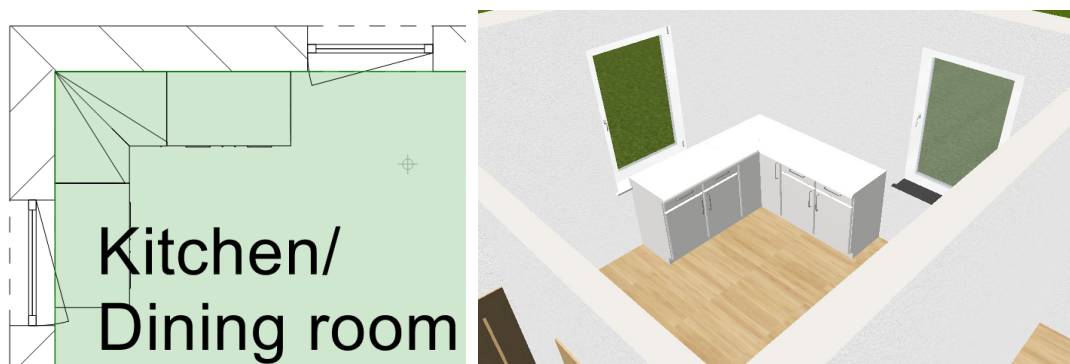

10. The size and position of placed objects can of course be modified afterwards in both **Construction mode** and **3D Furnishing mode** using various methods via in-line measurements or tabs in horizontal bar.



TIP: In addition to making changes to objects, at this point you can also make any necessary changes to other parts of plan. In this example, using in-line measurements, we will make adjustments to the window sill heights from 0.8m to 1m so that the sill sits above worktop. Resize so the window height adjusts accordingly. See example on left.

11. If for example you have a placed a hanging cabinet that is currently set so that it is sitting on ground floor level, left-click object and select the tab **Size and Position** from the horizontal bar. In the top section of dialogue box you can specify position of object in relation to reference point. The entry for **Z (height)** lets you determine height from floor to object.
12. In the **Set 1 > Hanging cabinets** folder, select the object for **Corner hanging cabinet** and place this above the corner cabinet on base level using the same steps as above. Now left-click to select it and click the tab **Size and Position** from the top horizontal bar. As described above, in the input box for **Z (height)** enter **2m**. The object will reposition itself 2m from the ground floor as in example below.



Materials

There are a number of different ways to apply materials to your design from the registered databases that comes included with program. One of the easiest and quickest ways is in **3D Furnishing mode**.

1. In this tutorial we will apply some wall and floor materials in the kitchen/dining room area of your plan.
2. Start by left-clicking the **Materials** icon in the vertical bar on the left.
3. From the fly-out menu you can select a recently used materials or one from the main **Materials** catalogue on right of screen.

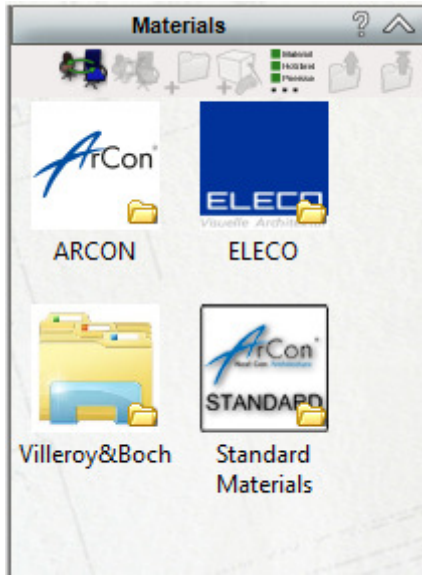

4. In the **Materials** catalogue, double-click the **ELECO** folder. Open the **Tiles** folder and left-click to select **Beige_Tile-02**. Move cursor over an area of room you want to apply material to and the cursor symbol will change its appearance to a paint bucket. If there is a part of the design where you are not permitted to apply material to, the paint bucket symbol will also include a 'no entry' symbol.
5. With the above material selected left-click to apply this to the floor area to get the following result (a)
6. Now locate any colour from the main **ARCON** database and apply this to the walls e.g. (b)
7. By applying materials using this method, all adjoining facing walls will change together. You can apply different materials/textures to individual walls or other aspects of building using the **Editing tools** in **3D Furnishing mode** as follows.

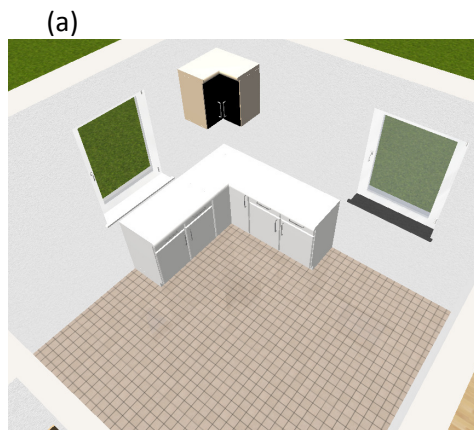

8. In **3D Furnishing mode**, left-click the **Tools** icon in the vertical bar on the left 
9. From the fly-out menu you can select specific tools or one from the main **3D Tools** catalogue on right of screen.



10. Left-click to select tool for **Edit material**
11. Hold down the **Shift** key on your keyboard and then left-click the wall you would like to apply a different material to.

12. The **Material settings** dialogue box will appear.

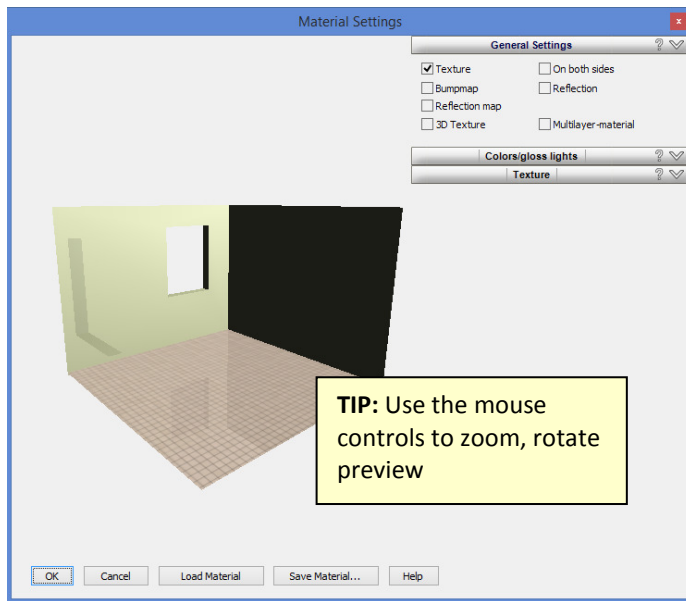

TIP: If you want to select and apply a material from one part of your building design project to another e.g. duplicate a floor tile to another part of building, use the Texture/Material picker tool in the horizontal bar.



Left-click this icon and the cursor symbol will change to a pipette. Left-click on the material you want to select and use again and the symbol will change to a paint bucket symbol you will already be familiar with.



Apply material in the same way by left-clicking on part of the design you want the material to go.

13. In this dialogue box you have advanced settings for changing the properties of material which you can experiment with later on in project. In this tutorial we want to apply a different material to individual wall. Click the **Load material** button and select a different colour or texture from the one before and click **OK** to confirm settings.

14. If you wish to change parts of the building that have a transparent material for example a window panel, hold down the **Ctrl** key on your keyboard and then left-click it to open above dialogue box and change material in the same way as described in previous steps.

Applying materials to objects

With some objects in the database you are able to apply different materials to parts of object either by dropping it on to object in the normal way as described in step 1, or using the **Edit material** tool option as mentioned above. The different methods for doing this depend on the object itself and how the object was originally created or modelled. Practice these methods on the kitchen units that have already been placed in project e.g. change the worktop surface to a material of choice or change the cabinet doors to a different colour.

Scaling a texture

The 3D Tools catalogue also contains a selection of tools including tools for moving and scaling textures. Left-click the tool for **Scale Texture** and move the cursor over the floor area in kitchen/dining room with the left-mouse button held down. Notice that the texture size will scale up or down depending on the direction you are moving the mouse in. In this exercise, I have scaled the texture so that the floor tiles appear bigger than before. I've also used the **Move Texture** icon to position the texture correctly.



Material area

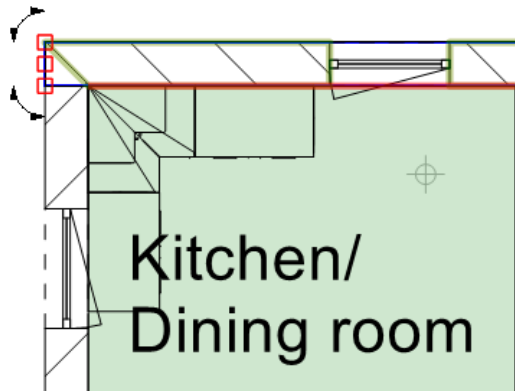

Quite often there are parts of the building where you want to define for example a small area for texturing. This might include a brick soldier course above window or a tile splashback over kitchen units. To do this you first need to be in **Construction mode**.

1. Left-click to select the inside or outside of wall where you want material area applied to.

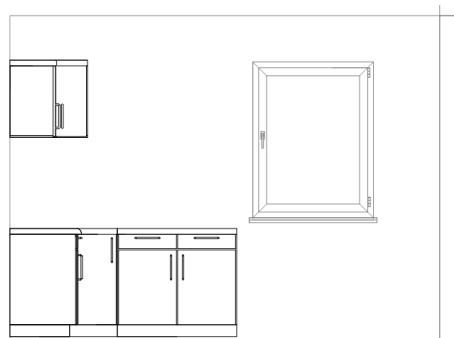

2. The selected wall side will highlight in a thick red line as above.
3. Double-click selected wall with left mouse button.
4. An elevation view of selected wall will display with relevant construction elements, objects etc in place. The elevation view might also be displaying grid which can be turned off via **View** menu or **Grid** icon in bar at bottom of screen.



5.  To define an area in this mode, start by left-clicking the **Material area** icon in the vertical bar on the left. An additional vertical bar will appear (*How bar*). This bar determines the input method of the material area.
6. Select the input method for **Material Area (Polygon at fixed width)**
7. In this tutorial we will add an area of tiles to wall over kitchen unit at fixed width. Using this method will help to tile an area on adjoining wall at same size.
8.  With **Material Area (Polygon at fixed width)** selected, click the **Tool Options** icon in horizontal toolbar and in the dialogue box that appears enter **0.4m** in to field.
9. Click to set the start point of line (a). Draw out rectangle and press **Ctrl + click** to set second point to complete rectangle (b).

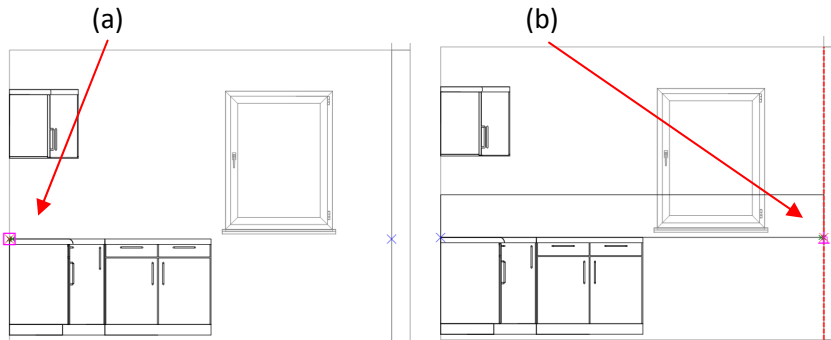

TIP: Before placing rectangle in position, use the key combination **Ctrl + W** to determine placement of rectangle in relation to reference point.

10.  You can select and edit the drawn area using the **Selection** tool in vertical bar on left. On selection of drawn area, various tabs for accessing properties become visible in the top horizontal toolbar including materials.
11. If you wish to change the material in **3D Furnishing mode**, follow the steps as described in previous sections.

TIP: Drawing material area over a component part that includes a cut-out, sill etc e.g. window, automatically creates cut-out in material area. You can see the effect of this in detail in 3D mode. If necessary you can use other input methods e.g. **Material Area (Polygon)** for drawing around more complicated parts of drawing. Note, when drawing detailed material area use mouse controls for zooming and panning as required.

12.  To exit this mode and return to **Construction mode**, click the **Back to the main plan** icon in the top horizontal bar of screen. To tile another area, click on wall side and repeat steps.
13. Here is an example of tiled area over two walls.



TIP: If you want to edit a material area or add another material area to wall, just double left-click relevant wall side in **Construction mode** to open up editor.

Apply lighting and shadow effects

To enhance the appearance of your model, there are pre-set lighting scenes that can be applied to your project at any time. Locate the **View > Lighting > Lighting variants** menu and select **Daytime, light shadows** from list. Now select the menu item **View > Shadows**. This will calculate where shadows will cast in accordance with the lighting conditions. You can also use relevant icon in bar at bottom of screen for turning shadow display on and off.

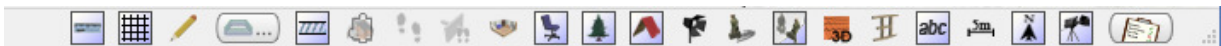

Following example is of kitchen/dining room with some extra furniture items in place and lighting scene on.



TIP: You can also create your own lighting scenes in the menu **View > Lighting > Lighting variants > New lighting scene**

Having worked through this complete section you should have learnt some basic techniques on how to furnish your project using objects, materials and other effects. To get the best output, experiment with advanced settings and other techniques the software has to offer in particular lighting scenes and materials. In the **Material settings** dialogue box there are advanced settings for texturing that include 3D textures, animation and tiling, bump and reflection map capabilities, colours and gloss lighting effects.