

# Plan7Architect

© 04/2026 Immocado UG

# Publisher

Immocado Entrepreneurial company (limited liability)  
Technologie-Quartier Bochum  
Konrad-Zuse-Straße 10  
44801 Bochum

Email: [info@plan7architect.com](mailto:info@plan7architect.com)  
Tel.: +1 844 214 9561



## Important Notice:

This program help guide has been prepared with the utmost care. Although every effort has been made to ensure that the information and data contained in the manual and program help guide are up-to-date and accurate, no guarantee can be given that they are free of errors. Neither legal responsibility nor liability can be accepted for any incorrect information or its consequences.

## Immocado Entrepreneurial Company (Limited Liability)

All rights reserved. Reproduction and duplication—including in part or by electronic means—are prohibited.

This manual **applies to all versions of Plan7Architect**, but is based on Plan7Architekt Ultimate, which offers the widest range of features. **Therefore, some of the functions described here may vary.**

In addition to this manual, you will find numerous video tutorials on **YouTube** regarding project work with the software:

<https://www.youtube.com/@Plan7Architect>

We offer all customers one year of free support via email and our ticket system after purchase. Our staff will be happy to assist you with any questions you may have:

**Create a support ticket:** <https://plan7architect.com/supportticketsystem/>

(You must first log in to your customer account at <https://plan7architect.com/my-account/>)

**Email support:** [info@plan7architect.com](mailto:info@plan7architect.com)

# Table of Contents

Foreword	0
<b>Part I Introduction</b>	<b>17</b>
1 Version note .....	18
2 Hardware and software requirements .....	18
<b>Part II Licensing</b>	<b>21</b>
<b>Part III Application menu - File management (load/save/save)</b>	<b>24</b>
1 Useful information for experienced users .....	26
2 Import/Export .....	28
<b>IFC interface</b> .....	<b>28</b>
Import General .....	29
General information on importing.....	29
Site building storeys .....	30
Walls .....	30
Rooms .....	30
Windows - Doors .....	31
Roof .....	31
Blankets .....	31
Supports .....	31
Beams .....	32
3D-Objekte .....	32
cannot be read in .....	32
Import IFC file .....	32
Export IFC file .....	34
<b>DWG/DXF</b> .....	<b>35</b>
Define the drawing unit .....	36
Terrain import .....	39
Open or import .....	40
Exporting DWG/DXF .....	41
DXF and DWG file format .....	45
<b>Image files</b> .....	<b>45</b>
Import image files .....	45
Import image file button.....	46
Export image files .....	48
From the 2D modes.....	48
From 3D mode.....	49
Scan-Wizard .....	50
Reload drawing (image).....	50
Optimize drawing (image).....	51
Alignment .....	52
Determine scale.....	53
Catch points .....	54
<b>PDF</b> .....	<b>55</b>
Read PDF as bitmap .....	55
Read PDF with vectors .....	58

Output PDF .....	59
Export PDF with vectors .....	60
<b>3D Models</b> .....	<b>62</b>
Export 3D-VRML .....	62
Export 3DS .....	64
Export X3D .....	65
Export as panorama .....	66
Import Sketchup SKP .....	68
Other providers .....	68
<b>3 Program</b> .....	<b>68</b>
Save .....	68
Saving objects and textures in the project .....	71
Summary of the settings for loading and saving .....	73
Program settings .....	75
Creating or changing the standard.cad .....	78
<b>4 Print</b> .....	<b>79</b>
<b>Part IV Basic knowledge</b> .....	<b>83</b>
<b>1 Surface</b> .....	<b>83</b>
The surface .....	83
The modes .....	85
Mouse operation .....	86
Edit .....	87
Protect component .....	93
<b>2 Coordinate systems</b> .....	<b>96</b>
What are coordinates .....	96
What do you need coordinates for? .....	96
The Cartesian coordinate system .....	96
The polar coordinate system .....	97
Zero point .....	98
Operating point .....	98
dx, dy - relative Cartesian .....	99
x, y - absolute cartesian .....	100
dl, a - relative polar .....	101
l, a - absolute polar .....	101
dl - direction and distance .....	101
Entering coordinates, further examples .....	102
<b>3 The structure of projects</b> .....	<b>103</b>
<b>Layer</b> .....	<b>104</b>
What is the active layer? .....	104
Create a new layer .....	106
Delete a layer .....	109
Rename layer .....	111
Edit layer .....	111
Which layers should be created? .....	112
Layer assignment for drawing elements .....	112
Visible layers .....	113
Layer always protected .....	114
Protected layers .....	114
Layers in the model, in views and plan layouts .....	115
Layer set .....	116
Loading and saving layers .....	118

<b>Storeys</b> .....	<b>119</b>
What is the active projectile? .....	120
Create a new storey .....	121
Delete a projectile .....	124
Editing a floor .....	125
Dependencies between storeys .....	125
Visible storeys .....	126
Protected floors .....	127
Wooden construction .....	128
General .....	129
Cross sections .....	131
Material for timber construction .....	132
<b>4 General property dialogs</b> .....	<b>134</b>
<b>Change colors</b> .....	<b>134</b>
The color selection dialog .....	136
<b>2D representation</b> .....	<b>136</b>
Contour .....	138
Fillings .....	140
Hatching .....	141
<b>Line ends</b> .....	<b>142</b>
<b>Extend</b> .....	<b>142</b>
<b>Special catch points</b> .....	<b>143</b>
<b>Layer/Floor</b> .....	<b>143</b>
<b>Size/Position</b> .....	<b>143</b>
<b>Labeling</b> .....	<b>144</b>
<b>Surface/Material</b> .....	<b>145</b>
<b>Properties</b> .....	<b>145</b>
<b>Position number</b> .....	<b>147</b>
<b>Light source</b> .....	<b>148</b>
<b>Component catalogs</b> .....	<b>150</b>
Catalogs - Component templates .....	150
What are component templates? .....	150
Save new component template .....	150
Deleting a component template .....	151
Save current values .....	152
Move component templates to another directory .....	153
Standards .....	153
Databases for component templates .....	154
<b>Catalog Explorer</b> .....	<b>157</b>
The content area .....	160
Search .....	164
<b>Part V Options</b> .....	<b>165</b>
<b>1 Online dimension settings</b> .....	<b>165</b>
<b>2 Options_Catch</b> .....	<b>167</b>
<b>3 Databases</b> .....	<b>168</b>
Select databases for saving .....	170
<b>4 Zoom, Screen layout and Drawing aids</b> .....	<b>174</b>
Selection .....	174
Zoom and pan (move) .....	176
Catch .....	176
Crosshairs .....	180

Online dimensions .....	180
Online dimensions for wall segments .....	183
Shortcut keys .....	185
<b>Part VI Display</b>	<b>188</b>
<b>Part VII Freely configurable toolbars</b>	<b>189</b>
<b>Part VIII Window layout</b>	<b>192</b>
<b>Part IX Toolbar grid</b>	<b>193</b>
1 Grid .....	194
<b>Part X Toolbar view</b>	<b>197</b>
1 in a 2D mode .....	197
Review assistant .....	198
Sketch settings .....	198
2 Excerpts .....	200
3 in a 3D mode .....	201
<b>Part XI Ribbon project</b>	<b>203</b>
1 North direction .....	203
2 Labeling .....	204
General .....	204
Rooms .....	206
Windows/Doors/Wall recesses/Roof windows .....	208
Stairs .....	209
Groups .....	210
Terrain heights .....	211
Roof windows .....	212
3 Room info .....	212
4 Contour lines .....	214
5 Roof intersection .....	214
6 Project properties .....	215
7 Level of detail_view .....	216
8 Level of detail_default settings .....	217
9 External dimensions .....	217
10 Master data synchronization .....	218
11 Delete unattached rooms .....	219
<b>Part XII Ribbon construction</b>	<b>220</b>
1 Walls .....	220
Introduction .....	220
Representation in floor plan .....	220
Wandsegmente .....	221
3D representation .....	221

Influence on other components .....	221
Important shortcut keys .....	222
Wall axles .....	223
<b>Wall input .....</b>	<b>224</b>
Drawing .....	224
Numerical input .....	227
<b>Polygonal walls (polywall) .....</b>	<b>228</b>
Basics .....	228
Input .....	229
Edit .....	229
Masses .....	229
Wall structure .....	229
<b>Property dialogs for walls .....</b>	<b>230</b>
Catalogue .....	231
Construction .....	231
Wall surfaces .....	234
2D Representation .....	234
Properties .....	235
Layer/Floor .....	235
Size/Position .....	235
<b>Editing walls .....</b>	<b>235</b>
Extend .....	235
Move .....	236
Trimming .....	236
<b>2 Virtual walls .....</b>	<b>236</b>
<b>Property dialogs .....</b>	<b>237</b>
Catalogue .....	237
Wall .....	238
Levels .....	238
Contour .....	238
Properties .....	239
Position number (PosNr) .....	239
Layer/floor .....	239
Size/position .....	239
<b>Tips .....</b>	<b>239</b>
<b>3 Supports .....</b>	<b>240</b>
<b>General information .....</b>	<b>240</b>
<b>Draw supports .....</b>	<b>241</b>
<b>Change supports .....</b>	<b>243</b>
<b>Move supports .....</b>	<b>244</b>
<b>Cutting supports under roofs .....</b>	<b>245</b>
<b>Delete supports .....</b>	<b>246</b>
<b>Property dialogs .....</b>	<b>246</b>
Catalogue .....	246
Dimensions/Level .....	247
Support feet, Support heads .....	247
Contour/Fill/Hatching .....	250
Surface .....	250
Properties .....	250
Layer/Floor .....	250
Size/Position .....	251
<b>Influence on other components .....</b>	<b>251</b>
<b>4 Beams .....</b>	<b>251</b>

<b>General information</b> .....	<b>251</b>
<b>Draw downstand beam</b> .....	<b>251</b>
<b>The input bar</b> .....	<b>252</b>
<b>Property dialogs</b> .....	<b>252</b>
Catalogue .....	252
Downstand beam .....	253
Contour/Fill/Hatching .....	254
Surface .....	254
Properties .....	254
Masses .....	254
Position number (PosNr) .....	254
Layer/Floor .....	254
Size/Position .....	254
<b>5 Profiled Beams</b> .....	<b>255</b>
<b>General information</b> .....	<b>255</b>
<b>Draw bars</b> .....	<b>255</b>
Input types .....	256
<b>The input bar</b> .....	<b>257</b>
<b>Property dialogs</b> .....	<b>257</b>
Catalogue .....	257
Light source .....	257
Beams .....	257
Cross section.....	258
Draw cross section yourself.....	259
Beam/Honoring.....	261
2D representation .....	262
Surface .....	263
Properties .....	263
Masses .....	263
Level .....	263
Position number (PosNr) .....	263
Layer/Floor .....	263
Position .....	263
<b>6 Ceiling</b> .....	<b>265</b>
<b>General information</b> .....	<b>265</b>
<b>Drawing</b> .....	<b>266</b>
Input types .....	266
<b>The overview bar</b> .....	<b>267</b>
<b>Property dialogs</b> .....	<b>267</b>
Catalogue .....	267
Level/Structure .....	268
Wooden Construction .....	268
General .....	269
Cross sections.....	270
Material for timber construction.....	272
Contour/Fill/Hatching .....	272
Surface .....	272
Properties .....	273
Masses .....	273
Layer/Floor .....	273
Size/Position .....	273
Edit points .....	273
<b>7 Ceiling openings</b> .....	<b>273</b>

<b>General information</b> .....	<b>274</b>
<b>Drawing</b> .....	<b>274</b>
Input types .....	274
<b>The overview bar</b> .....	<b>275</b>
<b>Property dialogs</b> .....	<b>275</b>
Ceiling opening .....	275
<b>8 Plates</b> .....	<b>276</b>
<b>Drawing</b> .....	<b>276</b>
Input types .....	276
<b>Property dialogs</b> .....	<b>277</b>
Catalogue .....	277
Plate .....	278
Surface .....	282
Border .....	283
Layer/Floor, Size/Position, Contour/Fill/Hatching .....	285
Edit points .....	286
<b>Edit</b> .....	<b>286</b>
<b>9 Windows/Doors/Wall Recesses/Roof Windows</b> .....	<b>286</b>
<b>Overview of wall openings</b> .....	<b>286</b>
<b>Place</b> .....	<b>287</b>
<b>Position</b> .....	<b>288</b>
<b>The overview bar</b> .....	<b>289</b>
<b>Property dialogs</b> .....	<b>289</b>
Catalogue .....	289
Component .....	290
General settings.....	291
Selection .....	293
Shading elements on the window.....	294
2D replacement display.....	298
Corner/Miter design.....	299
Window sills.....	300
Window pockets.....	301
Material .....	302
Labeling .....	303
Properties .....	303
Layer/Floor .....	303
Position .....	303
<b>Advanced editing/window designer</b> .....	<b>304</b>
General settings .....	304
Wings .....	308
Frame .....	310
Rungs .....	312
Shelves .....	313
Objects .....	316
Recesses .....	318
Creation of a new window/window section .....	319
Georgian bars and Frame components .....	323
Placing objects at the window .....	326
Door-window combinations .....	328
<b>10 Roofs</b> .....	<b>330</b>
<b>General information</b> .....	<b>330</b>
<b>Drawing</b> .....	<b>331</b>
Input types .....	331

<b>Property dialogs</b> .....	<b>332</b>
Catalogue .....	332
Roof .....	333
General .....	333
Roof side .....	334
2D representation .....	338
Wall and roof intersection .....	339
Wooden construction .....	340
Machining wooden structures .....	340
Fill/Hatching/Contour .....	341
<b>Roof editing mode</b> .....	<b>341</b>
Editing the roof sides .....	342
Roof openings and roof side extensions .....	343
<b>Blending roofs</b> .....	<b>346</b>
<b>11 Dormer windows</b> .....	<b>347</b>
<b>Drawing</b> .....	<b>347</b>
<b>Property dialogs</b> .....	<b>348</b>
Catalogue .....	348
Fill/Hatching/Contour .....	348
<b>12 Roof windows</b> .....	<b>348</b>
<b>Drawing</b> .....	<b>348</b>
<b>The overview bar</b> .....	<b>349</b>
<b>Property dialogs</b> .....	<b>349</b>
Catalogue .....	349
Component .....	351
<b>13 Foundations</b> .....	<b>352</b>
<b>Input bar</b> .....	<b>352</b>
<b>Property dialogs</b> .....	<b>352</b>
Catalogue .....	352
Foundations .....	352
Contour /Fill/Hatching .....	353
Material .....	353
Properties .....	353
Masses .....	353
Position number (PosNr) .....	353
Layer/Floor .....	353
<b>Self-funding</b> .....	<b>354</b>
Size/Position .....	354
<b>14 Stairs</b> .....	<b>354</b>
<b>General information</b> .....	<b>355</b>
<b>Draw stairs</b> .....	<b>355</b>
<b>The overview bar</b> .....	<b>358</b>
<b>Property dialogs</b> .....	<b>358</b>
Catalogue .....	358
Staircase/Shape .....	358
Dimensions .....	358
Design .....	360
Editing stairs .....	361
Calculation .....	364
2D representation .....	370
Ceiling opening .....	372
Labeling .....	373
Properties .....	373

Position number (PosNr) .....	373
Layer/Floor .....	374
Size/Position .....	374
<b>Influence of or on other components .....</b>	<b>374</b>
<b>15 Railing .....</b>	<b>375</b>
<b>Drawing railings .....</b>	<b>375</b>
Input types .....	376
<b>Property dialogs .....</b>	<b>376</b>
Catalogue .....	376
Railing .....	377
General information.....	377
Post .....	379
Handrail .....	383
Filling .....	383
Materials .....	385
2D representation .....	385
Contour .....	385
Properties .....	386
Masses .....	386
Layer/Floor .....	386
Size/Position .....	386
Position number (PosNr) .....	386
<b>16 Zones .....</b>	<b>386</b>
<b>Create zone .....</b>	<b>386</b>
<b>Rename zone .....</b>	<b>386</b>
<b>Delete zone .....</b>	<b>386</b>
<b>Assign zone .....</b>	<b>387</b>
<b>17 Rooms .....</b>	<b>387</b>
<b>General information .....</b>	<b>387</b>
<b>Property dialogs .....</b>	<b>387</b>
Catalogue .....	388
Room data .....	388
Labeling .....	390
Contour .....	393
Filling and Hatching .....	394
Materials .....	394
Levels .....	395
<b>Room stamp .....</b>	<b>396</b>
<b>Room info .....</b>	<b>397</b>
<b>Rounding .....</b>	<b>399</b>
Contour lines .....	400
<b>Assign rooms .....</b>	<b>402</b>
<b>Assign apartments .....</b>	<b>403</b>
<b>Unbound rooms .....</b>	<b>404</b>
<b>Copy rooms .....</b>	<b>406</b>
<b>Part XIII 3D-Modus .....</b>	<b>408</b>
<b>1 Navigation in 3D mode .....</b>	<b>408</b>
<b>2 Perspective .....</b>	<b>409</b>
<b>3 Display quality .....</b>	<b>411</b>
with bump and reflection map .....	412
Simply textured .....	413

Untextured .....	413
Illuminated contours .....	413
Black contours .....	414
Concealed edges .....	414
Shading with edges .....	415
<b>4 Background .....</b>	<b>416</b>
<b>5 3D cut .....</b>	<b>419</b>
<b>6 Collision control .....</b>	<b>420</b>
<b>7 Catch .....</b>	<b>420</b>
<b>8 Measuring in 3D mode .....</b>	<b>421</b>
<b>9 Light and shadow .....</b>	<b>426</b>
<b>General information .....</b>	<b>426</b>
Light components .....	426
Ambient light (ambient light) .....	426
Diffuse light .....	427
Highlight .....	427
Self-luminous .....	428
Light and material .....	428
<b>Light sources .....</b>	<b>428</b>
General information .....	428
Sunlight .....	429
<b>10 Material .....</b>	<b>430</b>
<b>Introduction .....</b>	<b>430</b>
<b>Materialexplorer .....</b>	<b>430</b>
The content area .....	432
<b>Use materials .....</b>	<b>433</b>
Tap - Transfer .....	433
Assign material .....	433
Search .....	433
Edit .....	434
Scale - Move - Rotate .....	434
Shadow brush .....	434
Background brush .....	434
<b>General settings .....</b>	<b>436</b>
Select material .....	437
Colors/glow lights .....	437
Reflection .....	438
Texture .....	439
Reflection map .....	441
Bumpmap .....	441
<b>11 Video .....</b>	<b>442</b>
<b>12 3D Player Internet object .....</b>	<b>447</b>
<b>Part XIV Terrain .....</b>	<b>450</b>
<b>1 General information .....</b>	<b>450</b>
<b>2 Landscape .....</b>	<b>450</b>
<b>3 Range .....</b>	<b>451</b>
Draw area .....	452
Property dialogues .....	452

<b>4</b>	<b>Property</b>	<b>453</b>
	Draw property	454
	Property dialogs	454
	Embankment	454
<b>5</b>	<b>Terrain shapes</b>	<b>455</b>
	Simple terrain shapes	455
	High point	456
	Ridge	456
	Extended terrain shapes	457
	Overview of terrain shapes	457
	Properties dialog Terrain shape	458
	Drawing extended terrain shapes	459
<b>6</b>	<b>Paths</b>	<b>459</b>
	Draw paths	460
	Property dialogs	461
<b>7</b>	<b>Beete</b>	<b>461</b>
	Input types	461
	Property dialogs	462
	Planting objects	462
	Fitting	463
<b>8</b>	<b>Fences</b>	<b>464</b>
	Draw fences	464
	Property dialogs	465
	Border object	465
<b>9</b>	<b>Terrain modeling (Delaunay triangulation)</b>	<b>466</b>
	General information	466
	Insert geometer data	468
	Settings	471
	Terrain types	474
	Subsequent processing	475
	Representation	476
<b>Part XV</b>	<b>2D views</b>	<b>479</b>
<b>1</b>	<b>Introduction</b>	<b>479</b>
<b>2</b>	<b>Overview</b>	<b>479</b>
<b>3</b>	<b>Free 2D view</b>	<b>480</b>
<b>4</b>	<b>Views</b>	<b>481</b>
<b>5</b>	<b>free view</b>	<b>482</b>
<b>6</b>	<b>Delete 2D view</b>	<b>482</b>
<b>7</b>	<b>Cuts</b>	<b>483</b>
	Create cutting line	483
	Properties of the cutting line	484
	Edit cutting line	485
	Properties of the sections and free views	486
	Create cut	497
<b>8</b>	<b>2D views of the construction (floor plan)</b>	<b>499</b>
	as an unobstructed view with the crumbling floor plan	499
	as a view of the floor plan	500

9	Display of 3D content in 2D views .....	500
10	Further settings .....	501
11	Working in 2D view mode .....	507
	Hide lines .....	508
	Refresh .....	508
	Saving and loading .....	509
	Visible layers and storeys .....	510
	Height dimensioning .....	510
	Export .....	510
12	Scale, paper format and printing .....	512
13	Tips and tricks .....	513
14	Sketch .....	514
15	2D views management .....	515
	View management settings .....	516
<b>Part XVI</b>	<b>2D elements</b> .....	<b>520</b>
1	General information .....	520
2	Lines .....	520
	Input types .....	520
	Property dialogs .....	522
3	Polygon .....	522
	Input types .....	523
	Property dialogs .....	524
	Edit .....	525
	Holes .....	526
4	Circles and arcs .....	527
	Input types .....	527
	Arcs .....	527
	Circles .....	528
	Ellipses .....	528
	Property dialogs .....	528
5	Texts .....	529
	Text input .....	530
	Text rectangle .....	531
	Area composition .....	532
	The parameters in the Area composition dialog .....	532
	Further property dialogs .....	534
	Labels .....	534
6	Auxiliary elements .....	536
	Input types .....	536
	Property dialogs .....	537
7	Pictures .....	537
8	Scanwizard .....	539
<b>Part XVII</b>	<b>Edit</b> .....	<b>540</b>
1	Transfer properties .....	540
2	Editing tools .....	541

Move .....	541
Change Z-height .....	543
Copy .....	544
Routes (S) .....	544
Stretching .....	545
Turning (D) .....	545
Mirroring (I) .....	546
Copy series .....	547
Copy row defined distance .....	547
Copying in the grid .....	547
Copying in a circle .....	547
<b>3 Contour tools .....</b>	<b>548</b>
Edit contours .....	548
Extrude contour .....	548
<b>4 Groups .....</b>	<b>549</b>
Grouping and ungrouping .....	549
Texts in groups .....	550
Component templates and mass determination .....	550
Labeling .....	551
<b>5 Organize .....</b>	<b>553</b>
<b>6 Clipboard .....</b>	<b>554</b>
<b>Part XVIII Trimming tools .....</b>	<b>555</b>
<b>1 L-Trimming (L) .....</b>	<b>555</b>
<b>2 T-Trimming (T) .....</b>	<b>555</b>
<b>3 T-Trimming (multiple) .....</b>	<b>555</b>
<b>4 Extend (G) .....</b>	<b>555</b>
<b>5 Connect .....</b>	<b>556</b>
<b>6 Break open (A) .....</b>	<b>556</b>
<b>7 Break open the roof .....</b>	<b>556</b>
<b>8 Chamfering .....</b>	<b>556</b>
<b>9 Rounding .....</b>	<b>556</b>
<b>Part XIX Dimensioning .....</b>	<b>558</b>
<b>1 Introduction .....</b>	<b>558</b>
<b>2 Property dialogs .....</b>	<b>558</b>
Catalogue .....	558
Layer/Floor .....	559
Size and Position .....	559
Dimension .....	560
Dimensional labeling .....	561
Dimension line .....	562
Dimension guidelines .....	562
Tolerances .....	563
<b>3 Linear dimensioning .....</b>	<b>564</b>
Distance dimensioning .....	564
Wall dimensions .....	565
Drawing .....	566

Change .....	568
Edit .....	569
Line dimensioning .....	572
Dimension arrow for distances .....	572
Multiple dimensioning .....	572
Edit .....	573
<b>4 Circle and arc dimensions .....</b>	<b>573</b>
Measure sheet length .....	573
Radius dimensioning .....	574
Dimension arrow for radii .....	574
Diameter dimension .....	574
Dimension arrow for diameter .....	575
<b>5 Angle dimensioning .....</b>	<b>575</b>
<b>6 Height dimensions .....</b>	<b>575</b>
<b>7 Automatic external dimensioning .....</b>	<b>577</b>
<b>8 Fairs .....</b>	<b>581</b>
<b>Part XX Explorer bar .....</b>	<b>582</b>
<b>1 3D objects .....</b>	<b>582</b>
General information .....	582
Edit .....	584
Substitute representation .....	585
Property dialogs .....	586
Databases .....	587
Insert and move .....	589
<b>2 Symbols .....</b>	<b>591</b>
Insert .....	591
Mirror .....	594
3D designs .....	594
Create and save .....	596
Databases .....	597
<b>Index .....</b>	<b>600</b>

# 1 Introduction

Plan7Architect is a software that focuses on integrated, end-to-end three-dimensional planning. From the project idea to design and execution, Plan7Architect covers the entire planning process. In addition, it meets the new entrepreneurial challenges that construction professionals are facing: Planning security, comprehensive advice, involvement of all those involved in the construction project and visual communication.

Plan7Architect with its extensive functions is used for the individual planning of new buildings, from carports to industrial complexes, as well as for planning services relating to existing buildings: Conversions and extensions, refurbishments, etc.

Operation is clearly structured and presented in an appealing design. The clear interface guides the user optimally through the work processes. Self-explanatory symbols make it easy to use. The program's intuitive navigation provides immediate access to the most important parameters. Only when required does the user delve deeper into the operation and can use the many special functions. The extremely simple operating concept of Plan7Architect guarantees a quick start to the program.

The 3D building model is the basic for efficient and consistent work. It is made up of "intelligent" components (walls, windows, stairs, doors, etc.) with their parameters and properties corresponding to reality.

The component-oriented working method enables precise, true-to-scale and detailed design and provides planning reliability.

Positioning and dimensioning of a component can be carried out without time-consuming coordinate input. The relevant dimensions are displayed interactively for each component type during processing. By clicking on a dimension, it is activated and the user can determine and change the position and size of the component.

The change to the component parameters is immediately shown in the model and a direct check, e.g. for collisions with other components, is therefore guaranteed.

All necessary data can be derived from the 3D building model: sections, views, details, necessary building documents for planning permission, drawings and data for execution planning.

Using the 2D functions, the automatically generated plans can be quickly and easily edited, supplemented and prepared for further specialist planning.

Construction details and additions are displayed using 2D graphic elements with line types, hatching and fillings in line with the building plans.

The level of detail of the components is impressive. The walls are not only multi-layered, but also offer the option of a timber construction, as do the ceiling and roof.

Plan7Architect has an automatic scale-dependent display. Depending on the selected scale, the level of detail of the drawing is refined and enables the correct representation during the transition from the preliminary draft to the approval plan to the detailed drawing.

The visualization also draws on the 3D building model. It plays a particularly important role in Plan7Architect, as an emotionally appealing three-dimensional representation of the planning object often contributes to the purchase decision today.

Thanks to the newly developed visualization concept, waiting for high-quality images due to long computing times is a thing of the past. Real-time visualization with lights, reflections and anti-aliasing is the solution. The quality of the Plan7Architect visualization is comparable to the results of specialized rendering software, but in real time and without the need for any prior knowledge on the part of the user. To speed up visualization, simplified structures are calculated for complex 3D objects insofar as the reduced details are not visible to the viewer (level of detail for 3D objects). This means that very realistically designed projects, including entire settlements, can be efficiently displayed and edited.

A highlight of the visualization are the projective textures. This is a new technology that makes it possible to merge virtual models with real images in the simplest possible way. The user can combine the photographed existing building with the design planning and thus convincingly demonstrate the combination of old and new in a photorealistic way.

Plan7Architect includes the c3D-Player for the three-dimensional visualization of the created buildings. It is used, for example, to present architectural projects on the Internet - certainly a way for architects, estate agents or property developers to stand out from the competition in the future. The user can position plan sections with different scales in Plan7Architect for plan compilation. Changes in the project are automatically transferred, title blocks and legends can be created. Similar to the component templates, plan templates can be individually defined for the creation of presentation documents and exposes.

## 1.1 Version note

Due to the fact that there are different versions of the program and Plan7Architect, CASCADOS, FFR, ArCon BIM, 3D Architect and E-CAD are based on the same program principles/program, there may be slight differences between your version and the manual.

## 1.2 Hardware and software requirements

For desktop and notebook PCs

### System requirements

#### Requirements for a workstation

(for desktop and notebook PCs with Plan7Architect )

Hardware requirements	Minimum requirements	Minimum recommendations
RAM	4096	8192
DVD	4x	48x
Hard disk	40GB	400GB
External hard disk capacity	5GB	20GB

Graphics cards (more info below)	AMD/ATI or Nvidia based graphic card (GPU)	NVIDIA GeForce 1070 or 1080
Monitor	17" (15" laptops)	24" (desktops)
Color depth	16 bits	32 bits
Resolution	1024x768	1920x1080 or higher
Printer	-	Color inkjet or Color laser
CPU	Pentium Dual-Core	Intel® Core® i7 AMD FX
Operating system	Windows 10	Windows 10 Professional 64bit / Windows 10 Enterprise 64 bit

Attention! Apple Mac is not supported.

Before purchasing new hardware, you should clarify the following general questions with your hardware supplier:

- Suitable procedures and media for creating back-up backups (e.g. via an additional hard disk, network/server backup, CD-ROM, memory stick or similar)
- Options for dual video output, e.g. for the use of 2 monitors
- If photorealism is your focus, it is very important to choose a particularly powerful processor. In this case, a high-end Intel® Xeon® E5 CPU would be preferable to an Intel® Core i7, for example.

## Graphic cards

(for desktop and notebook PCs with Winner Design)

To make the most of all the possibilities offered by the high-quality CAD interface of Plan7Architect, you need to use good graphics hardware. Using the right graphics card can save you problems and offers you the highest guarantee for achieving the best work results.

### Firstinvision has tested many graphics cards and recommends the following:

Nvidia and AMD produce graphics chips that are used by quite a few graphics cards manufacturers (Asus, MSI, Gigabyte, Club 3D, Sapphire, LeadTek, etc.). Graphics cards based on graphics chips from AMD and Nvidia are sold under different names.

The most important thing is that the card is based on the named standards from Nvidia or AMD.

**The following graphics cards are not recommended for use:**

- Matrox cards (all types)
- Quadro graphics cards
- ATI Rage Pro, All-In-Wonder Pro, Expert@Play98, Expert98
- S3 GammaChrome
- SIS cards (ordinary SIS cards and motherboard integrated cards)
- XGI Volari
- Older Intel® graphics cards (Intel HD Graphics 4600 and previous versions). Newer Intel® graphics cards usually work, but perform slower than NVIDIA or AMD based graphics cards.

By following our recommendations, you can avoid performance problems when using Plan7Architect. Don't let your hardware supplier's recommendations to the contrary persuade you in this regard, but insist on a GeForce or Radeon-based card.

## 2 Licensing

After you have installed Plan7Architect, you must now license it before you can put it into operation. When you open Plan7Architect for the first time, the licensing window will open which you can activate or deactivate your license (if Plan7Architect has already been licensed) or test the program for 30 days without a license.

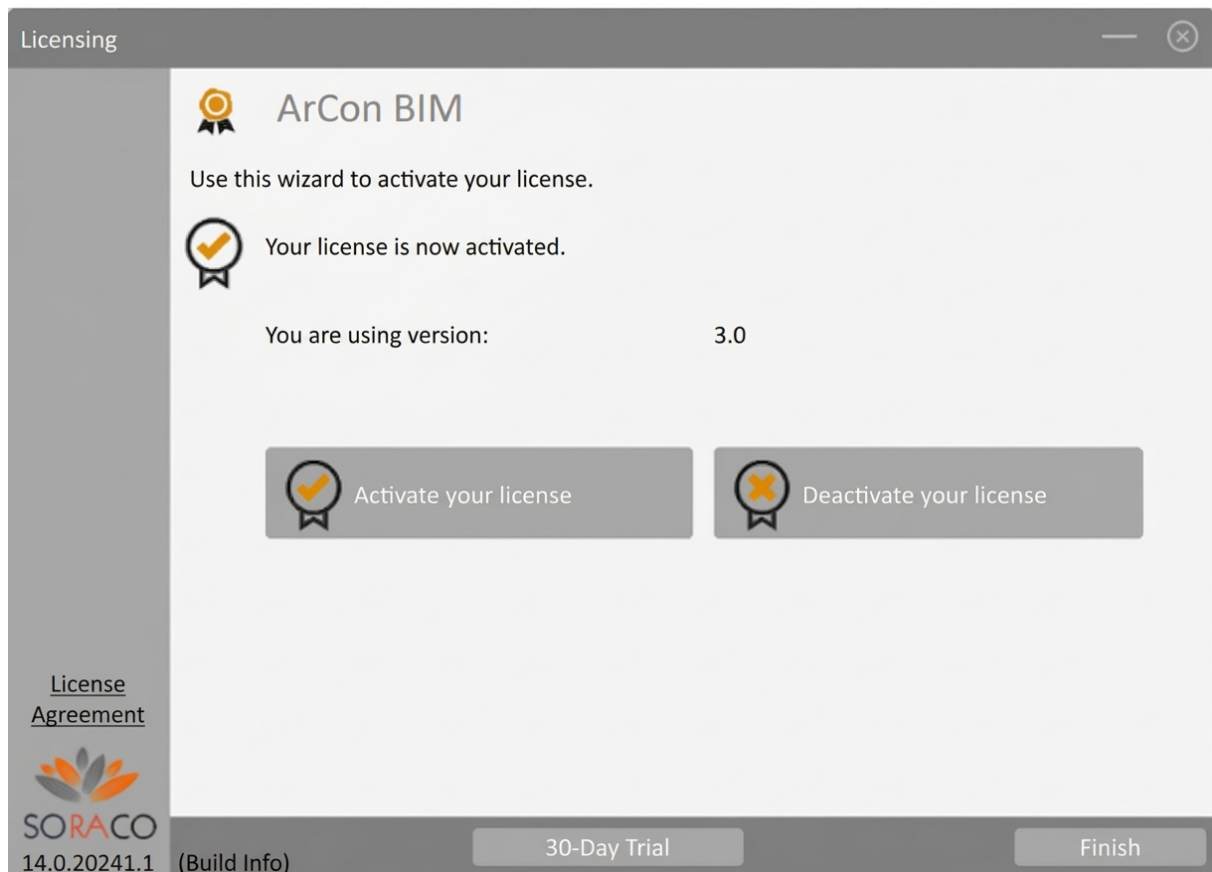

To activate your license, please go to "Activate your license", select "Activate online" and enter your license key.

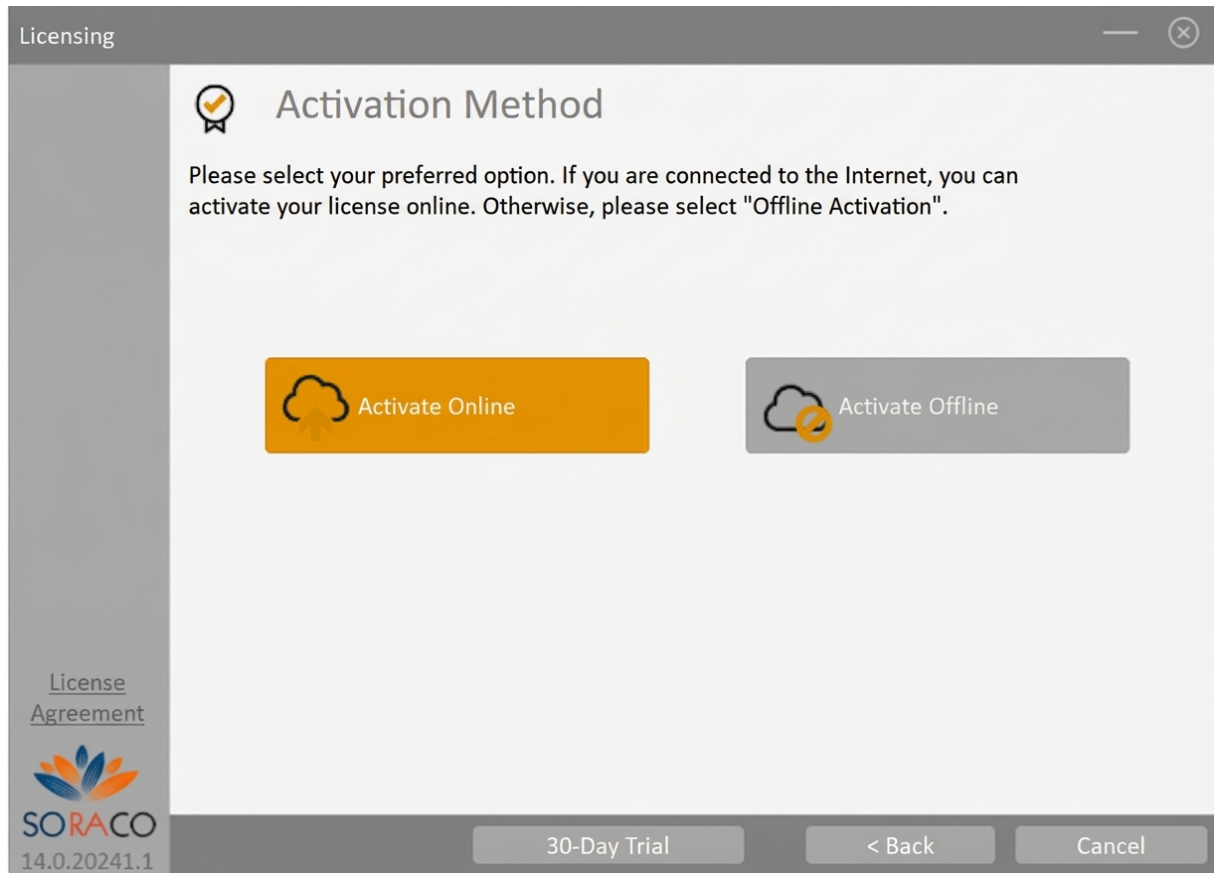

After you have entered your license key, please click on Activate license key to license Plan7Architect. After you have successfully licensed Plan7Architect, please click on "Finish".

Licensing

## Online Activation

Enter your license key and click on "Activate". A connection to the license server will be established and your license will be activated. If you do not have a license key, please enter your email address.

License key

 Your license is now activated.

[License Agreement](#)

  
SORACO  
14.0.20241.1

### 3 Application menu - File management (load/save/save)

You can access the file management via the button **FILE** in the top left-hand corner of the screen.

In this menu you will find all the commands for opening, saving and creating a new file as well as for importing and exporting.

**File|New:** A new project is created. The **Standard.cad** file in the **Templates** directory, if available, is used as the template. If this file does not exist, the new project is created with the program's standards.

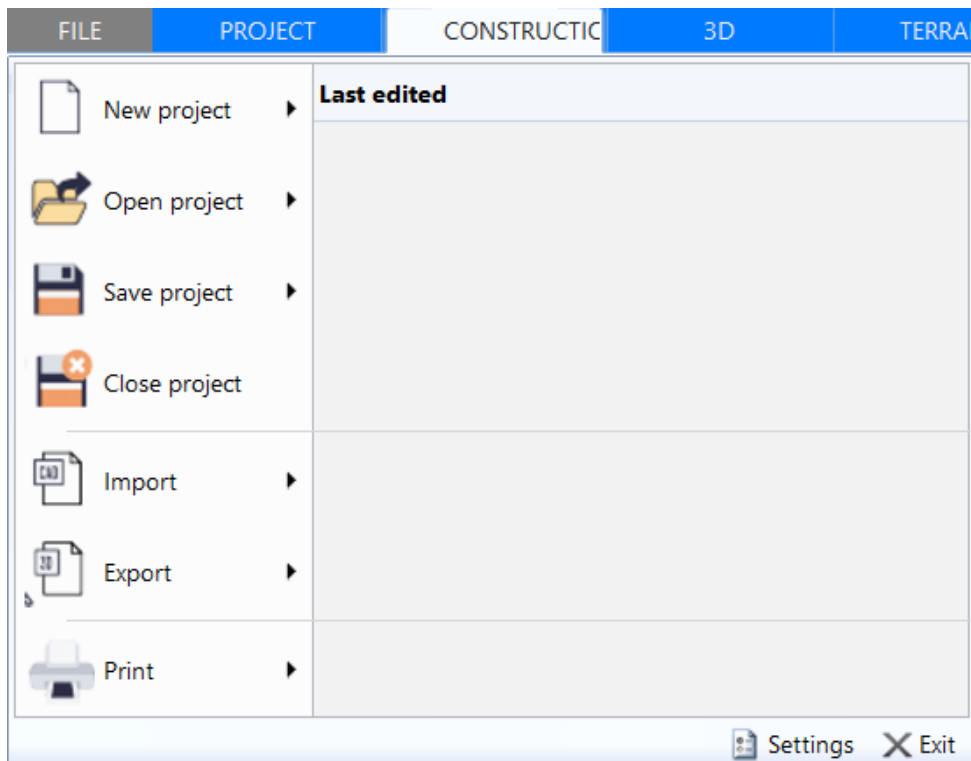

**File|New with template...:** A new project is created based on a template drawing. A template drawing is a normal project file in which the desired default settings are made. When creating a project based on a template, this file is copied and used as a new project. Typical default settings are, for example, the layer structure or storeys.

**File|Open:** This function is used to open project files. The standard format for project files is .CAD. The following file formats can also be opened:

- ACSII files: Standard for text files
- DXF files: Standard for the exchange of vector data from Autodesk
- DWG files: standard format from Autocad/Autodesk
- Graphic Works 4.0 files: Standard for importing Graphic Works CAD files (Data Becker)
- IFC files: 3D standard format from Autocad/Autodesk
- EMF files: Enhanced Meta File; for data exchange between Windows applications
- WMF files: Windows Metafile Format; for data exchange under Windows applications

- MB exchange format files: Standard format for AutoDesk Maya binary files

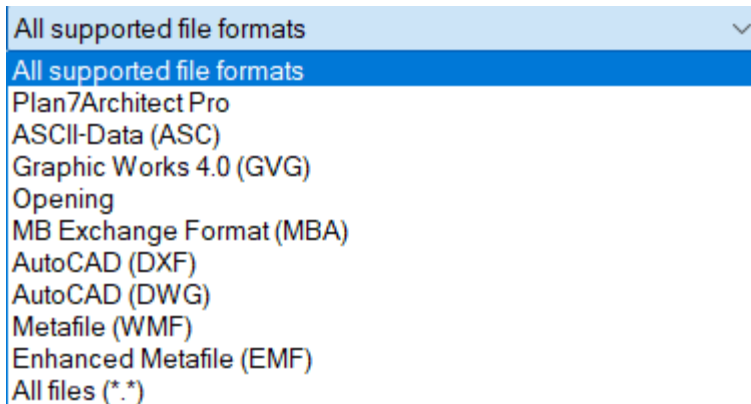

**File|Search:** This function is used to search for project files.

The "Search project" search screen opens:

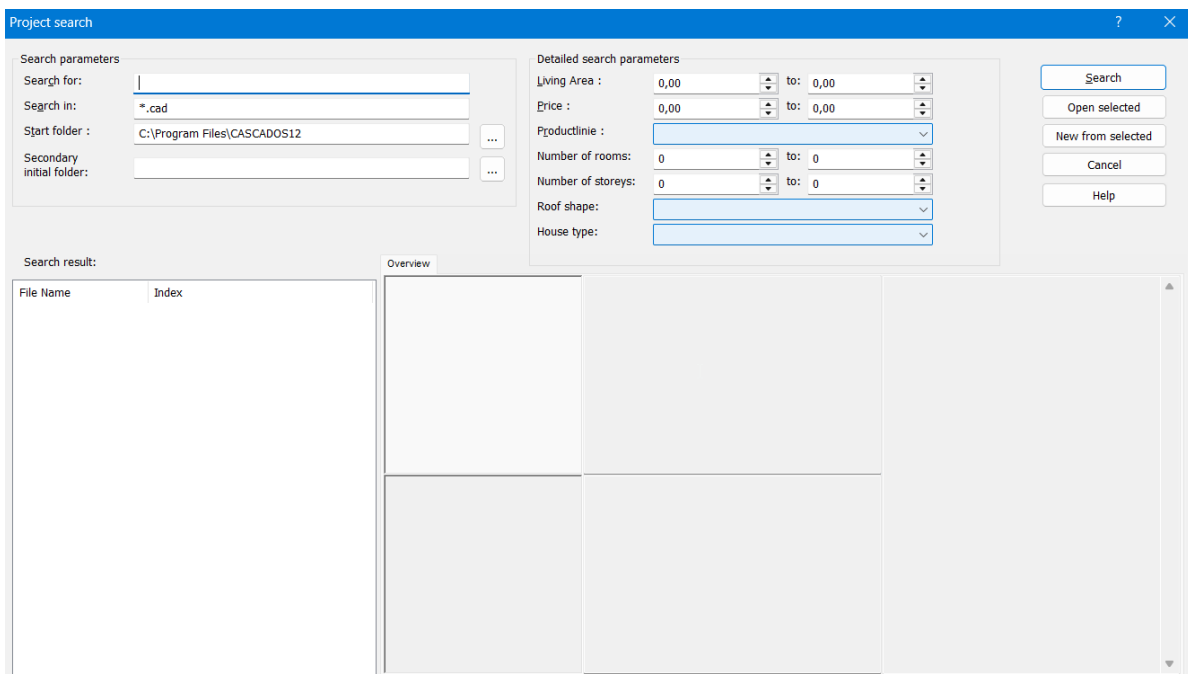

**File|Open from clipboard:** Opens a project that has been copied to the clipboard.

**File|Open last project:** Opens the last saved project.

**File|Save:** This function is used to save the file opened on the screen.

**File|Save as:** Saves the file and opens the file manager beforehand; you can now assign a file name here.

### 3.1 Useful information for experienced users

We have revised the entire user interface with the latest version of Plan7Architect. We would like to give you a brief overview of the most important changes in the following text.

#### Ribbon interface

Ribbon means ribbon and is a graphical operating concept for application programs.

#### Modes and tools

The upper menus now provide the modes and the function bars for the drawing tools

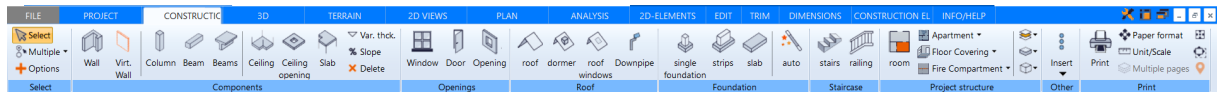

The modes range from construction to plans, and the function bars are available from evaluation to construction level.

You can therefore change the mode by selecting the relevant tab or simply display a suitable tool palette.

#### Project ribbon

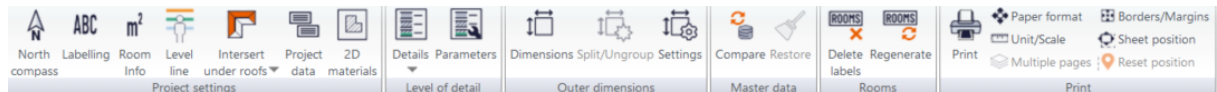

This function bar was the Project menu in the previous Plan7Architect version.

Of course, we have also added some other buttons.

You can make all project-relevant settings in this toolbar, regardless of which mode you are currently in.

#### View

In previous versions of Plan7Architect, the options that determine what is currently visible or not were accessible both via a toolbar and via a 'View' menu.

Now we have combined all these functions in all modes in the toolbar view bar. Note in particular the last button for the advanced view settings.



#### Options

The Options menu can now be found in this button at the top right of the screen.

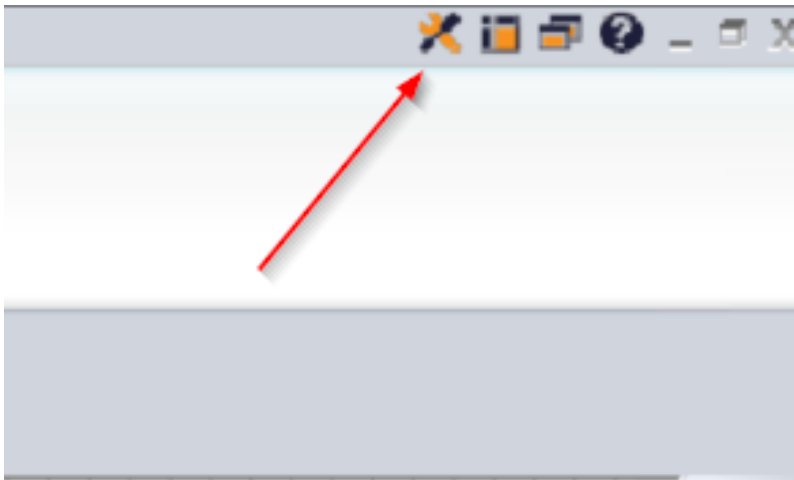

### File management

All commands for loading, saving, importing and exporting files as well as all settings can be found in the new File menu.

### Designing the user interface

With the new version, you can move the toolbar to any desired position. The program is therefore much better able to adapt to your individual ergonomic work interface. As shown in the picture below, you can see all toolbars in undocked state.

You can close each bar by clicking on the X in the top right-hand corner.

To show the toolbar again, please use the View button at the top right of the screen

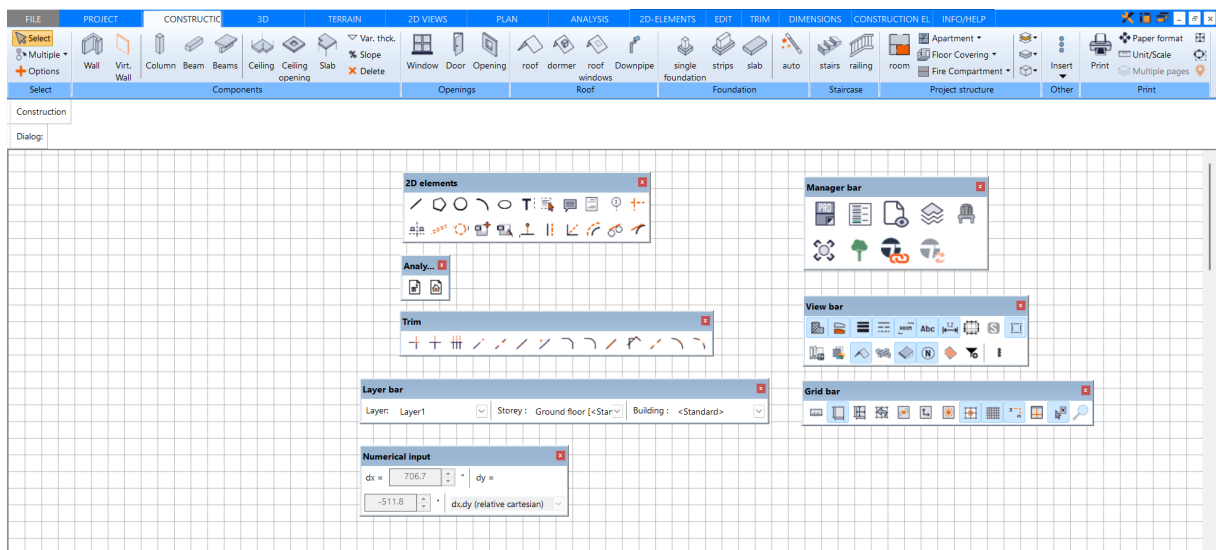

### Manager bar

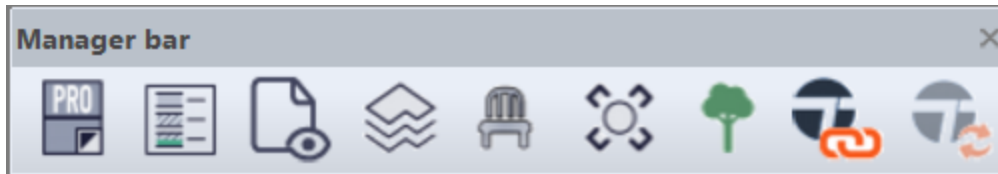

These buttons were also listed in the same order in previous versions. What is new is that this bar can now also be moved freely around the screen, ideally to a second monitor. The corresponding dialogs then open near the bar on a second screen.

## 3.2 Import/Export

All information on importing and exporting a wide range of formats.

### 3.2.1 IFC interface

#### The IFC file format

Basic information: If you receive a project from another office (e.g. an AutoCAD file) which contains component information and which is imported via the IFC interface, it is important to check the geometry during import and, if necessary, to add new components of your own.

External viewers are available for checking in 3D, e.g. the Solibri Model Viewer (freeware, free of charge). This makes it very easy to compare 3D information.

The **Ignore geometry** option in the Plan7Architect catalog also provides assistance when reworking and changing the components; this allows wall types without wall thickness to be assigned and only the master data changes in the geometry of the project, but not the geometry itself.

Typical sources of error when importing IFC are sensitive components such as roof structures and rooms. It can be assumed that around 80% of an average IFC model can be used and that around 20% still needs to be reworked.

However, the possibilities for a smooth IFC import will be continuously improved in the future.

The IFC data format contains two different levels of complexity:

- Pure representation of components in an IFC viewer: Here, surfaces are simply read in and displayed.
- Interpretation of metadata linked to components: This is done by Plan7Architect. An evaluation of metadata is essential for zoning and mass determination, for example. The following procedure is therefore essential here: Reading/Importing the IFC data, post-processing the model and comparing whether the data is correct with the original model using a viewer (e.g. Solibri).

The abbreviation IFC stands for Industry Foundation Classes and is a neutral file format for the exchange of information, in particular the 3-dimensional building model, between different CAD solutions in the construction industry.

The format is developed by the IAI, the International Alliance for Interoperability. Further information can be found at: [www.buildingsmart.de](http://www.buildingsmart.de)

With this user-friendly interface, IFC enables the user to communicate efficiently with other project participants and helps to identify any errors.

The version described in this manual is IFC 2X3

### IFC file types

ifc: the normal, uncompressed file format

ifcxml: creates an XML database for all programs that cannot read the IFC format. (e.g. calculations, energy calculations, etc.)

ifczip: a compressed version of the normal IFC format

### Element classification

Wall	ifcWallStandard
Door	ifcDoor
Window	ifcWindow
Opening	ifcOpening
Joist	ifcJoist
Beam	ifcBeam
Support	ifcSupport
Room	ifcRoom
Ceiling	ifcCeiling
Roof	into individual ifcroof areas
Roof window	ifcRoof window
Slab	ifcSlab
3D object	ifcFurniture
2D elements	
Line	is not read
Arc	is not read
Ellipse	is not read
Text	is not read
Dimension	is not read

#### 3.2.1.1 Import General

IFC import formats are IFC 2x3 and IFC 4.

Currently only IFC text files ("Plain Format") are supported, IFC XML files cannot be imported.

##### 3.2.1.1.1 General information on importing

Recommendations for import:

Construct buildings as close as possible to the 0-point.

Export elements with parameters (width, height,...)

Walls can contain layered structures

A building should contain at least one storey

#### Units:

Length unit IFCSIUnit, default is meter

Angular unit IFCConversionBasedUnit, default is radians

#### 3.2.1.1.1.1 Site building storeys

##### **Site**

IFCSite is not imported

##### **Building**

IfcBuilding

The following properties are used: Name, Description, GlobalID  
In Plan7Architect the building has no height, the value is set to 0

##### **Storey**

IFCBuildingstorey

The following properties are used: Name, Description, GlobalID, Height

#### 3.2.1.1.1.2 Walls

##### **Walls**

IFC class: IfcWall, IfcWallStandardcase

During import, the heights of the imported wall are adopted, but depending on the height, they are referred to the height levels of the storey as usual in Plan7Architect.  
height levels of the storey.

The lower and upper edges of the wall are always horizontal.  
Wall layers are also imported when a wall is created.

Importing an IFC wall creates a wall, a polygonal wall or a 3D object.  
What is created depends on the geometry of the IFC element.  
A standard wall is created if the IFC geometry has a rectangular contour, otherwise the polygonal contour is determined by a section in order to draw the polygonal wall.

#### 3.2.1.1.1.3 Rooms

Ifc class: IFCSpace

Once the wall import has been completed, an initial recognition of spaces is carried out.  
If the IFC file contains IFCSpace elements, a closed contour is searched for in the wall contours for each IFCSpace.

The room name is adopted  
The levels are taken from the polygon

Representation

IfcExtrudedAreaSolid

Each room is assigned to a storey  
Each room is assigned to a layer

#### 3.2.1.1.1.4 Windows - Doors

Concerns windows, doors and openings  
IfcClass: IfcOpeningElement, IfcDoor, IfcWindow  
These elements must be part of IfcOpeningElement.  
Windows and doors are only read in when placed in walls.

##### Representation

SweptSolid, IfcExtrudedAreaSolid, IfcCircleProfileDef

The representation of IfcOpeningElement can be specified with or without SweptSolid.

If no SweptSolid is used, the oriented bounding box of the 3D geometry is used.

The SweptSolid representation must have the following properties in order to be used:

- one or more elements of IfcExtrudedAreaSolid;
- each element of IfcExtrudedAreaSolid must have a SweptArea of type IfcCircleProfileDef or another type, from which a closed polygon can be retrieved;

#### 3.2.1.1.1.5 Roof

IfcClass: IfcRoof, IfcSlab with ROOF as PredefinedType

##### Layer

If no layer is defined for the imported roof, the element is stored on the "Roofs" layer

##### Representation

Body, IfcExtrudedAreaSolid, IfcManifoldSolidBrep, IfcFaceOuterBound

The representation must be a body representation and can have more than one element. The elements of the representation must be: IfcExtrudedAreaSolid, IfcManifoldSolidBrep. In the case of IfcManifoldSolidBrep, only the points of IfcFaceOuterBound are used.

#### 3.2.1.1.1.6 Blankets

IFC class: IfcSlab

##### Representation

The representation must be a solid representation and can contain several elements.

A slab is created for each IfcExtrudedAreaSolid element. The slope must be 0, otherwise a 3D object is created. The thickness is defined via IfcExtrudedAreaSolid::Depth. Ceiling openings are IfcOpeningElement and must be specified in IfcElement::HasOpenings.

#### 3.2.1.1.1.7 Supports

IFC class: IfcColumn

##### Representation

The representation can be specified with or without SweptSolid.

If no SweptSolid is used or unsupported parameters are used, the column parameters are derived using the 2D oriented bounding box. If the SweptSolid is used, it must contain a vertical IfcExtrudedAreaSolid.

Depending on the type of `IfcExtrudedAreaSolid::SweptArea`, the resulting column will look as follows:  
 -a standard column, if the `IfcExtrudedAreaSolid::SweptArea` is a type of `IfcParameterizedProfileDef` of these types: `IfcCircleProfileDef`, `IfcEllipseProfileDef`, `IfcRectangleProfileDef`. For `IfcCircleProfileDef`, `IfcEllipseProfileDef` the type of the column is "round" (Pillar), for `IfcRectangleProfileDef` it is "square" (Support). The 2D-oriented bounding box is used for other types;  
 -a spline column if the `IfcExtrudedAreaSolid::SweptArea` is not an `IfcParameterizedProfileDef`.

#### 3.2.1.1.1.8 Beams

## 1 Beam, Girder

IFC class: `IfcBeam`, `IfcFooting`

### Representation

The representation can be specified with or without `SweptSolid/Clipping`.

If no `SweptSolid/Clipping` is used or unsupported parameters are used, the parameters are derived using the oriented bounding box. If `SweptSolid/Clipping` is used, it must contain an `IfcExtrudedAreaSolid`.

Depending on the type of `IfcExtrudedAreaSolid::SweptArea`, the resulting beam has the following profile type: - "round" if the `IfcExtrudedAreaSolid::SweptArea` is an `IfcCircleProfileDef`, `IfcEllipseProfileDef`; - "rectangular" if the `IfcExtrudedAreaSolid::SweptArea` is an `IfcRectangleProfileDef`;

Depending on the x/z directions, the building element is imported as a beam or as a girder. For beams, miter is imported if the clipping representation is used.

#### 3.2.1.1.1.9 3D-Objekte

IfcClass: `IfcStair`, `IfcFurnishingElement`, `IfcBuildingElementProxys`, `IfcRailing`, `IfcIfcProductObject3D`, `IfcBuildingElementPart`, `IfcCovering`, `IfcCurtainWall`

All the element classes listed above are read in as 3D objects.

#### 3.2.1.1.1.10 cannot be read in

IfcClass:`IfcChimney`  
 Fireplaces and chimneys

IfcClass:`IfcGrid`  
 Grid

all 2D elements

### 3.2.1.2 Import IFC file

IFC files can be opened via the menu item **File|Open|Project...** as well as via the menu item **File|Import|IFC...** menu item:

For example, a 3D model from another CAD system (which supports IFC) can be imported using the **File|Open...** command:

Now select the IDC file for the import.

The dialog for the import opens:

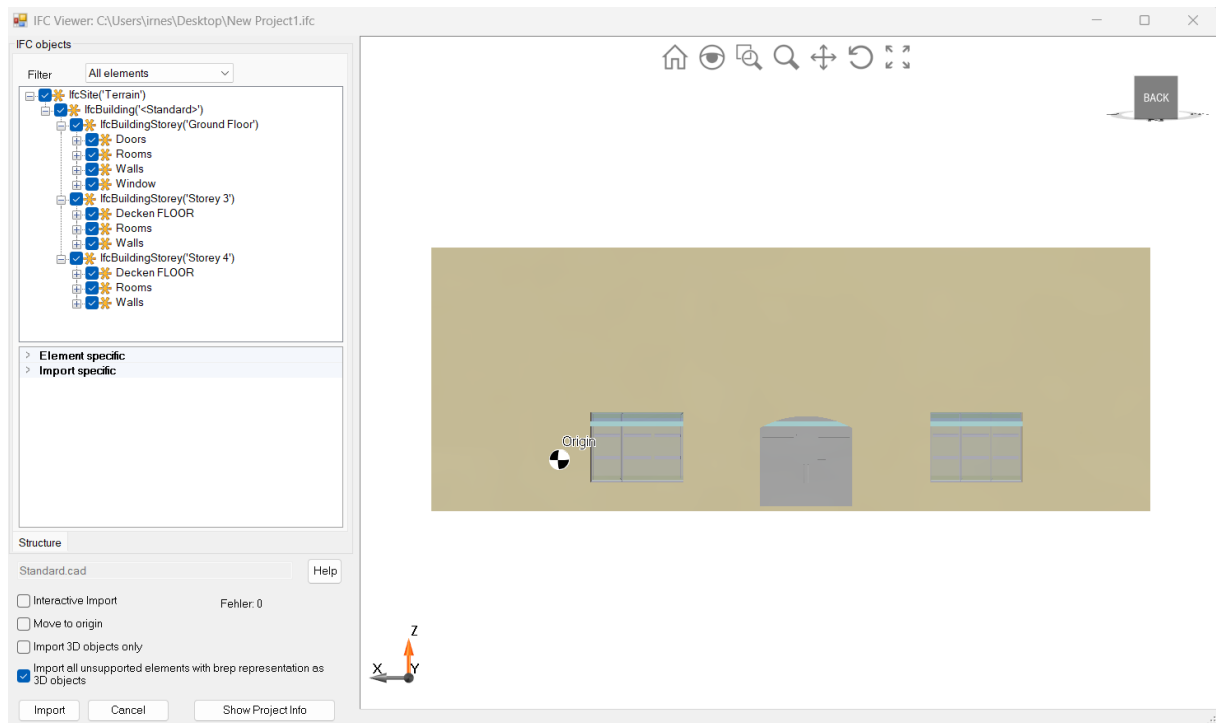

IFC elements can be selected in the component explorer on the left-hand side of the dialog; these are marked in the 3D window.

Elements can also be selected in the 3D window; these are then marked in the component explorer.

The visibility of elements can be selected using the option boxes in the explorer. This option also controls whether an element is imported into the planning.

If an element is selected, the IFC type is displayed below the 3D window. Information on the GlobalID and the predefined type is also displayed

<b>Element specific</b>	
Global ID	
IFC element type	
Layer	
Predefined type	
<b>Import specific</b>	
CASCADOS type	
Detailed import errors	
import error	

Import errors for the element are listed in the Import-specific section.

### Move to the origin

The elements are moved to the origin during import. Recommended in any case.

**Only import 3D objects**

The elements are not imported as components, but as 3D objects.

**Import errors**

IFC elements cannot always be imported correctly. If this is the case, a list of the problems encountered is displayed in the Import errors section after the import.

Elements that cannot be imported correctly are displayed with a substitute display in the "Import errors" layer set.

**Show project info**

Opens a dialog with information about the IFC file such as software version, manufacturer, project name, etc.

**3.2.1.3 Export IFC file**

An IFC file can be exported from any mode:

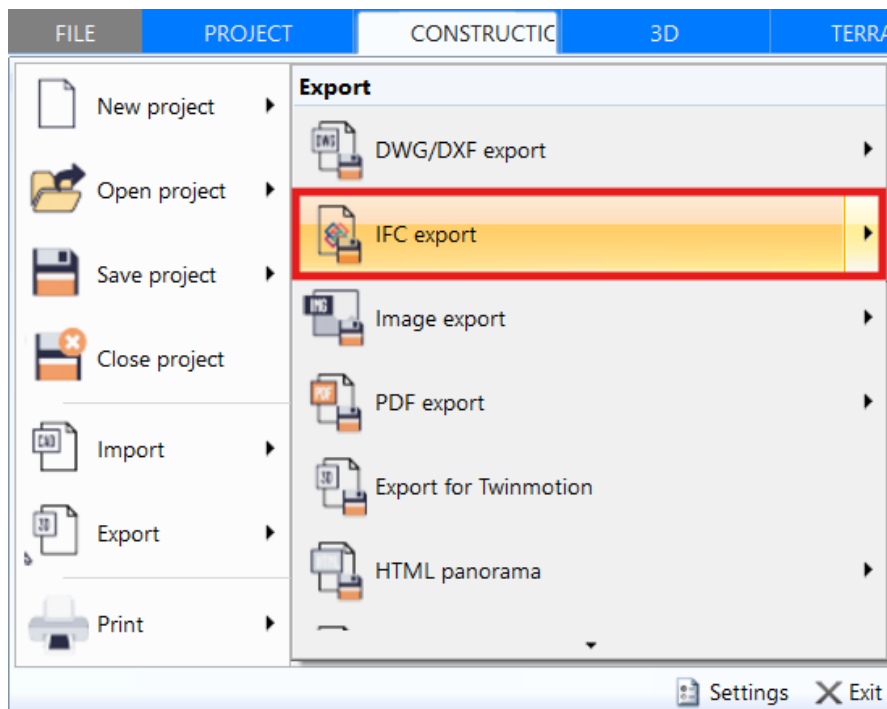

The settings for the components are made here:

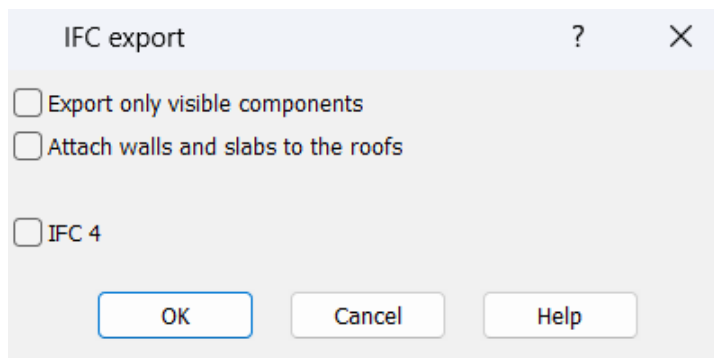

Export only visible components: Only visible elements are exported with the IFC file  
Clip walls and ceilings to roofs:  
Only display this dialog when the Shift key is pressed:

The IFC file is saved in the file explorer after export:

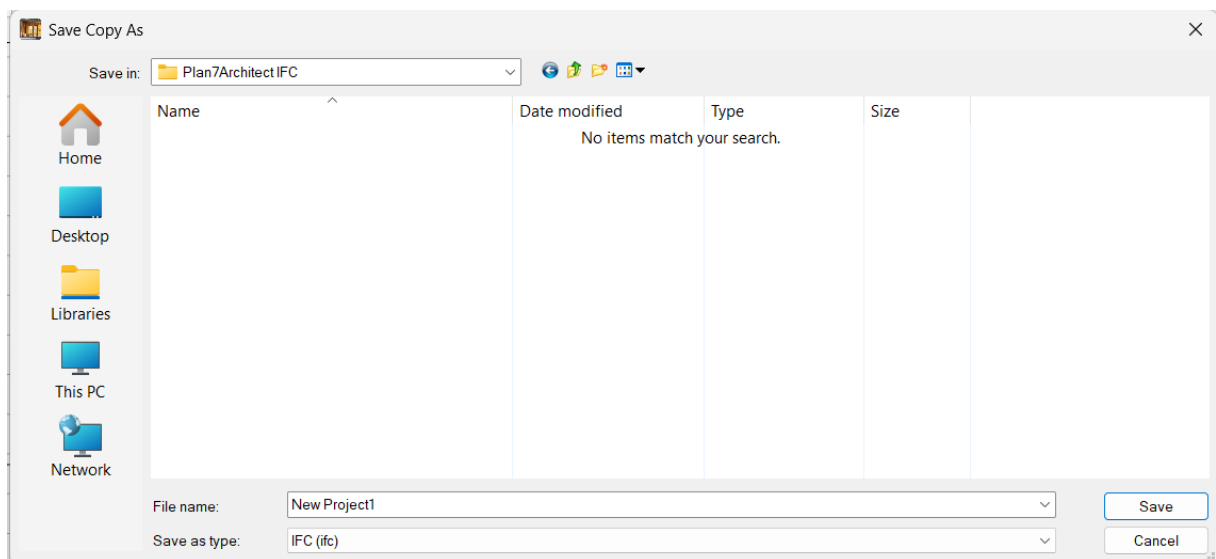

Under **File type**, you can also specify the format in which the IFC file is to be saved (ifc, ifc.XML, ifc.ZIP: Further information under: [IFC interface](#)<sup>[28]</sup>).

### 3.2.2 DWG/DXF

Regardless of whether the DXF/DWG file has been opened (**File|Open**) or imported (**File|Import|Project file**), an import dialog appears after selecting the file.

All **import parameters** can be defined in this dialog before the actual import into the software (in the **General/Selection area/Layers/Colours/Line styles** tabs):

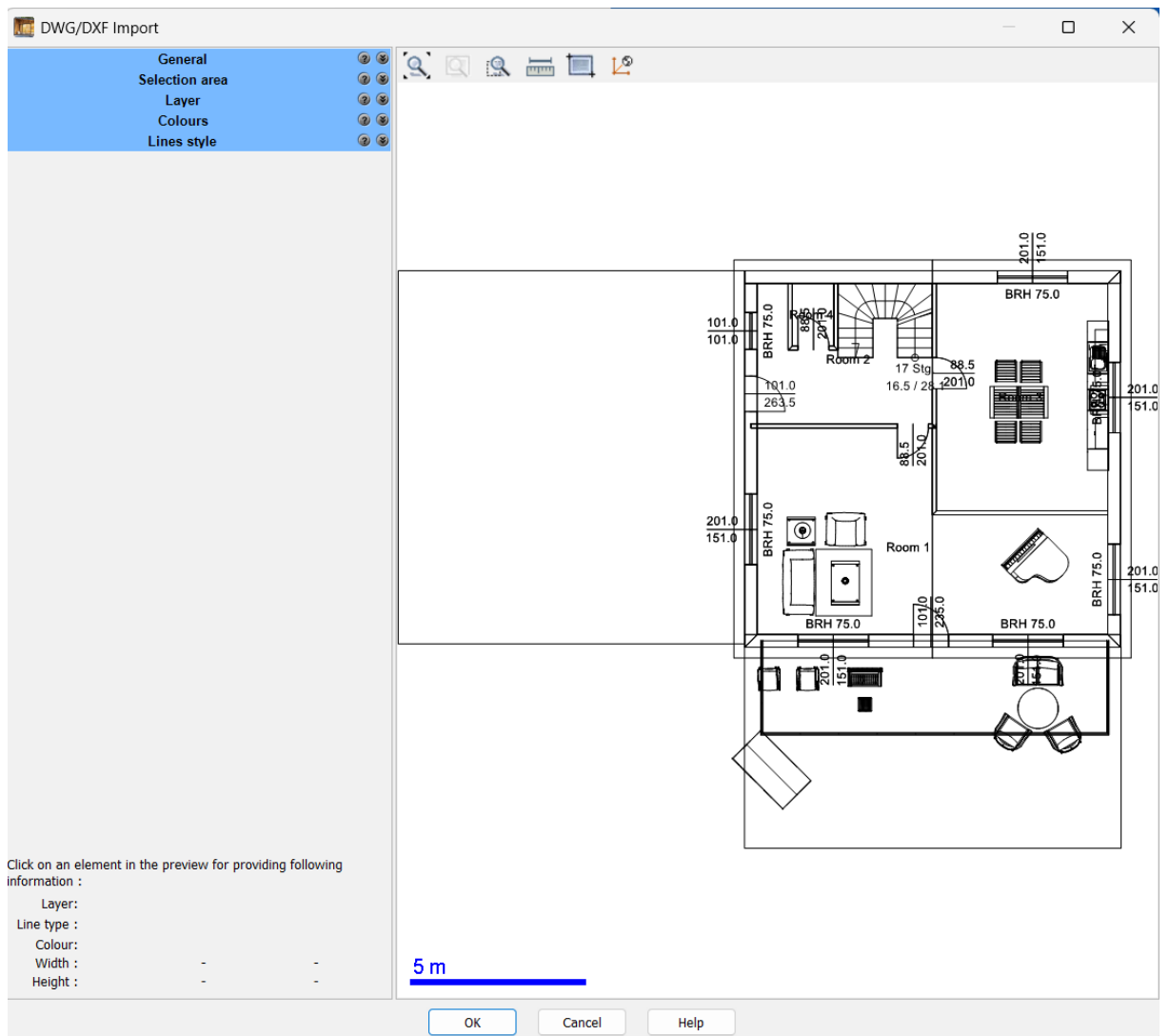

We recommend that you reduce DXF/DWG files to the required elements before importing them into . These include, among others:

- Building floor plan or parts thereof
- Structural features (e.g. doors/gates/windows/stairs)

### 3.2.2.1 Define the drawing unit

DXF/DWG files use so-called drawing units. Unfortunately, it is not possible to automatically determine during import whether a drawing unit corresponds to a meter, a millimetre or possibly even an inch. You must specify this during import. The following options and tools are available for this purpose and can be found under the **General** tab:

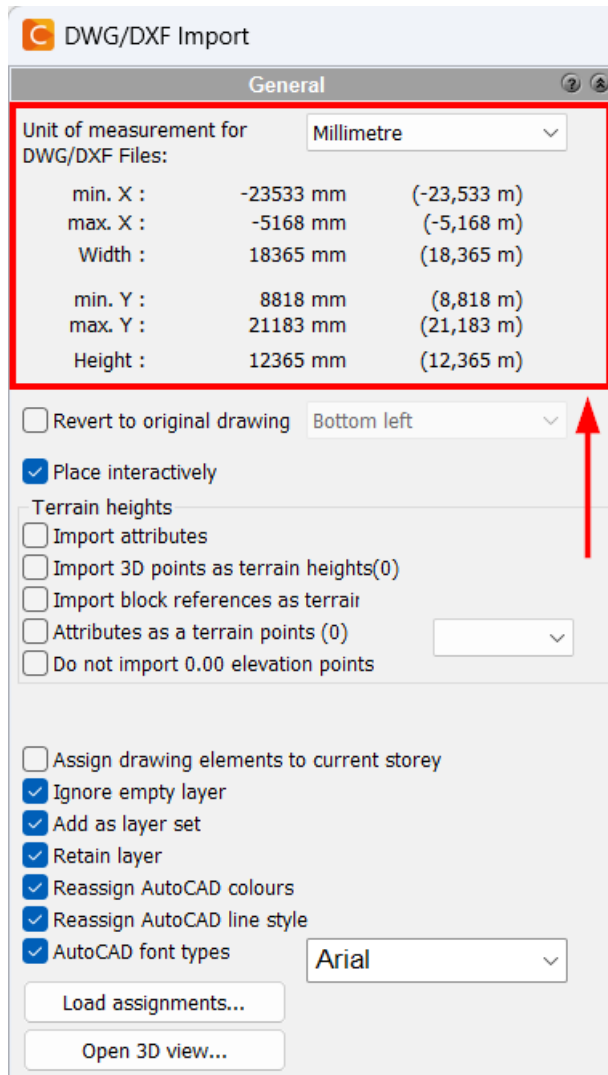

The **Unit** selection box:

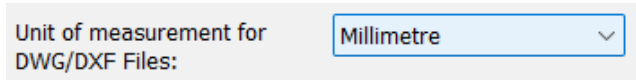

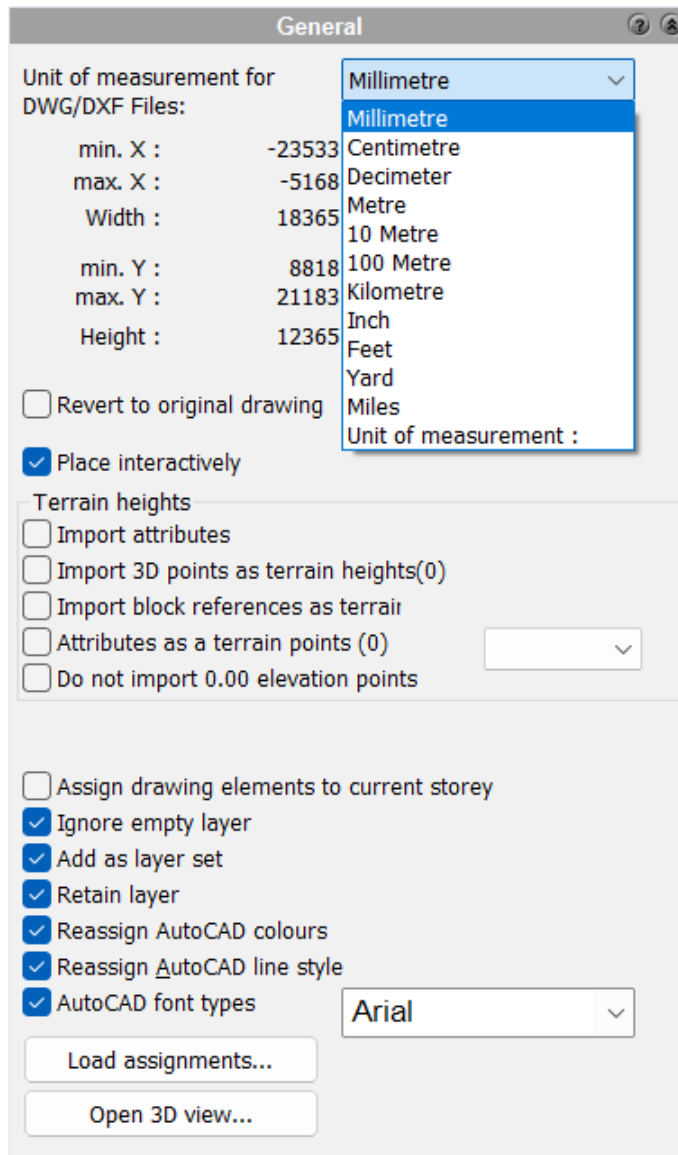

In addition to the length units of meters, centimeters, etc., you can also enter a factor in addition to the length unit by selecting ...Unit. This is necessary if the file contains a plan at a scale of 1:200, for example.

### Assistance in defining the drawing unit:

#### 1. length scale

The unit used can be defined directly. A length scale is displayed at the bottom of the preview window to make it easier to determine whether the selected unit is correct.

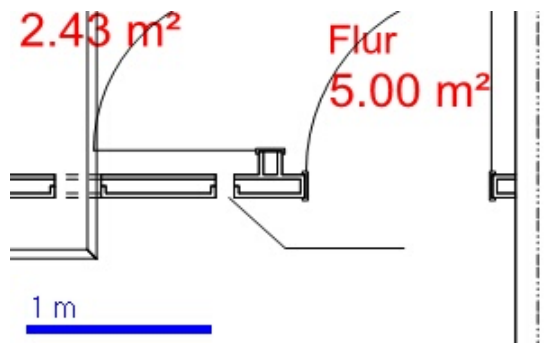

You can easily compare the length scale with known dimensions, e.g. with the width of a door. This makes it easy to check that the drawing unit has been defined correctly.

2. measure distance 

The command can be started in the toolbar above the preview window.

Use the mouse wheel to zoom to a point with a known distance.  
Click on two points, then a dialog opens with the length between the two points.  
Change the unit if the specified distance is not correct.

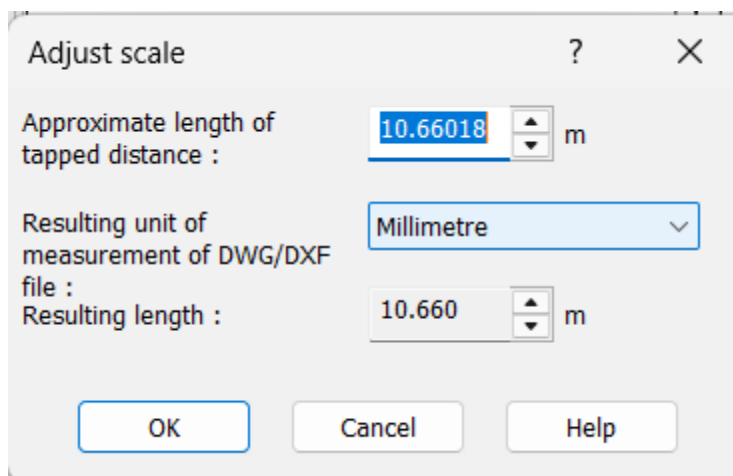

### 3.2.2.2 Terrain import

**Import terrain points via DXF/DWG ( *General* tab ):**

Einheit der DWG/DXF Dateien :

min. X :	122 mm	(0,122 m)
max. X :	148 mm	(0,148 m)
Breite :	26 mm	(0,026 m)
min. Y :	162 mm	(0,162 m)
max. Y :	179 mm	(0,179 m)
Höhe :	16 mm	(0,016 m)

Zeichnung in den Ursprung verschieben

Interaktiv platzieren

Attribute importieren

Punkte als Geländehöhen importieren

Blockreferenzen als Geländehöhen importieren

Zeichenelemente einem Geschoss zuordnen

leere Layer ignorieren

als Layersatz einfügen

Layer beibehalten

AutoCAD Farben zuordnen

AutoCAD Linienstile zuordnen

AutoCAD Schriftart

You can import **points** (CAD element Point) as terrain **heights** or **block references as terrain heights**. First check which type is contained in the DXF/DWG file and whether z-coordinates are actually specified.

When using block references, it is a great advantage if all other blocks are not imported. (possibly in a second import process) These blocks would also be interpreted as elevation points.

### 3.2.2.3 Open or import

You have the option of **importing** or **opening** DXF/DWG files. The import command can be found in the pull-down menu under **File|Import|Project file...**

**Import** inserts the drawing elements into the currently open project. You can choose whether the drawing elements are grouped together on a layer (the active layer in the project) or transferred with the layer structure of the imported file.

When you **open** a DXF/DWG file, you always receive the layer structure of the file. You will find the command in the pull-down menu under **File|Open...**

The advantage of the method of opening a file is that error corrections, changes, deletion of superfluous elements etc. are carried out **separately from the actual project file**, thus avoiding errors.

If necessary, select the file format for the import:

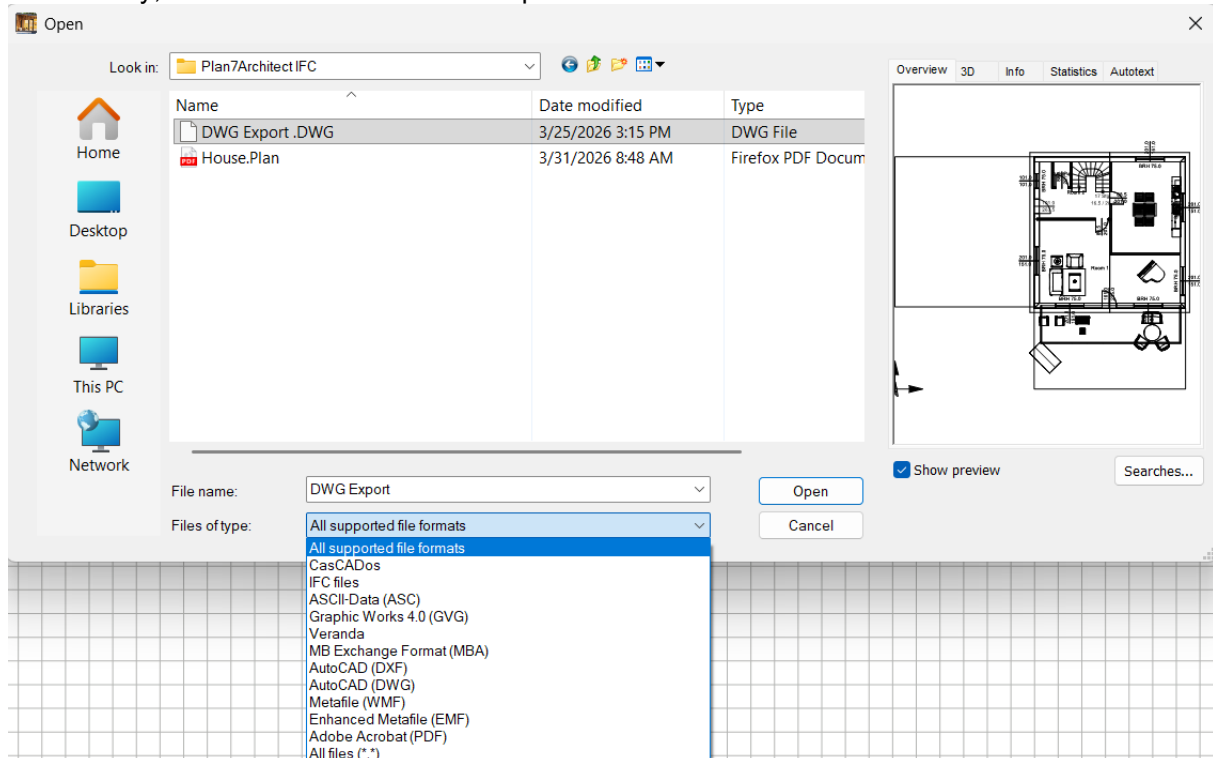

### 3.2.2.4 Exporting DWG/DXF

Various options can be set beforehand when exporting:

You will find the command in the pull-down menu under **Options|Export (DWG/DXF)...**:

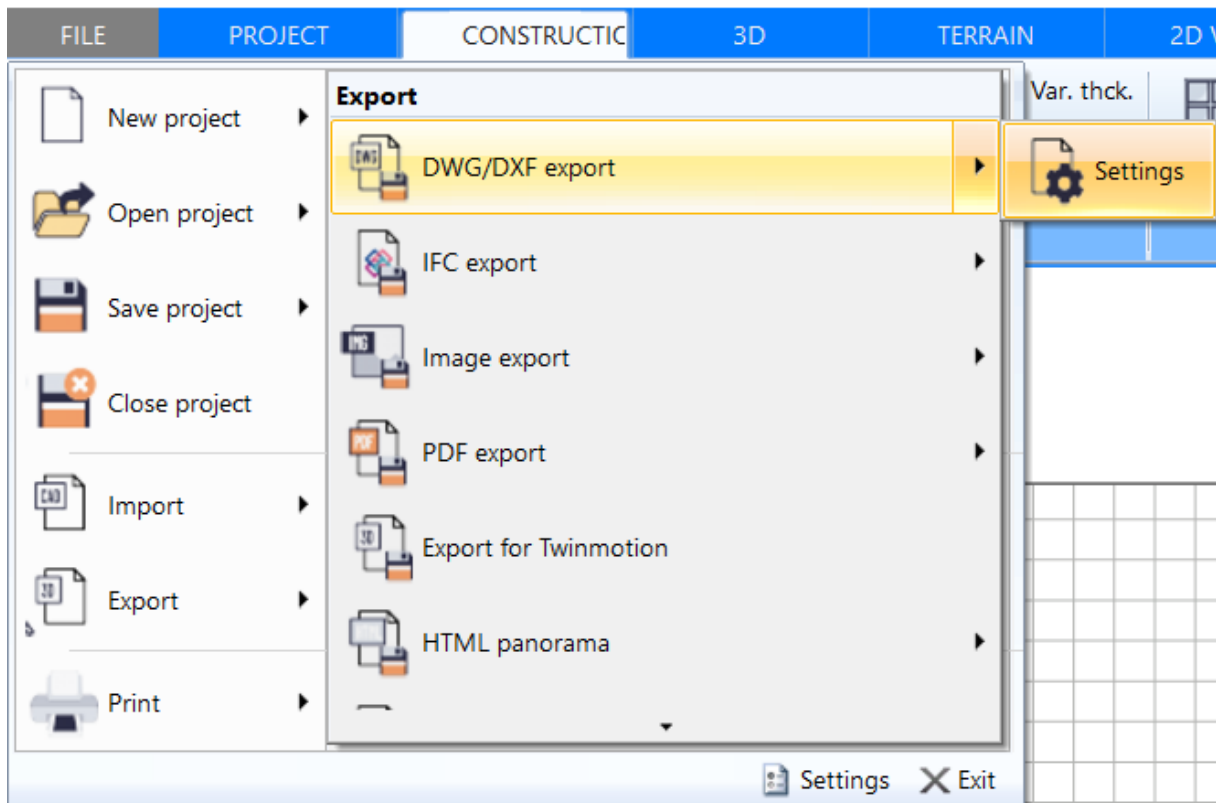

The following input window now appears (*Export AutoCAD DWG/DXF*):

Export AutoCAD DWG/DXF ? X

**AutoCAD colours**      **AutoCAD Layer**

**Export AutoCAD DWG/DXF**

Unit of measurement for DWG/DXF Files:

Export DXF file in binary format

Decimal delimited in DXF file:

Also export hatching  
Remember that the export depends on the type and number of hatching patterns used, and can cause significantly long (time) exports!

Export also fills  
Please note that only their contours are exported in the fill colour!

Ignore fonts types and use the following one:

Font name:

File name:

Determine AutoCAD codepage automatically  
 [1252 (ANSI - Latin I)]

Export as a block :  Any components  
 Walls  
 Beams

Add a floor number to the block name

Ignore double lines

Accuracy:  mm

Export AutoCAD colours

Export AutoCAD lines style

AutoCAD Version:

OK      Cancel      Help

After setting the appropriate options:

Unit of the DWG/DXF files:

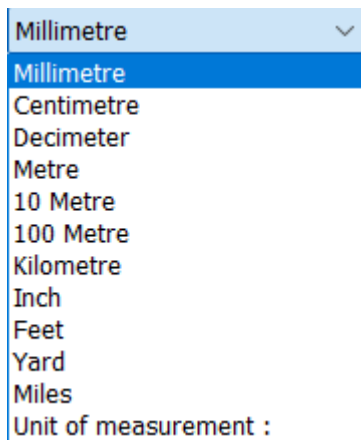

Export DXF files in binary format  
 Decimal separators in DXF files:

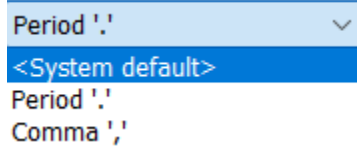

Also export hatchings  
 Also export fills  
 Ignore fonts and use the following font:

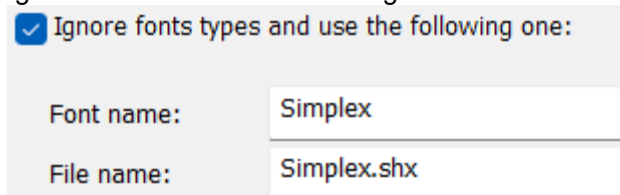

Automatically determine AutoCAD code page

Export as block  
 Walls  
 Beams  
 Other components

Add storey number to block name  
 Ignore duplicate lines  
 Export AutoCAD colors/line styles

the file can be saved under the menu item **File|Export| DXF/DWG Export**

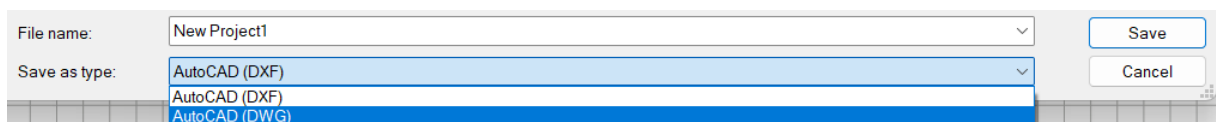

in a folder in the Explorer.

### 3.2.2.5 DXF and DWG file format

#### DWG file format

File format for Autocad from Autodesk. The DWG file format has been continuously adapted and expanded to meet the requirements of the respective AutoCAD versions. For example, the format was changed with the introduction of the AutoCAD 2000, AutoCAD 2004, AutoCAD 2007 and AutoCAD 2010 versions.

#### DXF file format

The Drawing Interchange File Format (DXF) is a file format specified by Autodesk for exchanging CAD data between different CAD programs.

DXF files have a version number, Plan7Architect can read all listed DXF file versions.

Release 10	AC1006
Release 11/12	AC1009
Release 13	AC1012
Release 14	AC1014
Release 2000/0i/2	AC1015
Release 2004/5/6	AC1018
Release 2007/8/9	AC1021
Release 2010/11/12	AC1024
Release 2013/14	AC1027

**Supported geometry elements:** line, arc, circle, spline, text, external symbols and fonts, blocks, dimensions.

3D elements are currently not imported or exported.

**Fonts** are only supported to a limited extent; when exporting, it is usually not known which fonts are on the target system. TTF and similar fonts can be integrated, but only work satisfactorily if they are also present in the target system.

**Hatching** causes similar problems to fonts; here too, blasting the elements offers a possible solution, but this makes subsequent changes very difficult.

In principle, **dimensions** can only be transferred unsatisfactorily, as there are too many standards for their formatting. They can also be transferred visually clean by breaking them down into basic elements, but the associativity is lost.

Data exchange between CAD systems is only possible in a few cases without improvements.

For historical reasons, the "line thickness" attribute of an object could not be transferred directly with DXF/DWG. In this case, the "color" information of an object was used as a substitute for assigning a specific line thickness.

## 3.2.3 Image files

### 3.2.3.1 Import image files

This chapter describes how to load pixel files in Plan7Architect. This applies to all 2D modes.

## 3.2.3.1.1 Import image file button

Image files can be inserted in Plan7Architect.



To do this, select the **Import image file** button in the construction bar. Alternatively, you can also use **File|Import|Import image**.

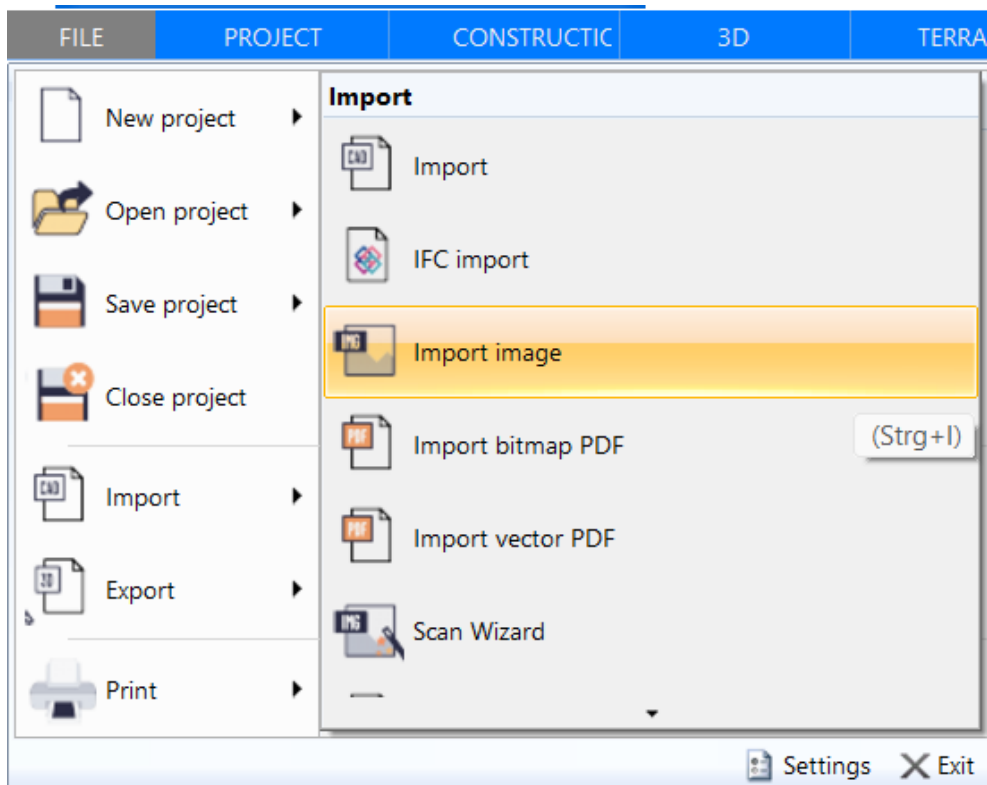

The Windows dialog for opening the desired file opens. The file is placed in the current layer in the middle of the planning. The image is displayed in the calculated size as a rectangle.

Clicking on the imported image opens a bar with the following properties dialogs:

- **Image editing**
- **Image snap points**
- **Layer/Floor**
- **Size/Position**



Image **editing** properties dialog

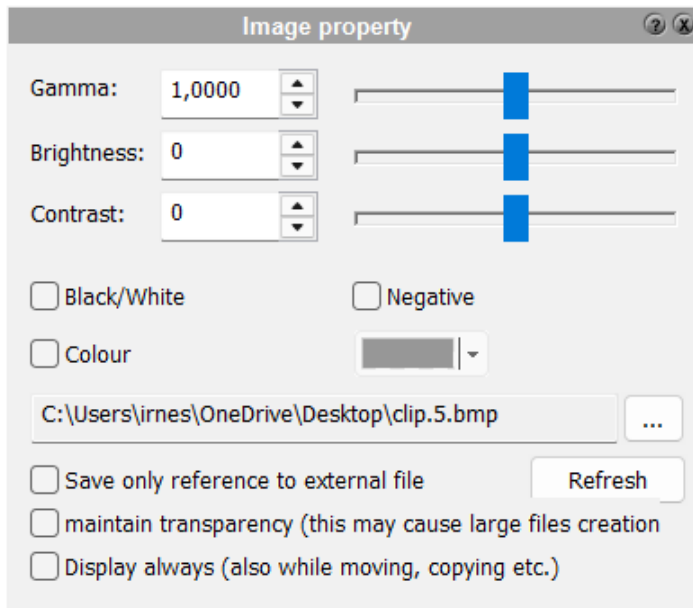

Properties of the image file can be changed here, e.g. brightness, contrast

**Image snap points** properties dialog

If required, snapping to image points can be activated here.

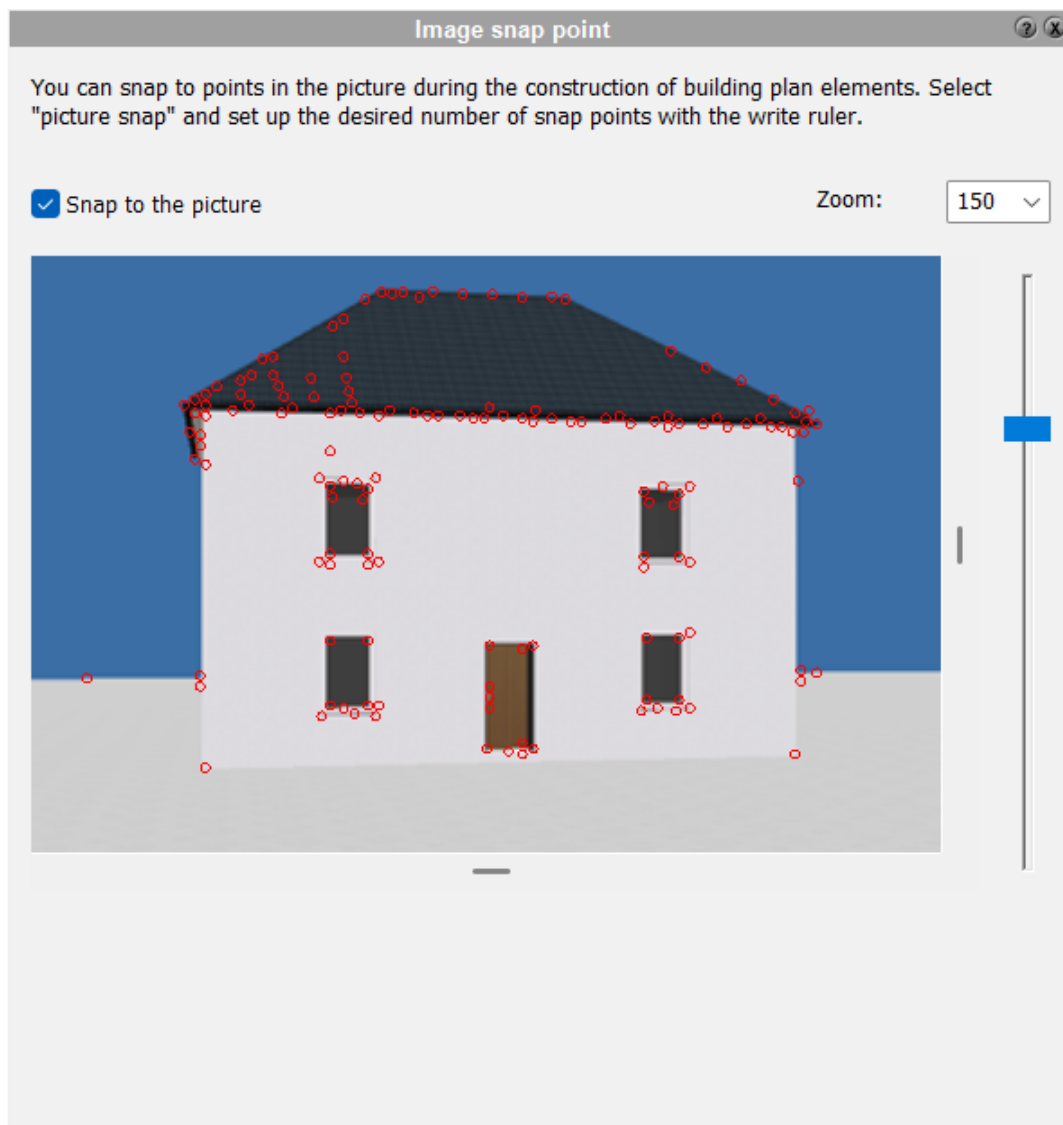

For information on the [Layer/Bullet](#)<sup>[143]</sup> and [Size/Position](#)<sup>[143]</sup> properties dialogs, please refer to the [General properties dialogs](#)<sup>[134]</sup> chapter.

### 3.2.3.2 Export image files

This chapter describes how to save pixel files from Plan7Architect. You can save from the 2D modes as well as from the 3D mode.

Start the process in the menu bar under **File|Export|Save as image file...**

#### 3.2.3.2.1 From the 2D modes

The **file save dialog** opens. Select the storage directory and enter the file name.  
Select the desired options:

Select the desired file format and save the file.

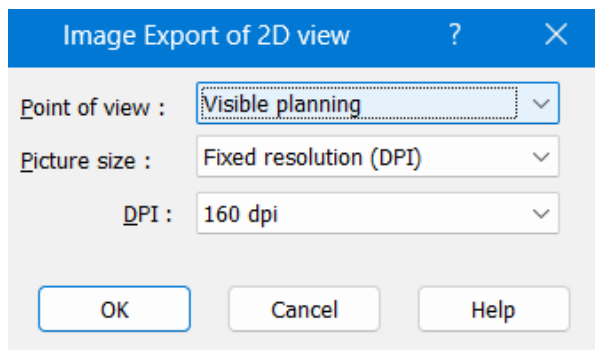
**Image size:**

**Fixed resolution (DPI):** Under DPI, set the dots per inch for the image size.

**Fixed size:** Define a fixed image size in pixels (px).

**Section:**

**Visible planning:** The section is automatically adjusted to the size of all visible (observe layer visibility) elements.

**Entire sheet:** The entire sheet is exported.

**Current section:** Only the section of the planning currently visible on the screen is exported.

## 3.2.3.2.2 From 3D mode

In 3D mode, a dialog appears to set the picture quality and resolution:

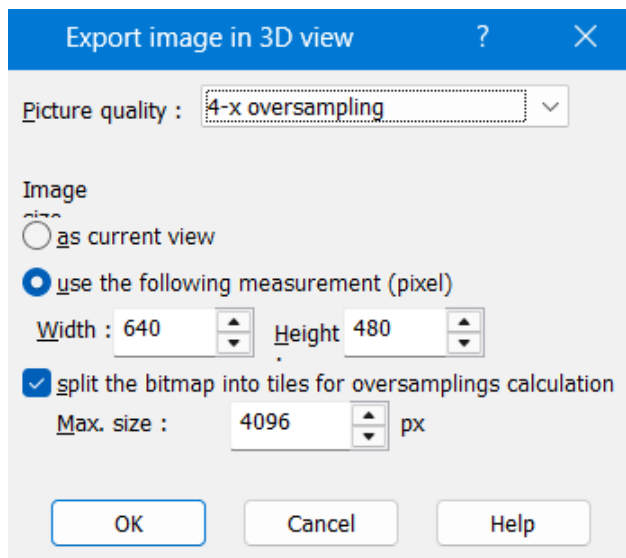

The image quality (oversampling or anti-aliasing):

The individual pixels result in a so-called staircase effect (aliasing) at the edges of the graphic, which can be optically compensated for by anti-aliasing (edge smoothing). This involves adding intermediate tones to the edges, which improves the visual representation.

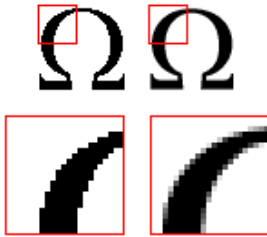

In the example shown above, gray tones have been added to the exact black and white edge, making the edge look smoother.

The current image section is saved in the image file.

### 3.2.3.3 Scan-Wizard

The scan assistant supports you in the task of inserting an image file into the planning to scale. Typical applications include importing a site plan or an as-built plan.

You start the wizard via the **File|Scan Wizard** menu.

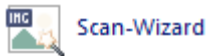

The main difference to the conventional importing of image files with the corresponding 2D tool is the scaling of the image to the current project scale. To do this, the wizard prompts you to select two points in the image and enter the distance between these points. This allows you to determine the actual size of the template.

The imported image is stored on the **Background floor plan** layer. This assignment can be changed at any time. Of course, you can import as many image files as you like into a project using the wizard.

#### 3.2.3.3.1 Reload drawing (image)

##### Step 1 - Load the drawing (image):

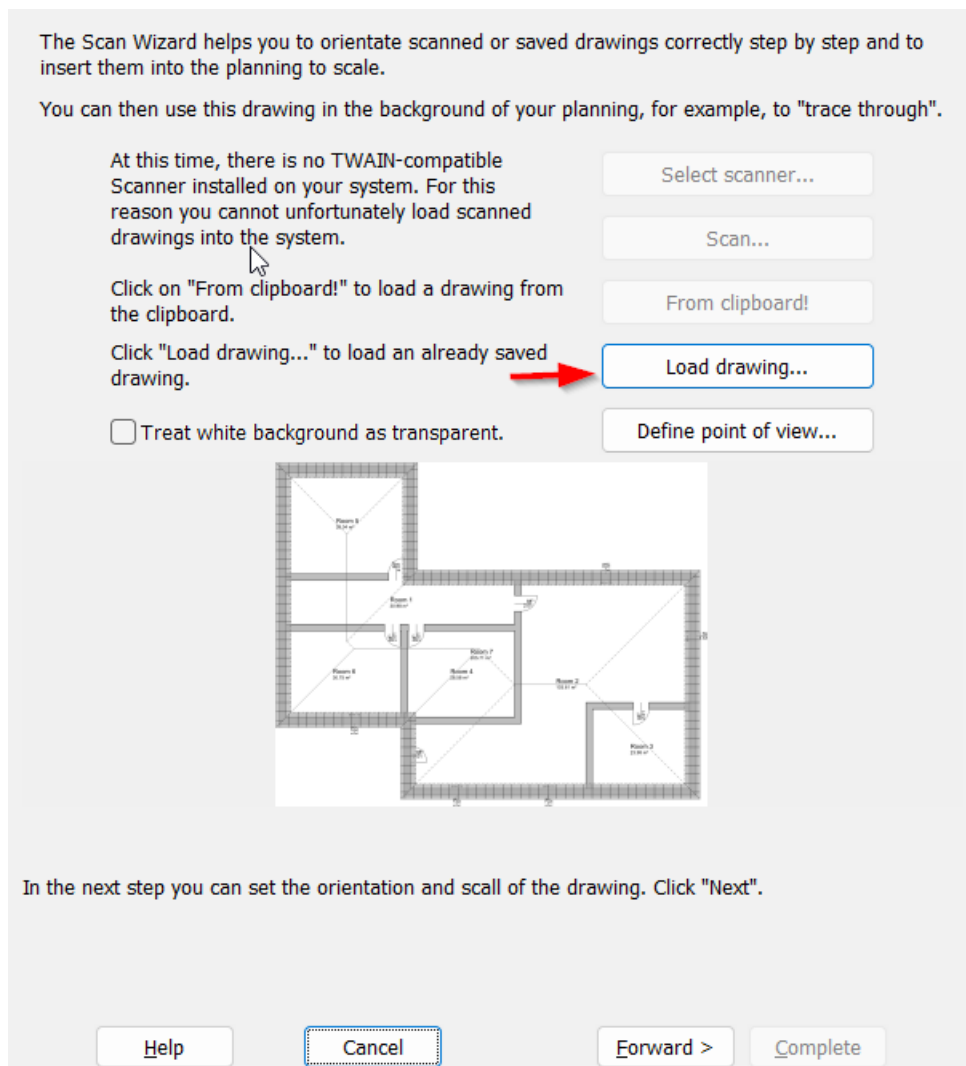

The drawing can be loaded either via a scanner or directly as a file.  
If the entire drawing is not to be imported, a section can be defined using the **Define section** button.  
You can also import a previously copied image file from the **Windows** clipboard.  
The **white background** can also be made transparent.

#### 3.2.3.3.2 Optimize drawing (image)

### Step 2 - Optimize the drawing (image):

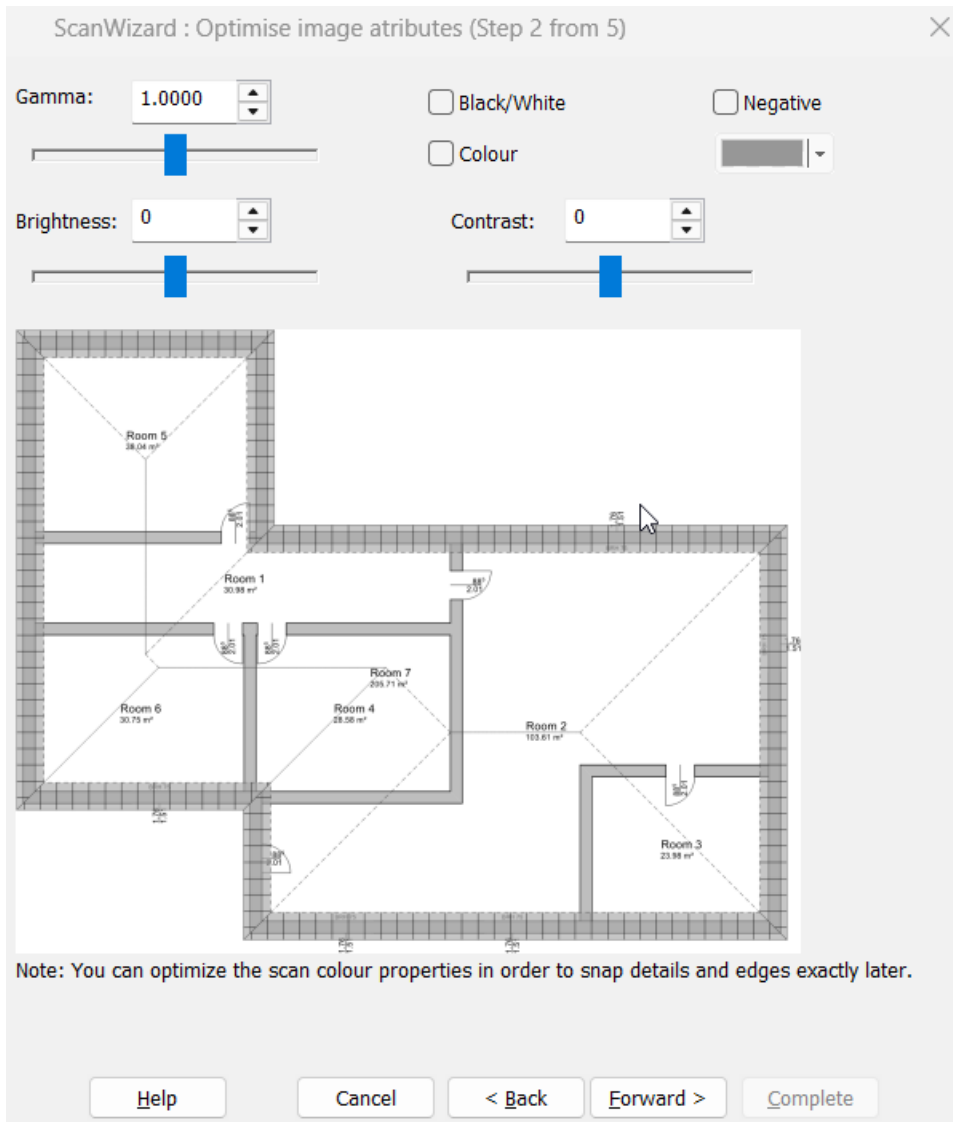

Adjust the contrast and brightness to the template. The preview always shows the current settings.

### 3.2.3.3.3 Alignment

#### Step 3 - Alignment:

On this page of the Scan Wizard you can rotate and mirror the drawing if it does not correspond to the desired orientation. Use the toolbar on the right to do this.

You can click twice inside of a picture to create a line that will serve at the Scan-Wizard for the next step: horizontal or vertical respectively.

Zoom: 28

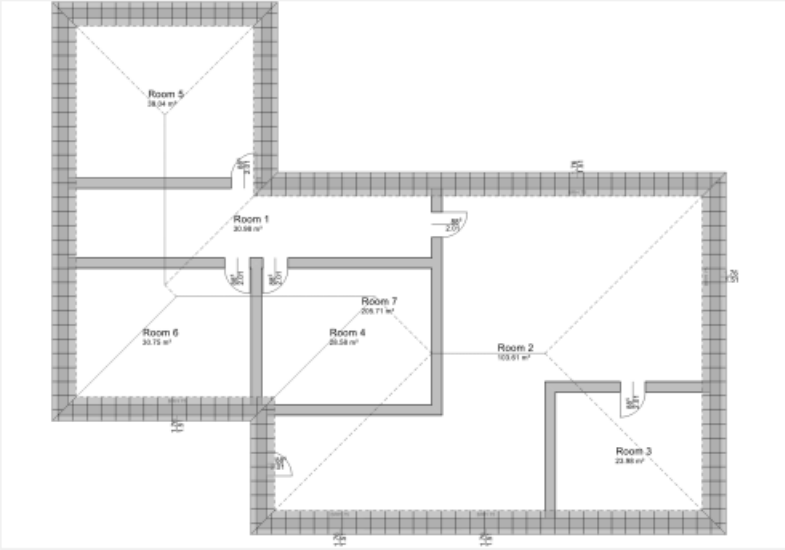

Note: You can move by clicking in the drawing and then drag with mouse while holding a down a mouse button.

When you are satisfied with this setup, click "Next>" to continue settings definition.

Help Cancel < Back Forward > Complete

Scanned templates are often not precisely oriented. In this dialog, a line can be drawn (by clicking twice in the drawing), which is assumed to be horizontal (or vertical) during import (appears as a red line). Rotating by 90° or mirroring is easy with the buttons on the right.

#### 3.2.3.3.4 Determine scale

### Step 4 - Determine the scale:

The drawing ruler is set up with the Scan-Wizard. Click twice to define a displacement.

Drag to the to the input field

Zoom: 28

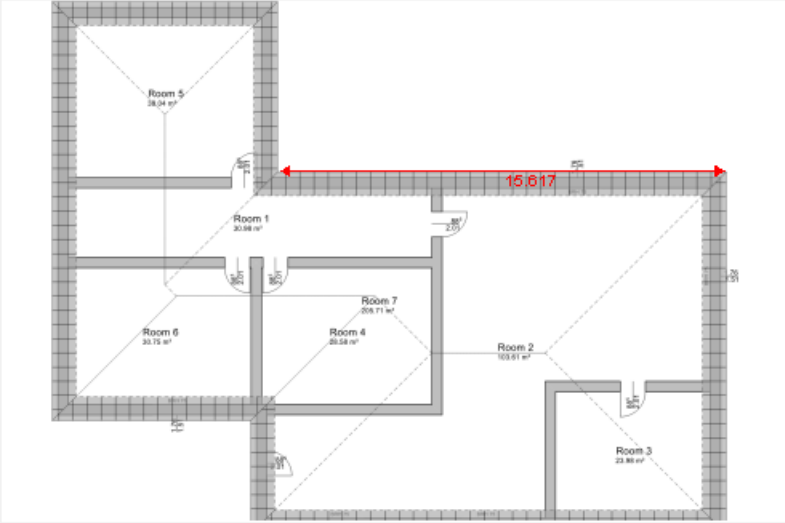

Note: You can move by clicking in the drawing and then drag with mouse while holding a down a mouse button.

Your setup is complete. Click "Apply" to accept. If you would like to recall an input, you can click "Go Back (or undo)" also the previously entered Scan-Wizards will be retrieved.

Help Cancel < Back Forward > Complete

Click on two points in the graphic whose distance is known. You will then be asked for the distance. It is advisable to use two points as far apart as possible, as this increases the accuracy.

Please provide the length of the selected cross section.  
From here on, the scan scale will be calculated accordingly.

Length:  cm

OK Cancel

### 3.2.3.3.5 Catch points

#### Step 5 - Snap points:

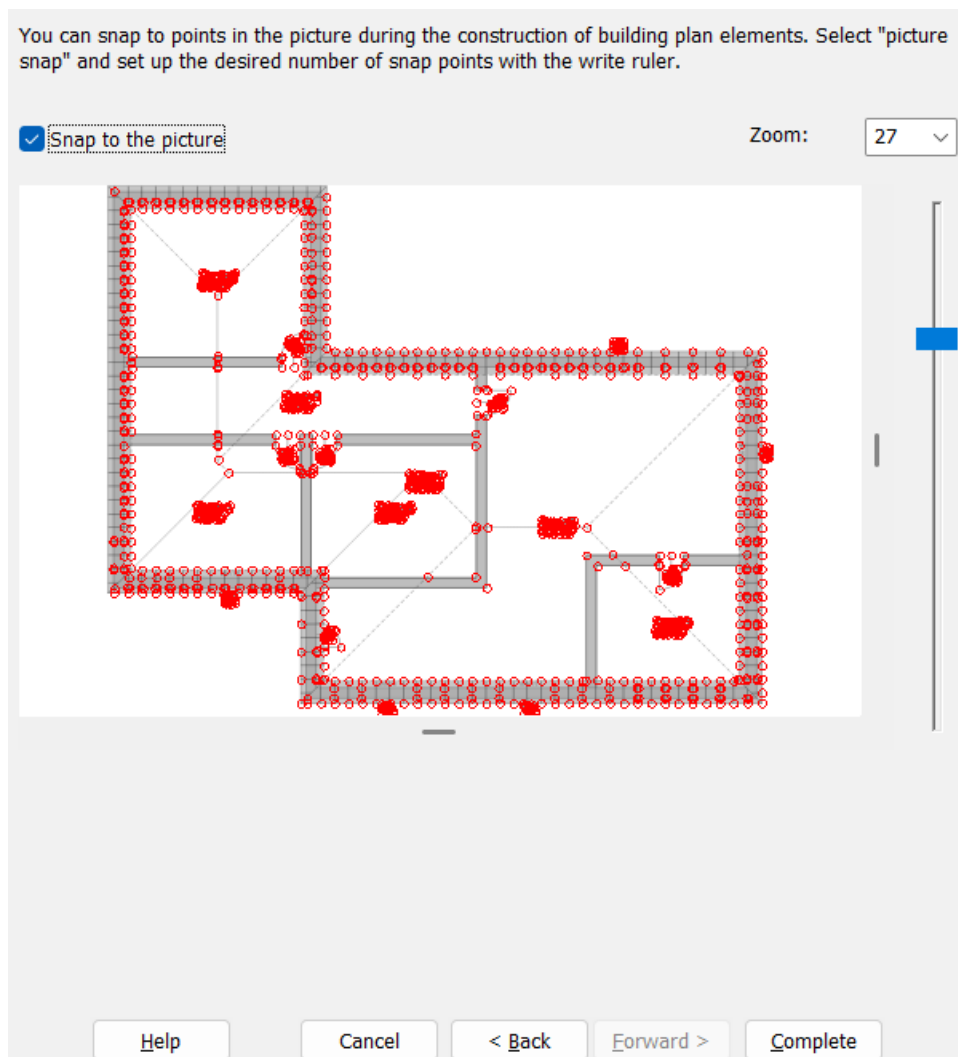

Finally, you can specify whether the imported image should be snapped to. The program attempts to determine all characteristic corner points. The fineness of this sampling (= number of snap points) is defined in the slider on the right.

Now click on **Finish**. The image file is saved in the correct size and orientation on the **Stored floor plan** layer.

### 3.2.4 PDF

#### 3.2.4.1 Read PDF as bitmap

PDF files can be imported to scale.

The PDF file is called up via the menu item **File|Import|PDF Import Bitmap...** menu item:

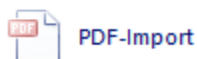

If the entry **PDF ...** entry is selected, a preview appears:

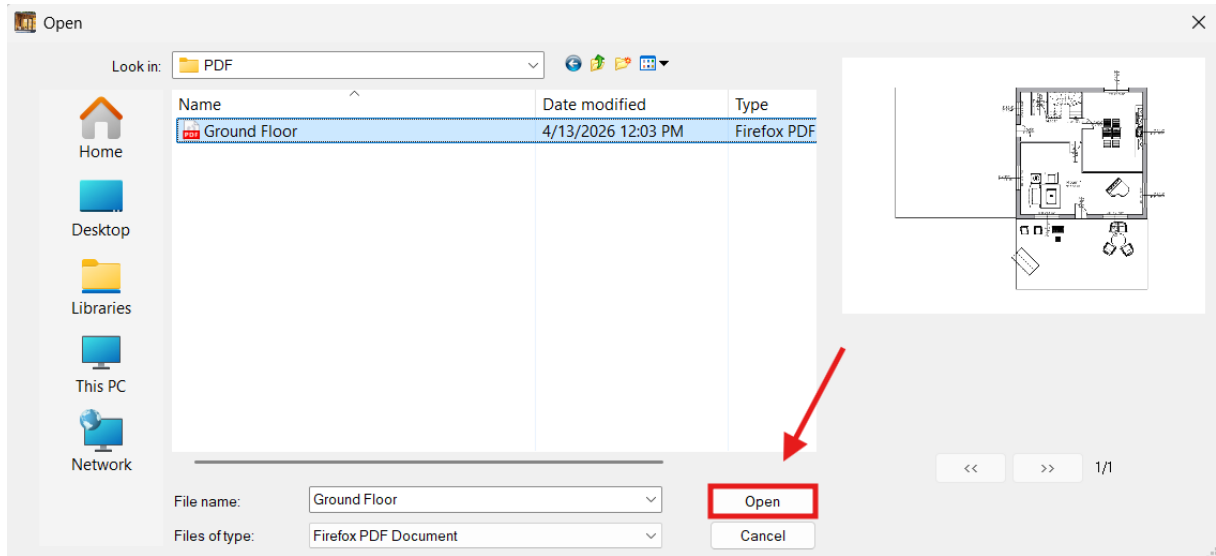

Select the desired file and click on the **Open** button

The scale can now be set:

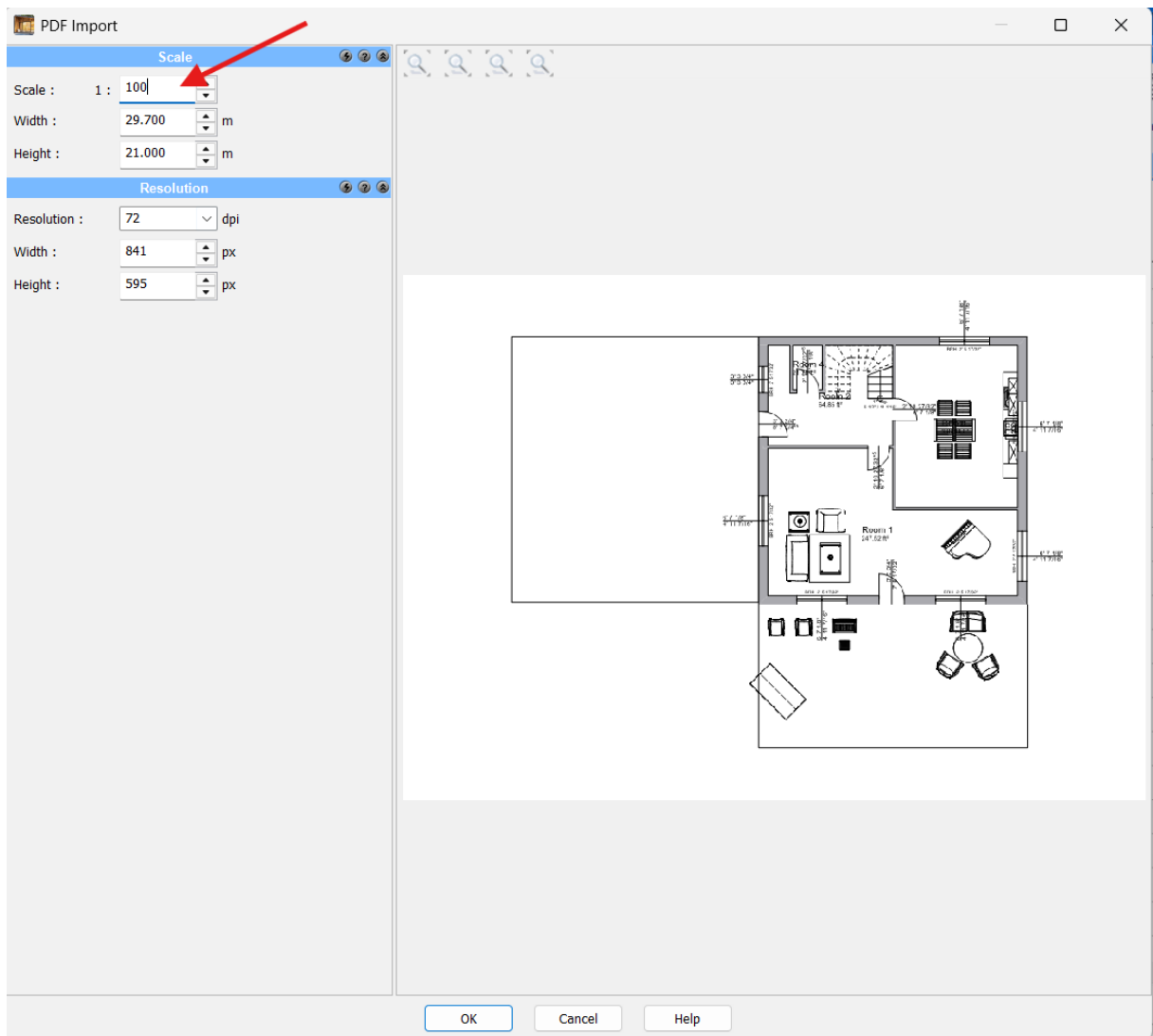

and the contents of the PDF file are placed on the current layer:

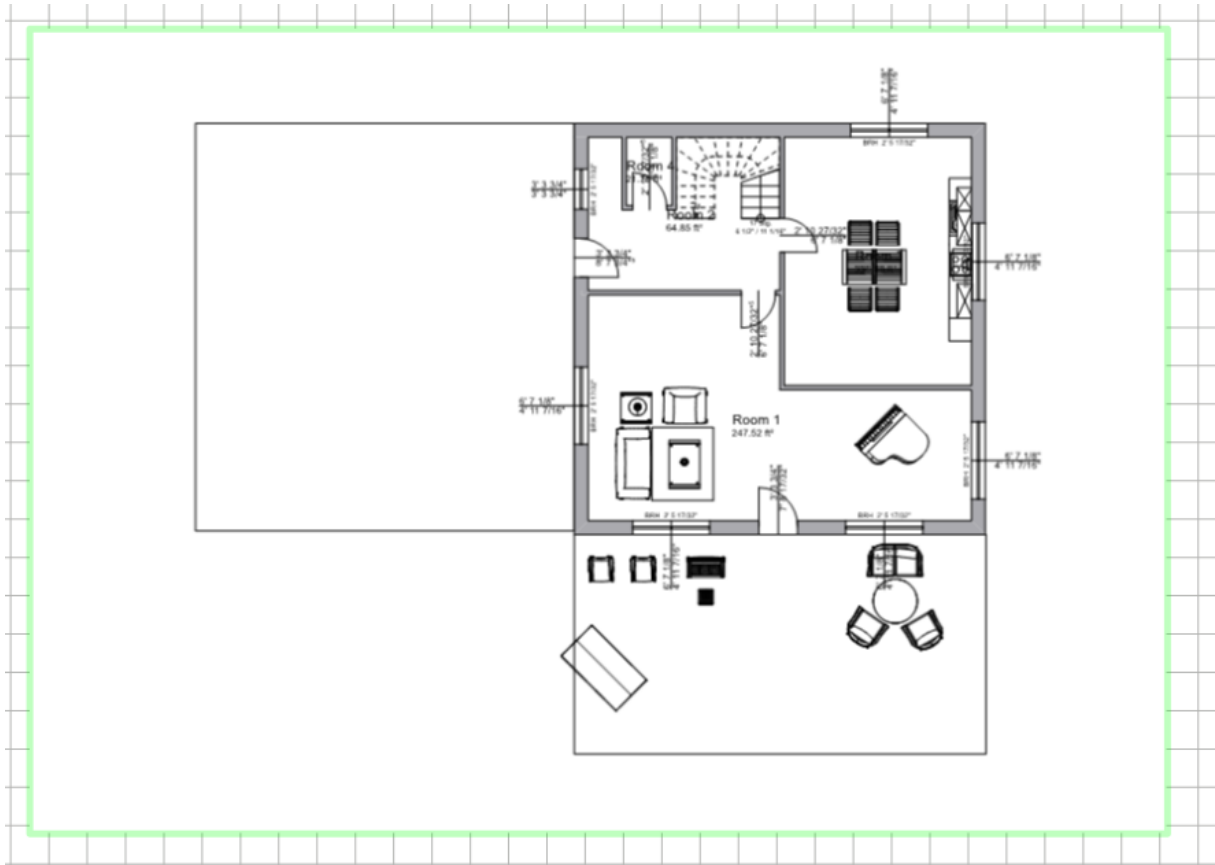

### 3.2.4.2 Read PDF with vectors

The PDF file is opened via the menu item **File|Import|PDF Import Vector...** menu item. For a vector import, the PDF file must of course also contain vectors.

**The import dialog:**

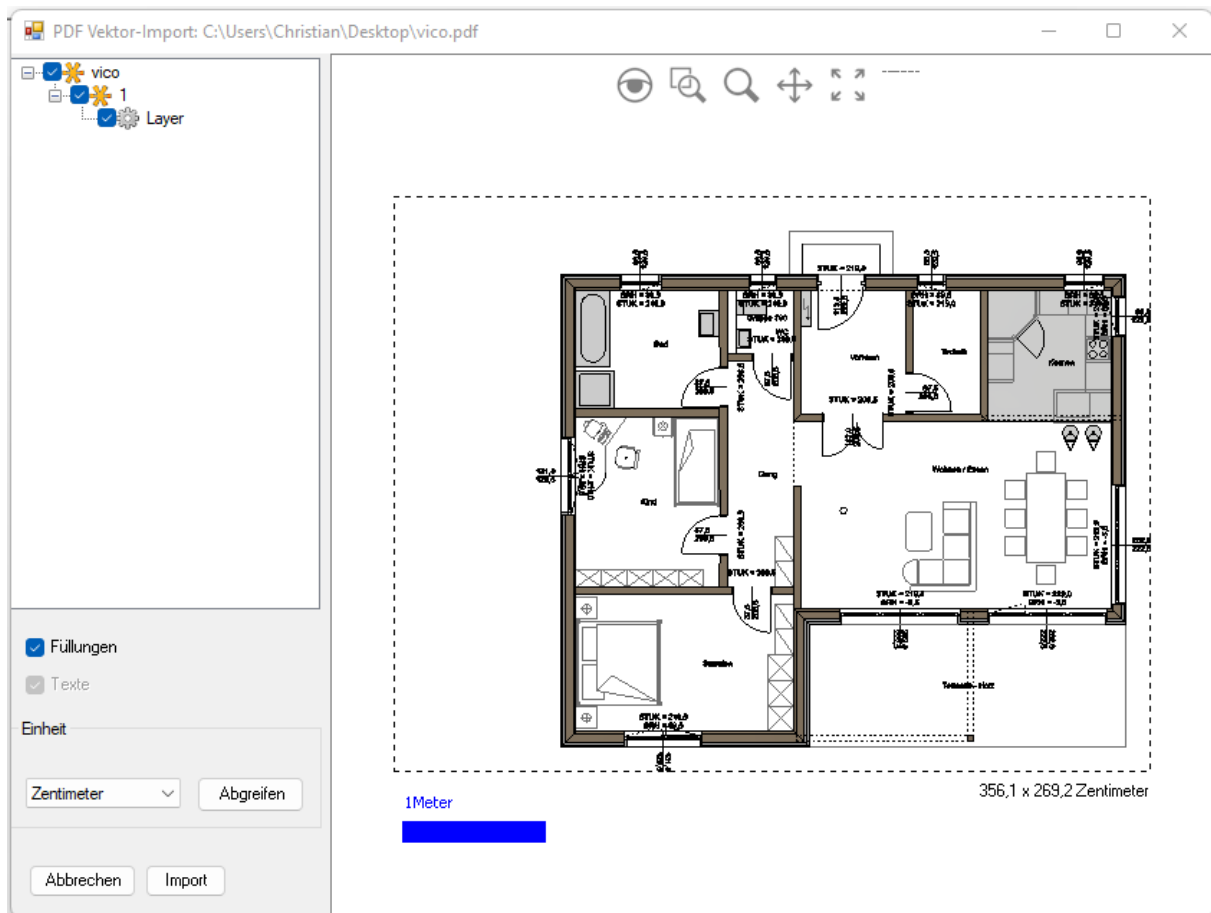

The page and the layers that are to be imported can be selected in the selection at the top left. If the PDF file contains fills and texts, the import can be defined with the respective option.

The import scale can be determined with the unit. The blue size scale at the bottom of the display shows the current import scale in relation to the PDF content.

### 3.2.4.3 Output PDF

The visible data can be output directly as a PDF from any mode. This is accessed via the menu bar under **File|Print as PDF...**



The export options now appear. Set the **desired resolution** in dpi (dots per inch) and/or the *maximum* size in px (pixels) and/or define a **DIN export format**:

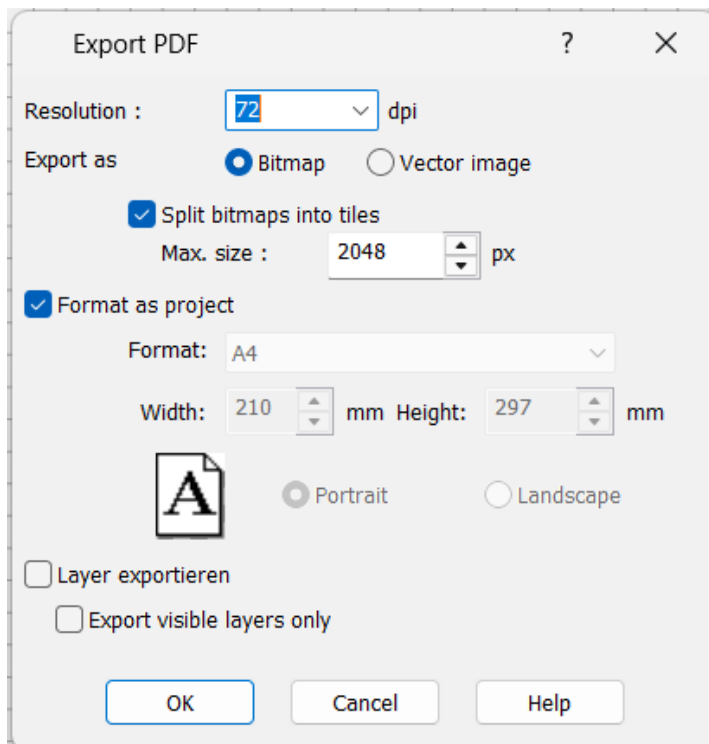

Click **OK** to save the PDF file:

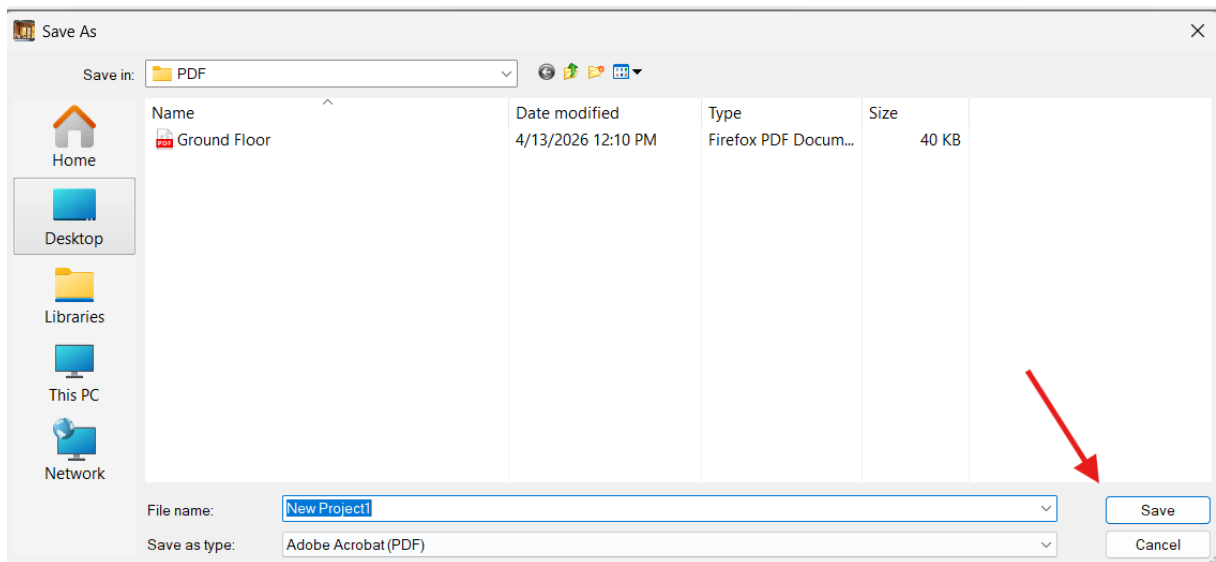

The PDF file is then saved directly to the selected folder.

#### 3.2.4.4 Export PDF with vectors

The PDF export function is accessed in the menu bar under **File|Export|PDF export...** :

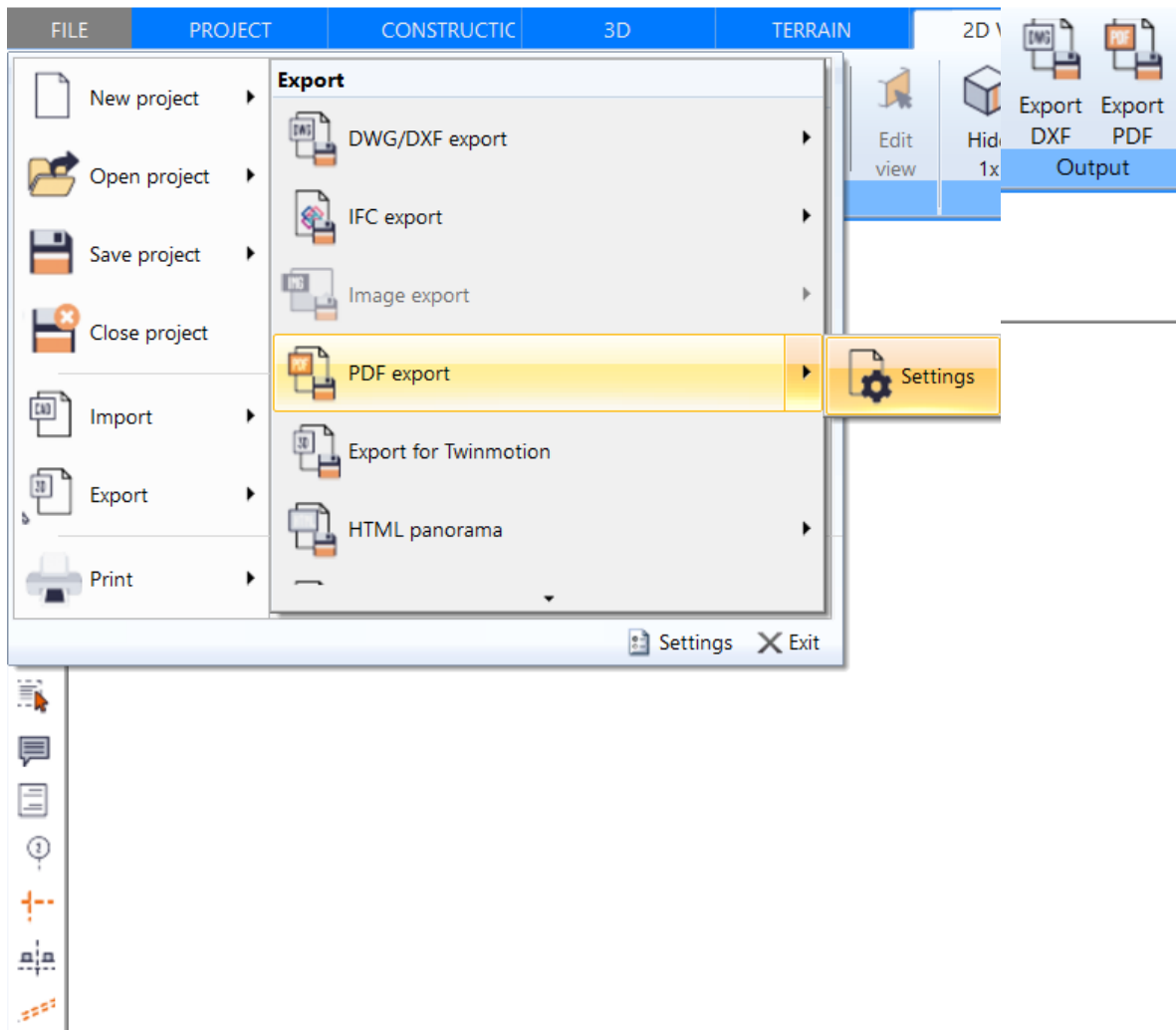

PDF files can contain **bitmaps** and **vectors**.

If you import a PDF file, you can select whether the file is imported as a bitmap (with the selected resolution) or as a vector graphic.

The prerequisite for a vector import is, of course, that the PDF file already contains vectors.

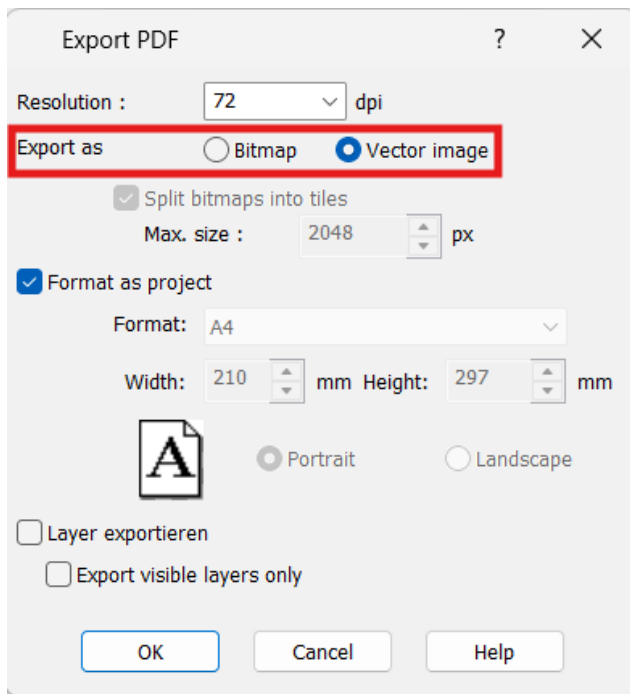

Set the desired resolution in the drop-down field and select an export format if required:

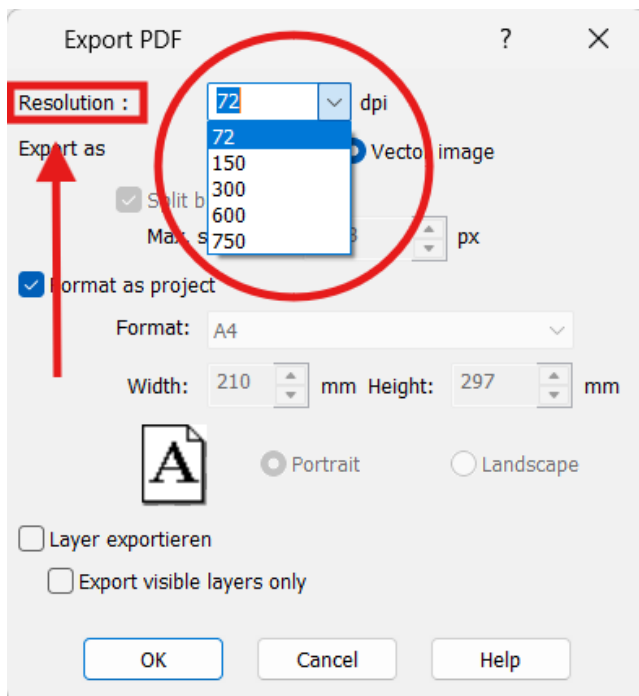

## 3.2.5 3D Models

### 3.2.5.1 Export 3D-VRML

The export of the 3D model into a VRML scene is carried out in the pull-down menu under **File|Export|As VRML...** When exporting VRML, various settings can be set in the **Options** menu beforehand :

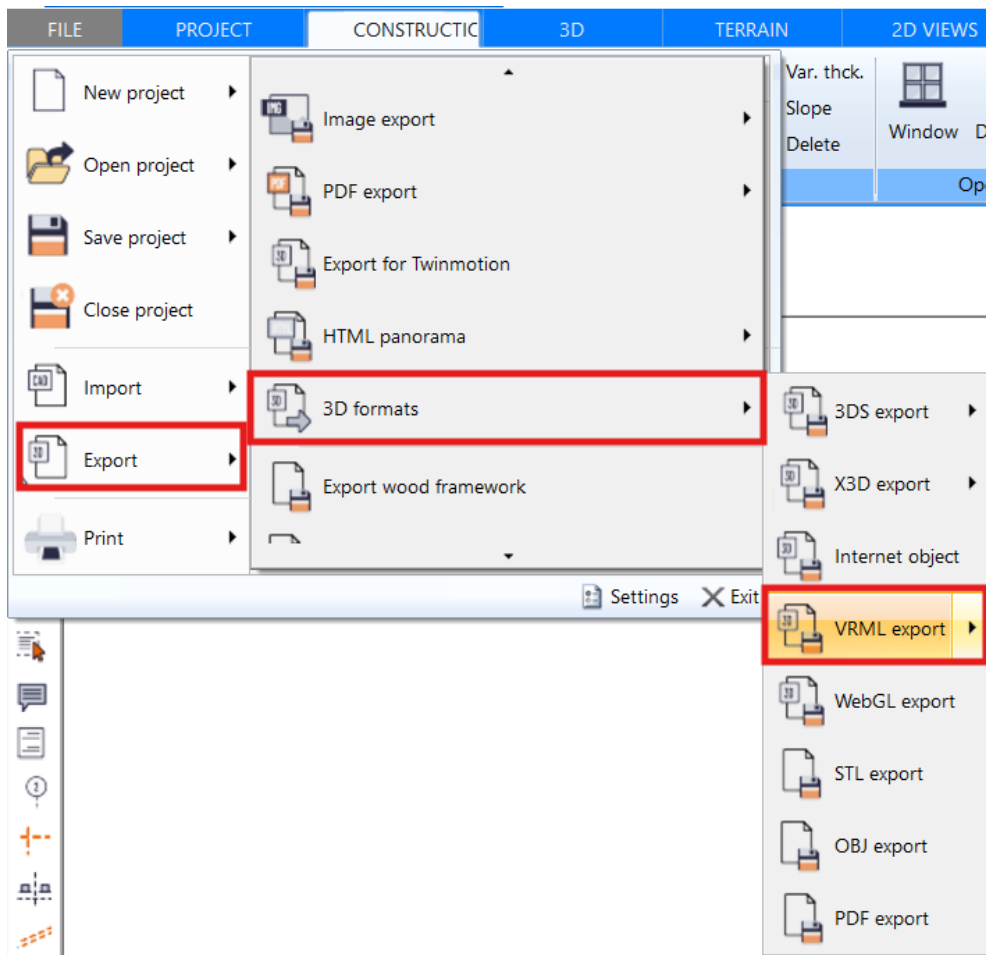

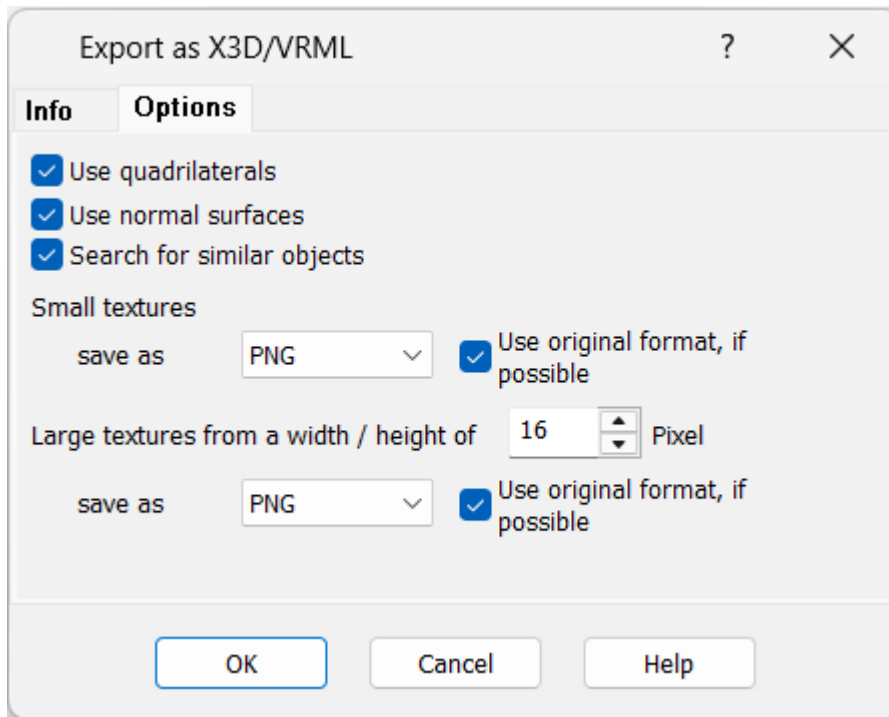
**Options:**

Use rectangles  
Use surface normals  
Search for similar objects

**Small textures**

Save as (select file format) / use original format if possible

Large textures from a height / width of pixels

Save as (select file format) / use original format if possible

**3.2.5.2 Export 3DS**

The export of the 3D model to a 3DS scene is carried out in the pull-down menu under **File|Export|As 3DS**.

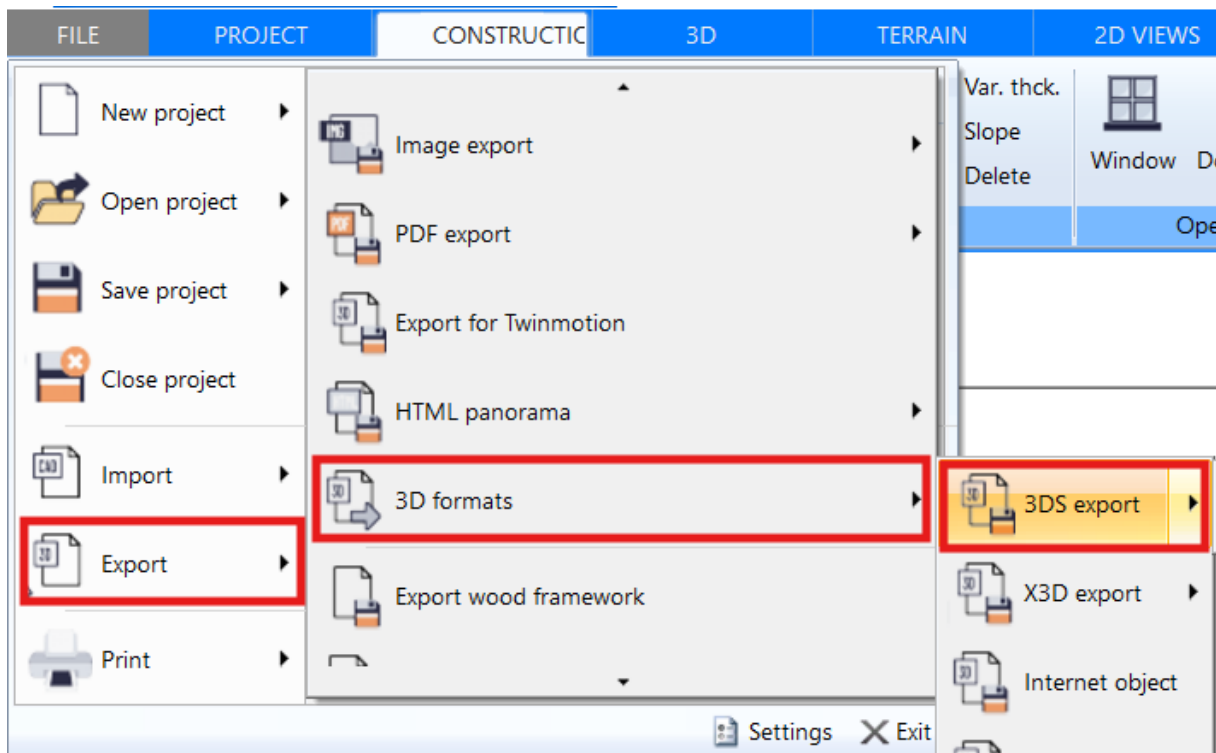

Beforehand, you can specify the export options under **Options|Export (3DS) ...**:

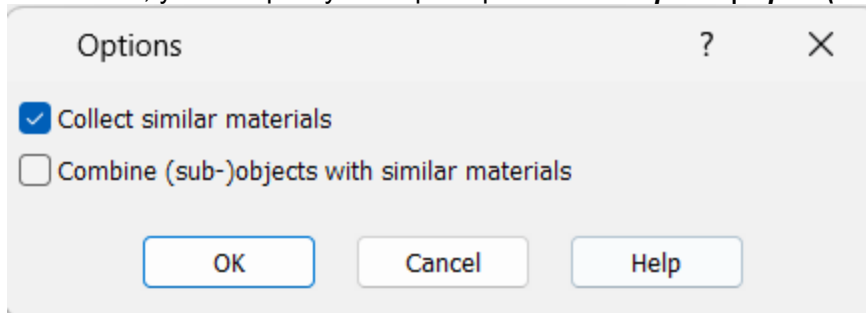

### 3.2.5.3 Export X3D

The export of the 3D model to an X3D scene is carried out in the pull-down menu under **File|Export|As X3D...**

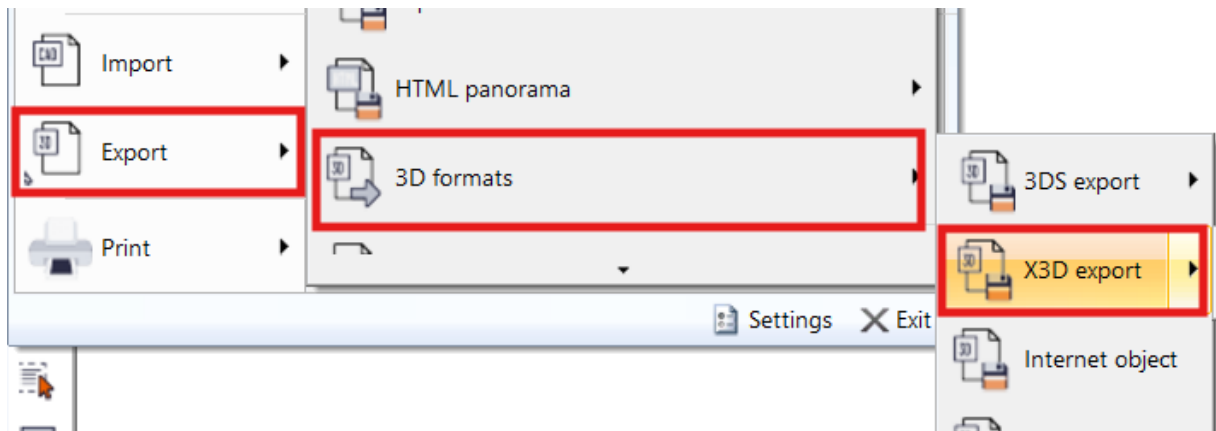

### 3.2.5.4 Export as panorama

The export of the 3D model as a panorama is carried out in the pull-down menu under **File|Export|Html-Panorama....**

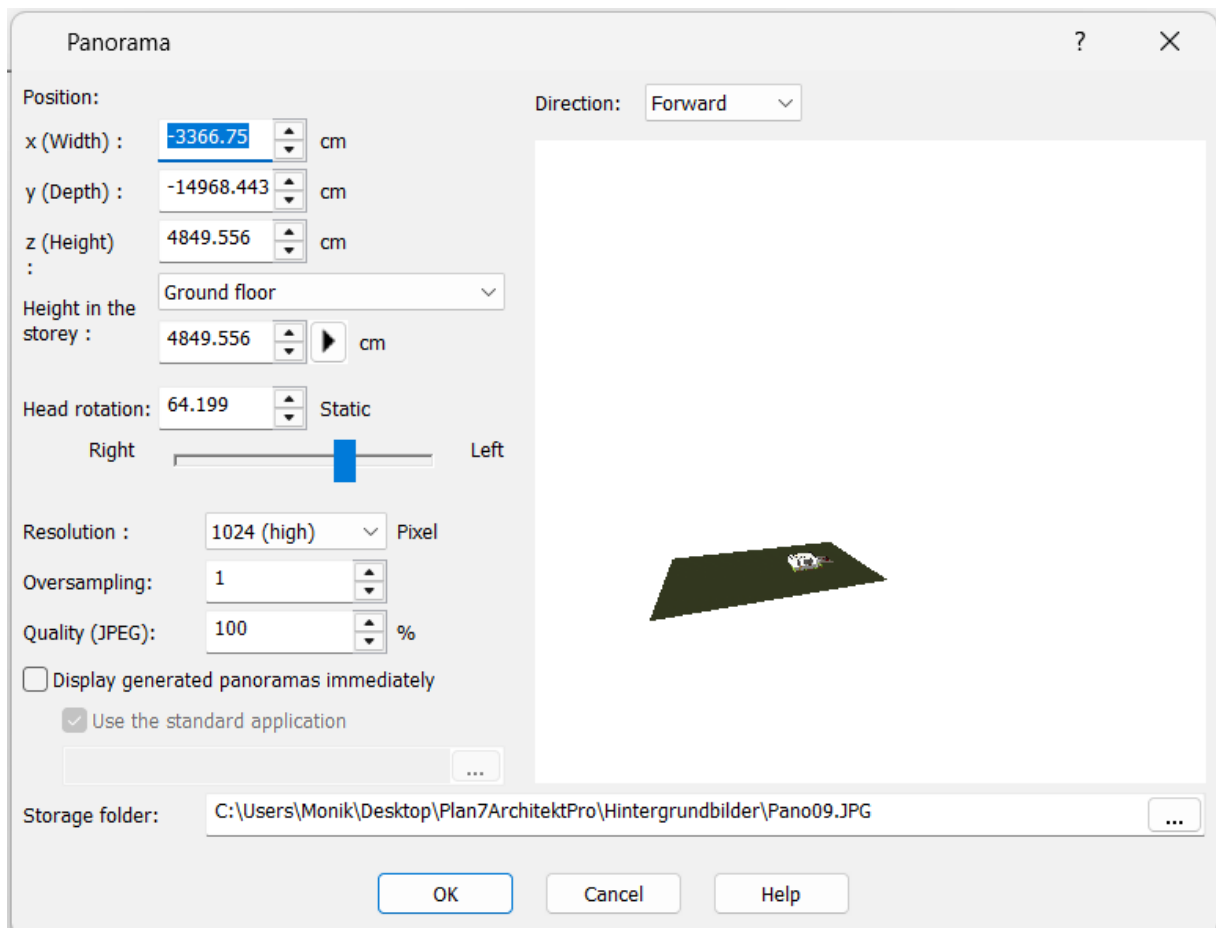

Position (width/depth/height): Align the view to be exported here

Direction (front/back/right/left/top/bottom: Specify the direction

Height in storey: Select a storey and specify the view height

Head rotation: Rotate the perspective

Resolution/Oversampling/Quality (JPEG): Make the quality settings here (the higher these are selected, the larger the export file will be)

Show created panoramas immediately: Opens the panorama with any image program (selectable below)  
Use default application: Opens the file with your default image program

Save folder: Select here where the panorama should be saved

Alternatively, you can access the export settings for resolution/oversampling/quality via the drop-down menu under **Options|Export panorama...**

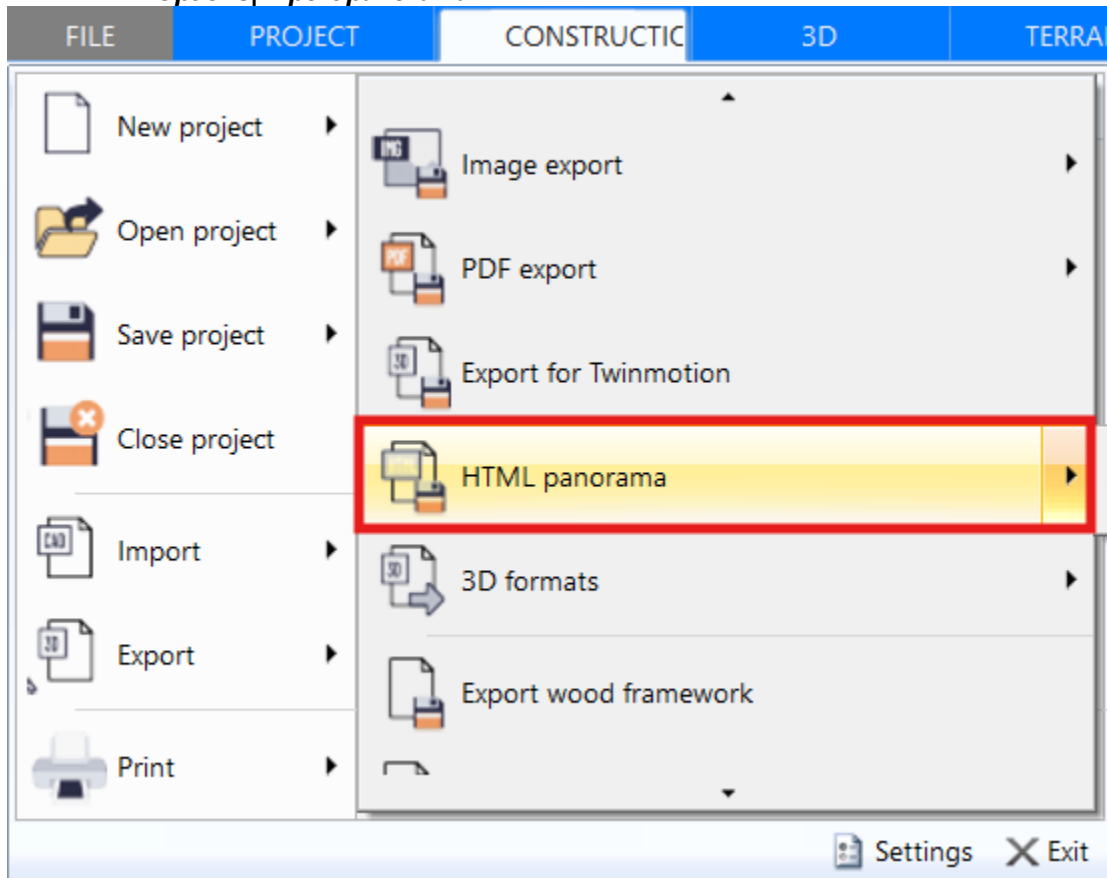

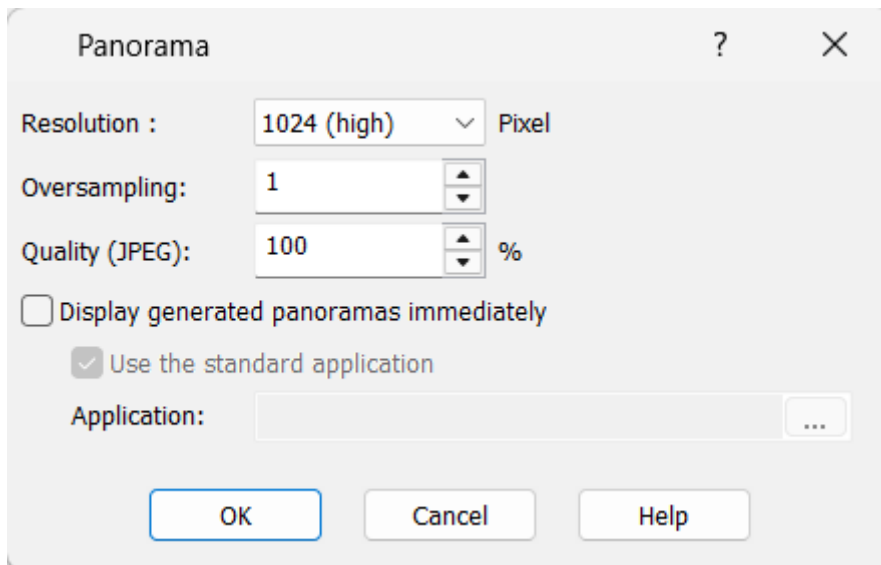

### 3.2.5.5 Import Sketchup SKP

With the Load object function in 3D mode



function can also be used to load Sketchup SKP files.  
Please note

- the size of the files. Large 3D objects can impair the performance of the software.
- the scaling. Imported SKP objects may still need to be scaled correctly.
- Deleting parts of an SKP object is not yet supported.

### 3.2.6 Other providers

You have the option of exporting projects created with Plan7Architect to KeyMark®, WETO and ARCHIKART; the commands for this can be found in the drop-down menu under **File|Export**.

## 3.3 Program

### 3.3.1 Save

You will find the save settings under **Settings**

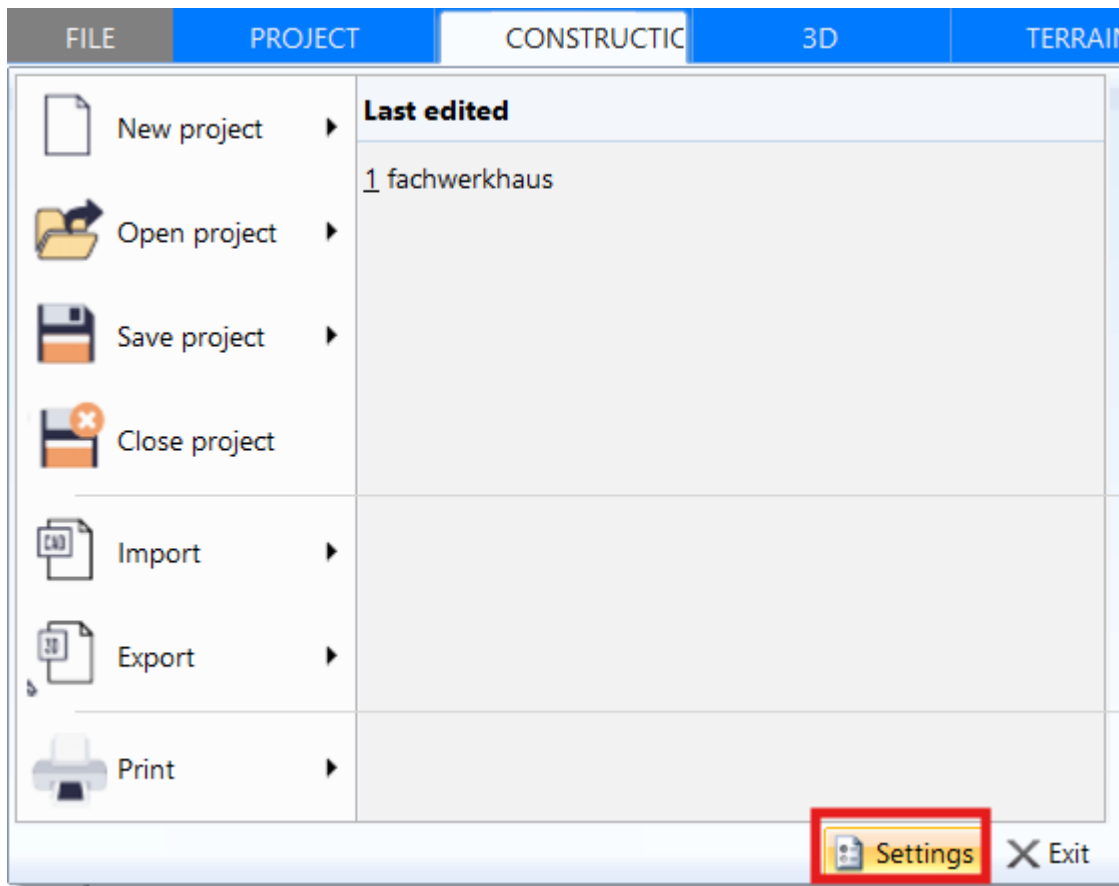

The following dialog box now appears with the save options:

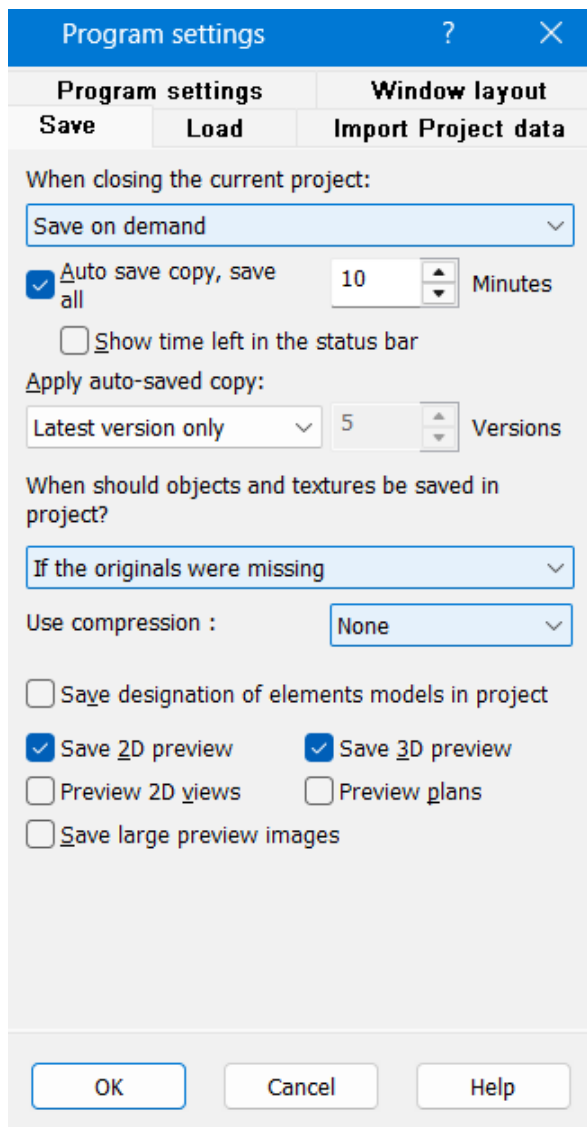

In the upper area of the **Save** tab, you can set how Plan7Architect behaves when a project is closed. The setting **Save on demand** is recommended.

#### **Automatic backup copy**

The lower area concerns the automatic backup of the project during editing. In this case, a backup file is created **every ten minutes**.

The backup file has the same name as the project file, but with the extension **.autobackup** and is located in the project file directory. If you reopen the project after uncontrolled termination, the following message appears:

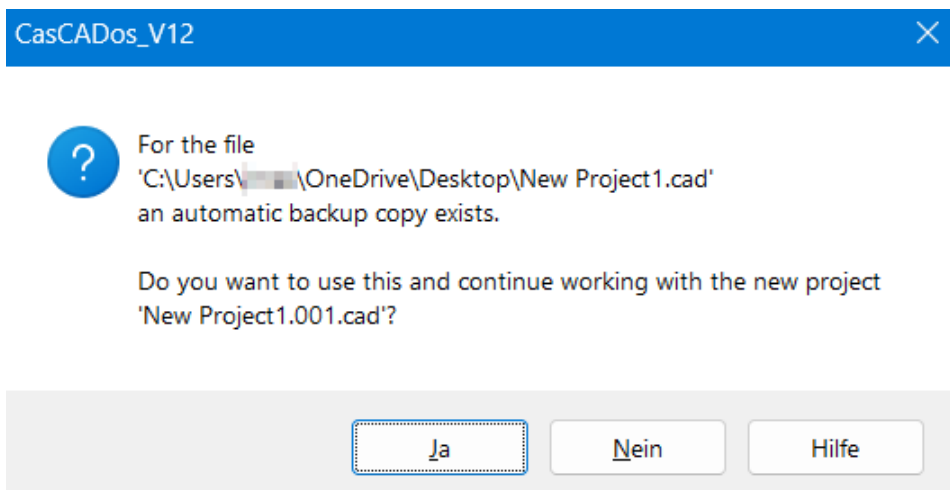

Select **Yes** to continue editing with the automatic backup. **ATTENTION!!! No** deletes the backup file. If you use the automatic backup, the project file is renamed to **Project.001.cad** and opened immediately. The automatic numbering is carried out consecutively, all old project statuses are therefore retained, the current project file is the one with the highest number. The file *Projectname.cad.autobackup* is a conventional project file except for the file extension. By changing the file extension from *.autobackup* to *.cad*, the file can also be opened directly with Plan7Architect.

### Backup copy

The **Create backup copy** parameter does not affect the automatic backup at the specified time interval; the backup copy is created during conventional saving (with the **Save** command or by exiting the program with **Save**). The backup copy has the same name as the project file itself, but also has the file extension *.bak*. A backup copy can be opened again directly with Plan7Architect by renaming it to a **.cad file**.

The content of the backup copy is the same as the content of the project file before saving. Optionally, several versions of these bak backups can be created.

## 3.3.2 Saving objects and textures in the project

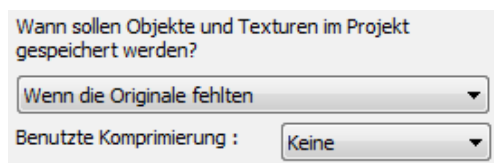

These settings only affect 3D objects and materials, all other information is always saved in full in the project file.

3D objects and materials are stored in a database in Plan7Architect. In a project, only the reference to the element is stored in the database. This has the advantage that the file size of projects is very small.

When a project is loaded, the required references of objects and materials are automatically searched for and used in the database.

However, if you want to pass on the project, you must ensure that all elements are saved in the file. This is achieved with the **Share** command in the **File** menu. If you open such a "passed on" file yourself, it is necessary to specify what should happen to any elements that are not present when such a file is saved.

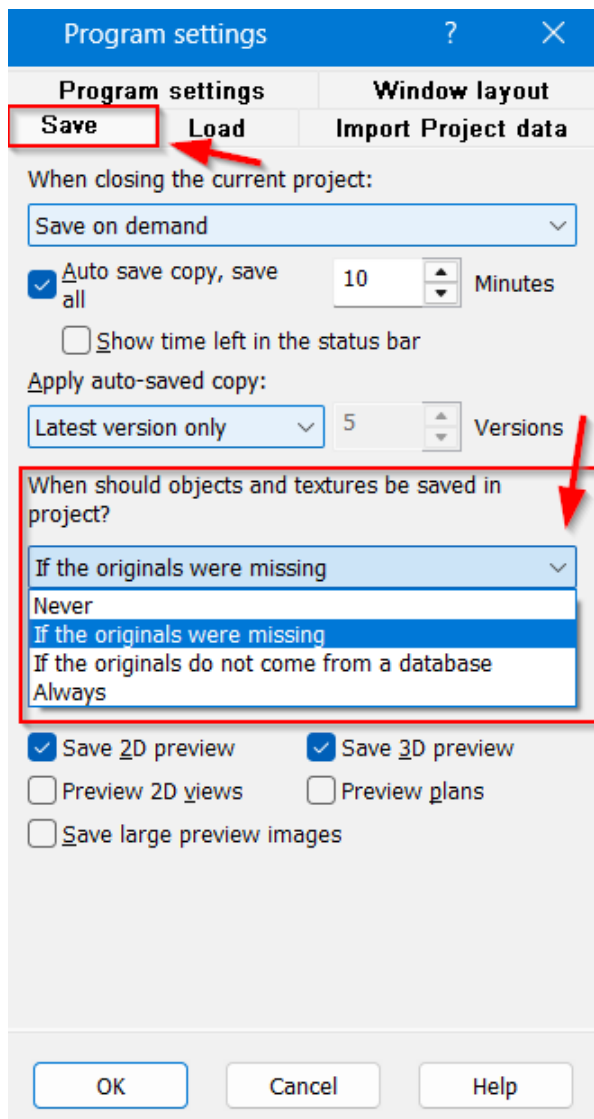

**Never:** No element is saved in the file. As a result, all elements that cannot be found in your databases and are not located in directories on your computer (for all elements that do not originate from databases) will be missing the next time the file is opened. This setting is useful for cleaning up files with many references that have been passed on by another editor, the file size is reduced and all elements still present can be found in the local databases. **But beware, data will be lost with this setting.**

**If the originals are missing:** Default setting. Only the elements that are inserted into the project on another workstation but cannot be found in your databases are saved. This setting has no effect on files that were only edited on your workstation.

**If the originals do not come from the database:** The elements are saved in exactly the same way as in the variant described above, but all elements that do not originate from databases (such as an imported 3D object) are also included in the project file.

**Always:** All elements are saved in the project file. This setting is not recommended, use the **Share** command for this .

### 3.3.3 Summary of the settings for loading and saving

These parameters are important as soon as project files are passed on and the databases on the two workstations are not the same.

Normal saving is sufficient for editing on one workstation.

If the project has been completed and is to be archived or the file is to be transferred to another office, use the **Transfer** function.

The following settings are recommended:

When saving **If the originals** are missing

When loading **If the originals are not found**

If you use the other settings, it is recommended that you create a backup copy of the source file before editing.

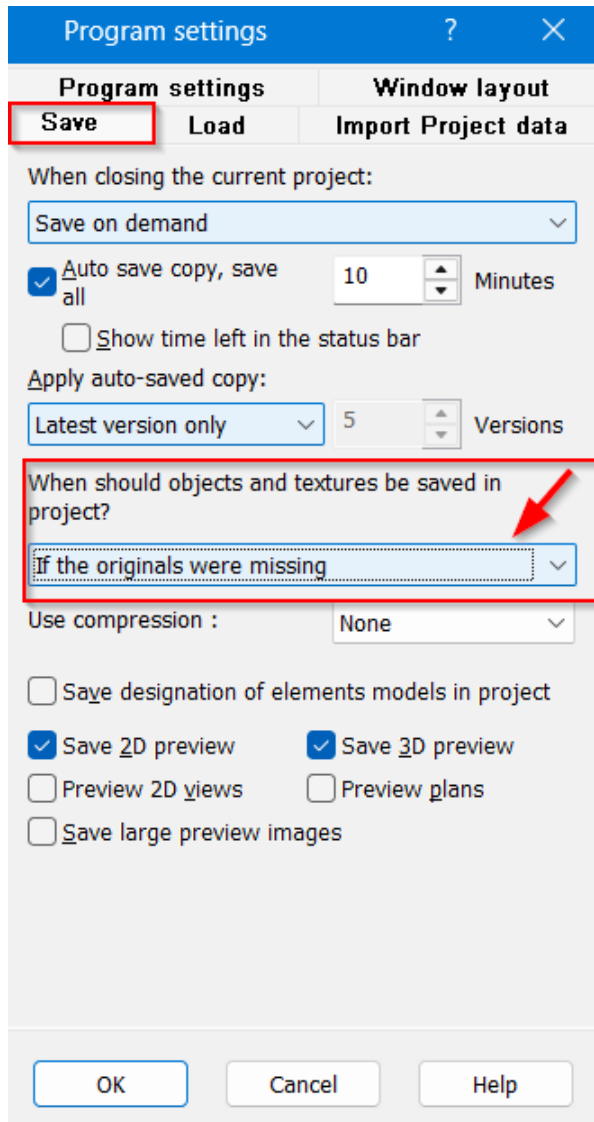

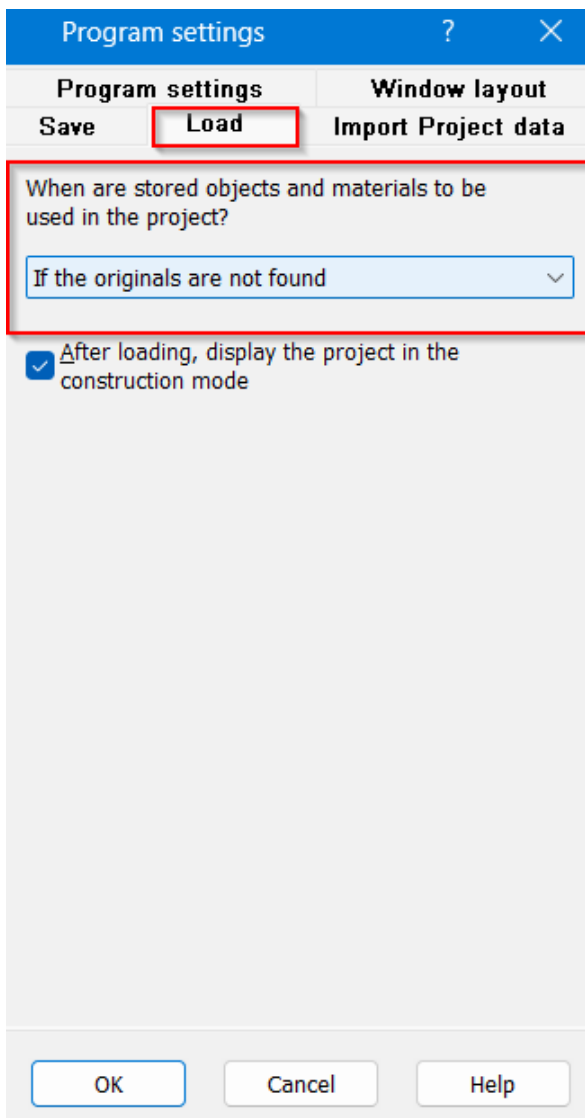

### 3.3.4 Program settings

You can find the program settings in the menu bar under **Options|Program. ...** **Select** here whether no file, a new file or the last edited file should be loaded after the program starts.

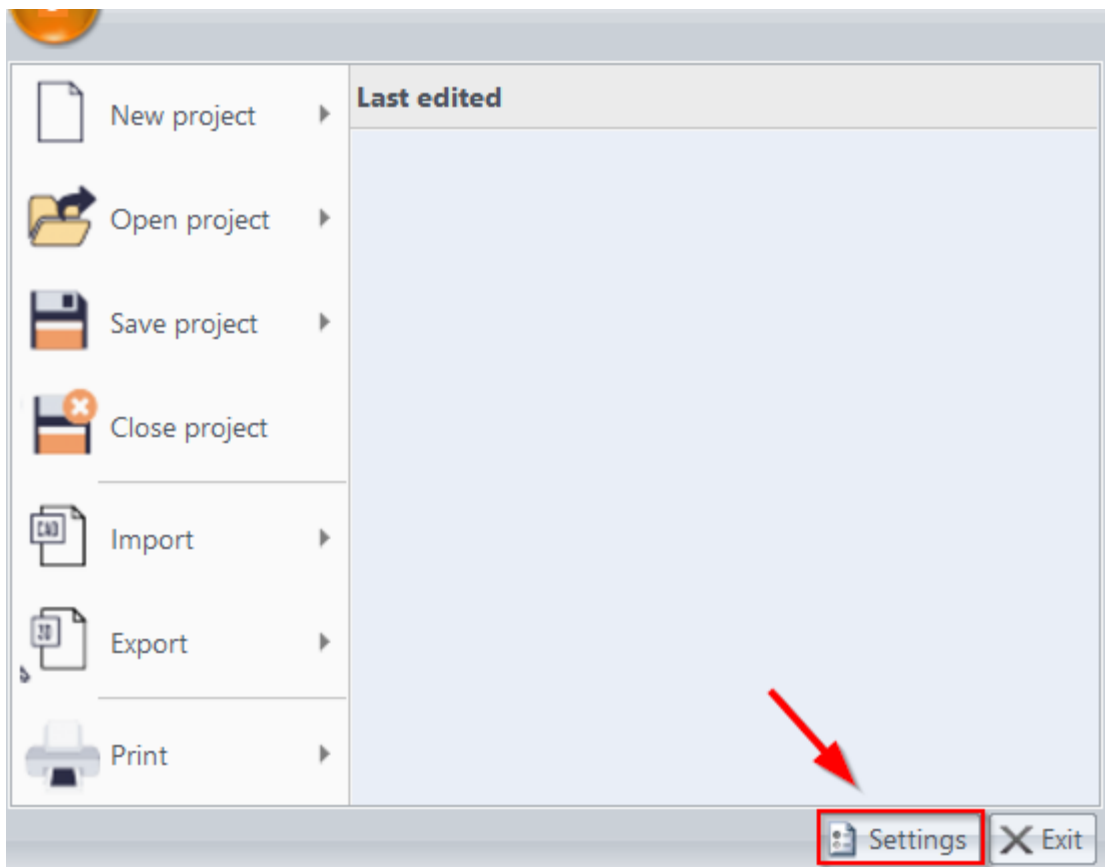

In the **Program settings** tab, use the drop-down field to select what should happen **when** the program starts:

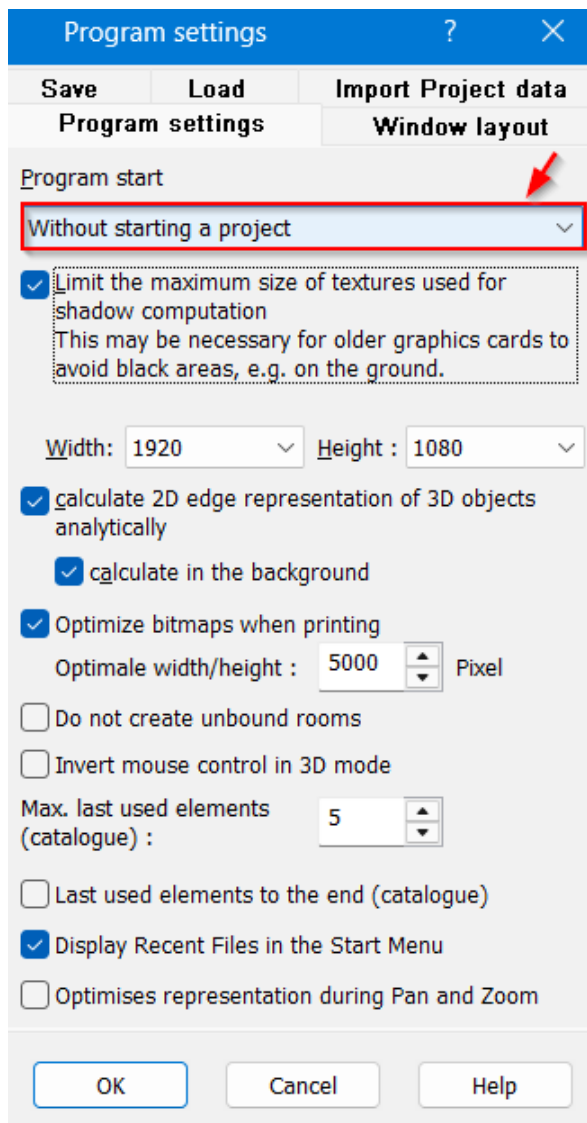

The following options are available:

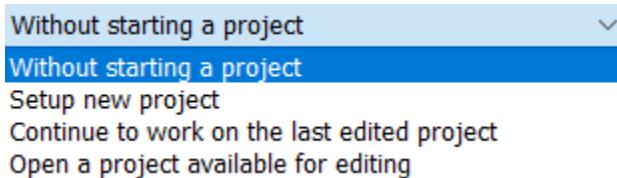

**Start without project:** Opens an empty program interface

**Create a new project:** Opens a new project file

**Continue working on the last edited project:** Automatically opens the last project

**Open an existing project for editing:** Automatically opens your default project folder

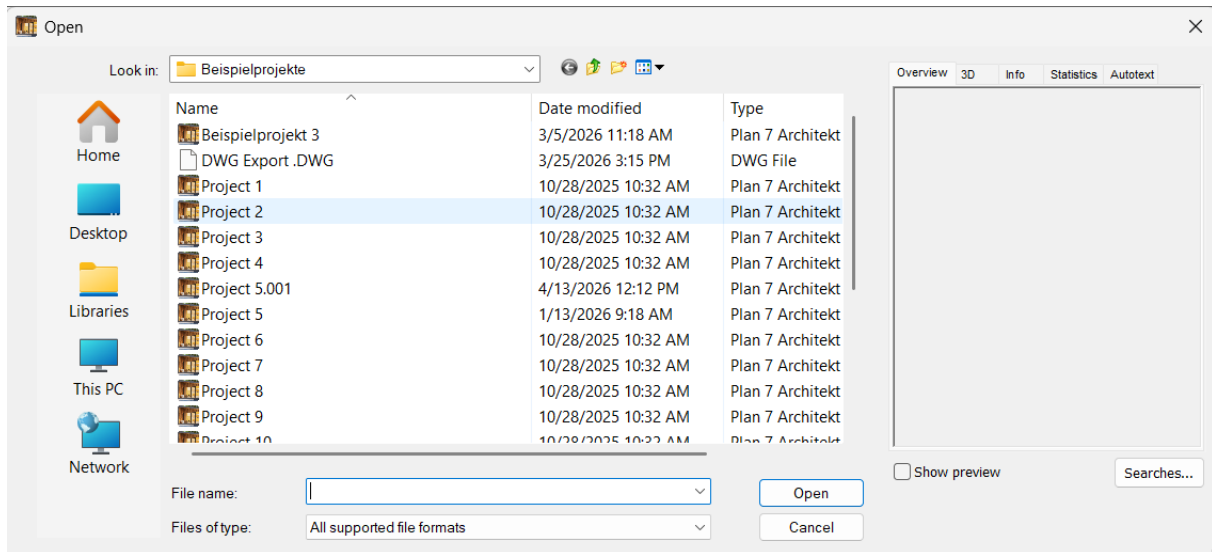

### Show recently used files in the start menu

Accessing server drives may take longer than accessing local storage media.

As a result, the listing of recently opened projects in the file menu can cause unpleasant waiting times.

This is particularly undesirable,

if no project is actually to be opened but another function, e.g. import, is required from the file menu. To

shorten these loading times, the corresponding option can now be set in the Settings dialog.

### 3.3.5 Creating or changing the standard.cad

The **standard.cad** is the template file that is read in with a new project when the program is started.

It contains all project properties that do not relate to the components or catalogs.

The standard.cad can be found in the **Templates\Program folder** Plan7Architect\ and can be adapted and revised as required.

Several different standard file can be stored in this **Templates** folder (for example, if you work for different clients).

A new project should then be opened with the setting:

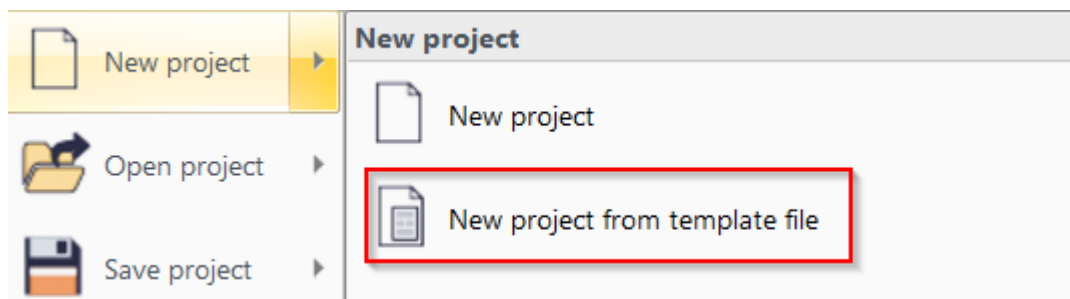

Examples of the contents of **standard.cad** are:

- \* Surface settings
- \* Settings for storey and layer management
- \* Settings under 'View', 'Project', 'Options'
- \* Settings under '2D views', 'Plans'

The template folder is also used to manage sample houses that are to be loaded and modified.

## 3.4 Print

The selection is made via the menu item **File|Print..**

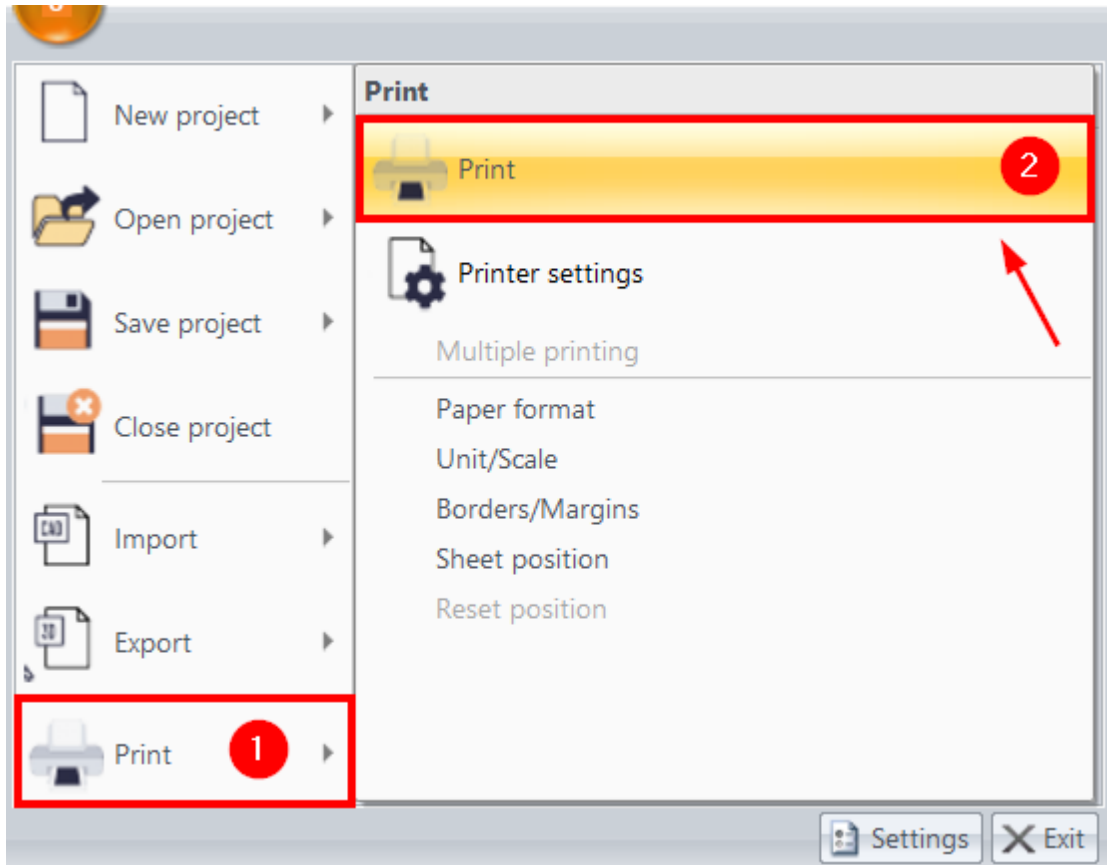

In Plan7Architect you can print from any mode.

This means that floor plans can be printed directly in construction mode and terrain mode, the current view in the 2D views and the perspective in 3D mode. The project settings for scale and sheet format apply to all four modes. All plan layouts of the project are managed in Plans mode. Each layout can have different scale and sheet format settings from the project.

### Printing in the Construction, Terrain and 2D views modes

Select the paper format in the **Print|Paper format** menu or under **File|Print|Paper format**. Also note the values for the side margins.

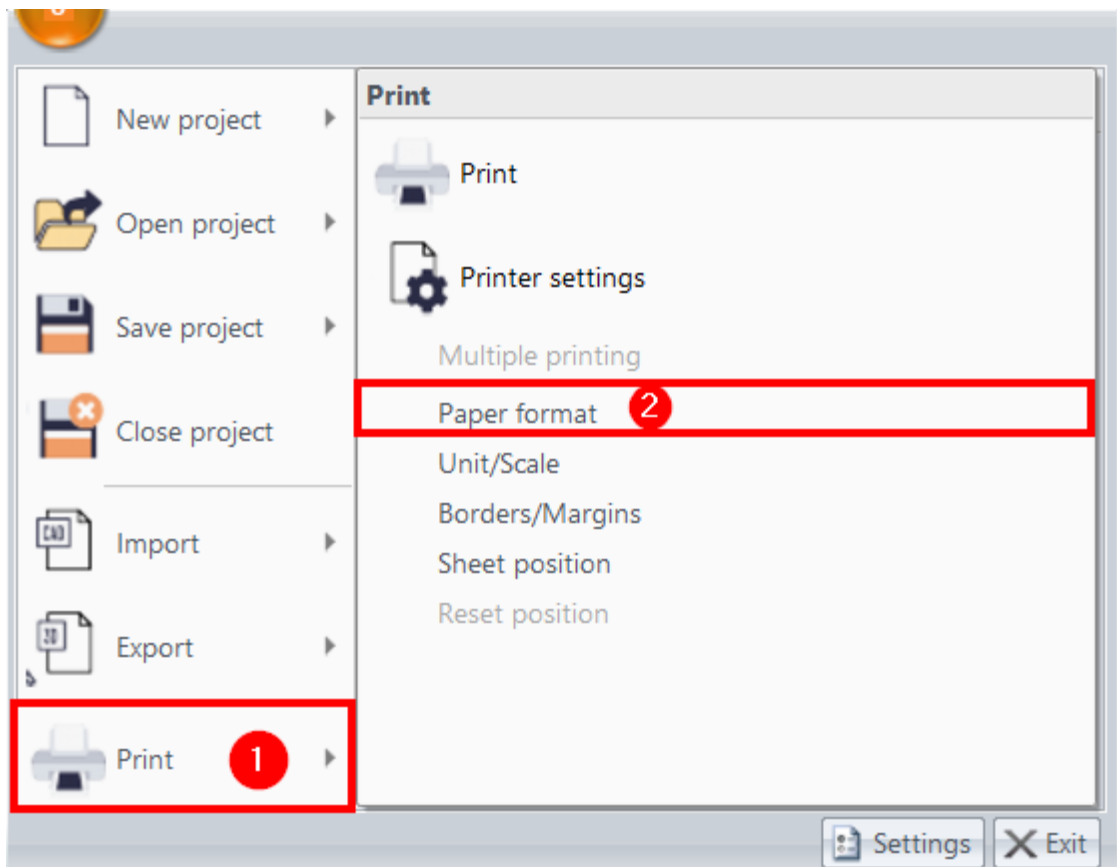
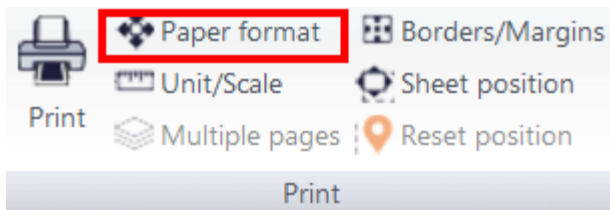

You will also find the settings for **scale/unit** in this menu.

Select the appropriate scale.

Close the dialog and switch to the **View|Position sheet** menu.

You can now define the position of the print area; the **W key** varies the insertion point. The position of the print area is the same for the Construction and Terrain modes; for the 2D views mode, the position must be selected separately for each view.

In the **View** menu, the sheet margin can always be made visible with the **Show margins** menu item. The **Multiple pages** option in the **View** menu shows the layout on the paper size specified by the current printer.

Please note that the Construction and Terrain modes use the same settings, but each 2D view has its own parameters.

### Printing in Plans mode

The procedure is similar to printing in construction mode, but the sheet format and output scale are selected separately for each plan layout.

The scale can also vary for each plan part. The position of the print area is also defined separately for each plan layout in the **View|Position sheet** menu.

### Printing in 3D mode

Of course, no scale can be defined in 3D mode. The sheet format is taken from the project properties. Further options for printing the 3D view can be found in the following section **Options|Print tab Printout of 3D view**.

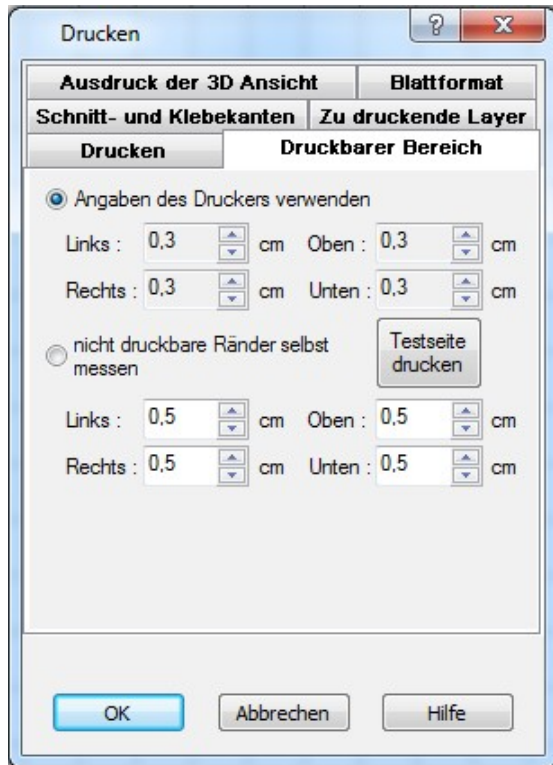

### Print tab

In this tab, you can set whether the print scale should automatically adapt to the selected paper format. The printout is scaled as large as possible to the set paper format.

### Printable area

Almost every printer or plotter cannot print right up to the edges of the paper. These distances of the non-printable area depend on the respective output device. In the **Printable area** tab, you can set whether this information is taken from the printer driver or set individually. Individual settings are necessary if your printer does not provide any values or the print result is incorrect.

### Layers to be printed

Select which layers are to be printed. The default setting is to include all visible layers. The print result thus corresponds to the screen display and can best be checked before printing.

### Cut and glued edges

Gluing multi-page printouts together is made easier by using gluing and cutting edges. Specify the width and height of the gluing and cutting areas. Optionally, the cut edges can be numbered consecutively. Adjacent cut edges are given the same number.

### Sheet format

Select the desired paper format for the printout in the selection list.

The width, height and margins are displayed in the corresponding input fields. The orientation of the printout can be set to portrait or landscape format.

The DIN formats from A6 to A0 are permanently stored. There is also the setting **as printer** (= the current paper format of the current printer).

If you change the dimensions of the paper format, the **Custom** entry is set. These individual settings can be saved under a name using the **Define** button.

The list of individually created paper formats is saved in the **Paper formats.ini** file in the program directory.

#### **Printout of the 3D view**

The **white background** option causes the printout of the 3D window to be created without a background. This applies to colors and images.

The quality of the printout can be set in the **Resolution** selection list.

## 4 Basic knowledge

### 4.1 Surface

#### 4.1.1 The surface

In construction mode, the **program interface** is divided into the following **areas**:

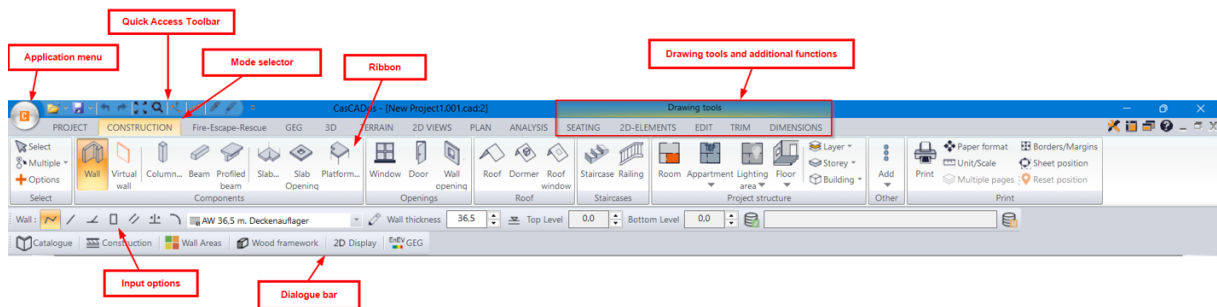

**View bar** for switching the most important display options on and off (the display depends on the selected level of detail):

1 2 3 4 5 6 7 8 9 10 11 12 13 14 15



1 Display hatching

2 Display fillings

3 Display line thickness

4 Display line patterns

5 Switch labeling of elements on/off

6 Show texts

7 Show dimensioning

8 Show external dimensioning

9 Show properties

10 Show item numbers

11 Show master data

12 Show auxiliary elements

13 Cut-outs

14 Show roofs

15 Wooden construction (hide/display/exclude)

16 Show terrain

17 Further display settings

The respective function is **active** if it is highlighted in yellow/orange, e.g:

Hatchings are displayed in the project (prerequisite: level of detail medium/fine):

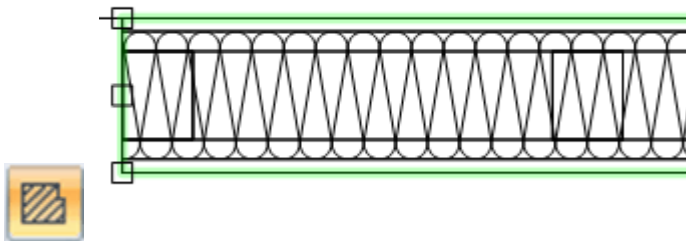

Hatchings are **not** displayed in the project:

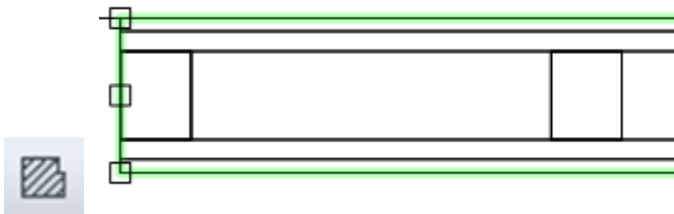

If a new element is drawn or an existing one is selected, the most important properties of this element type are displayed in the dialog bar.

In addition, all property dialogs are listed in the dialog bar.

The changes in property dialogs are always immediately applied and displayed in the drawing. If you want to undo a change, please use the undo function.

If you move the mouse over a drawn element, the element information is displayed in the status:

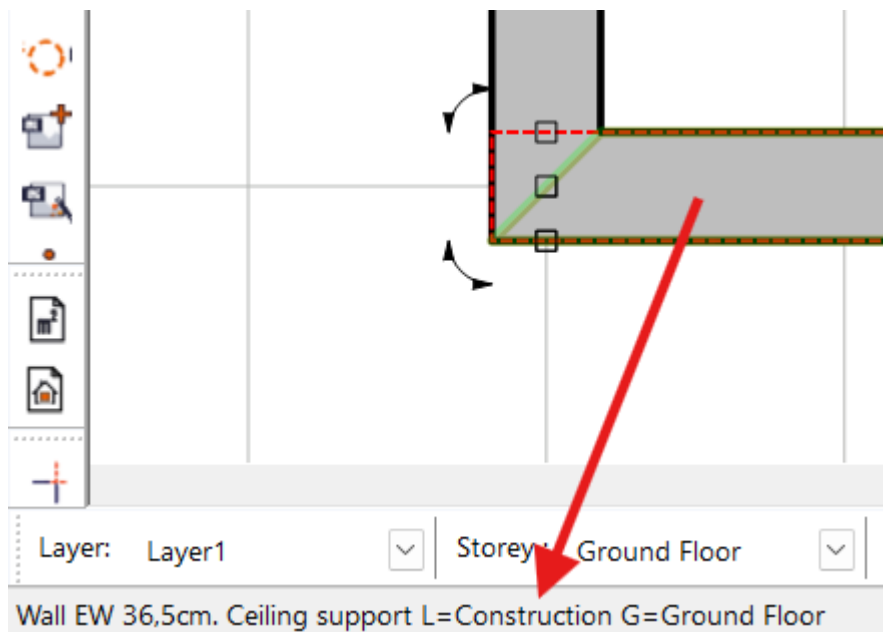

### 4.1.2 The modes

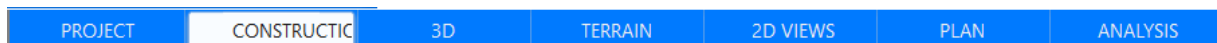

Plan7Architect is divided into eight modes. Each mode provides the user with the functions required for the respective planning process. This has the advantage that only the functions that are actually required are shown during processing, thus ensuring simple and clear operation.

The current mode can be selected in the standard bar using the corresponding button. If you change the current mode, nothing is changed in the planning; only the tools offered by the program and possibly the view of the project change (Construction shows the floor plan, 3D shows the 3D view, ...)

#### The Construction mode

mode displays the floor plan of your design. You are offered the functions for all components such as walls, windows, columns, etc. as well as 2D elements such as lines, texts, dimensions, etc.

You can place 3D objects and symbols in the plan.

#### The 3D mode

mode shows you the planning as a 3D perspective. In this mode, all components and 3D objects are shown, 2D elements are not visible. Functions for editing materials, the material explorer and the 3D object explorer are available.

Structural components can be selected in 3D mode and their properties can be changed.

#### The terrain mode

mode shows the planning in floor plan. In this mode, the terrain, the plot, terrain shapes and garden design are designed. However, all structural components can be edited without restriction.

#### The 2D views mode

mode creates views, sections and any other 2D drawings.

Views and sections can remain linked to the model and thus update themselves when changes are made to the planning.

#### The Plans mode

mode creates a plan from any project views (floor plans, views and sections, perspectives). 2D drawing elements can also be entered.

#### The Evaluation mode

mode almost combines measurements and project data and enables calculations to be made with these and output as reports.

### 4.1.3 Mouse operation

A conventional mouse with a scroll wheel is required to operate Plan7Architect.



The **left mouse button** activates the functions or function steps.

The **scroll** wheel (middle mouse button) is used for zooming and rotating, if CTRL is pressed at the same time, the screen can be moved

The **right mouse** button is used to call up an editing menu:

Paste	Ctrl+V,at+Delete
Don't snap	Ctrl+1
Snap on everything	Ctrl+2
✓ Snap on grid	Ctrl+3
✓ Snap on end points	Ctrl+4
✓ Snap on middle points	Ctrl+5
✓ Snap on corners	Ctrl+6
✓ Snap on cross sections	Ctrl+7
✓ Snap on edges	Ctrl+8
✓ Rotate while moving	Ctrl+9
✓ Snap to sides	
Don't snap now!	F3
Close Element	Alt+C
Undo the last step	
Complete the element	
Cancel function	

If you want to end a function step, press the **ESC** key once  
If you press the **ESC** key twice ,the entire function is terminated.

The function can also be ended by clicking with the left mouse button on this symbol  **Selekt** at the top left under Selection.



#### 4.1.4 Edit

To change the selected elements, click **Edit** in the ribbon bar:

The commands are described in the manual in the Edit chapter.

Editing functions are available in the context menu (accessible with the right mouse button).

**Rotate** (context menu):

- **-45°**
- **45°**
- **90°**
- **180°**
- **270°**
- **Degree input...**
- **Free**
- **Free (with center)**

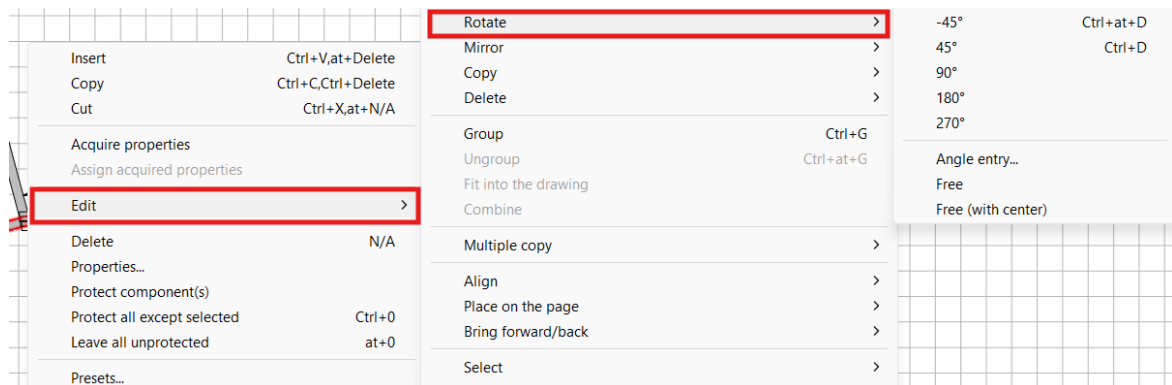

**Mirror** (context menu):

- **Horizontal**
- **Vertical**
- **Any axis**

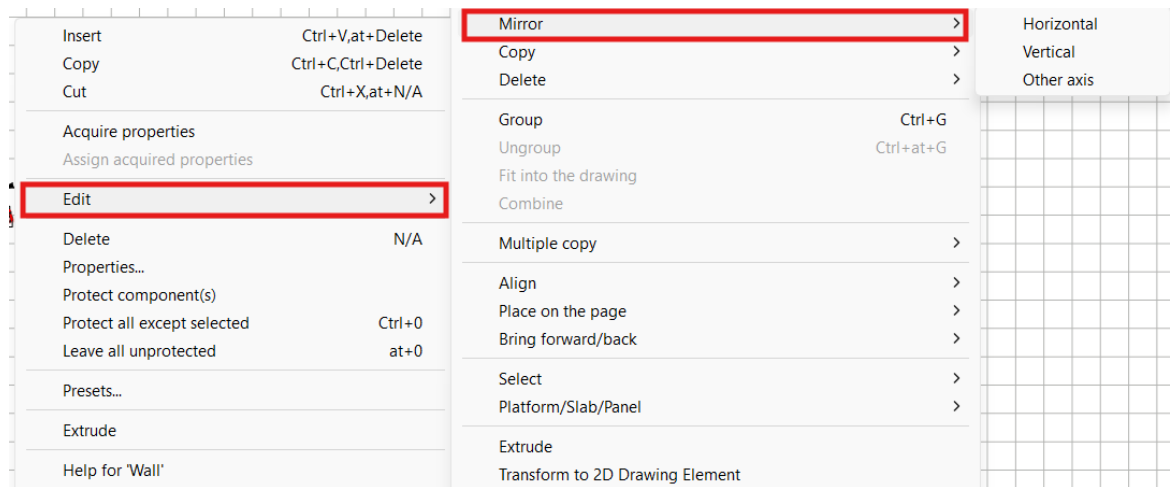

**Copy** (context menu ):

- **Copy offset**
- **Copy**
- **Copy to another storey...**

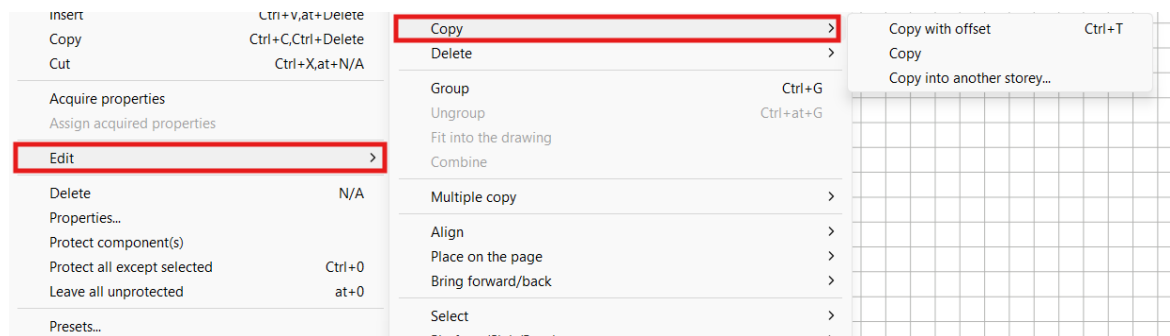

The command **Copy|Copy into** another storey... opens a window with a drop-down menu. The desired storey can now be selected here:

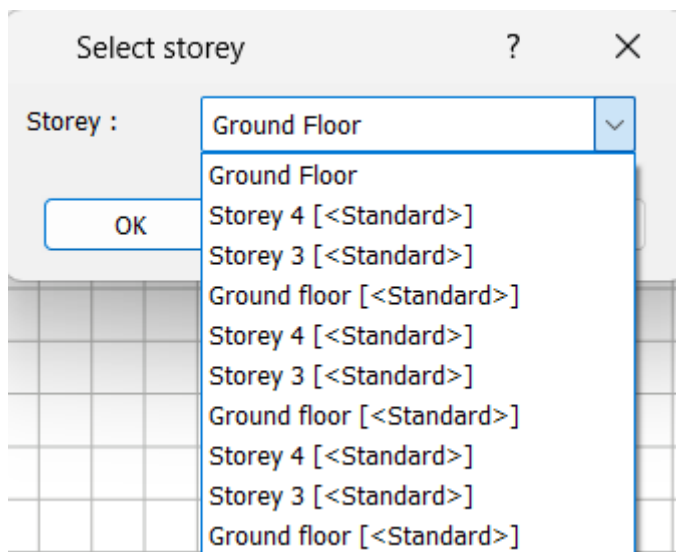

**Delete** (context menu):

- **All**
- **Active layer**
- **Other layer...**
- **Active storey**
- **Other projectile...**
- **Group...**
- **Selection**

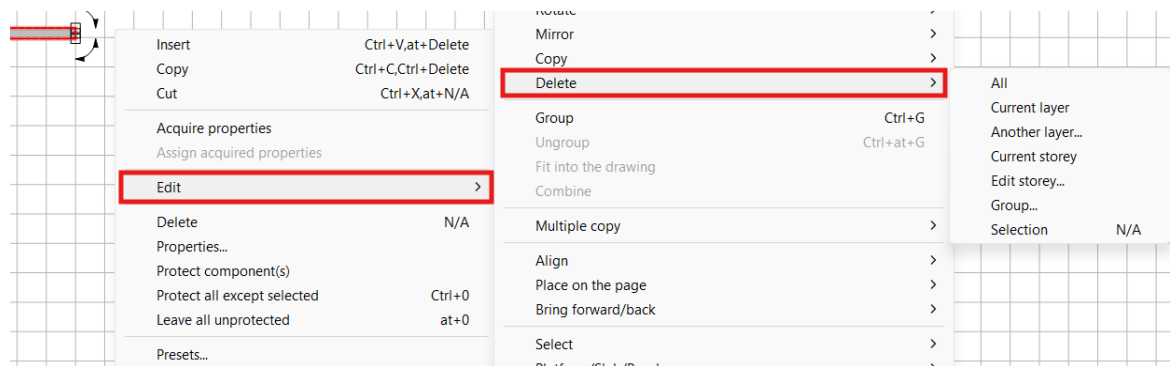

The commands **Delete|Other layer...** and **Delete|Other Story...** and **Delete|Group...** each ran a selection field with all layers/floors/groups of the project, here the layers/floors/groups to be deleted can be selected, a multiple selection is possible with **CTRL+left mouse button**:

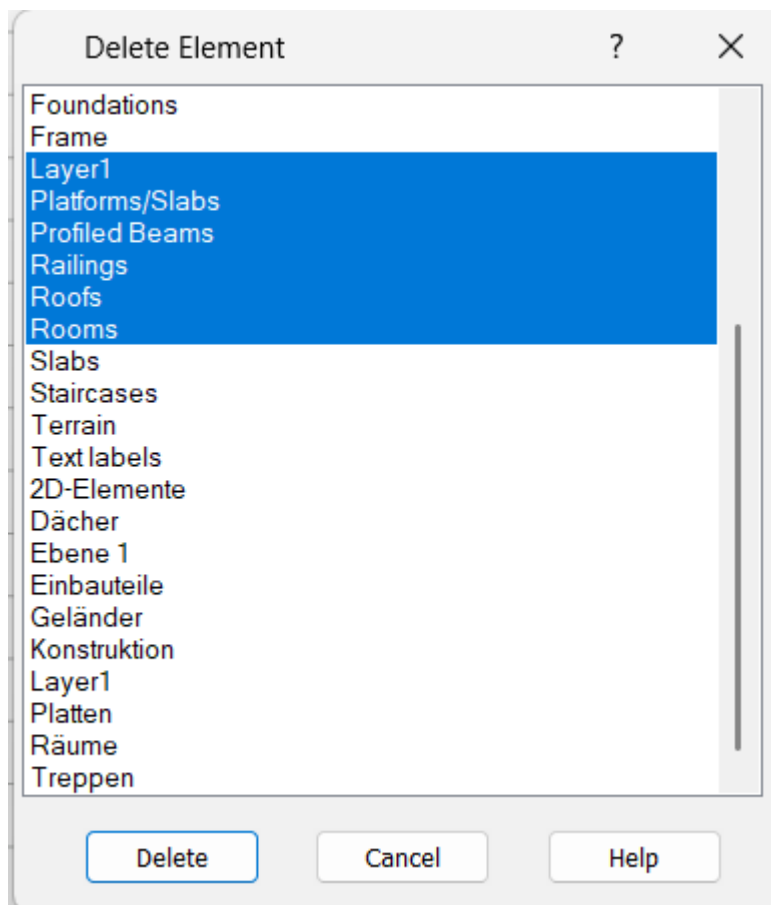

**Multiple copy** (context menu):

- **Linear**
- **Linear with spacing**
- **Matrix**
- **Radial**
- **Rotate**

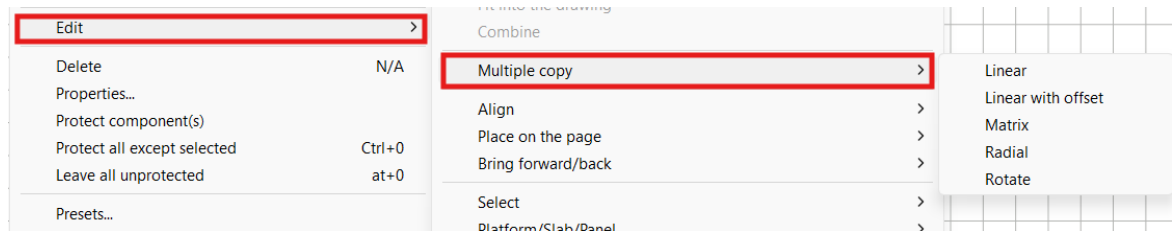
**Align** (context menu):

- **Left**
- **Right**
- **Top**
- **Bottom**
- **Center**
- **Horizontal**
- **Vertical**

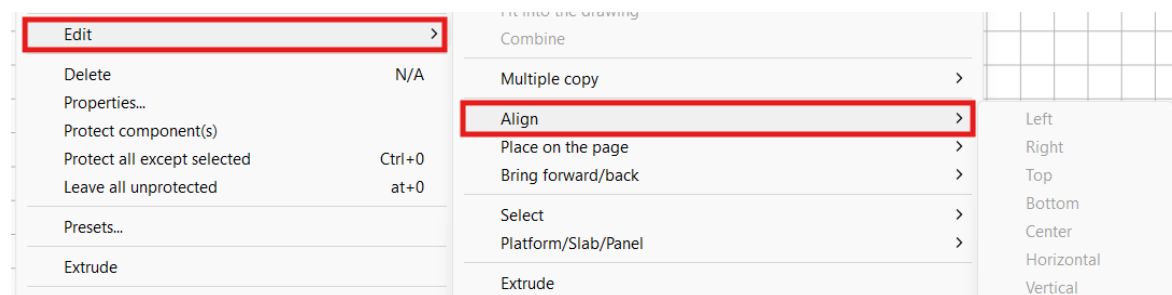
**Place on the page** (context menu):

- **Left**
- **Right**
- **Top**
- **Bottom**
- **Center**
- **Center horizontally**
- **Center vertically**

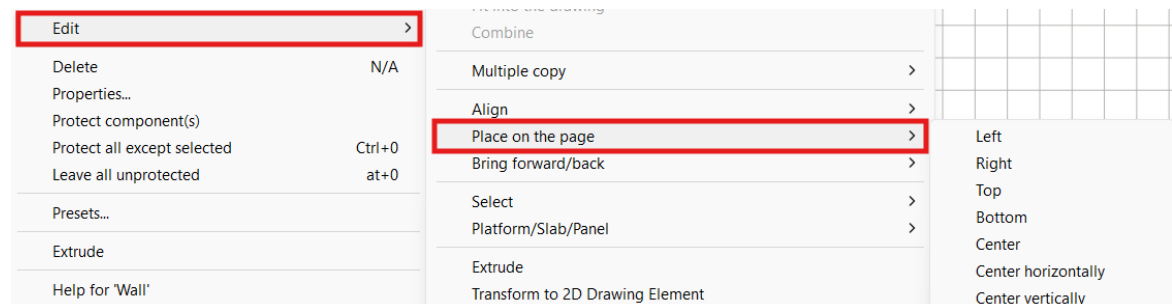

**Bring forward/back** (context menu):

- **Bring to the foreground**
- **Bring one to the front**
- **Move to the background**
- **Move one to the back**

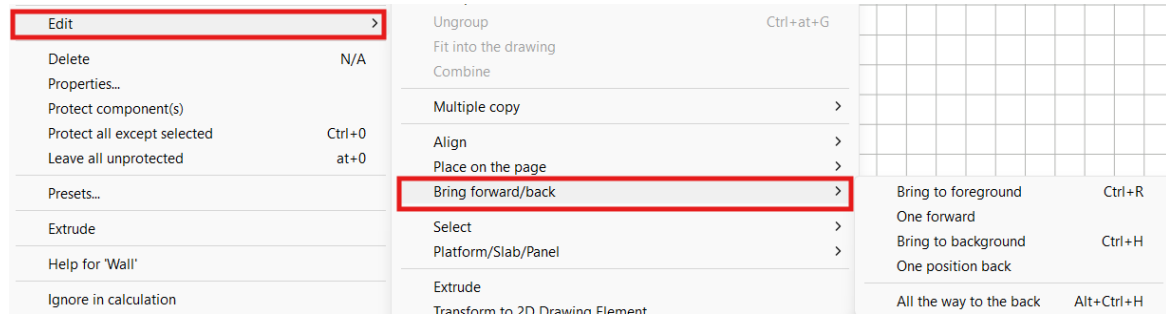

**Select** (context menu):

- **All**
- **Active layer**
- **Other layer...**
- **Active projectile**
- **Other projectile...**
- **Group...**
- **Unmark**
- **Invert selection**

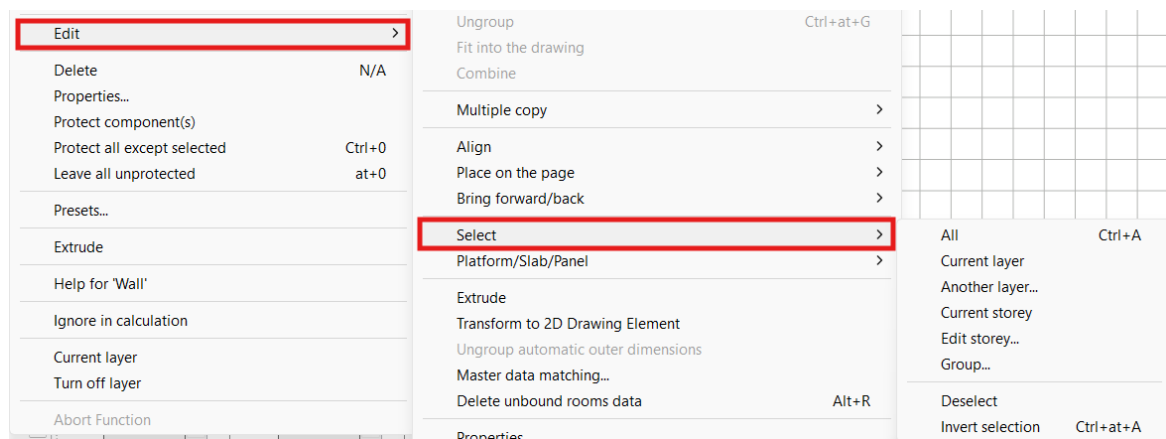

The commands **Mark|Other layer...** and **Mark|Other Story...** and **Select|Group...** each ran a selection box with all layers/floors/groups of the project, here the layers/floors/groups to be marked can be selected, a multiple selection is possible with **CTRL+left mouse button**:

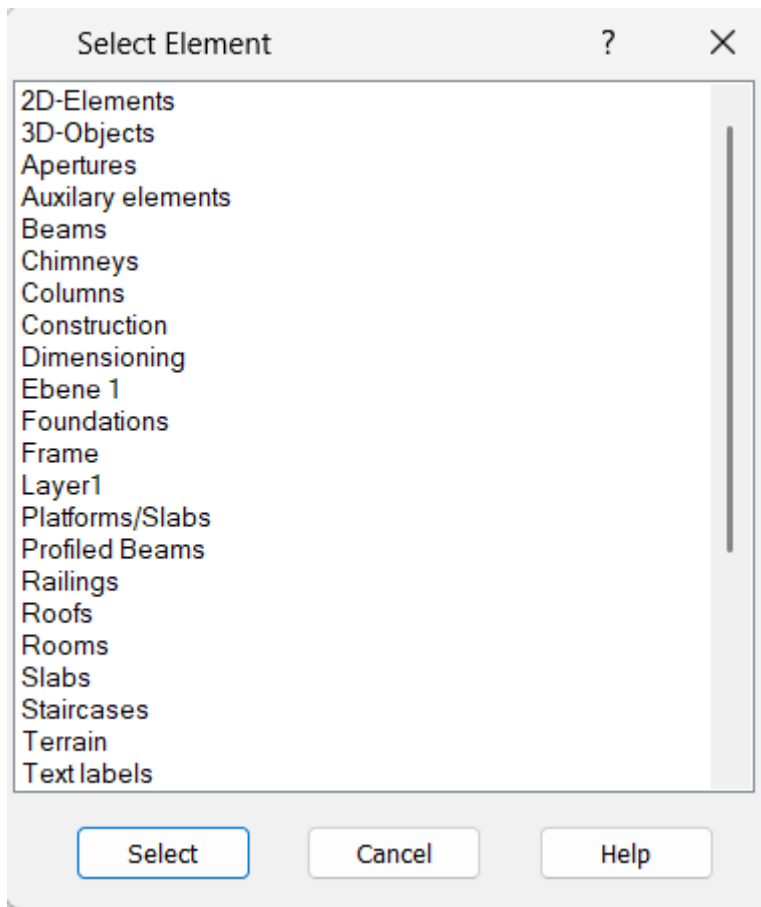

The command in the menu bar **Edit** **Convert to 2D drawing elements** causes the selected component to be displayed in the construction view, but is not visible in the 3D view:

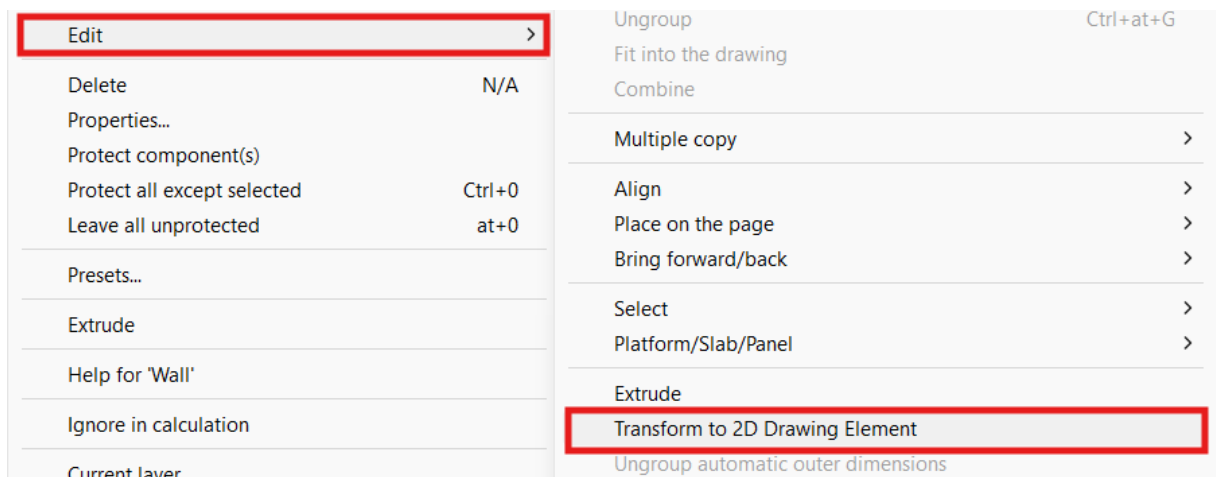

The command in the **Edit** **Delete Unbound Spaces** menu can be used to delete the unbound spaces of a project.

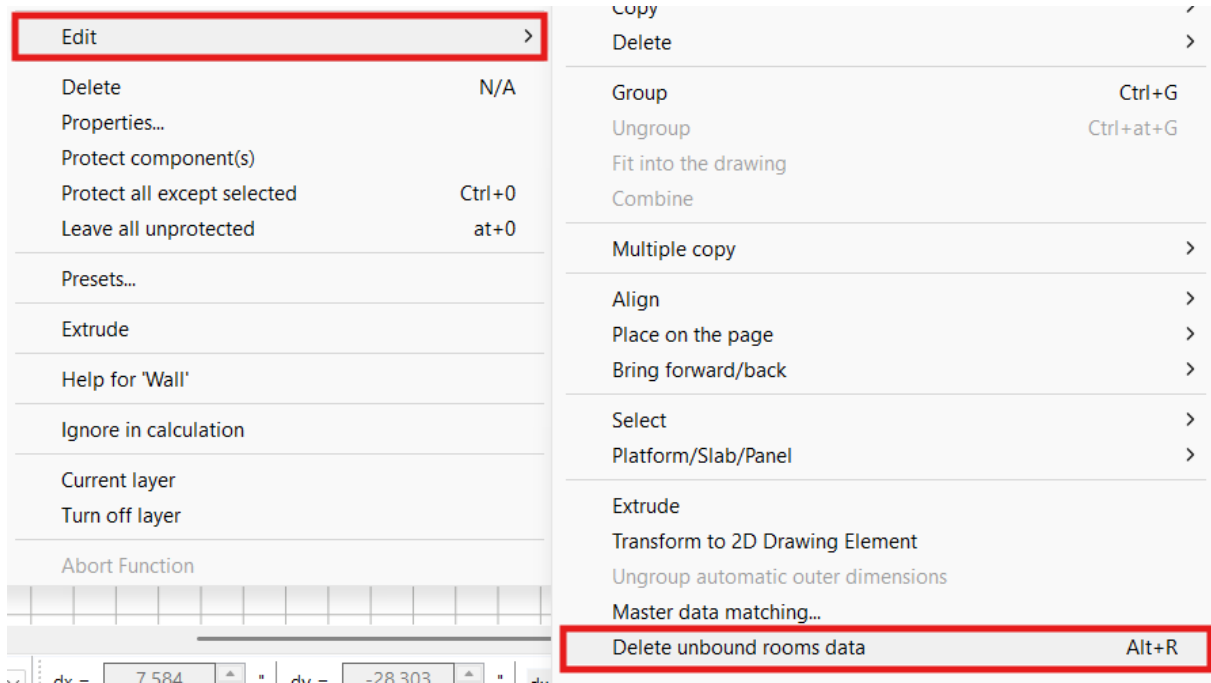

With the command in the **Edit** *Properties...* menu, all property settings for a previously selected component can be called up:

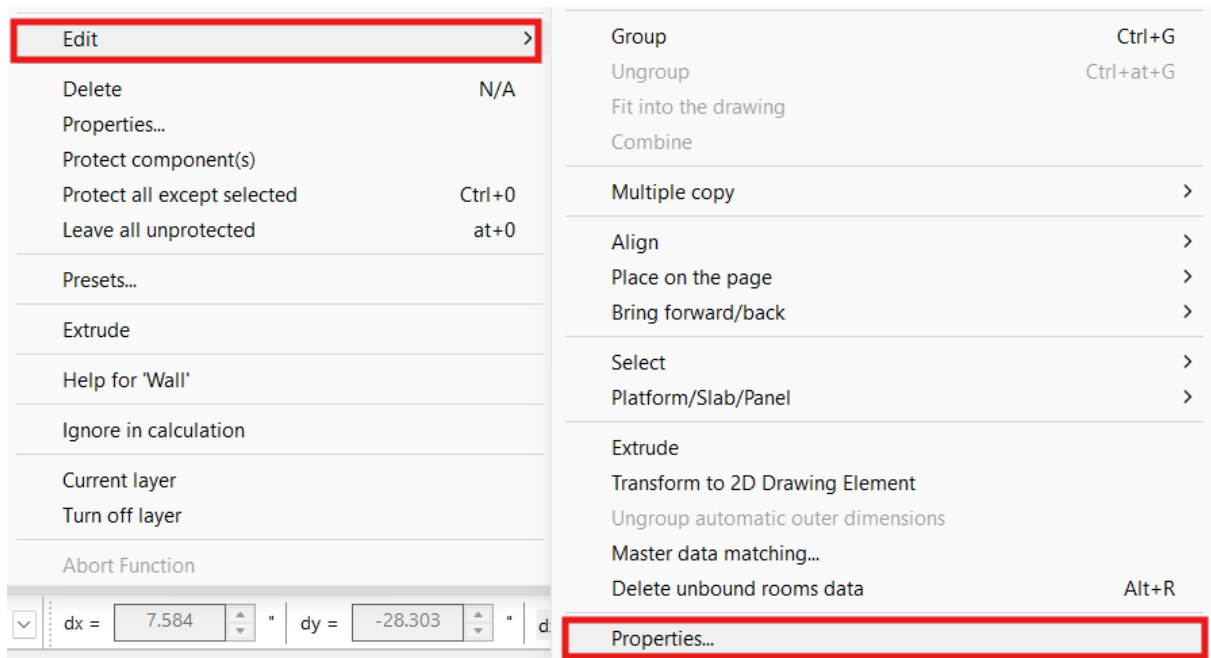

#### 4.1.4.1 Protect component

The **Edit** *Protect component(s)* command can be used to protect an element previously selected with the left mouse button against unintentional deletion or moving, for example. With a protected element, the Delete, Paste, Copy and Cut commands are not active.

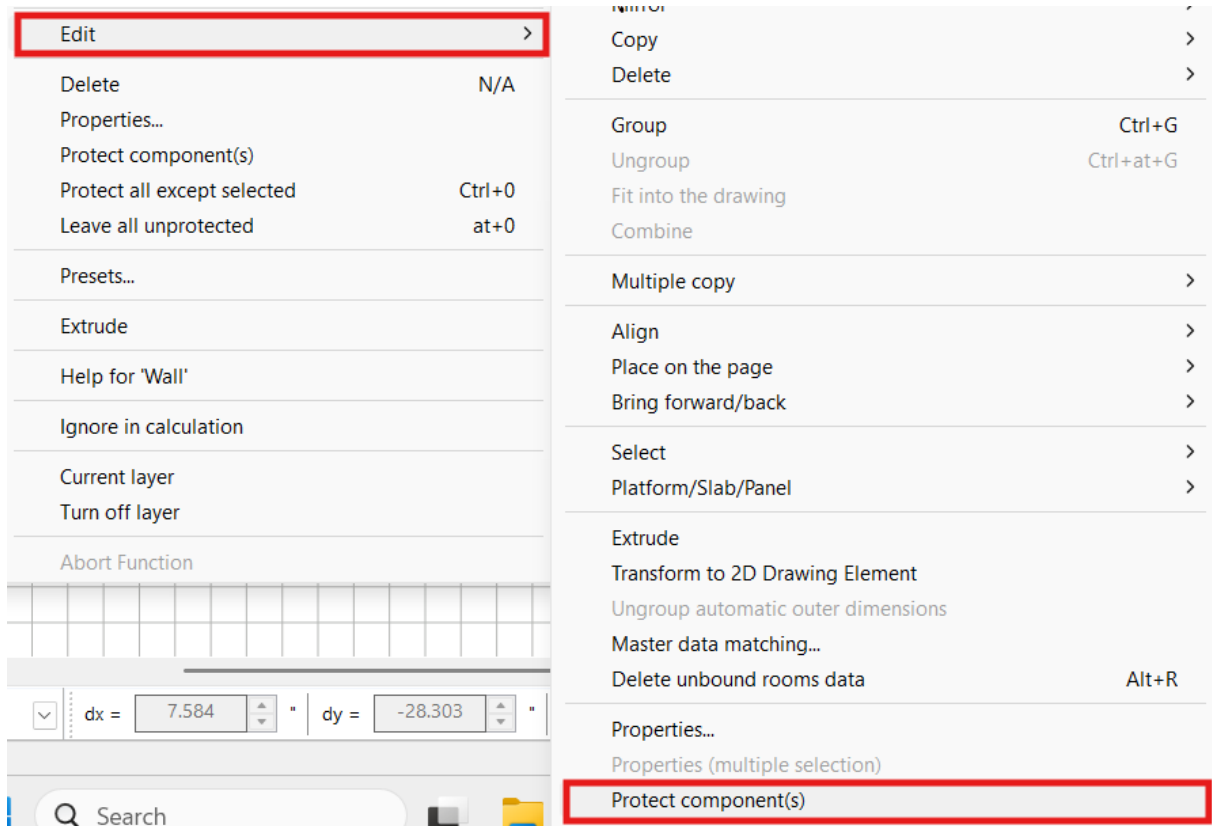

A protected element is displayed in a lighter color in the construction view. In this example, the eastern wall section of the kitchen has been protected:

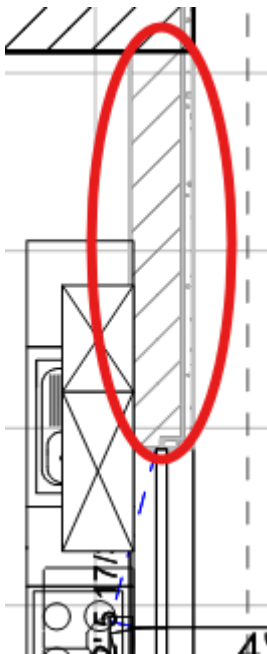

If the protected element is selected, it is displayed normally again and a check mark is placed behind the entry in the **EditProtect component(s)** menu. If you want to remove the component protection, click on the entry to remove the checkmark and the element can be edited again as normal.

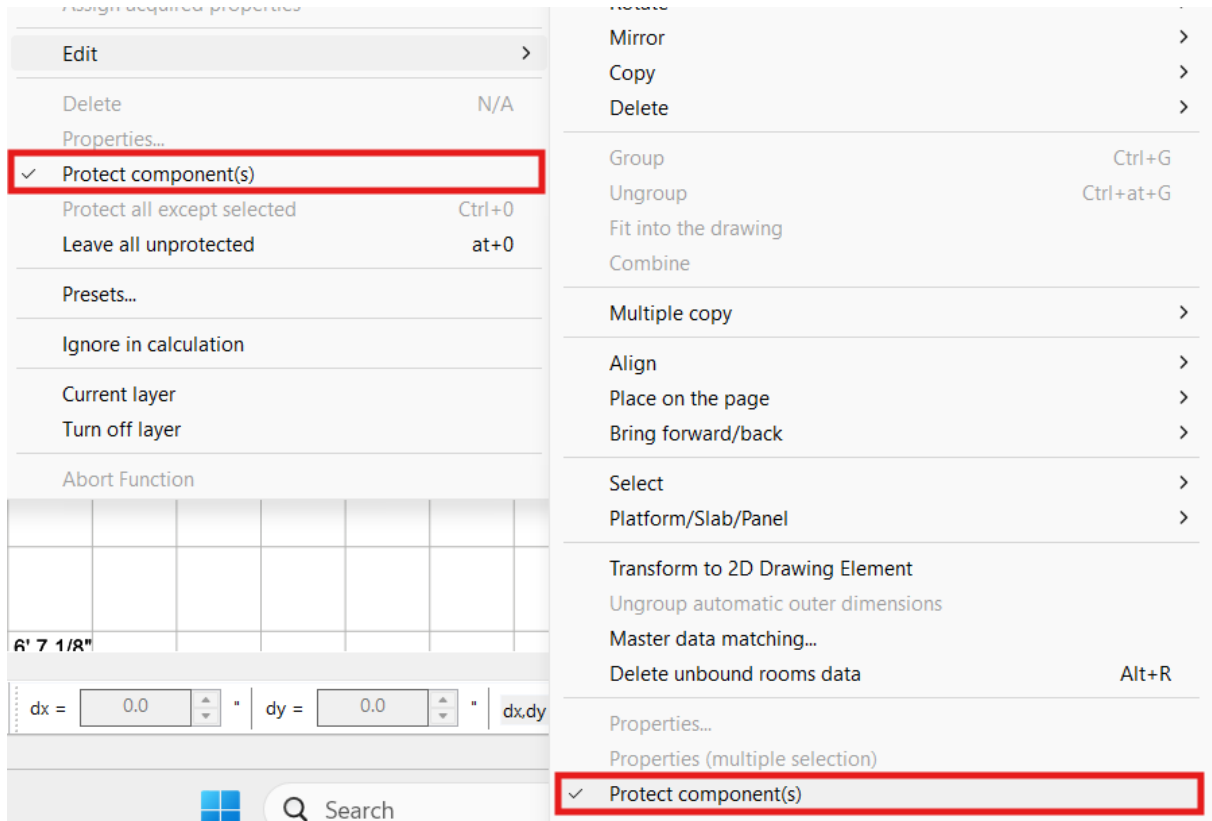

### All elements unprotected

Protect component(s)	
Protect all except selected	Ctrl+0
Leave all unprotected	at+0

Removes the element protection for all elements

### Protect all but selected elements

Protects all elements except the currently selected element. This function helps you with difficult edits.

If the selected element is a group, the content of the group can now be edited.

## 4.2 Coordinate systems

### 4.2.1 What are coordinates

Coordinates are an ordered set of values that indicate the exact absolute or relative position of an object in a coordinate system. A coordinate system is an orientation system that is used to define points in space or in the plane.

In order for graphic data to be saved in the form of alphanumeric values, all objects in a CAD drawing or graphic must be clearly defined in terms of both their size and their position on the drawing surface. For this purpose, Plan7Architect uses Cartesian or polar coordinate values; these are described in more detail below.

### 4.2.2 What do you need coordinates for?

You want to draw a wall in Plan7Architect that is exactly 2 meters long, not just approximately 2 meters long. A line should start exactly at a certain point, not just approximately.

This means that in order to meet this requirement, you must define points in Plan7Architect exactly.

You have two options for this:

1. entering coordinates
2. snapping existing points

Whenever an element point already exists at the desired coordinates, element snapping is the most efficient way to continue working on this point.

If no point exists yet, the exact coordinates required can only be entered via the coordinates window.

### 4.2.3 The Cartesian coordinate system

A **Cartesian coordinate system** is an orthogonal coordinate system whose coordinate lines are straight lines at a constant distance.

It is the most commonly used coordinate system, as it is the best way to describe geometric situations.

The horizontal axis is called the x-axis, abscissa or right axis. The vertical axis is called the y-axis, ordinate or vertical axis.

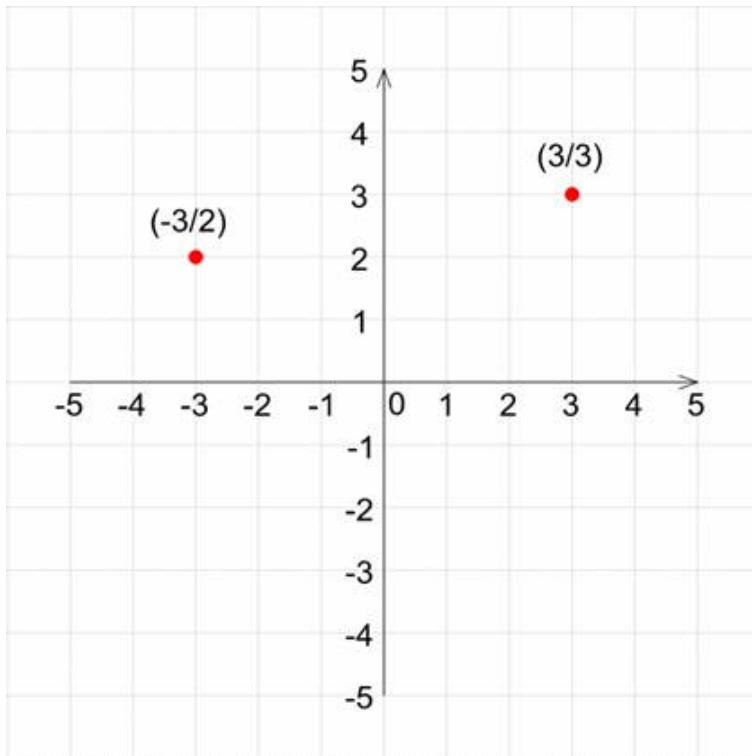

Flat (2-dimensional) Cartesian coordinate system

#### 4.2.4 The polar coordinate system

The circular coordinates of a point in the Euclidean plane are given in relation to a coordinate origin (a point in the plane) and a polar coordinate direction (a ray beginning at the coordinate origin).

The length of the imaginary line connecting a point  $P$  to the origin gives the distance coordinate  $l$ ; the counterclockwise angle  $a$  between the polar coordinate direction and the connecting line is the second coordinate. For a given coordinate origin and polar coordinate direction, the point  $P$  is therefore uniquely determined by  $l$  and  $a$ .

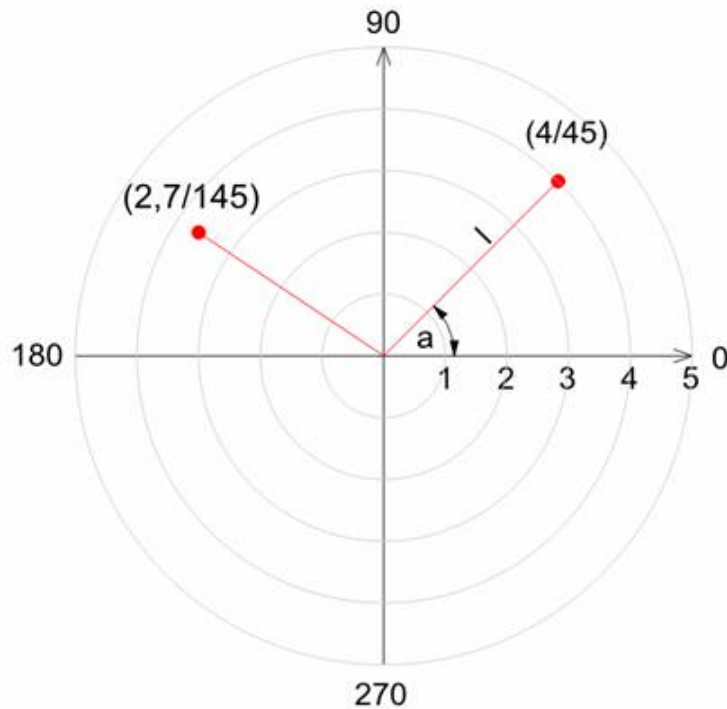

#### 4.2.5 Zero point

Each drawing has exactly one zero point, which applies to all levels and all storeys. This zero point is shown in the plan view with the black symbol .

The zero point is the  $X=0$  and  $Y=0$  value for the absolute coordinate systems, but it is also the origin of the grid.

Please note that views (in View mode) and plan layouts represent their own drawings and therefore also have their own absolute zero point.

Moving the absolute zero point

1. Click on the **Set zero point** button  in the coordinates window
2. The absolute zero point is attached to the crosshairs. Enter the position with the mouse or by entering coordinates.

#### 4.2.6 Operating point

The operating point is shown in the drawing with the symbol . All relative coordinate systems refer to this point during input.

The working point is always the last point drawn, see the examples below.

Moving the working point

1. Select the **Position** working point command  in the coordinates window
2. Click on the new position in the drawing field (also with snapping) or enter the desired coordinates.

## 4.2.7 dx, dy - relative Cartesian

The most commonly used coordinate system setting is relative Cartesian. (= standard setting). Cartesian coordinates are entered from the operating point.

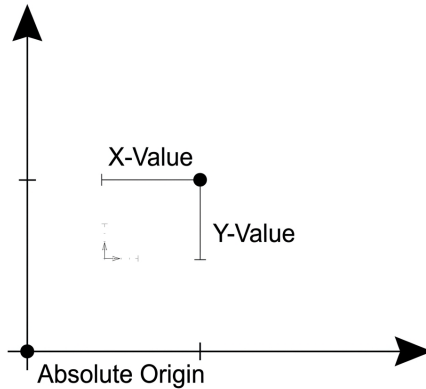

Example:

This example shows how to draw a line using relative Cartesian coordinates:

1. Note that the coordinate system is set to .
2. Click the Line button  in the construction bar and select the input type **Any line**.
3. Click anywhere in the drawing field to set the first point of the line
4. Now move the mouse cursor. The symbol for the working point is displayed on the first point of the line. The coordinate entries now refer to this point
5. To start the numerical coordinate input, press the **[Space]** key, the input field for the X value becomes active
6. Enter **100 cm**
7. Press the **[Enter]** key, the input field for the Y value becomes active
8. Enter **100 cm**
9. Press the **[Enter]** key, to complete the process

The result should look something like this:

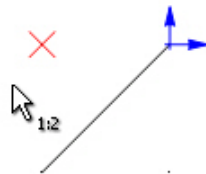

The working point is now the second point entered on the line. The Line command is still active, the system expects you to enter the first point of the next line. You can cancel the command with **[Esc]**.

### 4.2.8 x, y - absolute cartesian

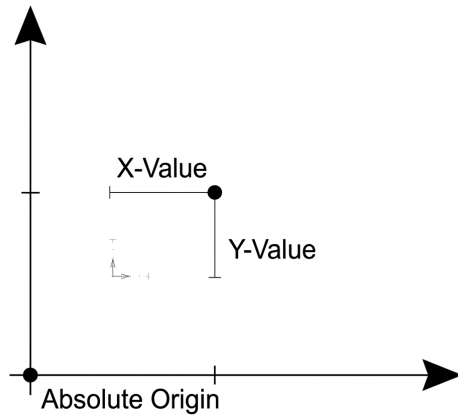



Absolute Cartesian coordinates are entered using two values, the X value and the Y value. Both values refer to the zero point of the project.

This coordinate system is well suited for transferring survey points to the planning, for example.

Example:

In this example, the two points of a line are entered with absolute Cartesian coordinates.

1. Set the coordinate system to **absolute Cartesian**
2. Click the Line button  in the construction bar and select the input type **Any line**.
3. Press the **[Space]** key, to start entering the coordinates. The focus changes to the X value of the position bar
4. Now pay attention to the unit of measurement used in the project and adjust the following units if necessary. All of the following information is in cm
5. Enter **400** for X and press **[Enter]**.
6. **0** is suggested, press **[Enter]** to confirm.
7. Now the second point, so press **[Space]** again to start entering the values.
8. And now **800**; **[Enter]** and **200**; **[Enter]**.
9. Press **[Esc]**, to end the **Draw line** command.
10. The line may not be visible in the current image section, so press  **Zoom Show all** in the standard bar



Pay particular attention to the position of the resulting line in relation to the zero point.

#### 4.2.9 dl, a - relative polar

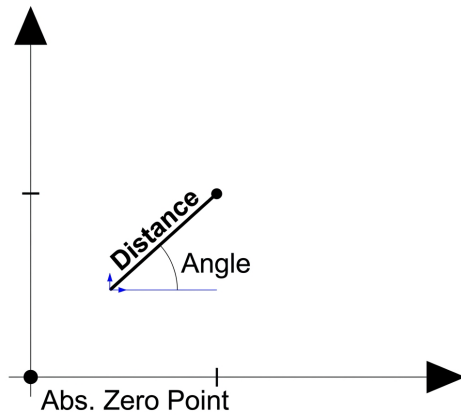

In this setting, the distance and angle are entered in relation to the operating point.

#### 4.2.10 l, a - absolute polar

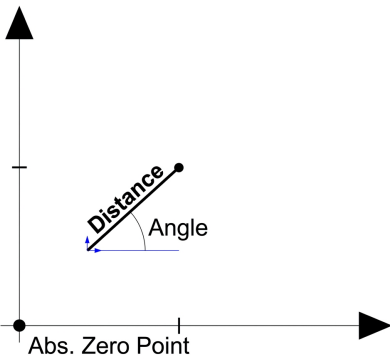

In this setting, the distance and angle are entered in relation to the zero point.

#### 4.2.11 dl - direction and distance

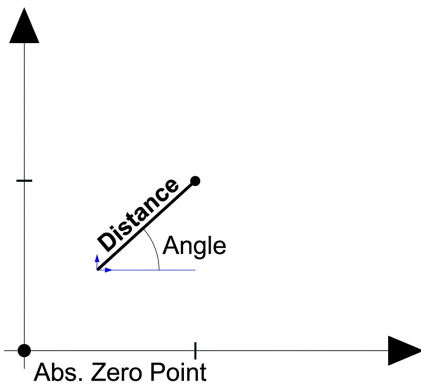

If this coordinate system is used, only the distance needs to be entered; the direction is taken from the current position of the mouse pointer.

Example:

In this example, a wall polygon is to be entered.

Snap directions for horizontal/vertical should be activated, see previous chapter Snap/Snap directions.

1. Select the coordinate input **direction/distance** in the position bar.
2. Select **Draw wall** in the construction bar.
3. Select the input **type polygonal**.
4. Start the input at any point.
5. The position of the wall axis can be varied using the **W** button.
6. Move the mouse to the right in the positive X direction.
7. Start entering the coordinates with the **[Space]** key.
8. Enter the value **1000** and press **[Enter]**.
9. Move the mouse down in the negative Y direction.
10. **[Space]** key
11. **800** and **[Enter]**
12. Press **[Esc]** to complete the entry.

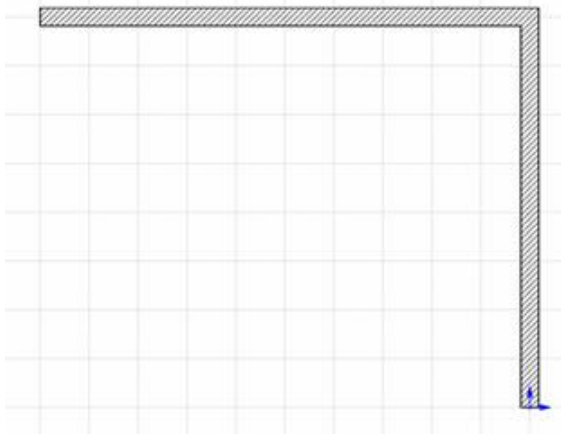

#### 4.2.12 Entering coordinates, further examples

##### Working point

During input, all relative coordinates always refer to the operating point. If this is converted, new possibilities arise.

Initial situation:

Draw any two lines, like this ...

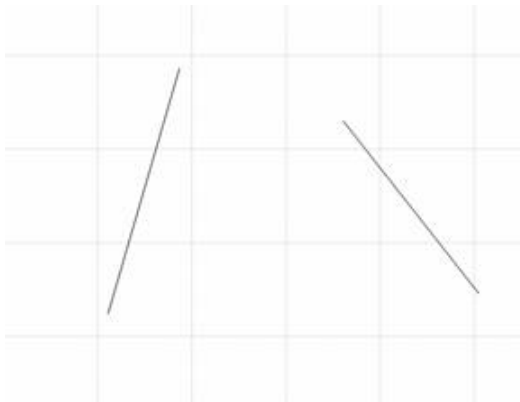

The task is now to draw a new line starting from the upper end point of the left line and ending exactly 50 cm to the left of the upper end point of the second line.

1. Enter the two lines
2. Set the coordinate system to ***dx,dy relative cartesian***
3. **Draw line** command in the construction bar
4. Snap the upper point of the first line
5. Set **B** as shortcut key for working point
6. Place the working point on the upper point of the second line. The coordinate entry starts automatically.
7. **-50** as X value, **[Enter]**
8. **[Enter]** (Confirms 0 in Y)

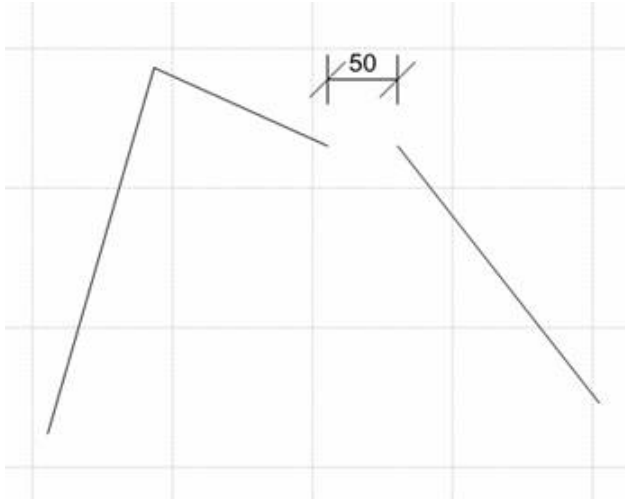

#### Rotating the coordinate system

The coordinate system can be rotated in two ways:

**a. Rotating the drawing grid**

Read chapter 8.3.1 Grid, Rotate section.

**b. Rotating the working direction**

## 4.3 The structure of projects

### Buildings - storeys - layers - zones

A project, whether small or large, should be recorded in a well-structured manner. This structure, provided it has been well thought out, simplifies editing and input, enables the design of printouts and, last but not least, increases clarity for the user.

The structure of a project is normally as follows:

- a **project** in Plan7Architect is divided into one or more **buildings**,
- a **building** in turn is divided into one or more **superimposed storeys**,
- a **storey** is divided into several **layers**.

Two buildings are shown in the following diagram. These buildings have three and two storeys. The first floor of building 1 is currently active (shown in green).

This floor in turn consists of several layers, one of which is also active.

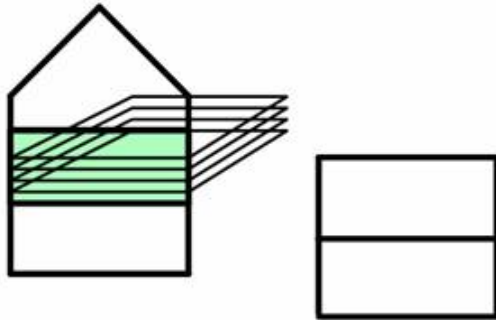

The floors of a building are always on top of each other. This means that any change to the storey heights of one storey also results in changes to the other storeys.

Every component that is drawn in Plan7Architect is always assigned to a layer and therefore also to a storey and a building. This assignment takes place either automatically - as with walls - or by selecting the current layer.

**Zones** are now the fourth structure in Plan7Architect and have no geometric equivalent, but are only assigned to rooms as an additional property.

It is irrelevant whether the rooms in a zone are in the same building or on the same floor.

### 4.3.1 Layer

In terms of handling, layers are comparable to highly transparent drawing paper. Any number of these layers can be placed on top of each other, but only the layer that is marked as the active layer is drawn on.

The active layer is displayed in the **Layer** selection list in the dialog bar.

Layers can be switched on and off, they are visible (when switched on) or invisible (when switched off). Furthermore, only the active layer or all existing layers can optionally be shown.

Open the layer management of your project via the button . A form opens with a list of all existing layers in this drawing.

Layers created by drawing elements with a fixed layer assignment are displayed in red. Free layers created by the user are black.

The active layer is indicated by the blue circle.

Layers can also be edited and managed in the **Layer** menu.

#### 4.3.1.1 What is the active layer?

Only one specific layer is always active, in this case **layer 1**. Everything that is drawn from now on is on this layer, unless it is an element with a fixed layer assignment. This is the case with walls, for example; walls are always on the **Construction** layer. The active layer must also be taken into account when selecting elements if "**All except active**" is selected in the **Protected layers** selection list. But more on this later.

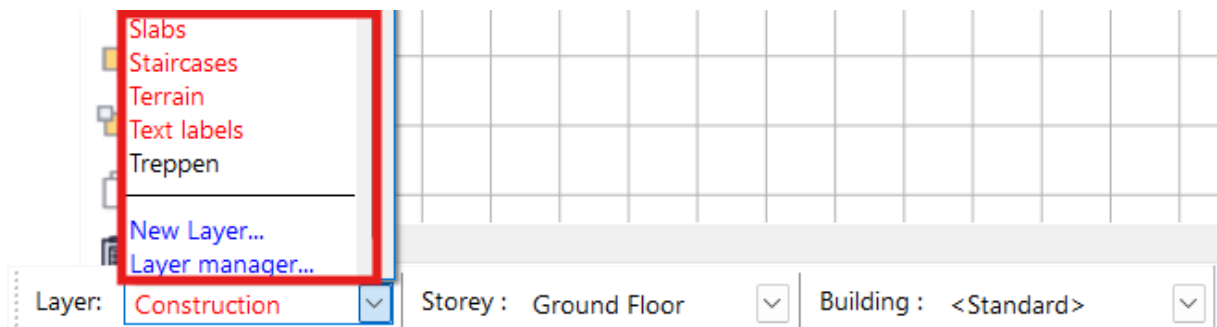
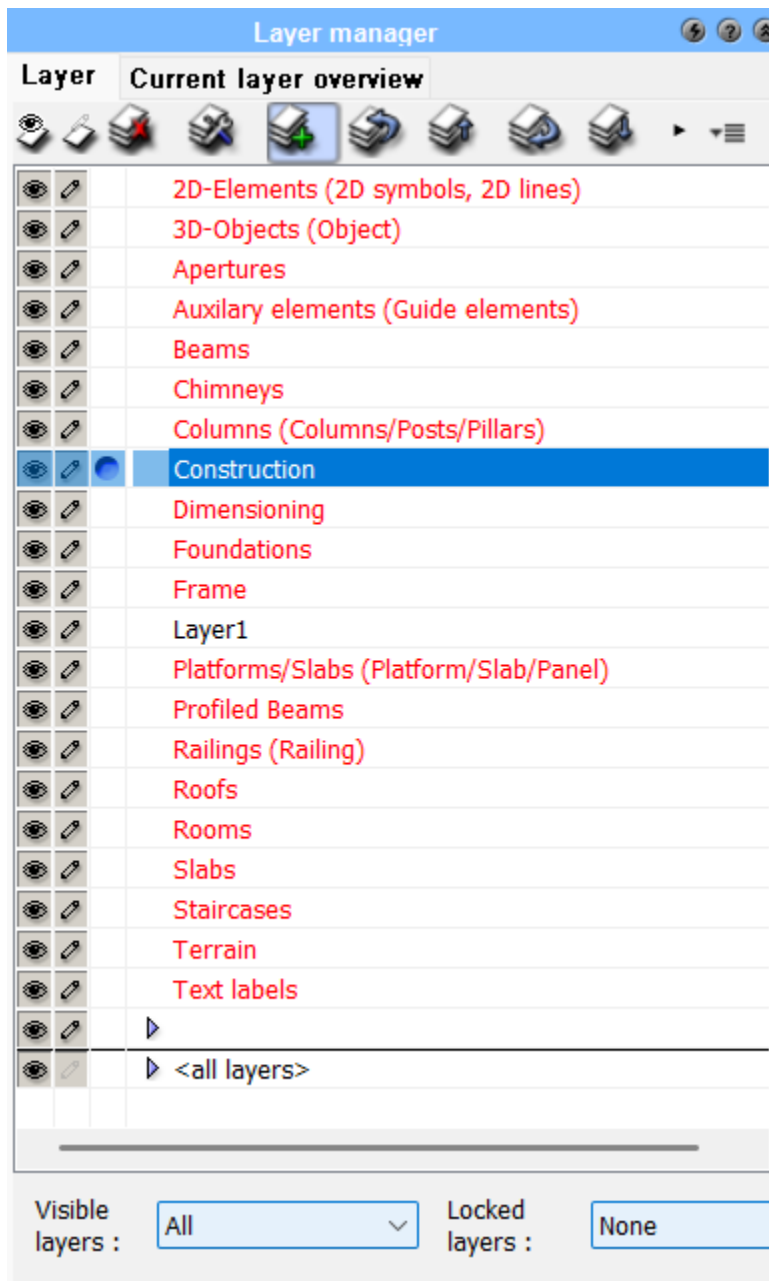

#### 4.3.1.2 Create a new layer

Click on the button  **Add new layer**.  
The new layer appears at the end of the list.

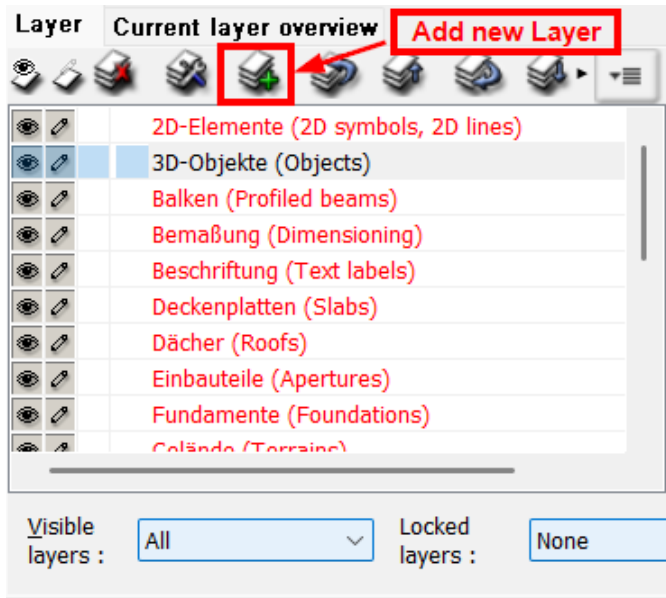

or via right-click:

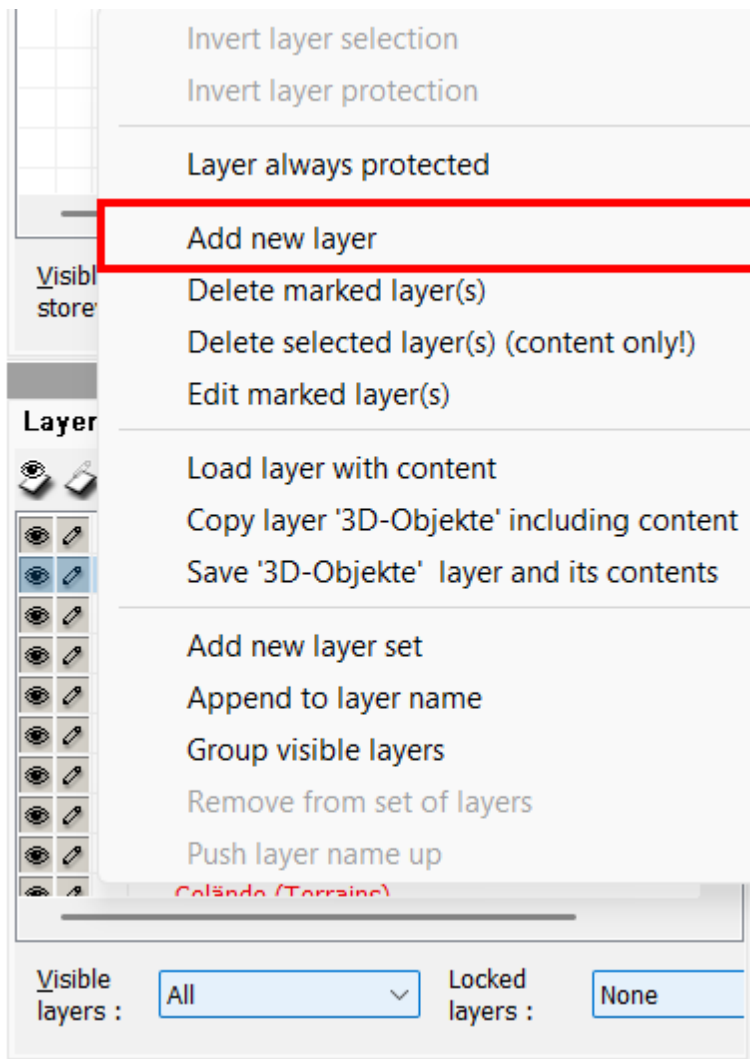

or via selection list Layer (bottom left):

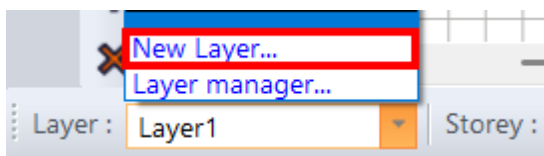

Enter the desired layer designation, select one or more additional designations for element types to be created on the layer if required and confirm with OK.

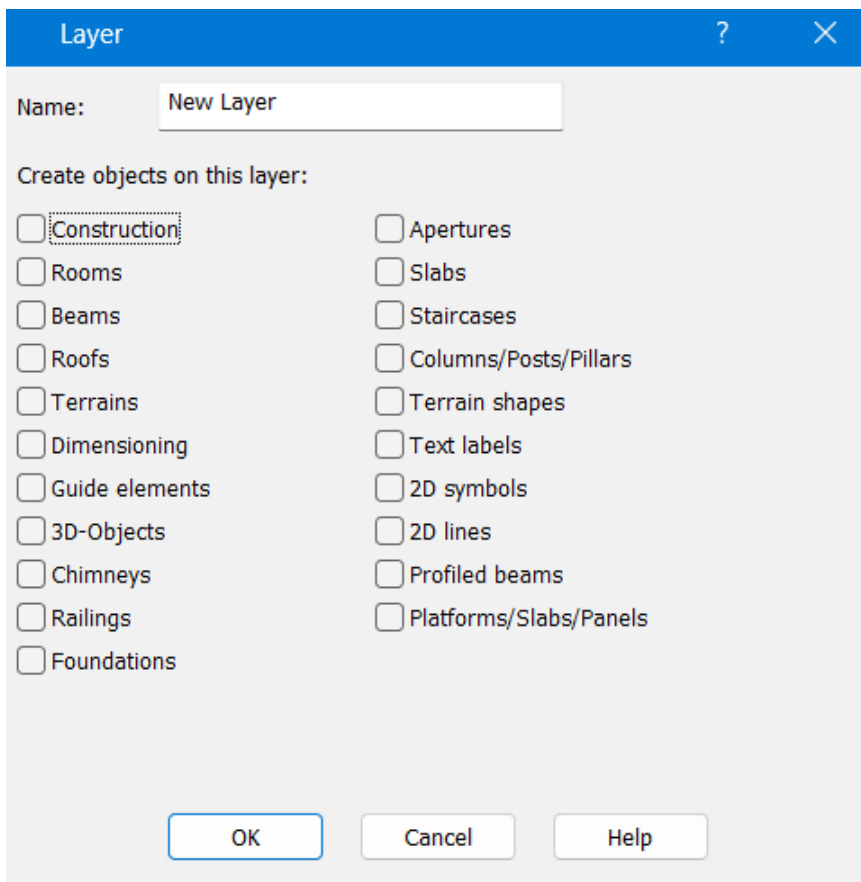

The newly created layer is now displayed in the list:

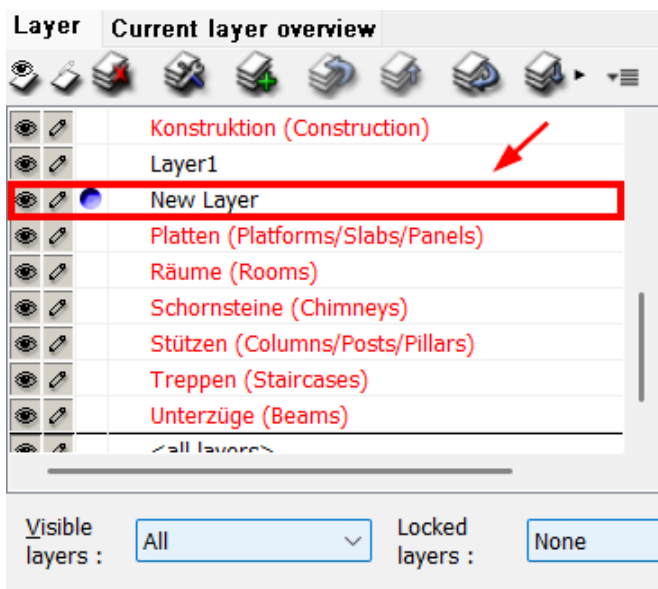

#### 4.3.1.3 Delete a layer

Use the mouse to select the line of the layer/several layers and click on the button  **Delete selected layer**.

The layers and all contained elements are deleted.

or use the mouse to select the row of a layer/several layers and right-click. You can now click on Delete selected layer(s).

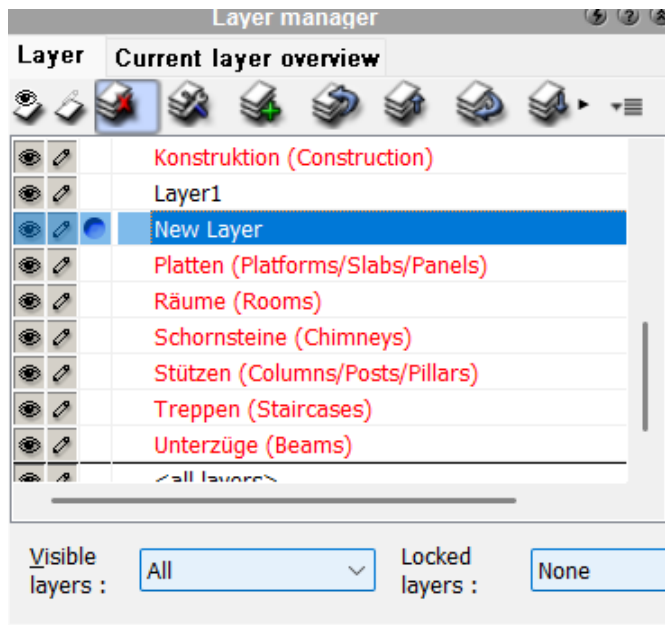

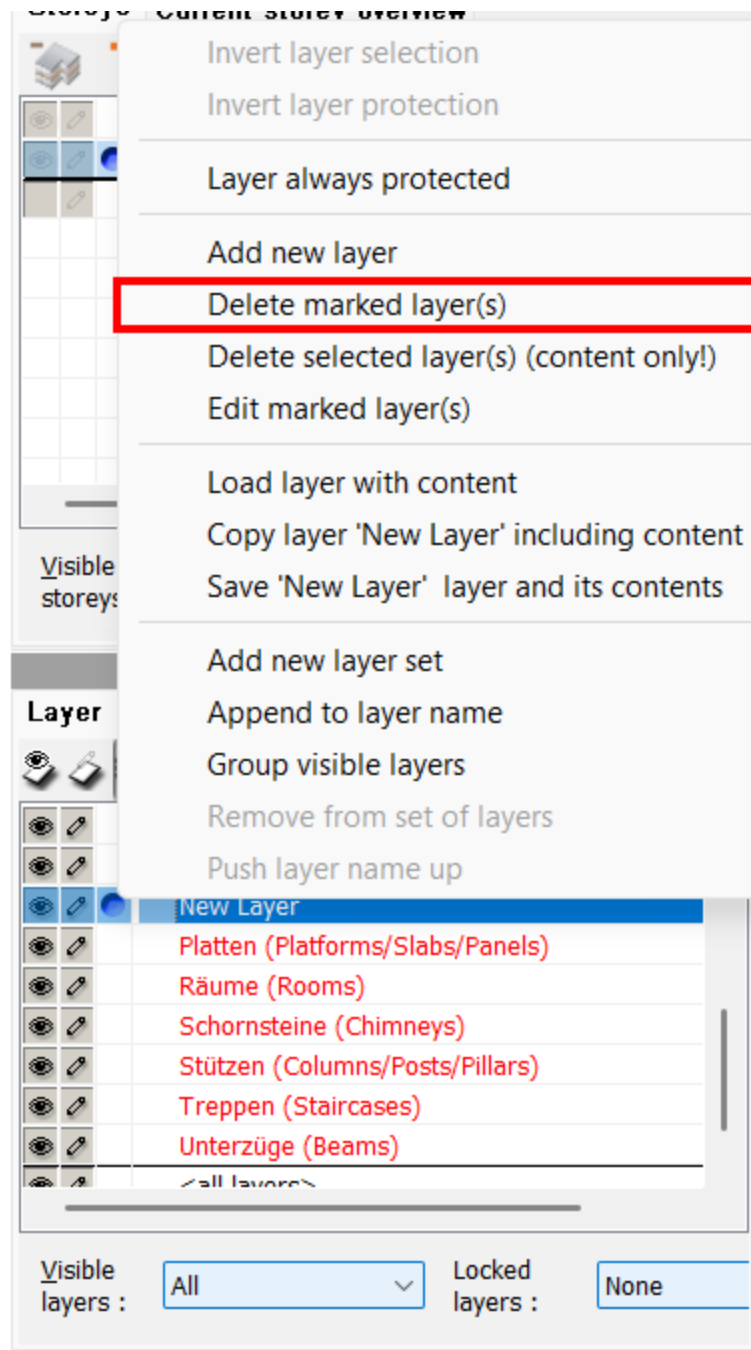

A confirmation prompt now appears with the name of the layer to be deleted. Confirm by clicking on **OK**:

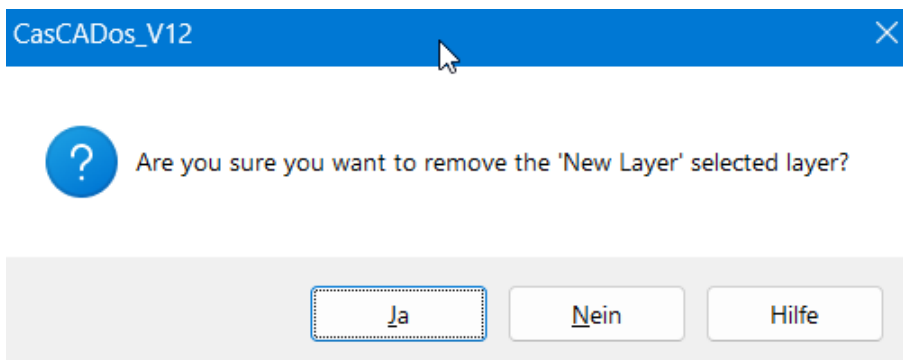

#### 4.3.1.4 Rename layer

see [Edit layer](#)

#### 4.3.1.5 Edit layer

The Edit layer dialogue can be opened from the layer and storey management. Select the desired layer

in the list and click on the **Edit marked layer** button  or select the function in the context menu (right-click).

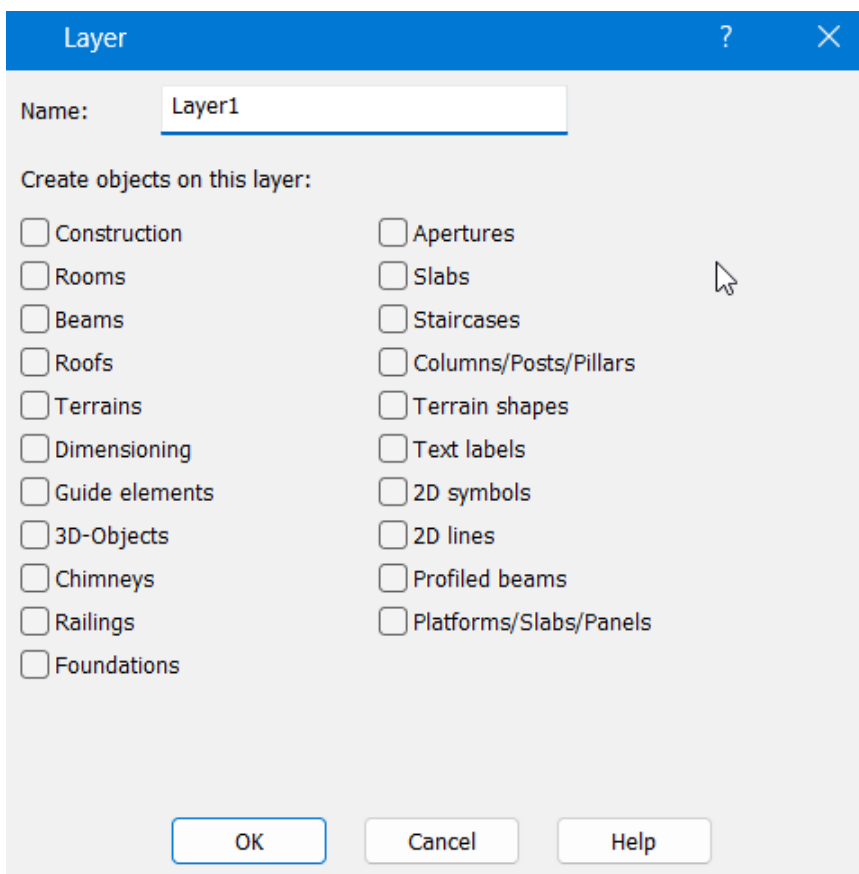

In this dialogue, set the name of the layer and the selection of element types to be stored on the layer.

#### 4.3.1.6 Which layers should be created?

This question is not easy to answer, as it depends very much on the type and size of the project which layer structure makes sense.

Never the less, here are a few tips that may help you to organize your projects.

Furnishings, whether 3D objects or 2D symbols, should each be placed on a separate layer.

Electrical plans, ducts and sanitary objects should also be on a separate layer. Use the option of starting the layer name with a prefix to clearly display related layers, e.g. of a trade, in a row.

Example for the electrical area: EL\_Symbols, EL\_Cables, EL\_Labeling.

Many layers are automatically created and managed as required anyway.

This has the advantage that you only have to pay attention to the active layer when entering the project if elements are drawn that are not automatically placed on the intended layer.

For standard projects, it makes sense to create each layer required for complete project processing once and to save this information in **standard.cad**.

The layer [set](#)<sup>[116]</sup> can be used for the organization.

#### 4.3.1.7 Layer assignment for drawing elements

In Plan7Architect, drawing elements are stored on the active layer ([What is the active layer?](#))<sup>[104]</sup> or the drawing element type is permanently assigned to a layer. The assignment is made in the "Edit layer" dialog.

(double-click on the layer)

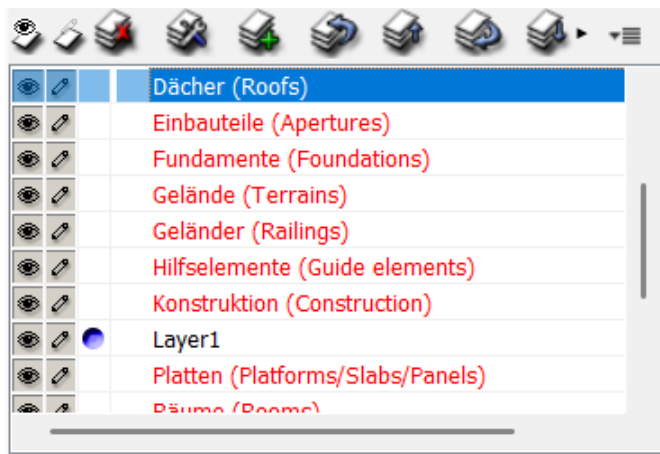
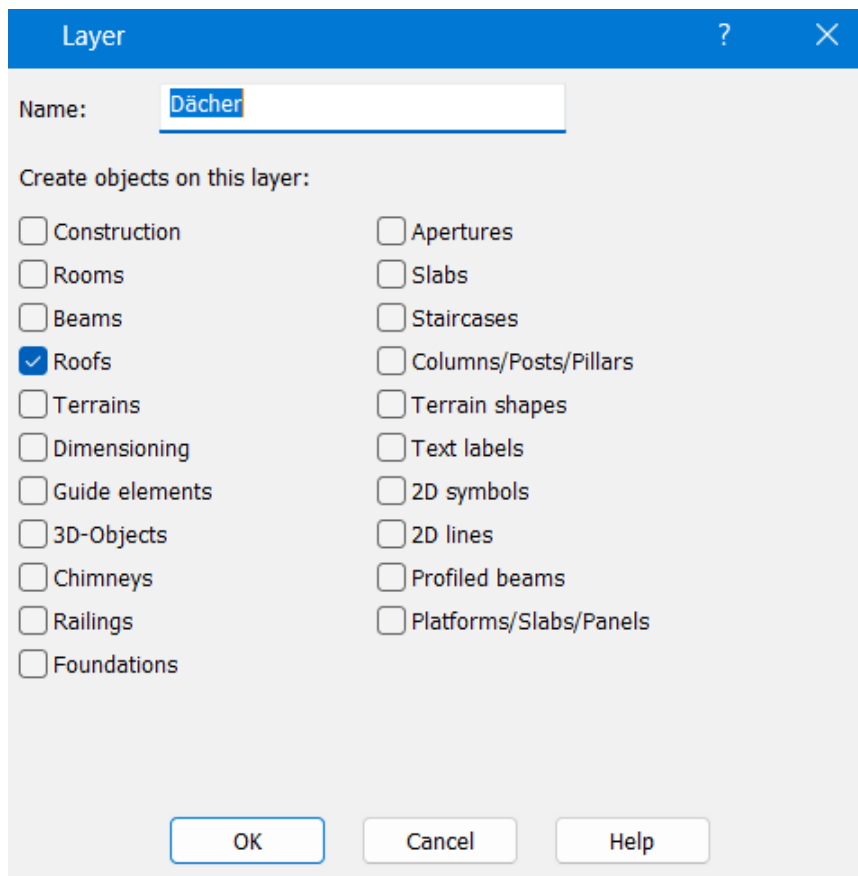

If an element type is assigned to a layer, the layer name appears in red in the layer list. All elements can be subsequently moved to another layer (Layer properties dialog)

#### 4.3.1.8 Visible layers

An important reason why Plan7Architect divides drawings into layers is to give the user the freedom to choose which drawing elements should be displayed or printed. To make this selection, choose from the three options described below in the **Visible layers** selection list in layer management:

- **All** - all layers of the planning are visible
- **Active** - only the active layer is shown at any one time

- **Selected** - select the visible layers in the first column of the list (symbol with the eye); the active layer is always visible.

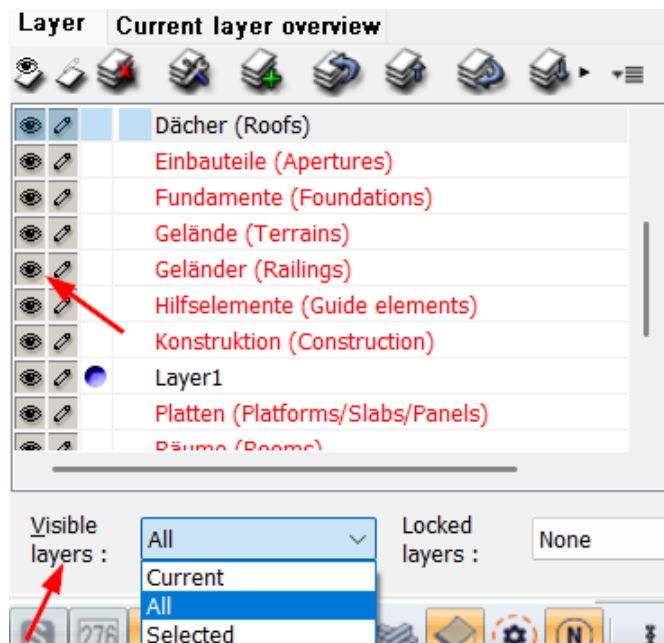

#### 4.3.1.9 Layer always protected

If only one layer is selected in layer management, the "Layer always protected" function can be called up in the context menu.

A lock now appears in the list as the symbol for editing instead of the pencil.

This layer is now excluded from the management of editable layers and is always locked.

#### 4.3.1.10 Protected layers

If a layer is protected, elements on this layer cannot be selected and edited. This does not change the visibility of the layer. You can select which layers are protected in the **Protected layers** selection list in layer management. There are three options to choose from:

- **None** - no layer in the planning is protected
- **All except active** - all layers are protected, only the active layer is enabled for editing.
- **Selected** - select which layers can be edited in the second column of the list. The layers marked in this way (symbol with the pencil) are not protected.

Important: Elements with a fixed layer assignment are still created on this layer, even though the corresponding layer is protected. However, it is no longer possible to edit the element afterwards without removing the protection.

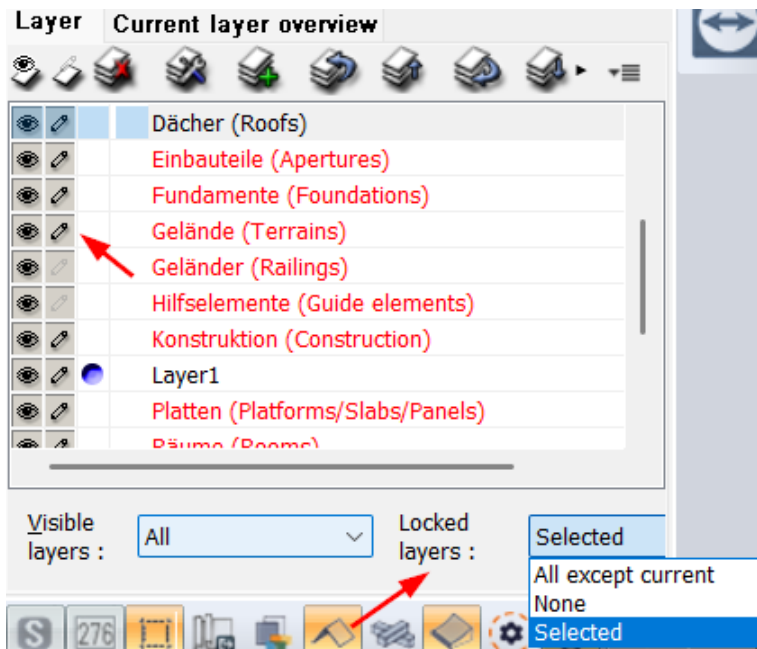

### Layer always protected

In the context menu of a layer or layer set, this layer/layer set can be "always protected". Regardless of the selection of layers to be edited, this layer remains protected, marked with a lock. Use this function to permanently protect an imported site plan from editing, for example.

#### 4.3.1.11 Layers in the model, in views and plan layouts

Plan7Architect manages your project in a consistently designed layer structure to enable clear editing even for complicated projects.

In the **Construction, 3D and Terrain** modes, you edit your planning, the actual model of the building, hence the term **model area** as an umbrella term for all three modes.

In **2D views** mode, views, sections, detailed drawings or any other 2D drawings are constructed.

In the **plans** mode, the results from the model and 2D areas are combined into a plan and supplemented with 2D drawing elements (frame, plan, header, texts) to create a finished plan.

Separate layer structures are available in the planning (= the actual model in the construction, 3D and terrain modes), in the 2D views (= views, sections or other 2D drawings) and the plan layout.

### Layer structure in the model area

Each storey in the planning always has the same layer list. If, for example, a new "Labeling" layer is created on the first floor, it is also available on all other floors. If you delete this layer, it will be deleted in all storeys.

Each 2D view has its own layer list that is independent of all other drawings.

If, for example, a new "Labeling" layer is created in the East view, all other 2D views (the model and plan area anyway) are not changed. This also applies to the deletion of a layer.

Layers are automatically created in the 2D area when you display a view or a section.

Layers are created for contours, cut edges and cut surfaces.

Further information on this can be found in the [2D views](#)<sup>[479]</sup> chapter.

A representation from the construction area, for example the first floor, can be converted into a 2D view. All drawing elements are broken down into 2D drawing elements (e.g. a staircase into the lines of its 2D representation).

In the new 2D view, the 2D elements are stored in the layer on which the components lie in the construction area.

Components are located in the construction area. This results in the same layer structure as in the design area.

#### 4.3.1.12 Layer set

From version 3, it is possible to create a **layer** set in layer management.

Layer set means that you have a further subdivision option in layer management and different layers can be combined into a layer set.

This layer set can be switched on and off and can, for example, contain all drainage layers, or all layers that manage 3D objects or other summaries.

Creating a layer set: Right-click on a layer and select the corresponding option:

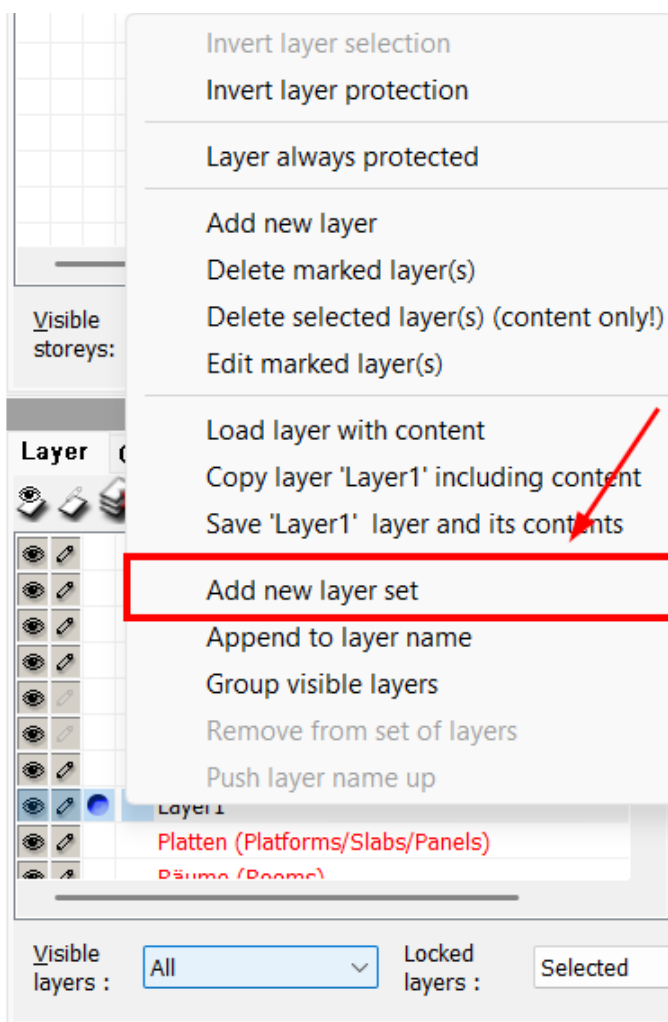

Assign a name for the layer set:

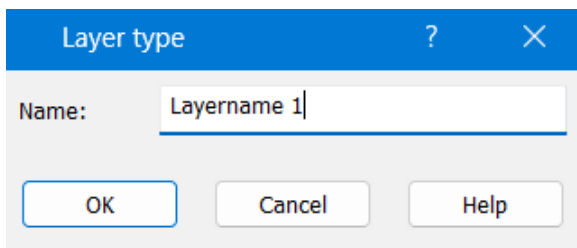

right-click on the new layer set and insert new layers:

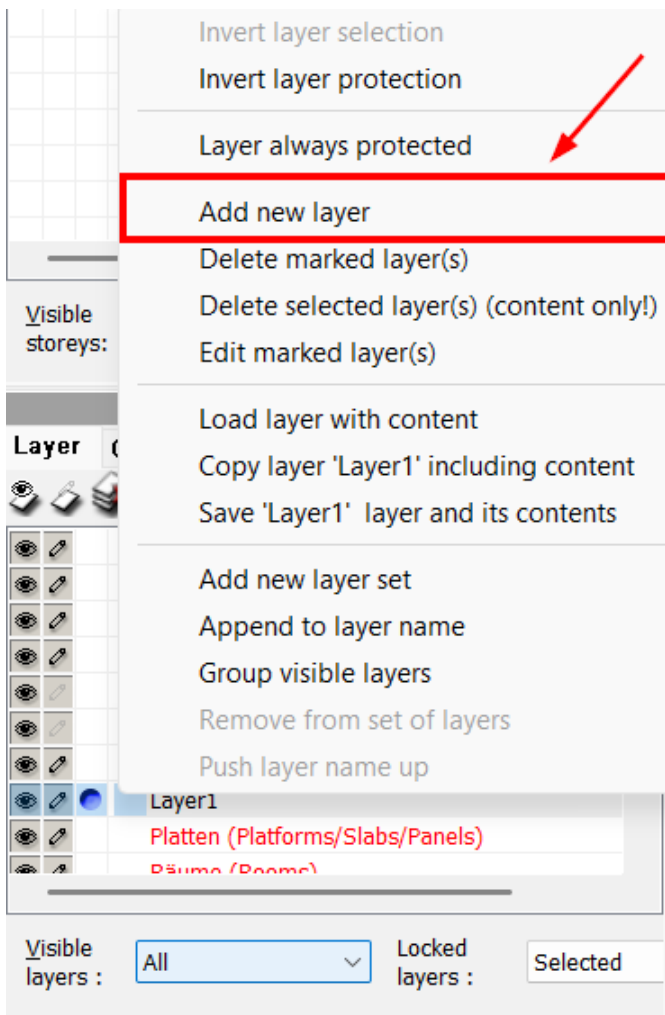

or simply drag and drop existing layers under the layer set.

Several layers can also be selected and subsequently merged into a layer set (right mouse button):

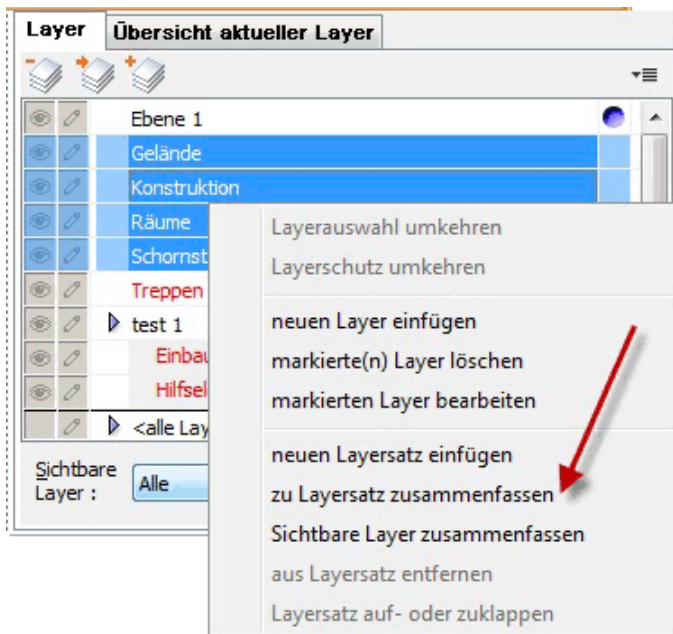

Layers from DWG/DXF import are always saved as a layer set.

#### 4.3.1.13 Loading and saving layers

You can find this function by right-clicking on a layer.

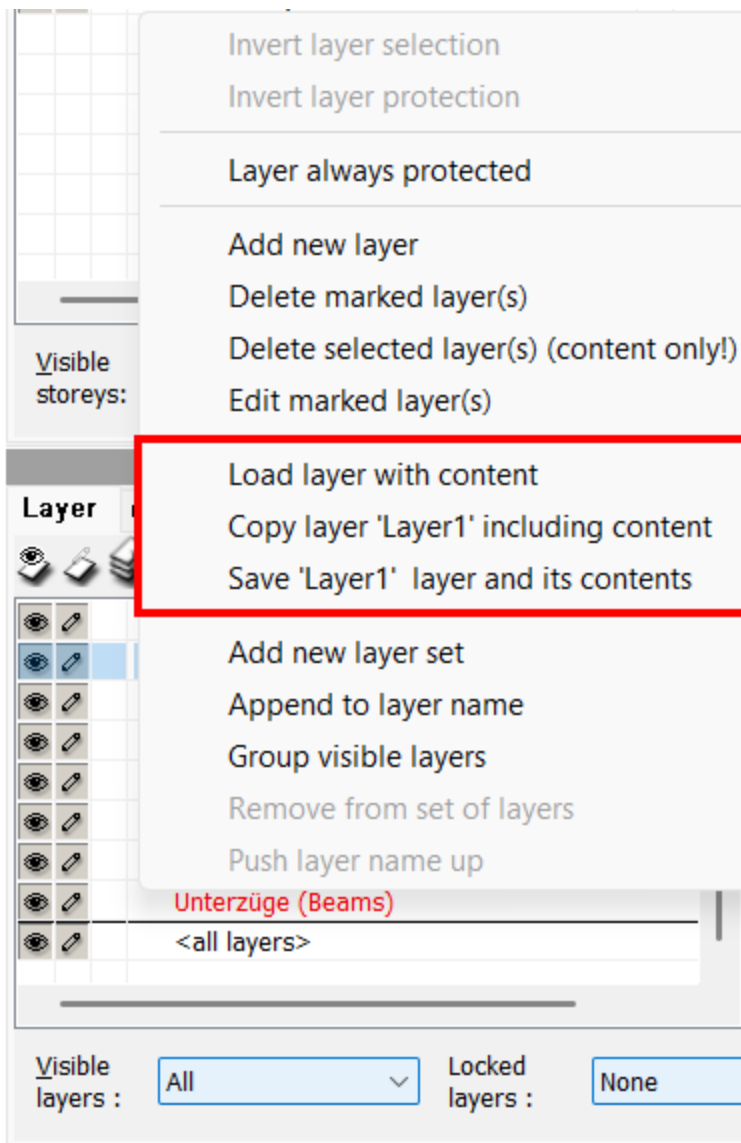

***Load layer with content ...***

loads a \*.layer file into the open project.

***Copy layer including content ...***

copies the layer including it's contents

***Save layer '\*' and it's content ...***

creates a \*.layer file in a directory of your choice.

You can use these two commands to load many elements simultaneously from one file into another file, the positions remain the same.

### 4.3.2 Storesys

Plan7Architect assigns all inputs for the model to a storey. The model is edited in the Construction, 3D and Terrain modes. In the 2D views and plans modes, you can select which storeys of the model are shown.

There is always at least one storey in a new project. However, by using a suitable preliminary drawing, the desired list of storeys can already be available at the start of planning.

Open storey management by clicking on the  button in the explorer bar.

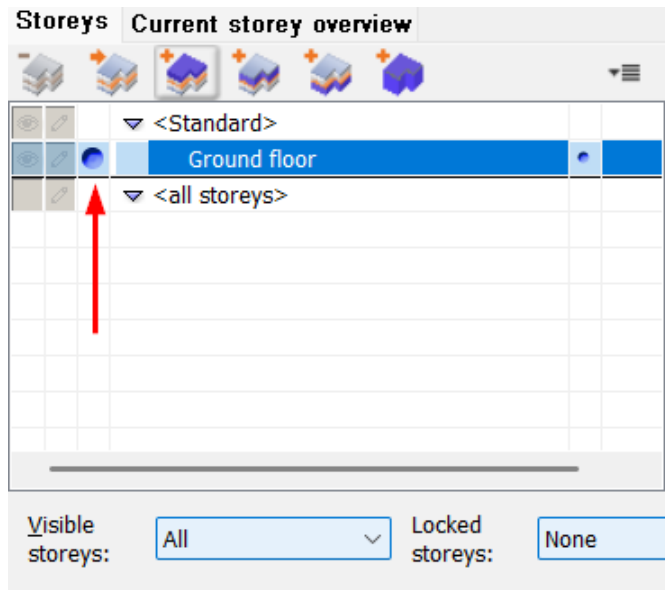

The list of all storeys in this project is displayed. The storeys are sorted by height and the level of the finished floor is displayed for information purposes.

#### More information about:

- [What is the active storey?](#) <sup>120</sup>
- [Create a new storey](#) <sup>121</sup>
- [Delete a storey](#) <sup>124</sup>
- [Edit a storey](#) <sup>125</sup>
- [Dependencies between storeys](#) <sup>125</sup>
- [Visible storeys](#) <sup>126</sup>
- [Protected storeys](#) <sup>127</sup>
- [Wooden construction](#) <sup>128</sup>
- Masses

#### 4.3.2.1 What is the active projectile?

Only one storey is active at a time, in this case the first floor (marked by the blue circle).

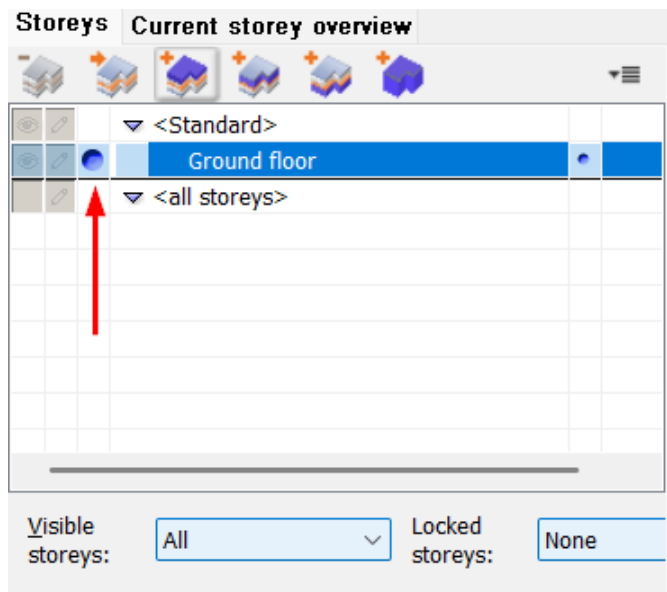

#### All entries of new elements now refer to this storey.

The active storey can be changed by clicking on the line of the desired storey in the active column in the storey management, the marking moves to the new active storey.

The large blue button behind the storey name shows the current storey. This means that it can neither be deleted nor hidden.

The smaller blue button in the second column behind the storey name determines the visibility of the stairs component if there are several buildings (e.g. semi-detached house or terraced house) with the view option: **Stairs visible through holes** on the upper floor.

Optionally, the active storey can be selected in the **Storey** selection list, the **dialog line** or in the **Storeys** menu.

Select the active storey in the **selection** list **Storey (bottom left)**:

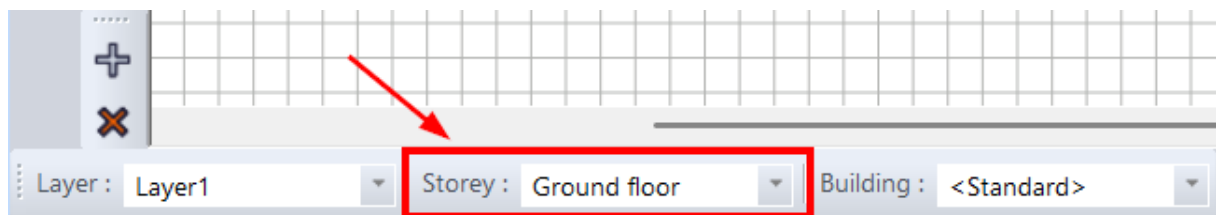

#### 4.3.2.2 Create a new storey

Three buttons  are available in storey management for creating a new storey. You can:

- a storey above the highest storey (first button)
- a storey above the current storey (second button)

- a storey below the lowest storey can be created.

The following dialog appears after selection:

Select the storey type. If there are several buildings in this project, you can select the building for this storey in the **Building** selection list.

### The height parameters

**Storey height:** The height between the top edge of the finished floor of this storey and the storey above is the storey height. If there is no storey above, this height extends to the upper edge of the bare floor. If you change the storey height, the levels of the storeys above are adjusted. The change within the storey is recorded in the *clear height*.

**Structural height:** All individual heights (from bottom to top: floor, clear height, suspension and ceiling) are added together to give the structural height. If you change the structural height, the levels of the storeys above are adjusted. The change within the storey is included in the *clear height*.

**Unfinished ceiling:** The ceiling of a storey is normally above the rooms. The ceiling thickness is assumed to be this value for ceiling slabs and automatically generated storey ceilings. Deviations are possible for ceiling slabs. If you change the bare ceiling value, the change will be included in the storey *heightvalue* .

**Suspension:** A change to the height of the suspension is included in the clear *height* value.

**Clear height:** The distance between the upper edge of the finished floor and the lower edge of the suspension is referred to as the clear *height*. If you change the clear *height* of the storey, the level in the storey above is corrected.

**Floor:** The floor structure is assumed for all rooms on this storey, except for all rooms for which a different height has been explicitly entered. Changes to the floor structure are only adjusted in the clear height of the storey and in the level. All other values are not affected.

**Level:** Level refers to the absolute height of the storey in relation to the top edge of the floor. These absolute height specifications refer to the absolute 0.00 of the project. If this value is changed, all other storeys are also adjusted.

**Fix level:** In a building, only one storey at a time can be given this option. This storey level cannot then be changed by all height adjustments to this and all other storeys.

Alternative option: Create a new storey via the context menu (right-click)

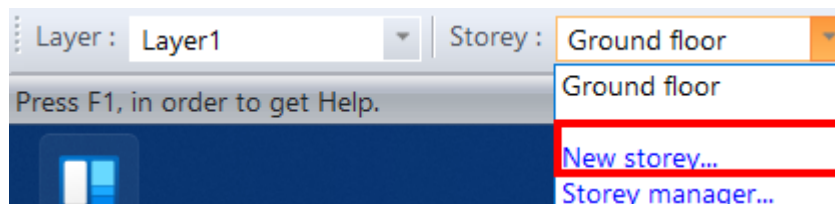

**Options:**

- Add new top storey
- Insert new storey above the current one
- Add new bottom storey

Alternative option: Create a new storey via the selection list *Storey (bottom left)*

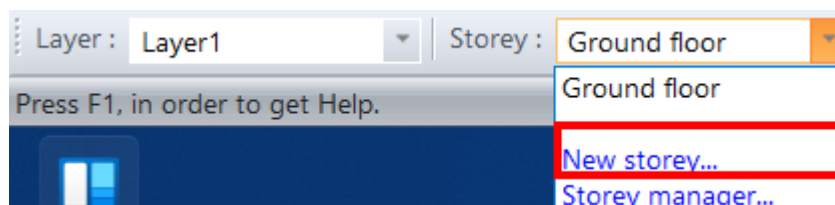

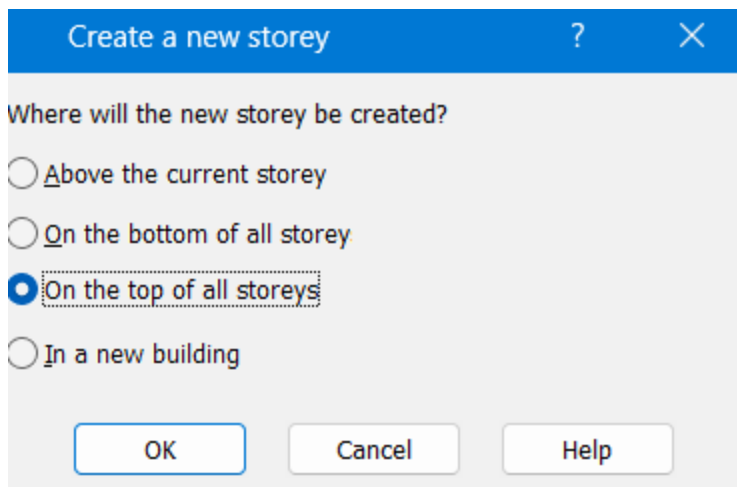
**Options:**

Above the current storey  
 On the bottom of all storeys  
 On the top of all all storeys  
 In a new building

**4.3.2.3 Delete a projectile**

Use the mouse to select the line of the storey and click on the button  **Delete storey**. The storey, all layers and all elements contained on it are deleted.

Alternative option: via the context menu (right-click)

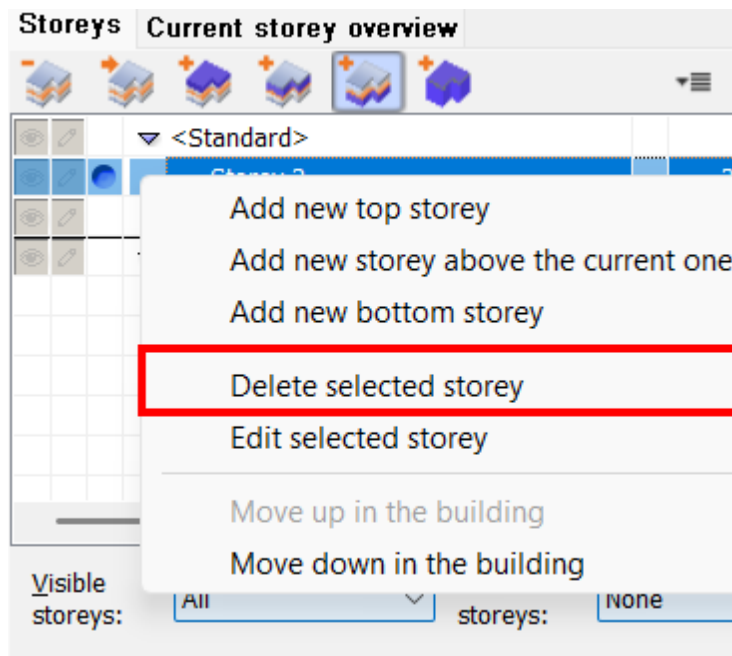

A confirmation prompt appears, confirm this with **OK**.

#### 4.3.2.4 Editing a floor

Select the line of the storey with the mouse and click on the button  **Edit storey**. The dialog as for creating a new storey appears.

Alternative option: via the context menu (right-click)

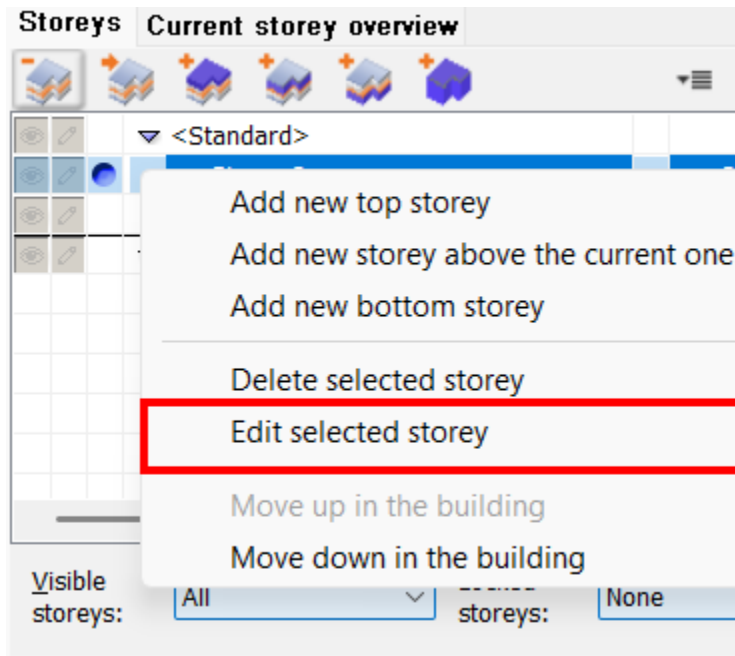

#### 4.3.2.5 Dependencies between storeys

If you are working with several storeys in Plan7Architect, the floor levels of the storeys are determined in such a way that all storeys merge "seamlessly" into one another.

For example, if you have defined a first floor with a floor height of 2.80 m and the upper edge of the floor on the first floor has an absolute level of 0.00 m, the upper edge of the floor on the upper floor above will be 2.80 m. If you change the level on the first floor, all other floors will also be moved.

The **Fix level** option can be used to fix the level of a storey within the building. All changes below this level only change the height of the storeys below. All floors above remain unchanged.

Storey type : Storey 3

Description:

Building : <Standard>

Master data automatic slabs: Standard-STB  No automatic slabs

Storey height: 275.0 cm

Construction: 280.0 cm

Level: 280.0 cm

Structural slab: 25.0 cm

Ceiling: 0.0 cm

Clearance: 250.0 cm

Lock storey level:

Floor: 5.0 cm

Buttons: Load, Definition name: , Save, Delete, OK, Cancel, Help

#### 4.3.2.6 Visible storeys

To select which storeys are visible, choose from the three options described below in the **Visible storeys** selection list :

- **All** - all storeys in the plan are visible
- **Active** - only the active storey is shown at any one time
- **Selected** - select the visible storeys in the first column of the list (symbol with the eye), the active storey is always visible
- **Active + above** - the active storey and the storey above it are displayed
- **Active + below** - the active storey and the storey below it are displayed

All

Current

Active+Above

Active+Below

All

Selected

Optionally, this selection can be made in the **storeys** menu or with the shortcut keys **[F6]**, **[F7]** and **[F8]**.

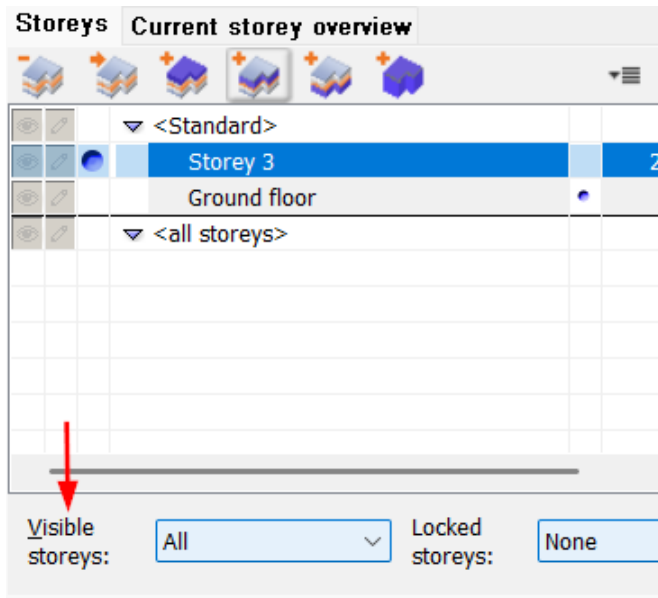

In storey management, you can see all buildings with the associated buildings. Individual storeys can be switched on or off or entire buildings.

The smaller blue button in the second column behind the floor name determines the visibility of the staircase component if there are several buildings (e.g. semi-detached house or terraced house) in the view option:

**Stairs visible through holes** on the upper floor.

#### 4.3.2.7 Protected floors

If a storey is protected, elements located on this storey cannot be selected and edited. This does not affect the visibility of the storey. You can select which storeys are protected in the **Protected storeys** selection list in storey management. There are three options to choose from:

- **None** - no storey in the planning is protected
- **All except active** - all storeys are protected, only the active storey is enabled for editing
- **Selected** - select which storeys can be edited in the second column of the list

The storeys marked in this way (symbol with the pencil) are not protected.

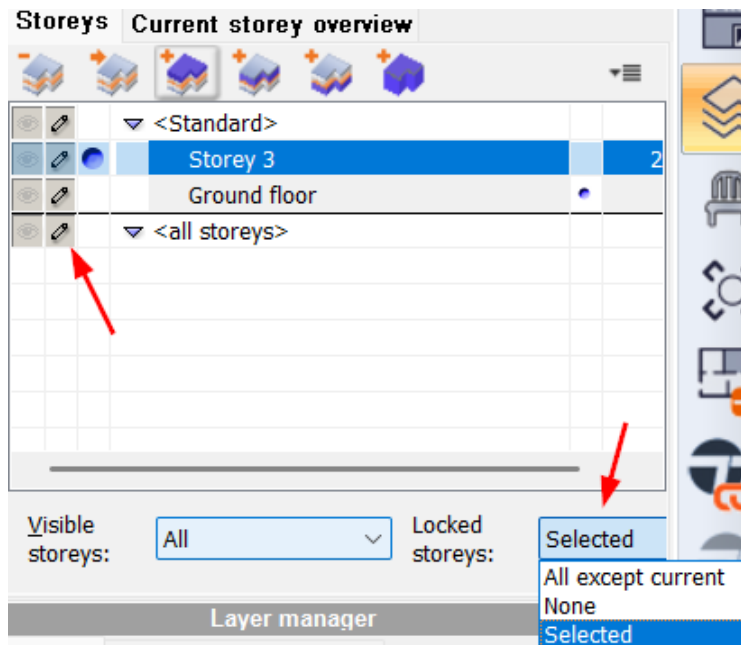



#### 4.3.2.7.1 Wooden construction

The automatic floor slab created for each storey can optionally represent a timber construction. To do this, open the **General tab** checkbox at **With timber construction** in the dialog **Edit selected storey**.

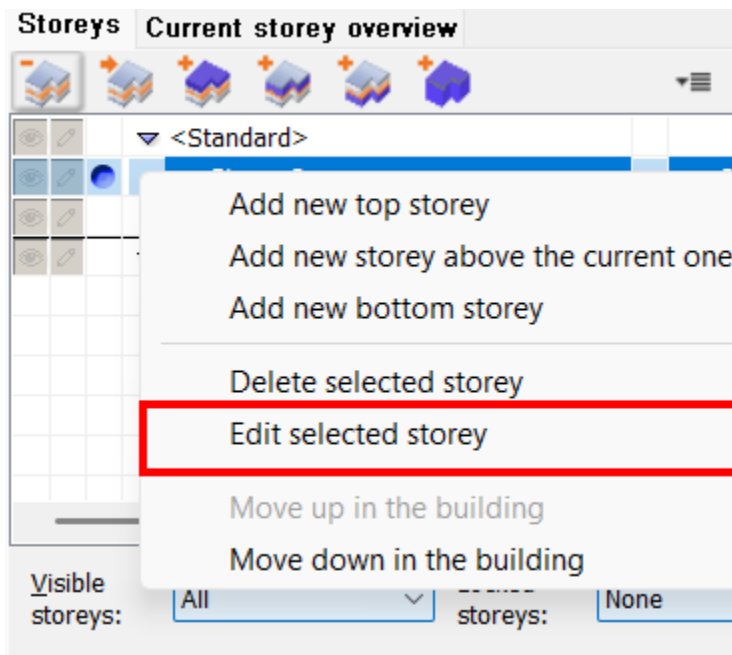

The dialog can be edited via the context menu (right-click) **Edit** selected storey



or from the storey management via the button  **Edit selected storey** .

In the window that now appears, first click on the tab **General** and then click on the checkbox **With timber construction**; the input options are now active:

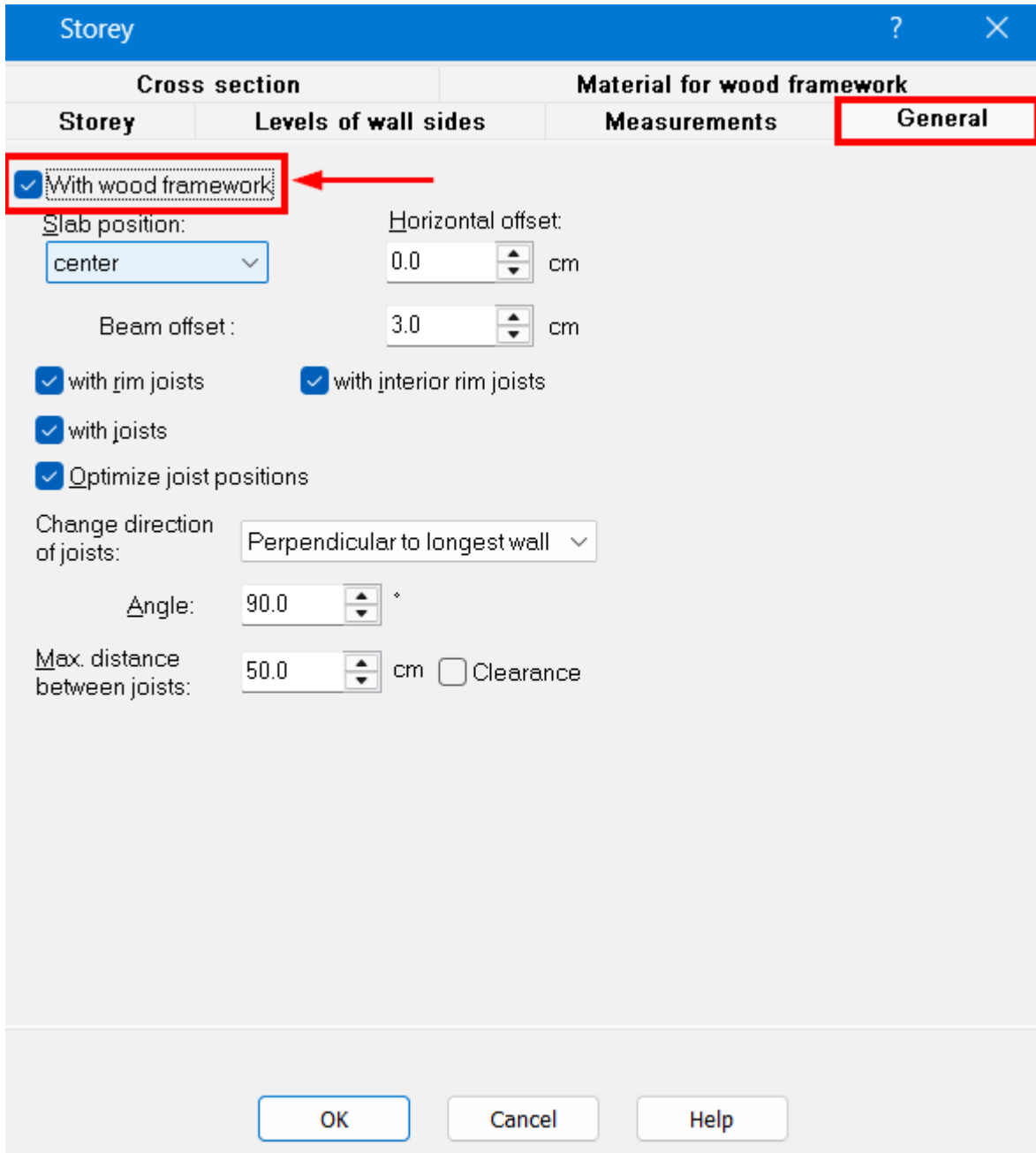

The screenshot shows the 'Storey' dialog box with the 'General' tab selected. The 'With wood framework' checkbox is checked and highlighted with a red box and arrow. The 'Slab position' is set to 'center', 'Horizontal offset' is 0.0 cm, and 'Beam offset' is 3.0 cm. The 'with rim joists', 'with interior rim joists', 'with joists', and 'Optimize joist positions' checkboxes are all checked. The 'Change direction of joists' is set to 'Perpendicular to longest wall', 'Angle' is 90.0 degrees, and 'Max. distance between joists' is 50.0 cm. The 'Clearance' checkbox is unchecked. The 'OK', 'Cancel', and 'Help' buttons are visible at the bottom.

#### 4.3.2.7.1.1 General

The timber construction is switched on with the **With timber construction**



option button.

Please note that either **Display** or **Exclusive** must be selected in the context menu to display all timber constructions!

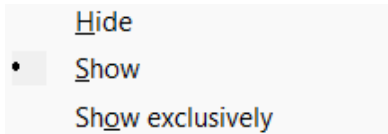

The selection **Position in the ceiling** determines the height of the construction in the ceiling. **Centered** means that the axes of the wooden beams are centered in the ceiling, **Inside** means that the axis of the beams is exactly at the height of the lower edge of the ceiling, **outside** is the same as the top.

The **internal offset** is the distance between the wooden beams and the outer contour of the floor slab or to the contour of the ceiling opening.

 A screenshot of a software settings dialog for timber construction. The dialog has a light gray background and contains several sections:
 

- Mit Holzkonstruktion
- Position in der Decke: mittig (dropdown menu)
- Versatz: 0,0 (spin box) cm
- Innenversatz der Balken: 3,0 (spin box) cm (highlighted with a red box)
- mit Randbalken     mit inneren Randbalken
- mit Balken
- Position der Balken optimieren
- Verlegerichtung der Balken: senkrecht zur längsten Wand (dropdown menu)
- Winkel: 90,0 (spin box) °
- Max. Abstand zwischen Balken: 50,0 (spin box) cm     lichtetes Maß

Which beams are constructed is set using the **Edge beams**, **Inner edge beams** and **Beams** radio buttons.

Inner edge beams are created along ceiling openings.

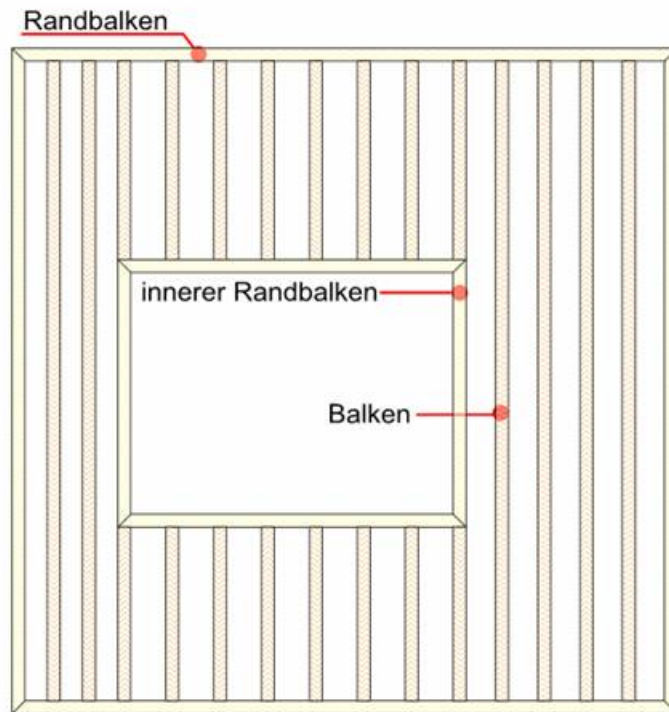

The laying direction of the beams can be defined with:

- **as longest wall** - The beams are created parallel to the longest contour edge.
- **perpendicular to the longest wall** - The beams are created perpendicular to the longest contour edge.
- **Angle** - Specify the angle as a numerical value.

The distance between the beams can be entered with the value **max. distance** between the beams. Optionally, the clear dimension between the beams can also be entered. However, the timber construction is automatically determined so that the corner points of ceiling openings or the inner edge beams created there are flush with the beams.

#### 4.3.2.7.1.2 Cross sections

You define the cross-sections of the wooden beams in the **Cross-sections** tab.

If the **plus superstructure thickness** option is activated, the thickness of the floor slab is added to the thickness of the beams. The value **- 5.0 cm** means that the beam is drawn 5.0 cm lower than the ceiling.

Querschnittsmaße für	Breite:	Dicke:	zuzüglich Aufbaustärke
Randbalken	12,0 cm	-5,0 cm	<input checked="" type="checkbox"/>
Balken	12,0 cm	-5,0 cm	<input checked="" type="checkbox"/>
Innere Randb.	12,0 cm	-5,0 cm	<input checked="" type="checkbox"/>

## 4.3.2.7.1.3 Material for timber construction

Here you can assign different textures to your timber construction. The display method differs for the 2D view and for the 3D view.

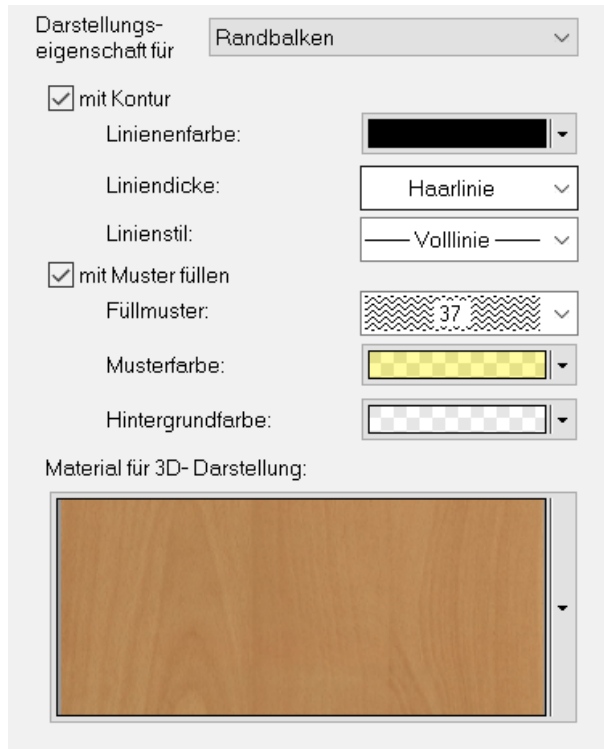

The following options are available in the 2D area:

***Display property*** for:

- **Edge beams**
- **Beams**
- **Inner edge bars**

Select the desired element from the drop-down menu:

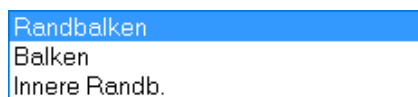

Select whether you want to assign a **contour** and/or a **pattern** to the timber construction in the 2D view:

- **With contour** ( options:line color/line thickness/line style)
- **With pattern** ( options:fill pattern/pattern color/background color)

Numerous different materials/textures can be defined for the 3D display. To do this, click on the down arrow icon next to the material preview window under **Material for 3D display**.

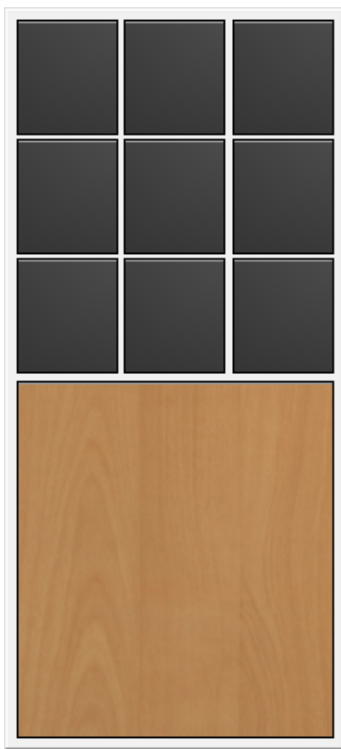

Now click **twice** with the **left mouse button** on the texture/material shown, another editing window with the **material settings** will now appear:

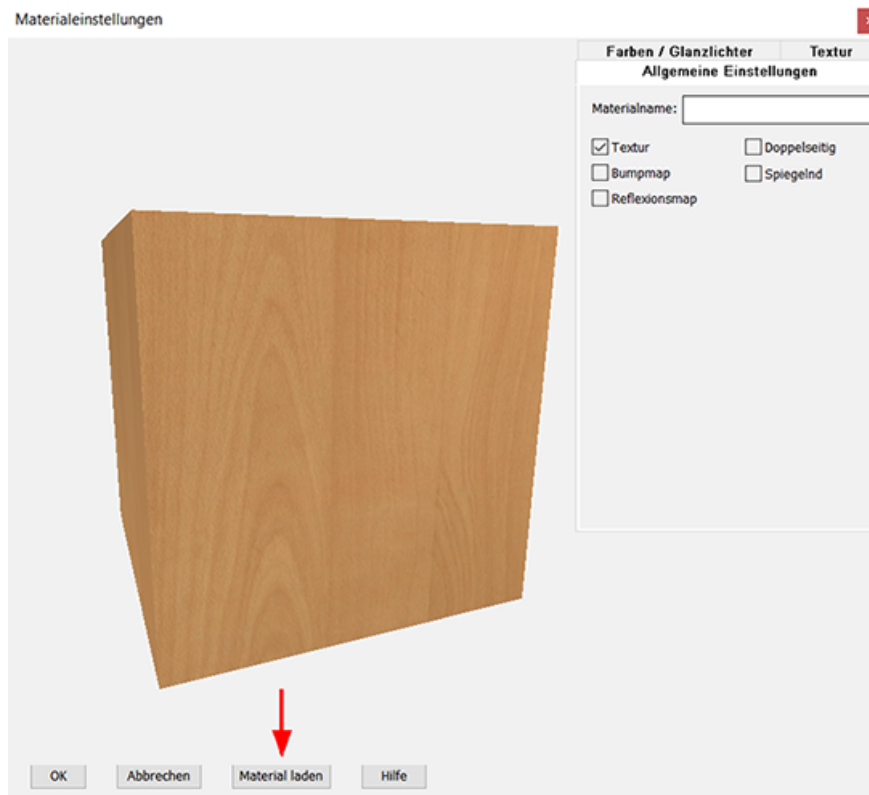

In the top right-hand corner there are three tabs in which additional settings can be made for **colors/glow lights** or the **textures**.

If you want to load a new texture from the 3D Explorer templates, click on the **Load material** button:

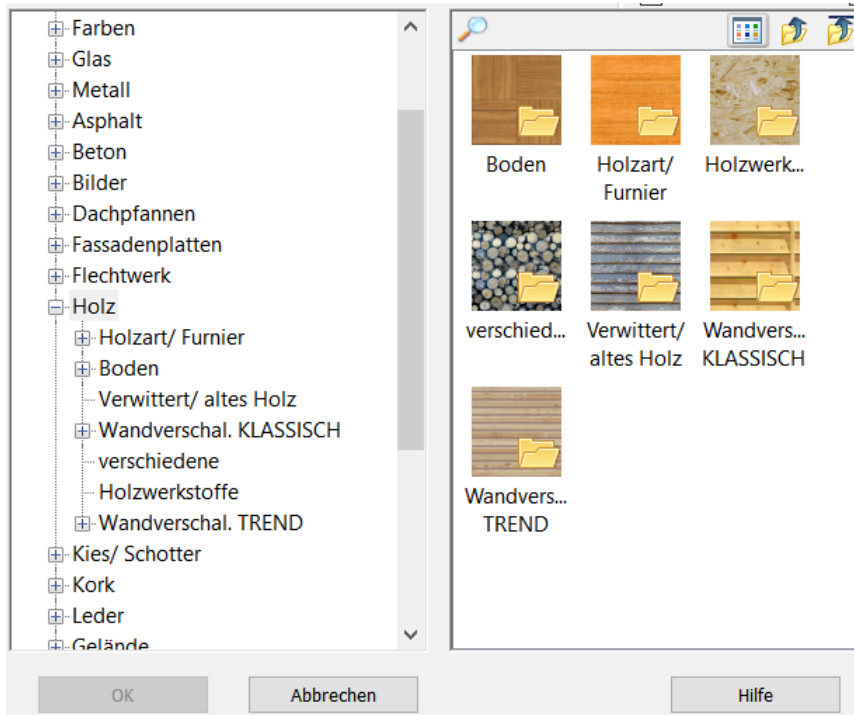

Confirm the selection with **OK**. The selected material is now displayed in the preview. You can also edit it yourself using the options at the top right. Click **OK** again to accept the material for the 3D display.

## 4.4 General property dialogs

These property dialogs are offered repeatedly for many elements in <%SOFTWARE% >, so they are summarized here in one place to avoid having to explain how they work repeatedly.

### 4.4.1 Change colors



Click on the Color control element. A color chart with 15 colors opens. The color chart allows you to save the settings for frequently used colors.

#### Selection from the color chart

Select the appropriate panel by clicking with the mouse, the selection window closes. Each color can be picked up from the screen using the pipette.

### Editing the current color

Click on the wider color field at the bottom of the dialog. The Color selection dialog opens.

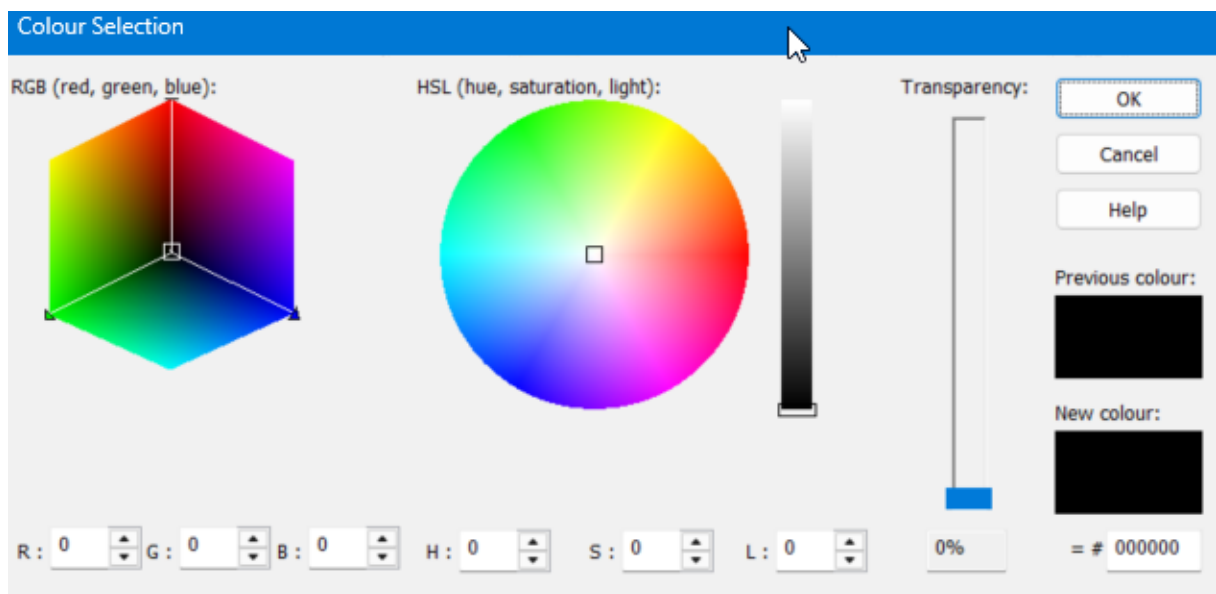

### Editing the color panels

Right-click on one of the color fields. A window for editing the current color opens.

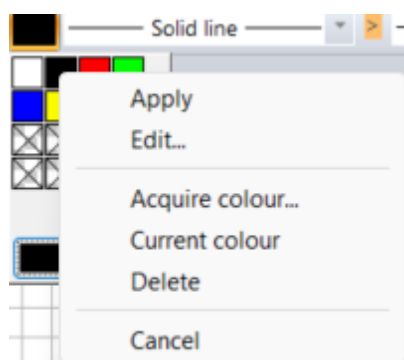

- **Apply:** The color is applied and the selection window closes (like clicking on the color).
- **Edit:** Opens the Color selection dialog for editing (see above).
- **Pick up color:** uses the eyedropper to set the color for the current color box.
- **Current color:** The current color is added to the current box in the color chart.
- **Delete:** The color of the current box will be deleted.

#### 4.4.1.1 The color selection dialog

The colors of a color space are quantified by a color space system. A colour space system is a coordinate system in which the individual colors are characterized by basic coordinates on different axes. Due to the structure of the human eye, in most cases there are three axes for color spaces intended for human observers.

On the one hand, there are technical-physical models in which colors are mixed from other colors (e.g. RGB, CMYK), on the other hand, there are perception-oriented models that describe colors by the characteristics of brightness, saturation and hue (e.g. HSV, HSL).

Plan7Architect provides the RGB and HSL color models.

**RGB color model:** Red Green Blue is an additive color model in which the primary colors add up to white (light mixing). A color is described by three values: the red, green and blue components. The value range of each individual color extends from 0 to 255, where 0 stands for the lowest and 255 for the highest intensity. Consequently, 256 gradations can be specified for each color channel. This means that  $256 \cdot 256 \cdot 256 = 16,777,216$  different colors can be displayed. This representation is also known as true color.

**HSL color model:** The color is represented by vectors consisting of: Hue (color tone), Luminance (brightness) and Saturation (saturation).

Hue and saturation are selected from a value range of 0 - 255 in the color wheel.

The brightness is influenced using the slider.

**Transparency:** The transparency of the color can be varied with a value range from 0 to 100%. This allows an outline or fill to be displayed as translucent.

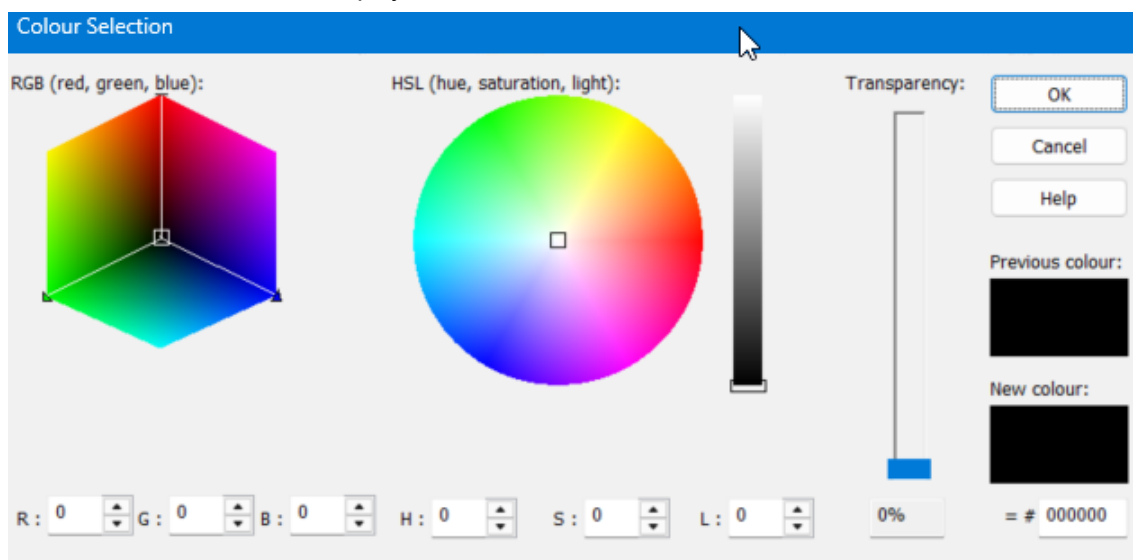

#### 4.4.2 2D representation

The outline, fill and hatching of an element are defined in this dialog.

Material: Select a

2D material

[Contour](#) <sup>138</sup>

[Fill](#) <sup>140</sup>

[Hatching](#) <sup>141</sup>

Display

**Floor plan** **Cross section**

Material: # Freely definable #

Display outline

Colour:      Thickness: 0,25 mm

Pattern: ——— Solid line ———

Fill type : Constant colour

Colour 1 :      Colour 2 :     

Fill pattern : ————— 1 —————

Picture :                     

Picture tiling : Tile.

Rotation : 0,0 °

Picture Size :

w : 100,0 cm h : 100,0 cm

mirrored  mirrored

Move :

x : 0,0 cm y : 0,0 cm

Move with Element

Hatch: Not hatched

#### 4.4.2.1 Contour

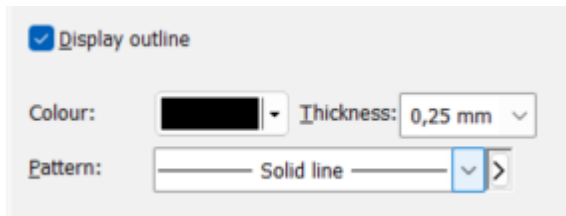

^

The 2D display of the contour(s) for 2D elements (such as line, polygon or circle) or components (walls or ceilings) can be set in the **Contour** properties dialog.

**Display contour:** The contour of the element is displayed. This option is not available for lines.

**Close contour:** If the option is selected, the drawn element is automatically closed. This function is only available for **polygon** and **arc** elements.

**Fill alternately in case of self-intersection:** If the contour of an element overlaps itself, alternating fill is switched on with this function (left with alternating fill, right without).

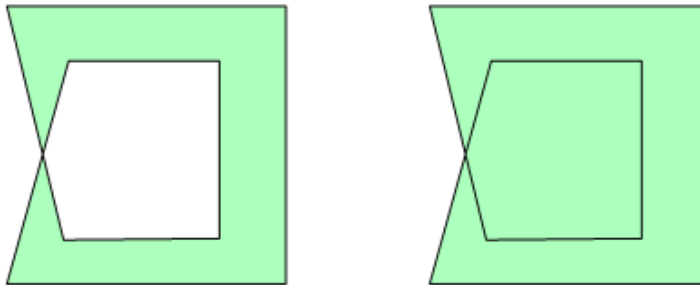

**Color:** See chapter [Change color](#)<sup>134</sup>.

**Thickness:** The line thickness of the contour in mm on the paper. The line thicknesses are therefore displayed and printed in this thickness regardless of the scale of the project (or printout).

**Pattern:** Select the line pattern. The parameters of the line pattern can be changed by clicking on the right arrow symbol > (Edit). The **Contour** dialog opens with the line type parameters.

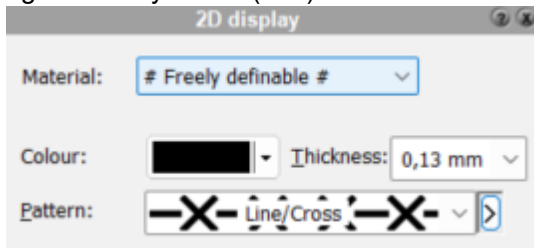

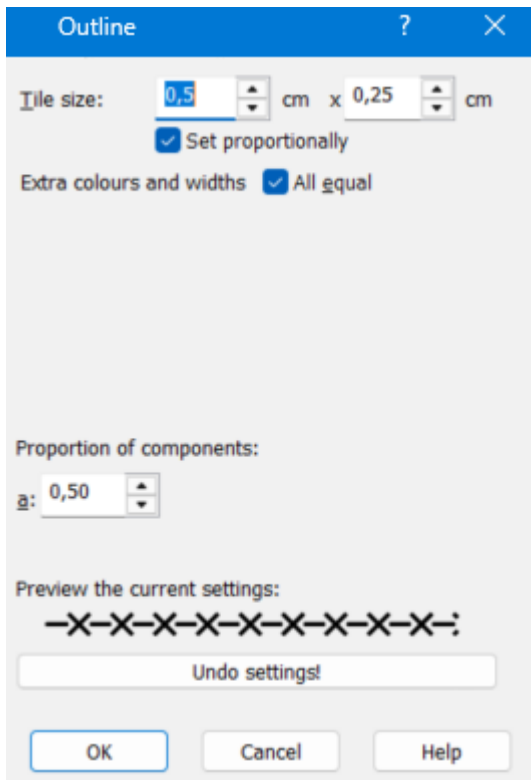

In this example, the line type dash - cross is shown.

**Tile size:** determines the width and height of the line pattern in cm in the printout. Setting the values to 0.5 and 0.25 makes the line pattern appear 0.5 cm wide and 0.25 cm high on the printout, regardless of the project scale set. The width of the tile is the distance to the first repetition of the pattern. The line type line - cross consists of a line and the cross (see illustration).



If you change one of the values, the other is also changed ( **Keep proportions** option ) so as not to affect the appearance of the line type.

**Colors and thicknesses:** Normally, all elements of a line type have the same color and line thickness (equal to the element's settings in the **Contour** dialog ). For special requirements, however, each element can be set independently of the main line. For example, the cross can be displayed in a different color for the line type Dash - Cross as shown.



**Proportions:** These parameters can be used to change the geometry of the line type. For example, the distance between two line segments can be varied for a dashed line. In our example of the dash-cross line, the ratio of line to cross is changed. Depending on the line type, the parameters are labeled with letters a to ..... It is not possible to name these parameters exactly, as the effects of the parameters are

different for each line type. (A parameter would read something like: Ratio length-line to width-cross!!!)  
Here it helps - just try it out.

#### 4.4.2.2 Fillings



Fill type :

Colour 1 :  Colour 2 :

Fill pattern :

Picture :

Picture tiling :

Rotation :  °

Picture Size :

w :  cm h :  cm

mirrored  mirrored

Move :

x :  cm y :  cm

Move with Element

All elements with a closed contour can be displayed filled.  
The following fill methods are available:

**Constant color:** Specify a fill color. The settings are the same as in the Change color chapter.

**Pattern transparent:** The area is filled with a bitmap hatching. The area between the hatching lines is transparent, the color of the pattern can be specified. A bitmap hatching is a predefined pattern. Compared to vector hatches (in Plan7Architect the Hatch property), bitmap hatches change their size when the display scale is changed.

**Pattern opaque:** behaves in the same way as pattern transparent except for the selectable background color.

**Linear gradient:** Two colors are defined. The filling of the object changes from the (start) color to the (target) color linearly along the horizontal dimension.

**Radial gradient:** Two colors are defined. The filling of the object changes from the (start) color to the (target) color radially within the dimensions.

**Circular gradient :** Two colors are defined. The filling of the object changes from the (start) color to the (target) color in a circle within the dimensions.

**Image:** Select the image file by clicking on the button . The path of the image file is entered in the corresponding field and the image is displayed as a fill. The size of the display is determined from the image file. The bottom left-hand corner of the image is displayed in the center of the drawing element.

If the image is a repeating pattern, the **Tile image** property is set to Tile. The image can be adapted to the contour of the element using the Image size, Rotation and Shift parameters. The dimensions of the image are specified in cm in the planning.

The image size and shift can also be changed in the drawing using the mouse.

Select the element, press the **[Shift]** key and click on the blue arrow symbol.

- on the blue arrow symbol for the width or height of the image to change the dimensions. Drag the image to the desired size.
- on the blue rotation arrows to determine the rotation
- on the blue circle in the center of the image to move it.

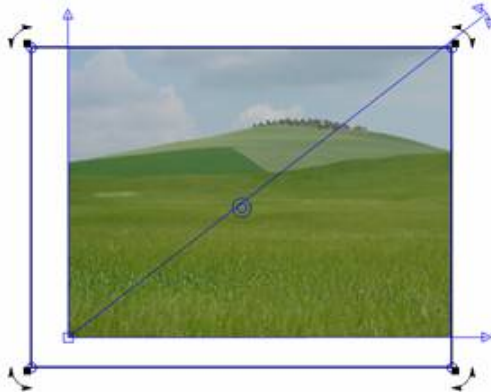

#### 4.4.2.3 Hatching

The Hatch property is used for all elements with a closed contour (e.g. closed polygon, ceiling, walls...) to display vector hatchings.

In contrast to the bitmap hatchings mentioned in the Fills chapter, vector hatchings are displayed with 2D drawing elements such as lines, arcs, etc. and are not just generated from images.

##### The advantages:

- Hatches can be modified using a wide range of parameters.
- Hatchings can also be displayed rotated.
- The display size of hatchings is variable.
- Hatchings can also be output when exporting (e.g. DXF).

##### Selecting the hatching pattern

Select the desired hatching from the selection list. The result is immediately displayed in the drawing.

##### Editing the hatching parameters

Click on the right arrow symbol > (Edit) next to the hatching displayed to open the **Hatching parameters** dialog :



**Direction follows object:** The orientation (rotation) of the hatching is defined via the Angle parameter. If the **Direction follows object** option is active, the object direction is used as the zero direction for the alignment of the hatching. The angle of the hatching is added to this direction.

This is advantageous, for example, when hatching wall layers that run parallel to the wall direction (insulation). Wall hatchings that run across several adjacent walls without a visible transition are created without this feature, as the hatching angle must be the same for all walls regardless of the wall direction.

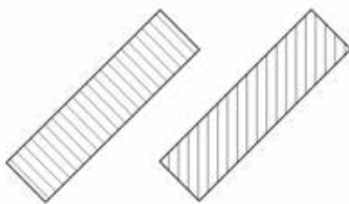

**Tile height = object height:** The tile height of the hatching adapts to the height of the object. The hatching pattern is only applied once in height. A typical application for this property is the representation of wall layers with the insulation hatching. This hatching should only be displayed once, regardless of the layer thickness.

**Tile size:** A hatch tile is the basic element of a hatch in which the pattern is defined exactly once. The rest of the hatching is created by repeating this tile. The size of the tile now determines how large the hatching pattern is displayed. The information is given in cm of the planning, but changes with the project scale. (If you change the scale from 1:100 to 1:50, the hatching will be displayed and printed more finely).

**Line type:** Select the line type of the hatching here. The line type refers to each individual element of the hatching; changing to a setting other than solid line is only necessary in special cases.

**Hatching colors and line widths:** Each hatching pattern is displayed with one color as standard. This is achieved with the *All identical* option. If individual elements are to be created with different settings, deselect the option and change the corresponding values.

**Proportions of the various components:** The hatching patterns available in Plan7Architect are parameterized. These parameters influence the distances, lengths and proportions of the hatching pattern.

#### 4.4.3 Line ends

Select the display for the start and end of the line. The size of the line ends depends on the line width.

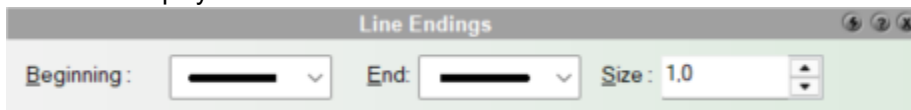

#### 4.4.4 Extend

The **Extend** property can be activated for the start and end of the line. Lines are then displayed as an infinite straight line. However, the start and end points remain at the same position.

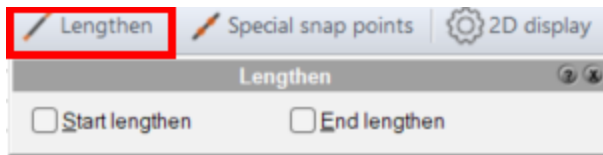

#### 4.4.5 Special catch points

In this dialog, you can specify for a line that intermediate points are also snapped to. The number is variable.



#### 4.4.6 Layer/Floor

Each element in the **drawing** is assigned to a **layer** and a **storey**. The storey is the storey that was the active storey when the element was drawn.

There are two ways of assigning layers:

- Elements such as walls, columns and dimensions are automatically assigned to a layer with the corresponding designation.
- Elements such as lines, texts and landings are stored on the active layer.

Further information can be found in the chapter [Structuring projects](#)<sup>103</sup>.

The layer and the storey of the element can now be checked or changed in the Layer/storey properties dialog. If the color of the layer is shown in red, elements of this type are automatically placed on this layer. If the selection list is not active, the layer is not intended to be changed (e.g. for walls). If you change the storey of the element, the height of components is also adjusted to the new storey.

A component that is not on an automatic layer can be assigned a different layer at any time:

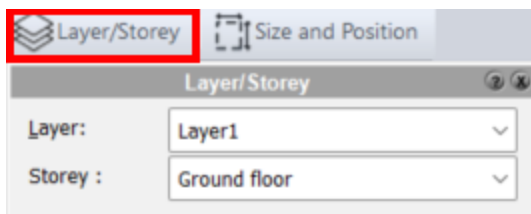

#### 4.4.7 Size/Position

The Size and position form allows you to specify the size of the element, the rotation and the position in the planning alphanumerically. Some of the parameters described are not available for all drawing elements.

Coordinates of reference points:		Reference points within a rectangular region:		
x:	-3478,707 cm	<input type="radio"/> 2	<input type="radio"/> 7	<input type="radio"/> 4
y:	2549,808 cm	<input type="radio"/> 5	<input checked="" type="radio"/> M	<input type="radio"/> 8
		<input type="radio"/> 1	<input type="radio"/> 6	<input type="radio"/> 3
Length:	717,107 cm			
Depth:	0,0 cm			
Rotation:	-77,32 °			
Rotation points relative to reference point:				
x:	0,0 cm			
y:	0,0 cm			

**The reference point (position):** The coordinates of the reference point are specified in absolute coordinates from the zero point of the planning. You can define the position of the element by entering new values. As calculation approaches can also be used in these fields, a shift by one value can be easily achieved by entering + 70 in addition to the existing value in the input field for the x-coordinate, for example. This moves the element 70 cm to the right.

The position of the reference point can be defined by selecting from the nine options.

If the drawing element is not rectangular, the circumscribing rectangle (maximum width and maximum height) is used for the position of the reference point.

**Size:** If the *Keep proportion* option is active, the original width/depth ratio is retained when the dimensions are changed.

If the drawing element is not rectangular, the circumscribing rectangle is defined again; you therefore change the maximum width and depth of the element with the width and depth parameters. All other points change proportionally.

**Rotation:** This parameter allows you to rotate the element around the pivot point. This pivot point is normally in the center of the circumscribing rectangle, but can also be moved with the corresponding values.

The pivot point can also be defined graphically:

Select the element and move the mouse cursor over the current pivot point.

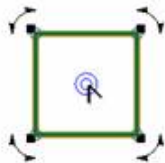

The mouse cursor changes as soon as you are over the pivot point. Now click on the point with the left mouse button and drag the pivot point to the desired position.

#### 4.4.8 Labeling

To assign a label to a component, click on the *Label* button in the properties bar:

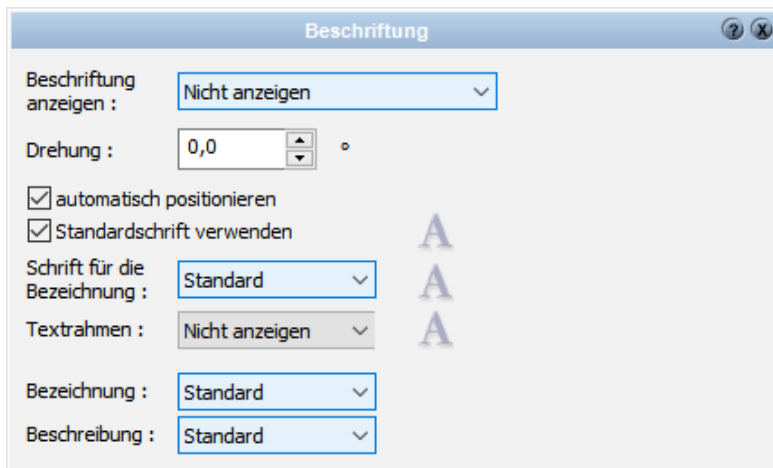

Here you can now set whether the label should be displayed/not displayed for a component, you can rotate the label, position it automatically and either use the default font or a custom font.

Labels/descriptions can also be displayed/not displayed here.

#### 4.4.9 Surface/Material

In this dialog, you can define the [material](#)<sup>436</sup> of the element in 3D mode.



#### 4.4.10 Properties

Specify the properties and labeling options of a component in this properties dialog

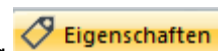

Eigenschaften

Eigenschaften Beschriftung

Bezeichnung	Wert	G	P	I.
<input checked="" type="checkbox"/> Außenputz	<input type="checkbox"/>			
<input checked="" type="checkbox"/> Folien	<input type="checkbox"/>			
<input checked="" type="checkbox"/> Innenputz	<input type="checkbox"/>			
<input checked="" type="checkbox"/> Lattung	<input type="checkbox"/>			
<input checked="" type="checkbox"/> Material nach m2	<input type="checkbox"/>			
<input checked="" type="checkbox"/> Material nach m3	<input type="checkbox"/>			
<input checked="" type="checkbox"/> Oberfläche	<input type="checkbox"/>			
<input checked="" type="checkbox"/> Schalung	<input type="checkbox"/>			
<input checked="" type="checkbox"/> <Im Report anzeigen>	<input type="checkbox"/> <Hat einen Wert>			

Eigenschaften

Eigenschaften Beschriftung

Bezeichnung	Wert	G	P	I.
<input checked="" type="checkbox"/> Belag	<input type="checkbox"/>			

Bezeichnung :  Kürzel :

Info :

Für alle Bauteiltypen verwenden

Private Eigenschaft

Liefert internen Massenansatz Einheit :

Massenansatz für  <keiner>

Werttyp :

Vorschlagswerte : 

Vorschlagswert	Kürzel	Farbe

Beschränkungen :

Untere Grenze

Obere Grenze

Standard-einstellungen :  Im Report anzeigen

Hat einen Wert

Eigenschaften

**Eigenschaften** **Beschriftung**

Eigenschaften anzeigen :

Drehung :  °  relativ

automatisch positionieren

Standardschrift verwenden 

Umrandung :  

Anzeige von Eigenschaften, die

nicht im Report verwendet werden	<input type="text" value="Standard"/>
keinen Wert haben	<input type="text" value="Standard"/>
nur Standardwerte sind	<input type="text" value="Standard"/>

#### 4.4.11 Position number

Assign an position number to a component:

Entering the position number in the **PosNr** properties dialogue  
 If the element is selected, open the **PosNr** properties dialogue:

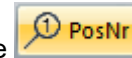

 A screenshot of the "PosNr" properties dialogue window. The window has a title bar with "PosNr" and standard window controls. The main area contains several fields and checkboxes:
 

- PositionsNr :** A text input field containing "001" and a small gear icon to its right.
- PositionsNr anzeigen :** A dropdown menu set to "Standard".
- Drehung :** A numeric input field with "0,0" and a "relativ" checkbox that is checked.
- automatisch positionieren** with a dropdown menu set to "<Globale Einstellu".
- Standardschrift verwenden** with a preview of the letter "A".
- Umrandung :** A dropdown menu set to "Standard" with a preview of the letter "A".
- Globale Form verwenden** with a dropdown menu set to "Rechteck".
- Linie zum Bauteil :** A dropdown menu set to "Standard".
- Stammdaten anzeigen :** A dropdown menu set to "Standard".

The position number can be changed or entered in the corresponding input field.

The maximum number of characters is 64, so instead of an position number you could also enter descriptive information, e.g. "External wall NO".

In addition, the rotation and the display options for font, border and positioning can also be set in this dialogue.

positioning can also be set in this dialogue (only valid for the selected element). A line to the component can be displayed

as well as the master data of the component.

#### 4.4.12 Light source

Define different light sources for 3D objects.

Depending on the type of light source, you have numerous different options for illumination available to you.

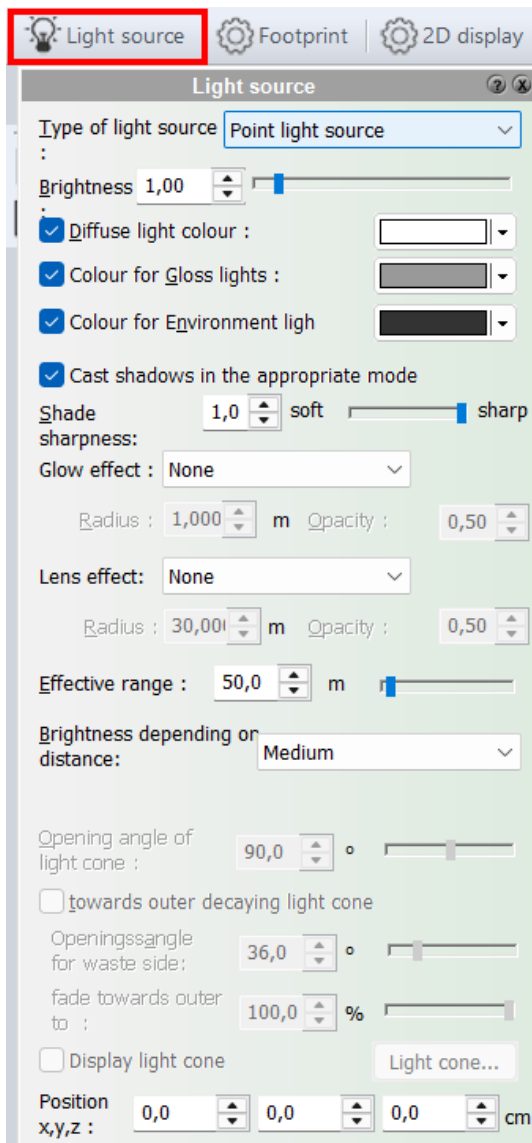

Type of light source:

- Point light source
- <no light source>
- Directional light source
- Point light source
- Emitter

**Options:**

- No light source
- Directional light source
- Point light source
- Emitter

## 4.4.13 Component catalogs

### 4.4.13.1 Catalogs - Component templates

The following drawing elements support catalogs with component templates:  
Walls, virtual walls, windows, doors, recesses, stairs, railings, chimneys, columns, joists, beams, ceilings, roofs, dormers, sky lights, slabs, i.e. all components except ceiling recesses.

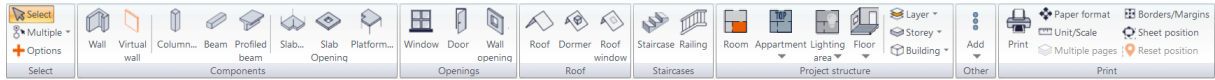

In addition to the above-mentioned components, **templates** are also available for lines, polygons, texts and dimension lines.

#### 4.4.13.1.1 What are component templates?

A **component template** is an entry in the catalog. All relevant parameters of a component are saved in a component template for reuse. Before drawing a new element, the user can set all values for this component type by selecting the corresponding component template. If an element has already been drawn, all values and parameters of the element are adjusted to those of the new component template by reassigning a component template.

Component templates are saved in databases and are available across all projects.

#### 4.4.13.1.2 Save new component template

To create a new **component template**, it is important to place a component in the planning, for example a wall, then activate it with the left mouse button and make the changes. For components that have different representations in the various levels of detail, it must be ensured that the [level of detail view](#)<sup>[216]</sup> is selected accordingly beforehand so that the changes made can be recognized immediately on the drawn component!

Change to the directory in which the component template is to be saved. Click on the **Create new element** button. A dialog opens in which you can enter the name, description and preview for this component template. You can use the > button to select a different preview image if necessary. Enter the name and click **OK**. The current settings of the properties dialogs at the time the part template is saved are therefore transferred to the part templates. It is also very easy to save the values after a wall to be designated as a component template.

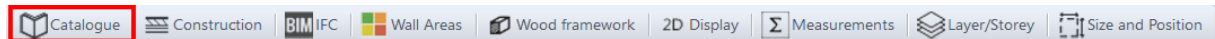

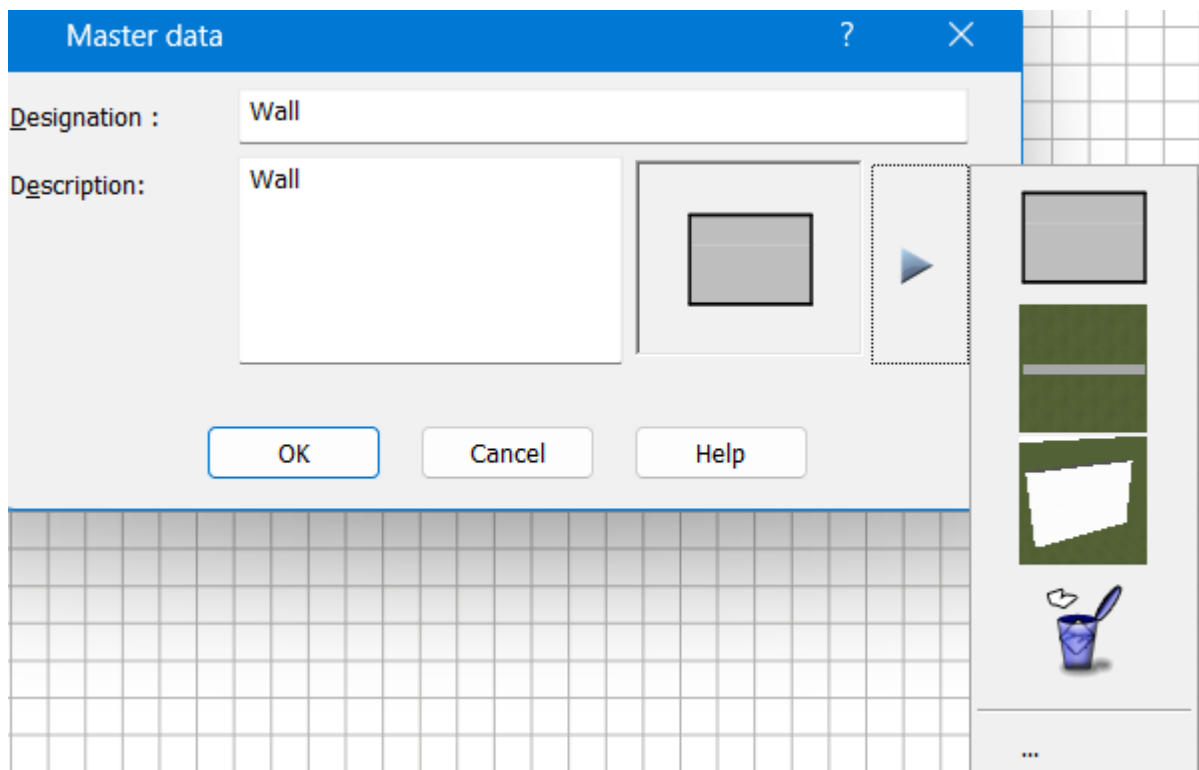
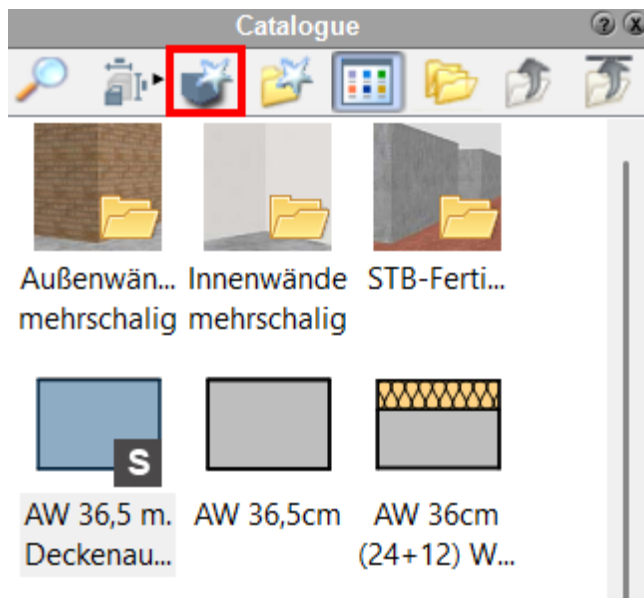

#### 4.4.13.1.3 Deleting a component template

Open the catalog, right-click on the component template to be deleted and select **Delete** from the context menu.

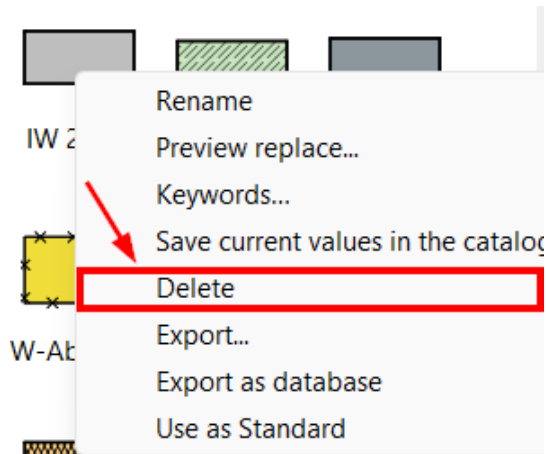

## 4.4.13.1.4 Save current values

An existing component template can be overwritten with current values. Click on the **Wall** button, edit the values and parameters in the properties dialogs, open the catalog, right-click on the component template to be overwritten and select **Save current values** in the context menu.

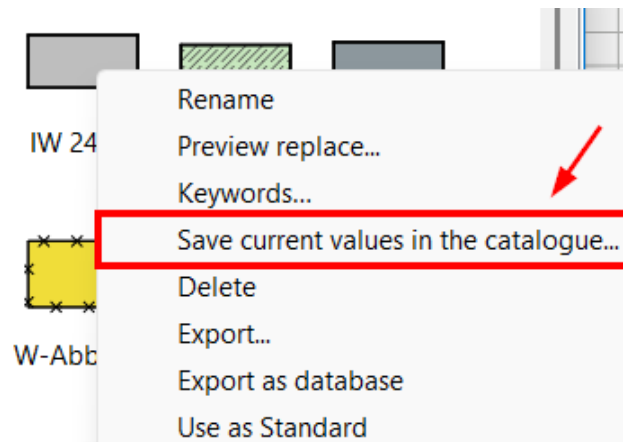

The same dialog opens as when creating a new part template. You can edit or select the name, description and preview image.

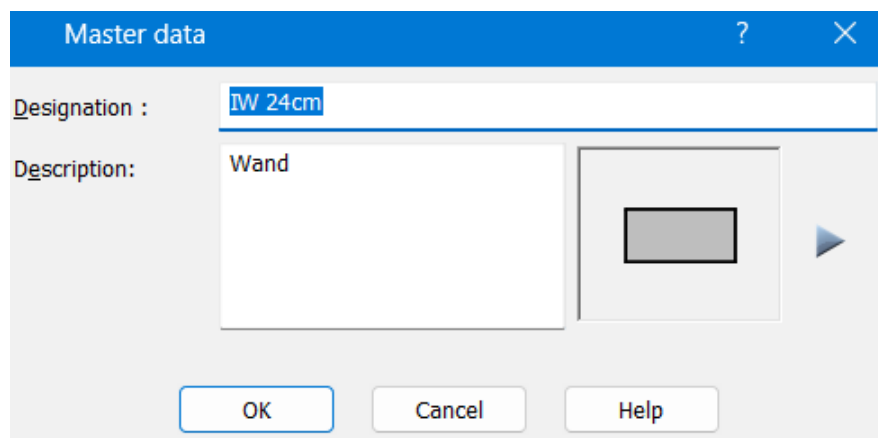

## 4.4.13.1.5 Move component templates to another directory

Click on the part template in the list view of the catalog and drag the part template to the corresponding directory in the list view or the tree structure by holding down the left mouse button.

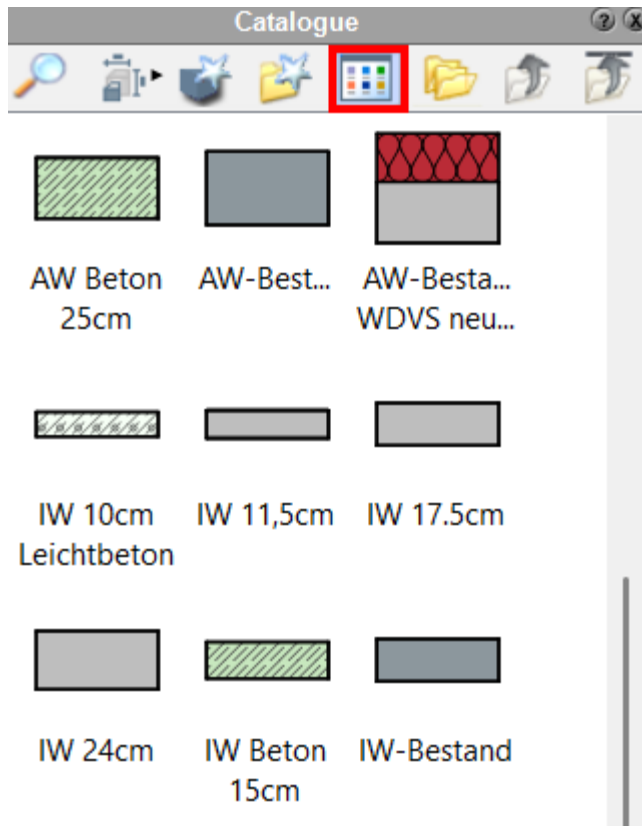

## 4.4.13.1.6 Standards

One component template is always marked as the default for each component type. The default entry is marked with an **S** on the preview image. The default part template is the template that is suggested by the system as long as the user has not selected a specific template.



Right-click on a template and select **Use as default** in the context menu.

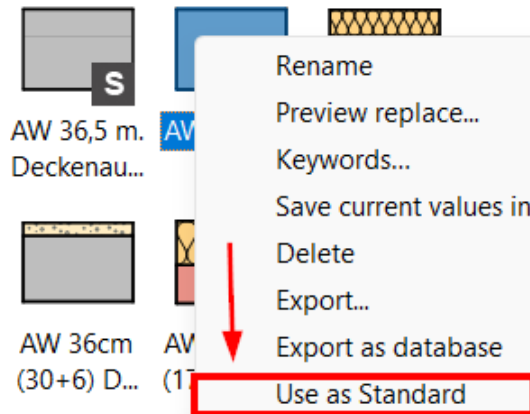

#### 4.4.13.1.7 Databases for component templates

Component templates are stored in [databases](#)<sup>[168]</sup>. The division, structure and number of these databases is largely up to the user. For example, the catalog for the component templates for doors can be created from several databases. However, it is important for the user to know in which database the new component templates are saved.

This can be set in the menu **Options|Select databases for saving...** menu in the top right corner. If you change an existing part template using the **Save current values** function, the part template will of course remain in the original database.

When saving a template, the database in which the template is stored is displayed (unless this option has been deactivated). If you click on an existing template, the database (incl. path) in which this template is located is also displayed in the info line.

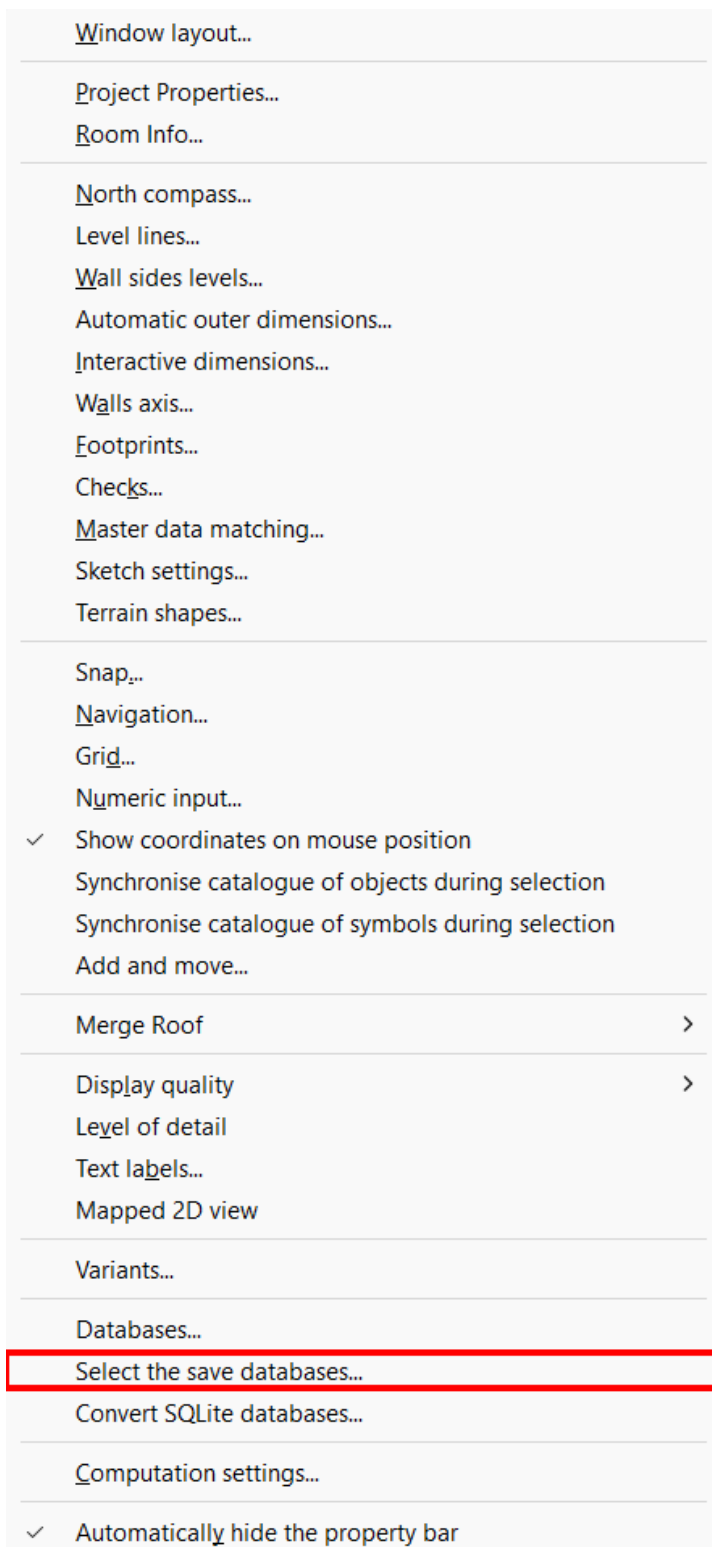

When saving a template, the database in which the template is stored is displayed (unless this option has been deactivated).

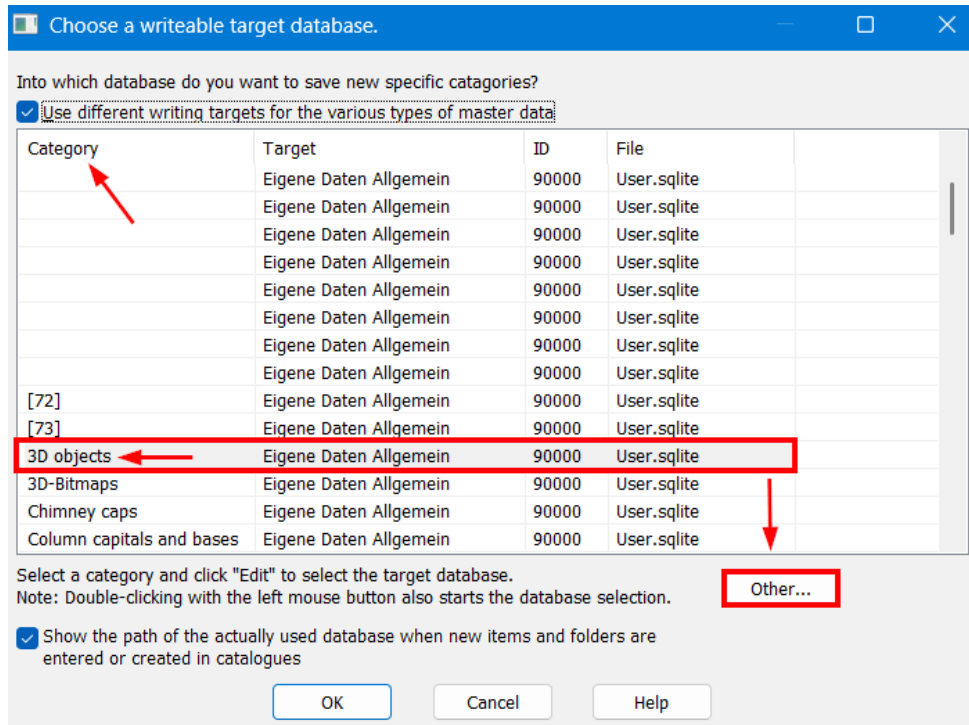

First click on a **category** in the list in which you want to save. Then select the target database by clicking on the **Change** button :



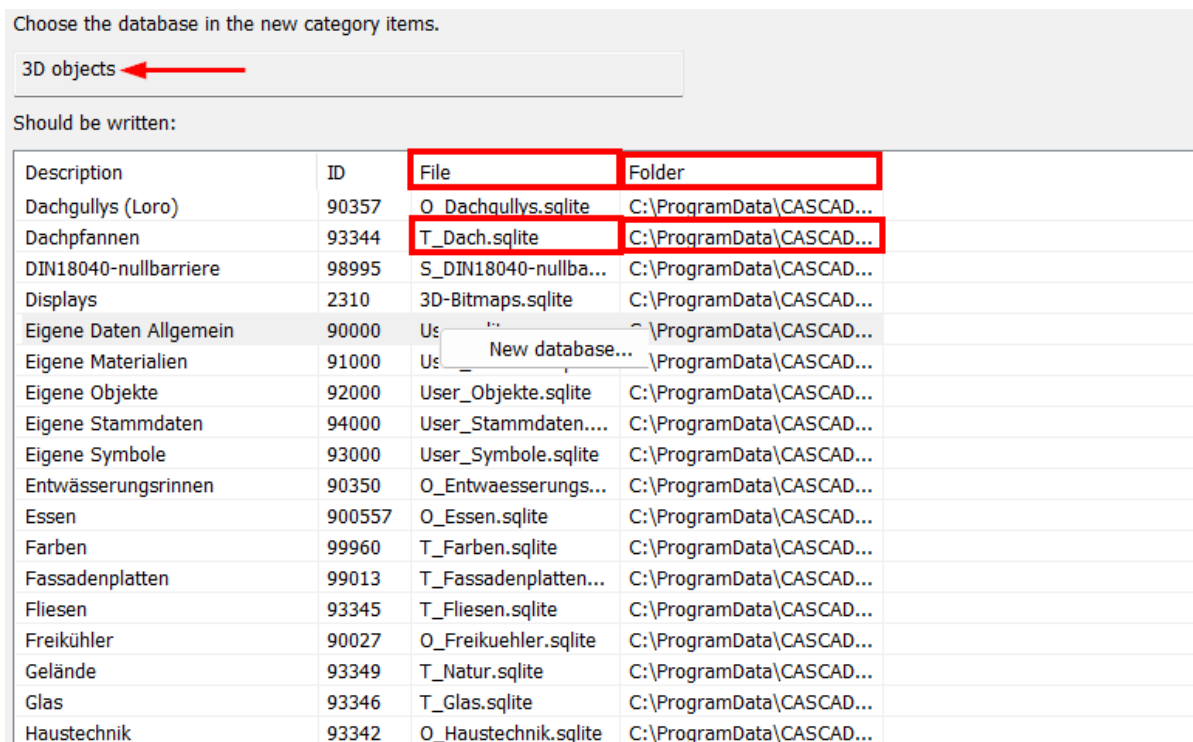

By double-clicking on an existing category, the database (incl. path) in which the template is located is also displayed in the info line.



#### 4.4.14 Catalog Explorer

The object explorer is displayed with the button  of the explorer bar  .

The content is divided into folders and subfolders. All folders are marked with the symbol  . Objects only show the preview image.

The view of the content area can show small or large preview images. Switch between the two options using the button  **Details**.

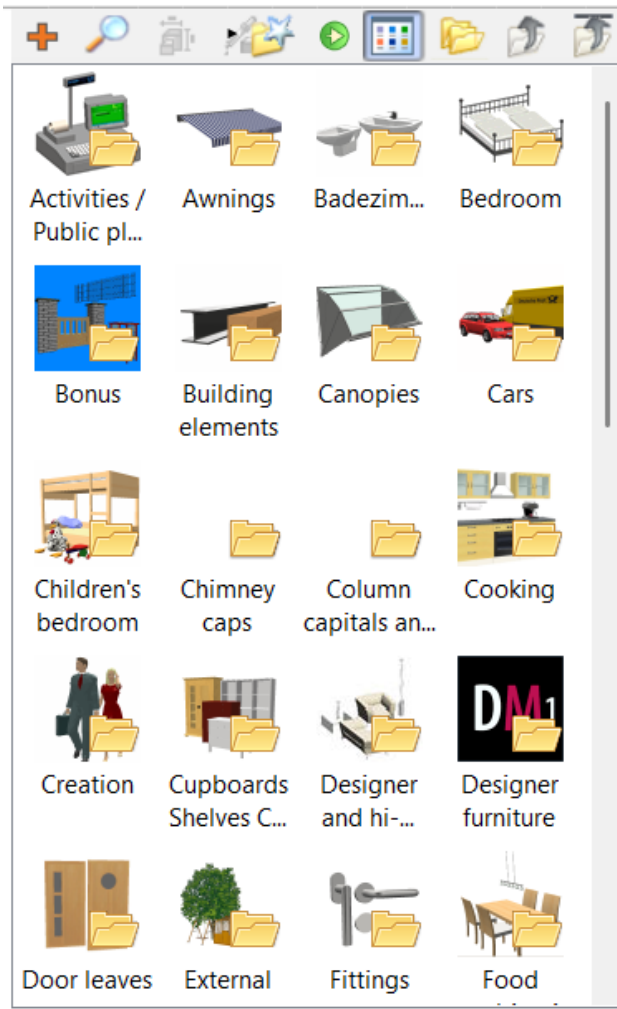

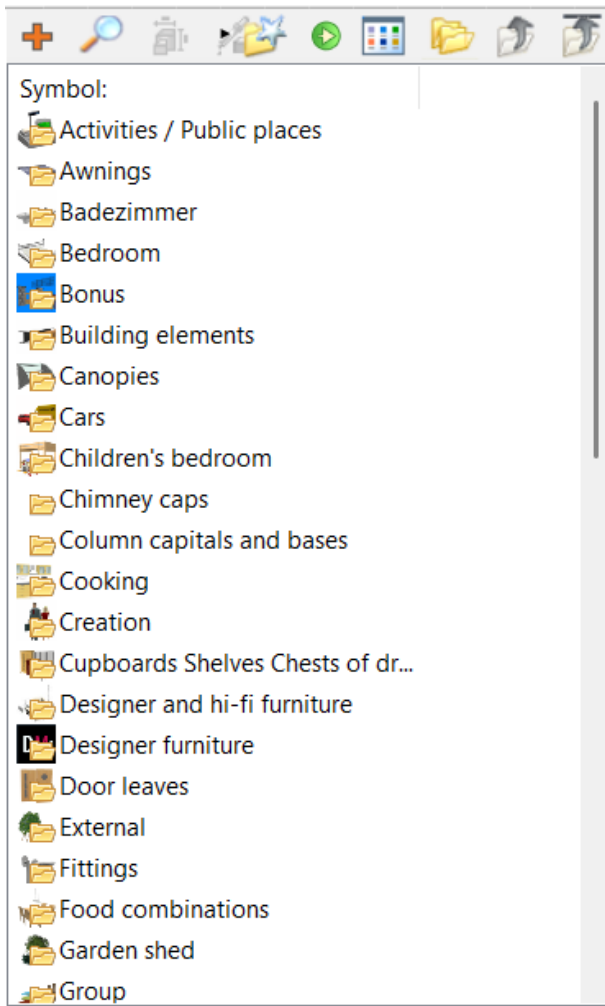

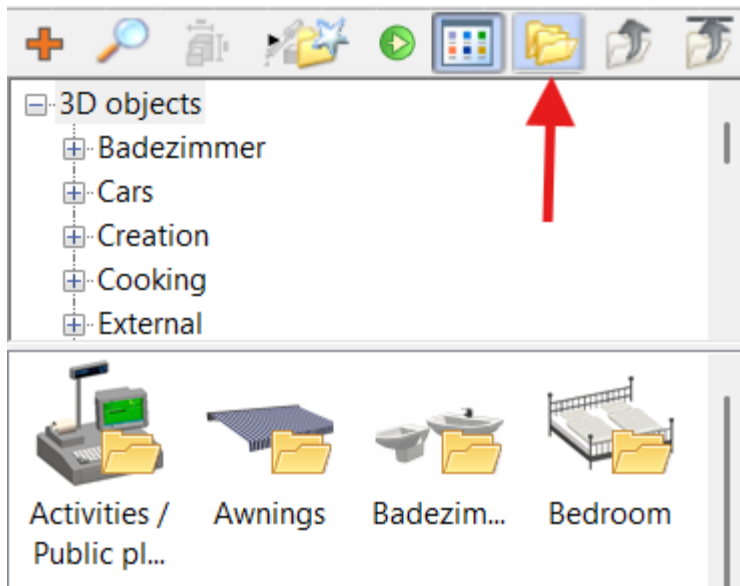

### Show folder structure as a tree

The folder structure can also be displayed as a tree. To do this, click on the button  **Show folder** in the Explorer. The structure is displayed in the upper area.



### Change folder

Double-click on the desired folder in the content area or click on the folder in the folder structure. The folder is opened and the contents are displayed.

Use the button  **Move up one folder** to switch back to the parent folder. The button  **Go to top folder** takes you back to the top of the structure.

#### 4.4.14.1 The content area

### Create a new folder

Click on the button  **Create new folder**.

A dialog appears, please enter the name and select a suitable preview image. The new folder is created within the current folder.

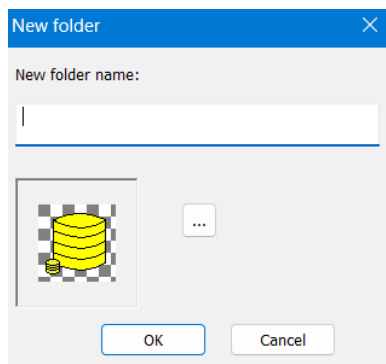

### Edit folder

Click on the folder in the content area and press the right mouse button. Select **Edit** in the context menu. You can now change the preview image and edit the folder name.

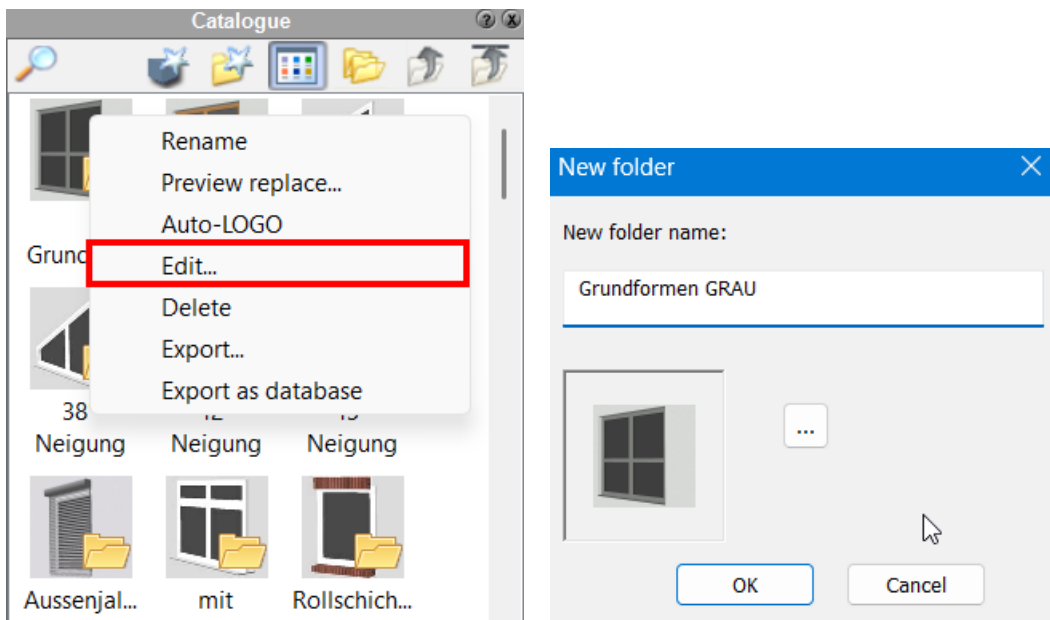

### Delete folder

Click on the folder in the content area and press the right mouse button. Select **Delete** in the context menu. The folder and all the objects it contains are now deleted from the database.

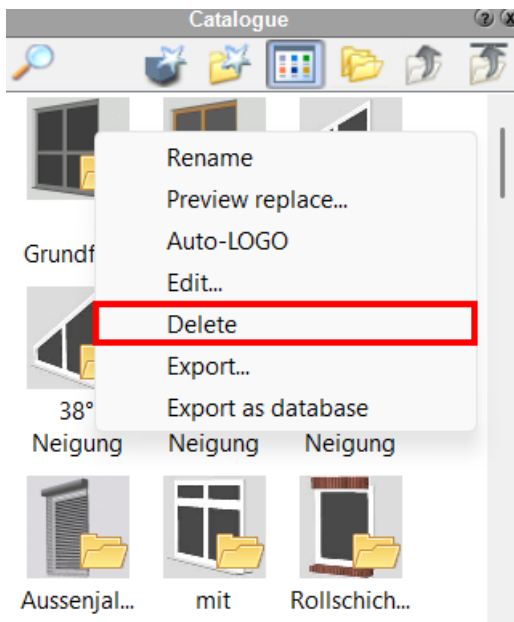

### Move folder

Click on the button  **Show folder** to display the folder structure as a tree. Click on the relevant folder and, holding down the left mouse button, drag it to the folder in the tree view in which the folder should be located.

### Save object

Drag the 3D object from your scene to the content area of the catalog.

Now enter the name for the object and press **OK**.

#### Delete object

Click on the object in the content area and press the right mouse button. Select **Delete** in the context menu. The object is now deleted from the database.

#### Move object

Click on the relevant object and, holding down the left mouse button, drag it to the folder in the tree view in which the object should be located.

#### Additional folders - Show external files in the catalog

This option is available by right-clicking in an empty area of the catalog and selecting **More folders** in the context menu. A dialog for selecting a directory opens. Select the desired directory and confirm your selection with **OK**.

All 3D object files (c3D, aco, o2c, 3ds) in this directory and its subdirectories are read and integrated into the object catalog as a structure.

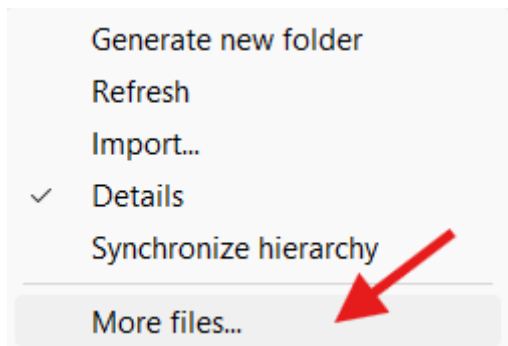

After a restart, the directory is displayed in your catalog and remains logged in for all further editing. Each folder integrated in this way is always displayed at the top level of the structure. Several directories can also be integrated into the catalog if required.

To remove the folder from the catalog again, right-click on an empty area of the catalog and deselect the folder in the context menu. A message appears stating that the change will only be visible after restarting Plan7Architect.

External objects are not always saved with the necessary textures; these are located outside the file, as is the case with the aco file format. Set the search path for textures from other programs in the **Options|Import...** menu .**Search paths** tab.

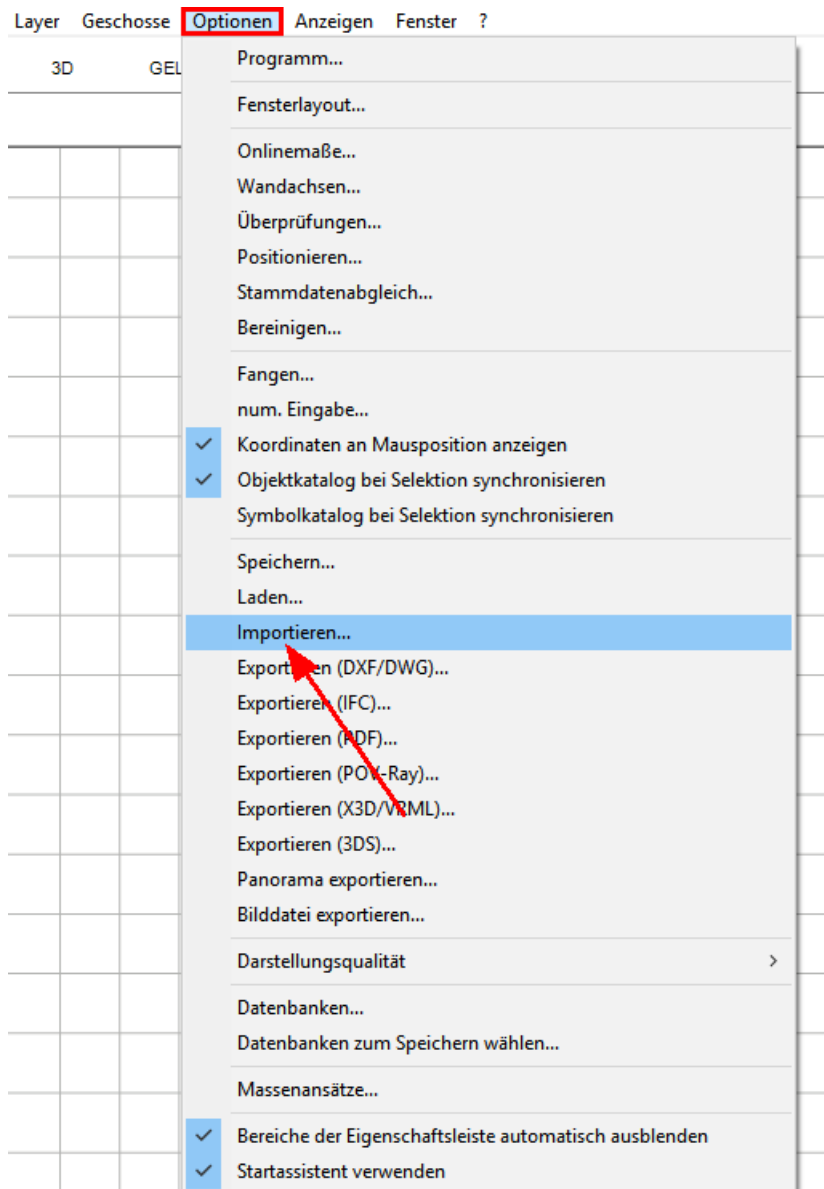

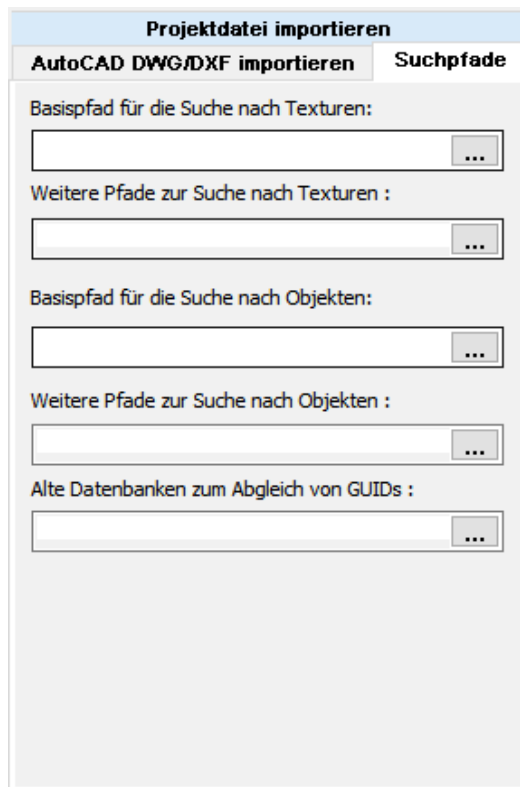

#### 4.4.14.2 Search

You can search across folders in the catalogs in the Explorer. This is useful, for example, if you want to find all symbols or objects relating to the topic 'Table':

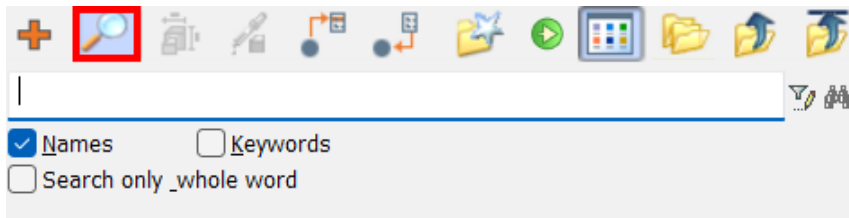

To do this, activate the magnifying glass symbol  and enter the keyword and/or name + press **[Enter]**. All entries will then be listed

## 5 Options

General properties can be defined in the **Options** pull-down menu. These are also stored in **standard.cad**.

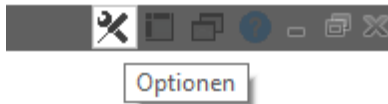

see --> [Program](#)<sup>68</sup>

see --> [Window layout](#)<sup>192</sup>

see --> [Wall axes](#)<sup>223</sup>

see --> [Numerical input](#)<sup>227</sup>

### 5.1 Online dimension settings

You can find the settings in the menu under **Options|Online dimensions**. The general default settings for the **online dimensions** can be made here.



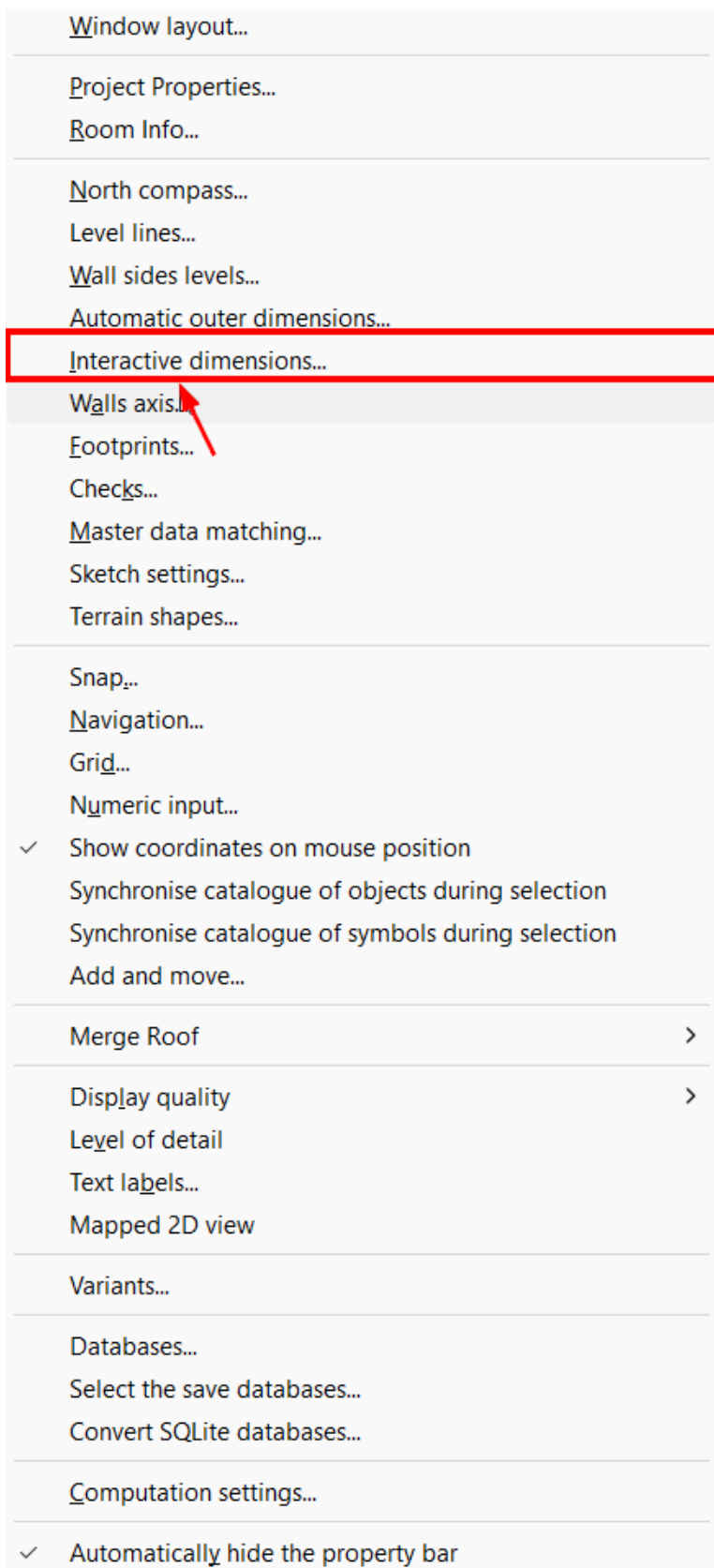

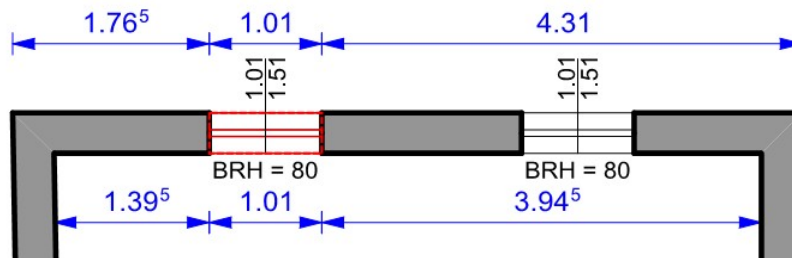

Interactive dimensions ? X

Measured value	Dimension line
Witness line extensions	Wall length
Interactive dimensions	Interactive dimensions in 3D

- Use interactive dimensioning for entry
- Use interactive dimensions
- Interactive dimensions are changeable
- Width and Height Measurements
- Position interior from room measurements.
  - Only dimension the middle point.

Maximum distance to wall :  cm

Dimension both adjacent walls. ▾

Special

- Windows  Dimensions on axis
- Roof windows  Dimensions on axis
- Dormers  Dimensions on axis
- Roofs  Staircases
- Rooms  Walls

OK Cancel Help

see also -->[Online dimensions](#) <sup>1801</sup>

## 5.2 Options\_Catch

The settings for **snapping** can be made here. The function is called up in the menu bar under **Options|Snap...** in the menu bar:

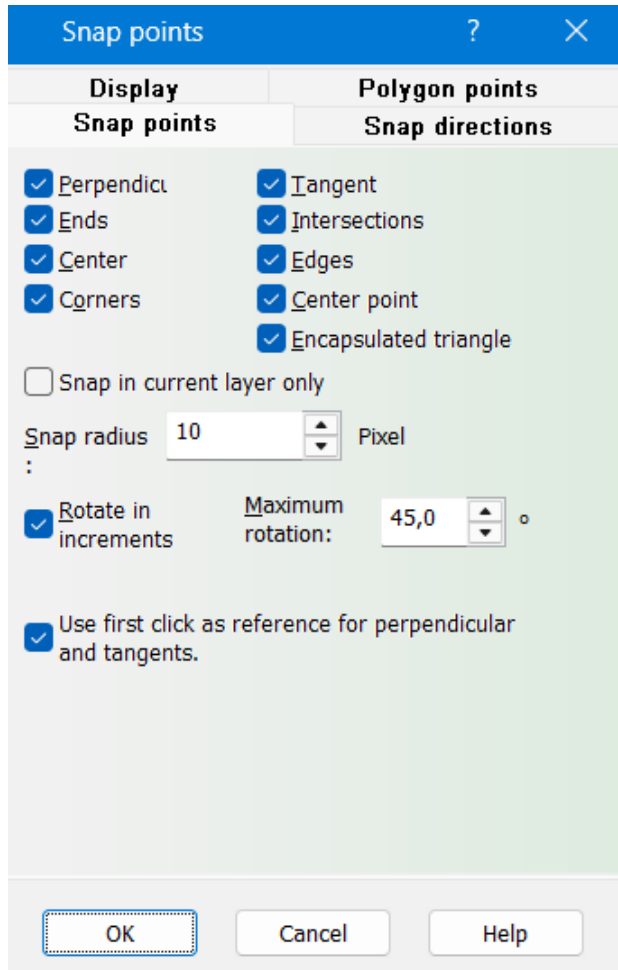

see also --> [Catch](#)<sup>176</sup>

## 5.3 Databases

In Plan7Architect, databases are used for the following elements:  
3D objects, materials, symbols: These elements are displayed in folders in the corresponding explorers.

Master data for all components (walls, windows, doors, ...): The master data for the individual component types can be found in the corresponding catalogs.

All databases logged into the system are listed in the **Databases** dialog. In the standard configuration, all databases from the directories ...Plan7Architect\**Databases** and...Plan7Architect own **databases** are registered.

The **databases** directory contains all catalogs that are delivered with Plan7Architect as a library.

All databases with O\_ are databases for 3D objects.

All databases with T\_ contain all materials.

All databases with S\_ contain all symbols.

In addition, the databases *Master data* (for all supplied master data) and *System* (north arrow, standard material, etc.) are stored in the *Databases* directory.

Your individually created elements are saved in the **Own databases** directory. The following databases are created for this purpose:

User_Objects	for your own 3D objects
User_Material	material you have created yourself
User_Symbols	your symbols
User_Master_data	all master data you have created yourself
User	for dimension lines and texts and automatically created indices, for internal use only

The **Own databases** directory therefore contains user data and should be backed up regularly. The path to the **user's own databases** can be changed using the **Base path** button.

In the file Plan7Architect.ini you will find these entries in the section [DB]

[DB]

Directory0=Own databases

Directory1=Databases

UserWriteDB=Own databases\User.sqlite

Experienced users can also change the entries in this file manually.

(The file Plan7Architect.ini is usually located in the folder: C:\ProgramData\Plan7Architect)

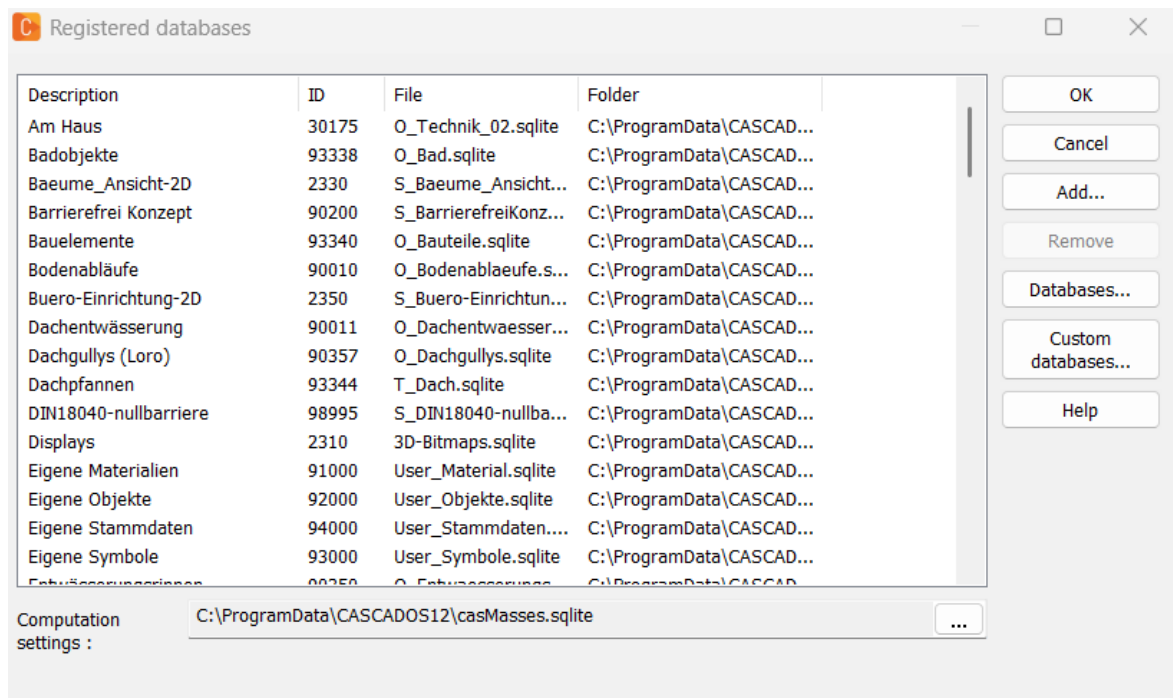

In the **Options|Databases** dialog you will see a list of all currently loaded databases.



Databases...

The path for **your own databases** or the **databases** can be defined using the two buttons.

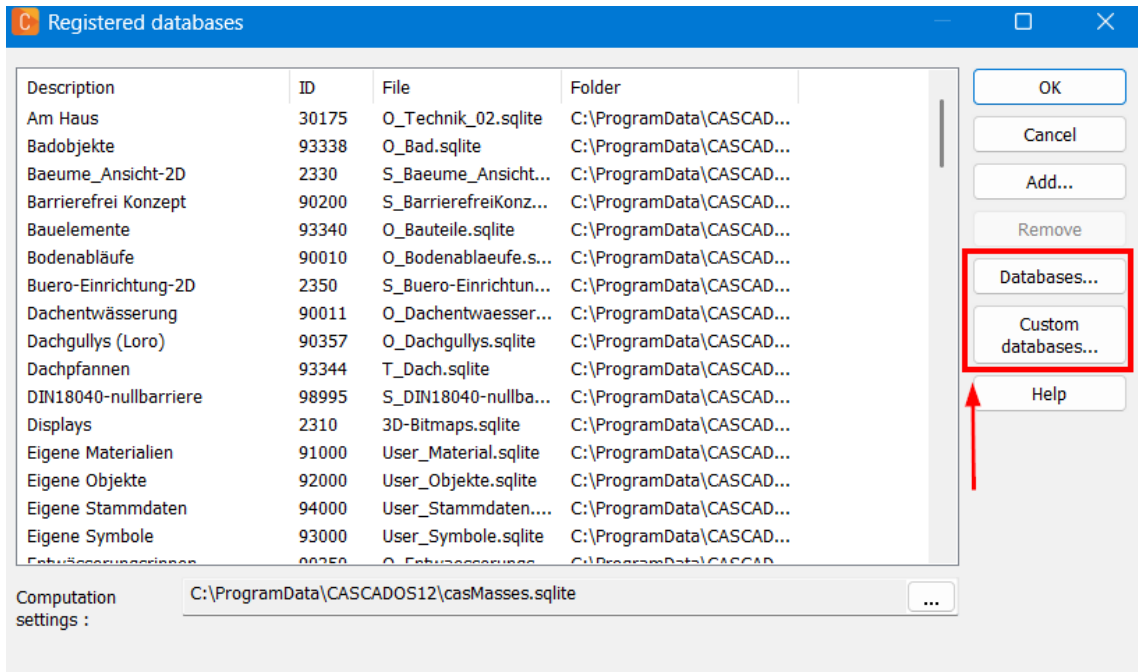

### 5.3.1 Select databases for saving

You can find this command in the menu bar under *Options|Select databases to save...*

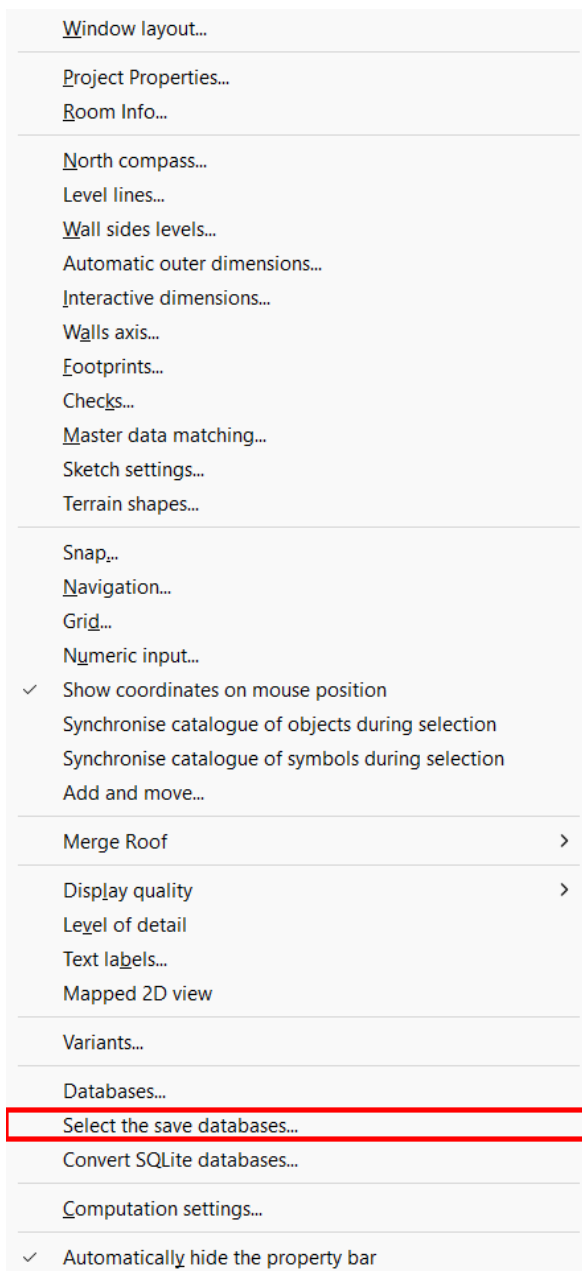

For each element category, select the database in which newly created elements are to be saved. Changes to existing elements are saved in the database in which the element was originally created. Click on the line of the category and click on the **Change** button.

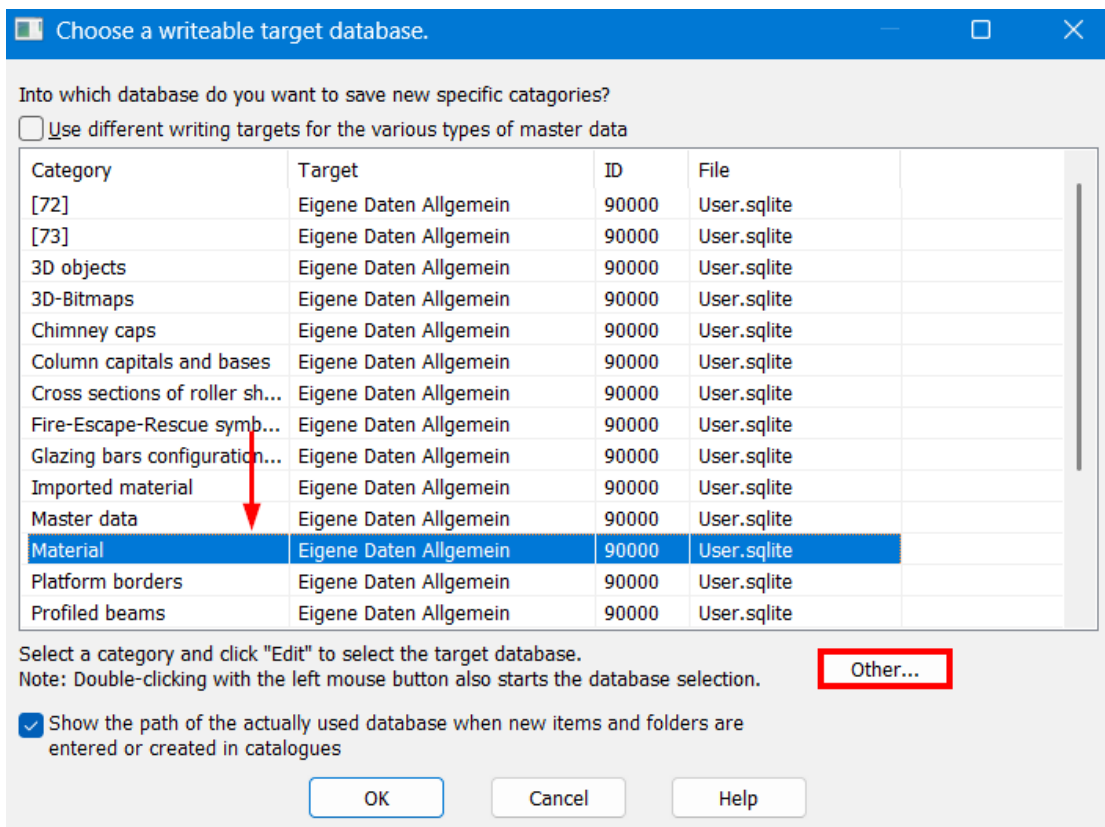

Any registered database can be selected in the dialog that now appears. A new database can be created with the **New database** command. To do this, first enter the name of the database file. Make sure that the database is also located in the correct directory.

Wählen Sie die Datenbank aus, in die neue Einträge in der Kategorie

3D Objekte

geschrieben werden sollen:

Beschreibung	ID	Datei	Verzeichnis
Am Haus	30175	O_Technik_02.mdb	C:\ProgramData\CasCAD...
Aussenleuchten	30090	O_Leuchten_ausse...	C:\ProgramData\CasCAD...
Autos	30010	O_Autos.mdb	C:\ProgramData\CasCAD...
Badobjekte	93338	O_Bad.mdb	C:\ProgramData\CasCAD...
Baeume_Ansicht-2D	2330	S_Baeume_Ansicht...	C:\ProgramData\CasCAD...
Bauelemente	93340	O_Bauteile.mdb	C:\ProgramData\CasCAD...
Buero-Einrichtung-2D	2350	S_Buero-Einrichtun...	C:\ProgramData\CasCAD...
Büro	30040	O_Buero.mdb	C:\ProgramData\CasCAD...
Dachpfannen	93344	T_Dach.mdb	C:\ProgramData\CasCAD...
Dekoration Raumausstattung	30050	O_Dekoration_Rau...	C:\ProgramData\CasCAD...
Diele	900350	O_Diele.mdb	C:\ProgramData\CasCAD...
Eigene Daten Allgemein	90000	User.mdb	C:\ProgramData\CasCAD...
Eigene Materialien	91000	User_Material.mdb	C:\ProgramData\CasCAD...
Eigene Objekte	92000	User_Objekte.mdb	C:\ProgramData\CasCAD...
Eigene Stammdaten	94000	User_Stammdaten....	C:\ProgramData\CasCAD...
Eigene Symbole	93000	User_Symbole.mdb	C:\ProgramData\CasCAD...
Essen	900557	O_Essen.mdb	C:\ProgramData\CasCAD...
Farben	99960	T_Farben.mdb	C:\ProgramData\CasCAD...
Fassadennlatten	99013	T Fassadennlatten...	C:\ProgramData\CasCAD...

Hinweise:

- falls in der obigen Liste nicht alle Datenbanken angeboten werden, sind die fehlenden Datenbanken schreibgeschützt.
- Doppelklick mit der linken Maustaste auf eine Datenbank wählt diese aus und schließt den Dialog.

OK Neue Datenbank... Abbrechen Hilfe

The name and database ID are entered in the next input screen.

Datenbank-ID: 90000

Hinweis: Datenbank-IDs dürfen nur einmal vergeben werden. Sie können keine zwei Datenbanken mit der gleichen ID gleichzeitig anmelden.

Name der Datenbank:

OK Abbrechen Hilfe

The database ID is already suggested with a unique number. Only enter each ID once.

## 5.4 Zoom, Screen layout and Drawing aids

### 5.4.1 Selection

Make sure that the layer of the element to be selected is not protected. If necessary, check the setting in the layer management.

To select an element, the selection pointer  of the construction barmust be active. If no other function is active, the pointer is automatically active.

#### Selecting a single element

Click on the element with the left mouse button. If it is then selected, the element's properties dialogs appear and the element is displayed with the selection frame. If the element is under another element, you can click on the same position several times and the selection will switch between all accessible elements.

#### Draw area

If no element is clicked directly, an area can be expanded by holding down the left mouse button. All elements in this area are selected.

In the input options of the selection pointer, you can select whether only elements that lie completely within the defined area are selected. If this option is not active, all elements with at least one point in this area are selected.

If the **[Ctrl]+[SHIFT]** keys are also pressed before the first input with the left mouse button, the selection can be made by polygon.

#### Selecting further elements

Press the **[Ctrl]** key during selection to add further elements to the current selection.

#### Edit/Markup

In the *Edit/Mark* menu, the selection can be made according to the following criteria:

All: Selects all elements on unprotected layers and floors

Active layer: All elements of the active layer

Other layer: All elements of a layer that is selected

Active projectile: All elements of the active projectile

Other storey: All elements of a storey that is selected

Group: Select the group(s) from the selection list

Deselect: The current selection is deselected

Invert selection: All selected elements are no longer selected, but all unselected elements are selected.

#### Tool options for the selection:

Also move unselected elements with the mouse: If this option is activated, you can click on an element with the left mouse button and also move it immediately by holding down the mouse button.

Drawn rectangle: You can also draw rectangles with the selection arrow (without selecting an element with the first click). This rectangle can be used to perform either the Zoom window command or an area multiple selection.

When selecting a range, you can also specify the circumstances under which elements that are only partially in the range are also selected.

Select here: No - all elements (even those only partially within the range) are selected

Yes - Only elements that are completely within the range are selected

When entering from left to right - If the first point of the rectangular area is on the left, only elements lying completely within the area are selected; if the first point is to the right of the second, all elements are selected.

Which dialogs are displayed when an element is selected?





















All - the dialog bar (the frequently used properties) and the properties bar are displayed

Dialog bar - only the dialog bar is displayed  
None - only the element is selected.

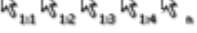
All dialogs are always displayed when:

- an element is selected by double-clicking
- an element is selected and you press the **[Alt]** key
- an element is selected and you press the **[Enter]** key

### The different forms of the cursor

-  **Selection mode:** If selection mode is activated, the mouse pointer is a normal arrow. When selecting elements, the selection arrow changes when you use the **[Ctrl]** or **[Shift]** key; a plus sign is also displayed.
-  **Selection mode:** If an element is selected, the mouse pointer changes as soon as it is positioned over the selected element. You can move the selected element in any direction.
-  **Selection mode:** If you move the mouse pointer over the corners of the surrounding rectangle of a selected element, the mouse pointer changes. You can scale the selected element by holding down the left mouse button.
-  **Selection mode:** If you move the mouse over one of the rotating arrows, the mouse pointer changes. You can rotate the selected element in any direction by holding down the left mouse button.
-  **Zoom in:** If you have activated the *Zoom in* function, the mouse pointer changes to 
-  **Zoomout:** The mouse pointer changes to  when you select the *Zoom out* function
-  **Zoom in:** If you select the *Zoom in* function, the mouse pointer changes to 
-  **Zoom to element:** If you have activated the *Zoom to element* function, the mouse pointer changes to 
-  **Selecting elements while using a tool:** If you activate a tool that requires the selection of an element as an input step (e.g. Move), the mouse pointer changes to 
-  **Input steps:** If you activate a tool, the required input steps are displayed on the mouse pointer. The first number is the currently required input step, the second is the total number.
-  **Move windows, doors, wall openings:** If you click on an element that has already been inserted, the changed mouse pointer indicates that this element can now be moved within the wall.
-  **Move pivot point:** The pivot point of an element is shown by a blue circle. If you move the mouse over this pivot point, the mouse pointer changes accordingly. You can now move the pivot point by holding down the mouse button.
-  **Move special points:** To change the [geometric properties](#)<sup>[174]</sup> of an element, squares are displayed around the points of a selected element in addition to the selection frame, which you can change individually (e.g. all corner points in the case of a polygon course). If you move the mouse over these points, the mouse pointer changes.
-  **Texture shift:** If a selected element is filled with an image, you can rotate it in any direction using the rotation arrow in the coordinate system. After you have clicked on the center point in the rotation arrow using the **[Shift]** key, the mouse pointer changes accordingly.
-  **Texture shift:** If a selected element is filled with an image, you can shift it in the x-direction using the right arrow in **the coordinate system**. After you have clicked on the arrow using the **[Shift]** key, the **mouse pointer changes accordingly**.

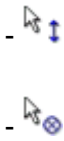

**Texture shift:** If a selected element is filled with an image, you can shift it in the y-direction using the upper arrow in the coordinate system. After you have clicked on the arrow using the **[Shift]** key, the mouse pointer changes accordingly.

**Texture shift:** If you click on the origin of the coordinate system for a selected element, the mouse pointer changes and you can shift the origin of the texture coordinates.

## 5.4.2 Zoom and pan (move)

The three most important zoom functions are available as buttons in the standard toolbar:



**Zoom section (Z):** You define a section of the image using two points.



**Show all (0):** The section is selected so that all visible drawing elements are displayed as large as possible on the screen.

### ***Zoom with the scroll wheel of the mouse***

If you turn the scroll wheel of the mouse downwards, the image section is reduced; if you turn the wheel upwards, the section is enlarged.

The current mouse pointer position is used as the center for zooming with the scroll wheel.

### ***Pan with the mouse (2D mode)***

Hold down the middle mouse button (or the scroll wheel) of the mouse and drag the image section to the desired position.

### ***Pan with the mouse (3D mode)***

Hold down the middle mouse button (or the scroll wheel) and drag the image section to the left, for example, and the model will turn to the right.

The mouse position is your 'eye' which moves. If you drag the mouse upwards while holding down the button, the model will tilt downwards.

**If you only want to move the model (without tilting or rotating), then press the 'CTRL' key while moving the model with the middle mouse button held down!**

### ***Keyboard shortcuts:***

**+** and **-**: Enlarges or reduces the screen section centrally

**\*** and **/**: Enlarges or reduces the screen section centered on the current mouse pointer position

**0**: The 0 key on the numeric keypad corresponds to the *Show all* function

**1 - 9**: Use the keys 1 to 9 on the numeric keypad to move the drawing in the direction corresponding to the position of the key on the numeric keypad. (1 for example to the bottom left)

The cursor keys (left/right/up/down arrow) move the drawing in the respective direction. in the respective direction.

## 5.4.3 Catch

The snap function of Plan7Architect offers you the possibility of considerably simplifying the input and editing of elements.

Each existing element in your drawing consists of many points. A line, for example, has end points, a center point, quarter points, ...





Two intersecting lines also have an intersection point. Circles have center points, walls have corner points, axis points, etc.

You can elegantly use these points of already drawn elements for further work. To do this, move the mouse cursor over a drawn and visible element during input. The cursor display changes at the points

where Plan7Architect can snap to. A simple click with the left mouse button takes over the exact coordinates of the snap point.

### Which points can be snapped

The mouse pointer shows which type of point is currently being snapped.

- **End points:**  all end points of lines, arcs and circles, walls etc.
- **Corner points:**  all corner points of polygons, N-corners, etc.
- **Center points:**  the center points of lines, wall sides, etc.
- **Object center point:** (no special mouse pointer) the center point of the enveloping rectangle of the selected element. By pressing the **W** key (even several times), you can snap to the center point when placing, moving, etc.)
- **Intersection points:**  the intersection point of two drawing elements
- **Perpendicular points:**  The perpendicular point of the working point or the first point entered is snapped to contours.

### Precise snapping

With detailed, extensive drawings, snapping is often difficult if the display scale is too large and the number of elements is too high. To ensure that the desired point is snapped, this section should be zoomed in.

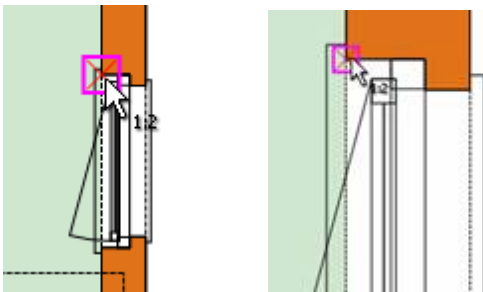

### Snapping directions

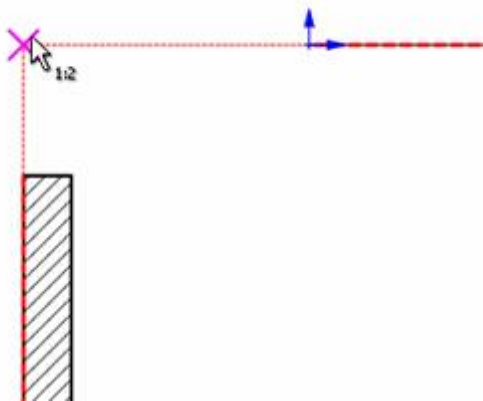

The snap function for directions allows you to snap parallel or perpendicular to directions of already drawn elements during input.

Depending on the setting in the **Snap points** dialog, wall axes, inner and outer wall sides and lines are used for snapping directions. In addition, the horizontal and vertical directions and the directions of the angle grid are suggested by the input point.

The dialog is opened with **Options|Snap...** in **Construction** mode.

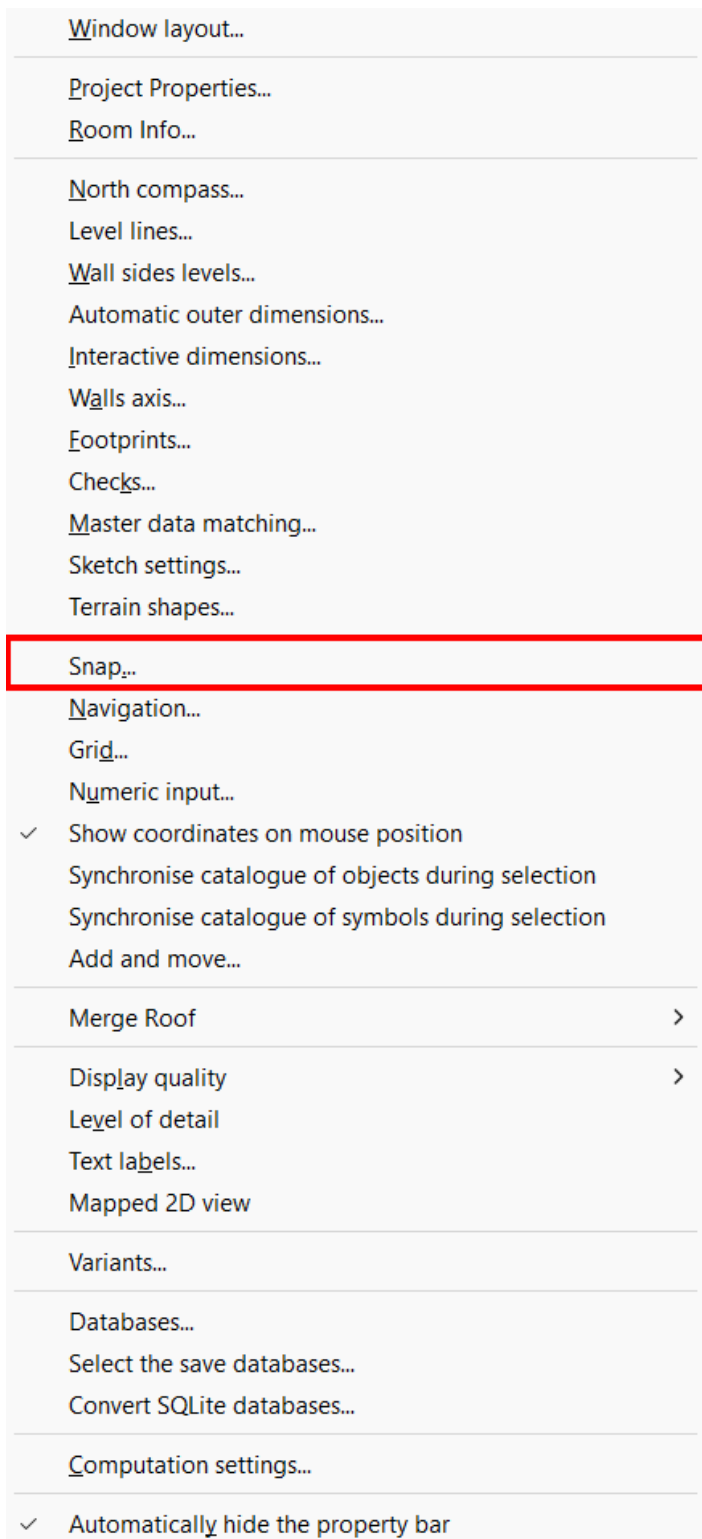

## The dialog

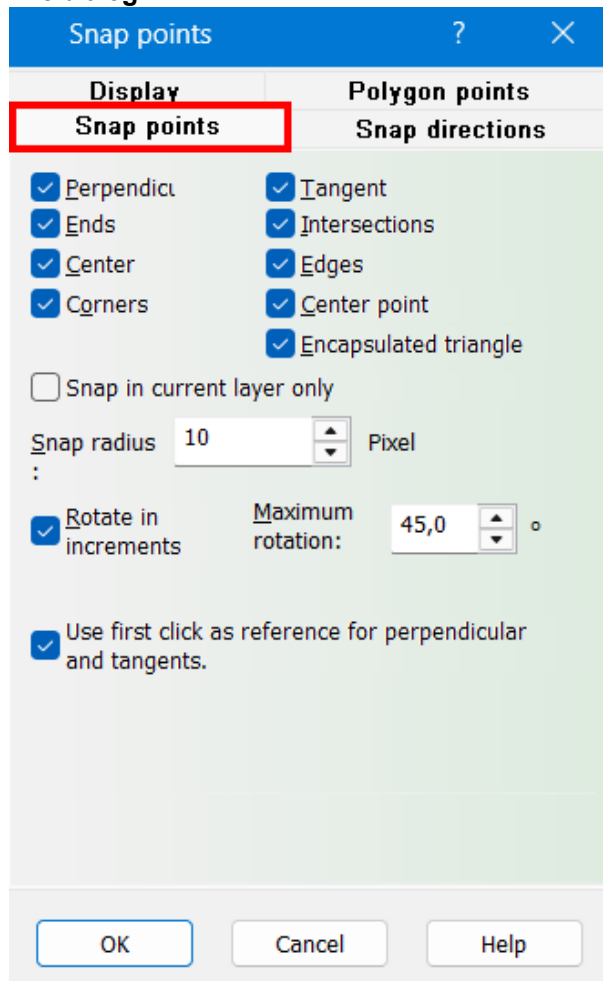

The dialog is opened with Options|Snap... in **Construction** mode.

**Snap to directions:** This general setting determines whether snapping to directions is used.

Optionally, this function can also be activated with the button  *Snap to directions* in the position bar.

**Fixed directions:** Horizontal, vertical and angular grids are suggested as snap directions.

**Variable directions:** Perpendicular and parallel from wall sides, axes and lines are snapped as directions.

**extend from:** Wall sides, axes and lines are extended. Intersections of two extended segments are also snapped.

**Maximum extension:** This value specifies the maximum distance between the reference elements in order to snap to their direction or extension.

#### 5.4.4 Crosshairs

The **Show crosshair** button  can be used to optionally display a crosshair on the drawing area in addition to the arrow display of the cursor.



Only the arrow symbol is displayed outside the drawing area.

The line style of the crosshairs and the visibility of the snap radius can be selected in the **Options|Grid** menu.

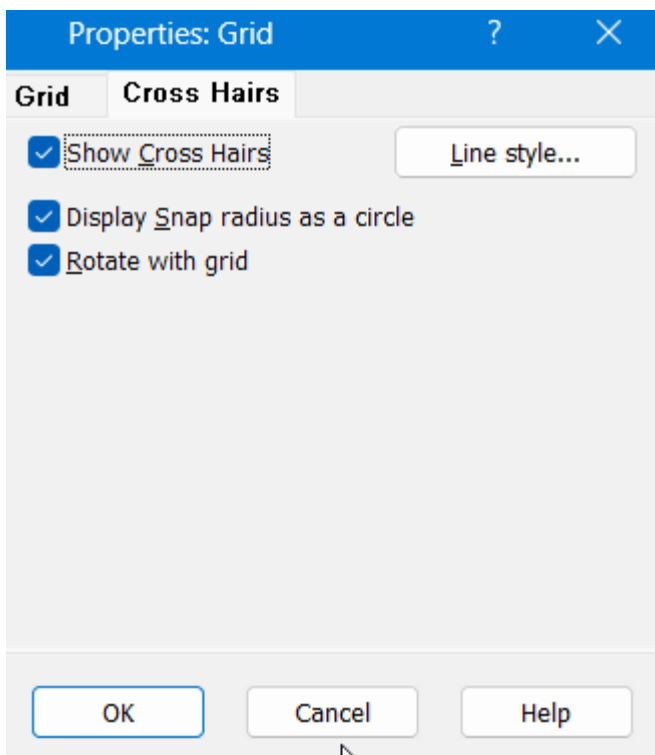

#### 5.4.5 Online dimensions

Check whether the display of the online dimensions is switched on. (Switch  in the position bar). If you select a drawn element in <%SOFTWARE% >, the online dimensions are displayed. The prerequisite for this is that the settings in the dialog **Options|Interactive dimensions...** dialog (described below) are set accordingly.

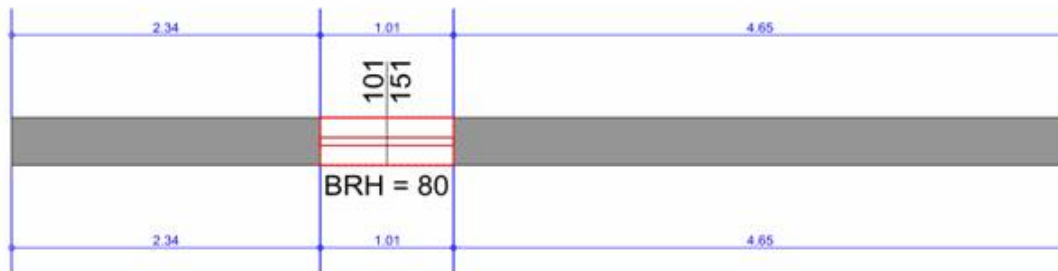
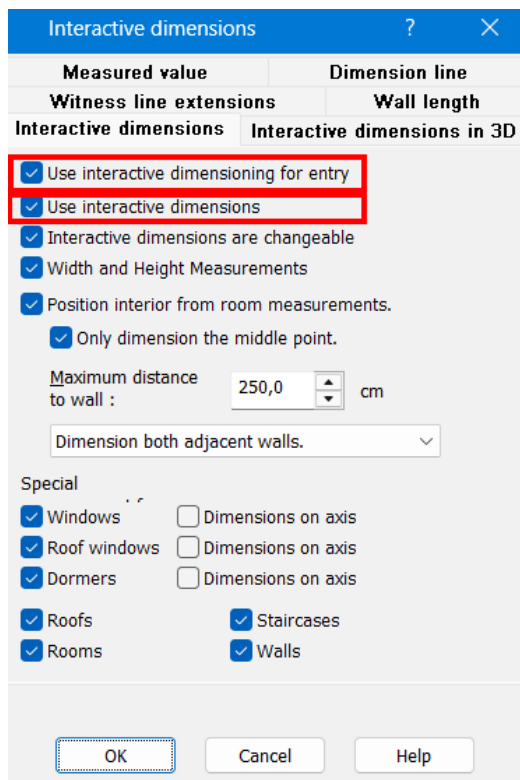

Online dimensions allow the user to edit or position components easily and accurately. Click on the desired dimension and change the value by entering it or by rolling the scroll wheel. The changes are displayed immediately.

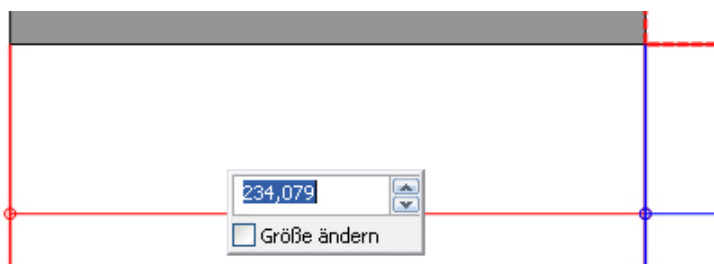

The Change size option is also offered for openings. If it is activated, the size of the opening is changed, but the opposite side of the opening remains unchanged.

For all linear components (walls, beams, etc.), the center point of the element is assumed as the fixed point for the change, but each side can also be fixed during the change using the two fixation buttons.

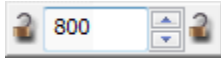

Online dimensions are also active in 3D mode if the settings in the **Options|Interactive dimensions...** dialog have been made accordingly. dialog box have been made accordingly.

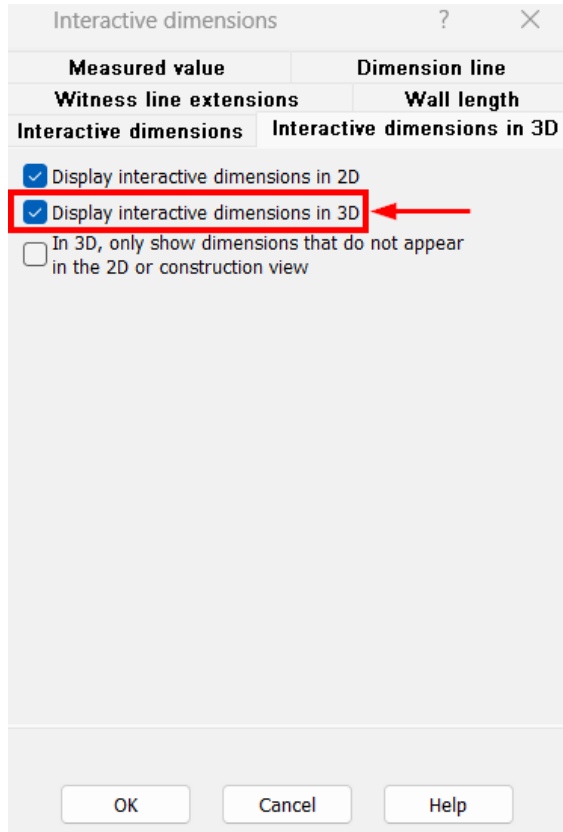

This is particularly useful for positioning windows/doors.

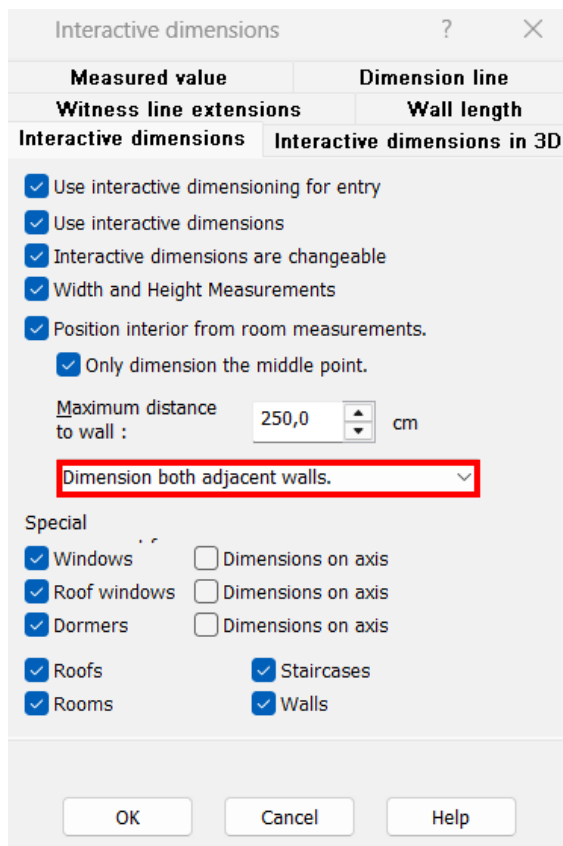

The parameters for the online dimensioning are defined in this dialog.

First, you can select whether or not the online dimensions are shown when entering components. The next values determine whether the dimensions are shown for selected elements and whether they can be changed.

**Measure width and height** applies to all elements, with the exception of the elements with special dimensions listed at the bottom of the dialog.

For many elements, the distance within rooms to the nearest wall(s) can be measured. It is important that the maximum distance to the walls does not exceed the value specified here. Select the walls to which the online dimensions are shown in the selection list.

Information on the dimension number, dimension line and dimension guide can be found in the chapter **Dimensioning**.

See also --> [Online dimension settings](#)<sup>1651</sup>

## 5.4.6 Online dimensions for wall segments

This new editing mode supports you when entering walls, but also when checking the dimensional accuracy.

easyEDIT can be activated for any floor plan using the icon



icon in the grid bar.

An example floor plan with easy EDIT would look something like this. All dimension chains are created automatically as online dimensions.

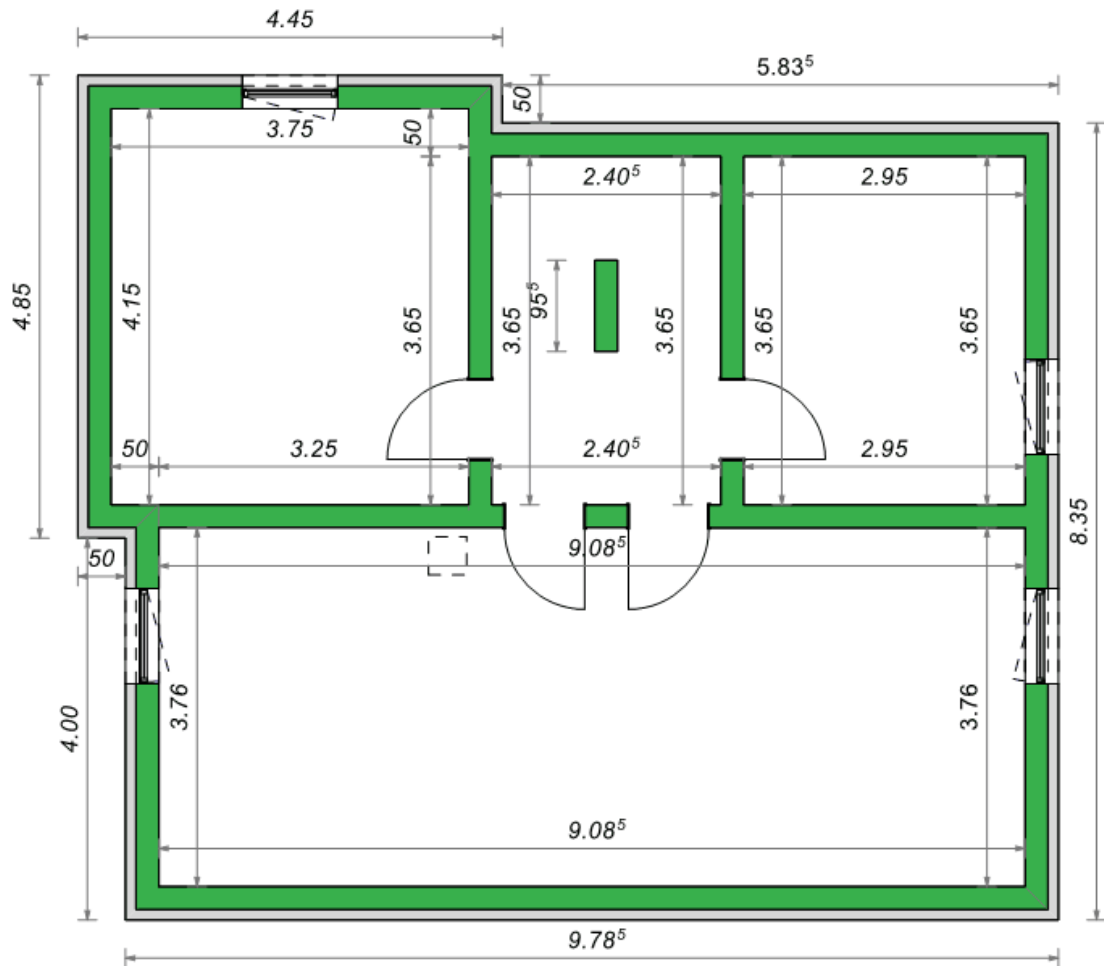

To exit easyEDIT, click on the icon  in the grid bar again.

Change with easyEDIT:

Each online dimension is linked to a wall. If you move the mouse pointer over the dimension, the wall is highlighted.

The online dimension can lengthen or shorten the wall centrally in both directions or only in one of the two directions.

For a centric change, please click on the dimension number of the online dimension, for one of the two directions, click on the dimension arrow in the desired direction.

The dialog for entering dimensions opens:

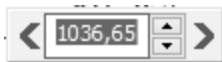

The dimension changes the left and right wall ends

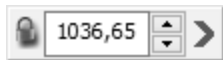

Only the right wall end is moved. Moving only the left wall end works in the same way.

### 5.4.7 Shortcut keys

	Shift	Ctrl	Character	
			<b>A</b>	Ripping
			<b>B</b>	Set operating point
			<b>C</b>	Copying (Copy)
			<b>D</b>	Rotate
			<b>E</b>	Change wall side at the end of the wall (see also <b>Q</b> )
			<b>F</b>	Finishelement
			<b>G</b>	Extend
			<b>I</b>	Mirror I
			<b>L</b>	L-cut
			<b>M</b>	Move(Move)
Press multiple times = change the input type			<b>N</b>	Definition of the numerical input type
			<b>O</b>	Set zero point
			<b>P</b>	
			<b>Q</b>	Change wall side at the start of the wall (see also <b>E</b> )
			<b>R</b>	Determine <b>working</b> direction
			<b>S</b>	Stretch
			<b>T</b>	T-section
			<b>U</b>	Undo ( <b>toggle U</b> = redo)
			<b>V</b>	Determine offset
			<b>W</b>	Change reference point (toggle)
Press multiple times -> Change symbols/objects/material			<b>X</b>	Explorer (open catalog)
			<b>Y</b>	Change layer (with <b>Shift y</b> - up/down)
			<b>Z</b>	Zoom (window)
			<b>Spacebar</b>	
			<b>&lt;</b>	Change storey (with Shift> up/down)

			<b>0</b>	Zoom / Show all
In the numeric keypad			<b>1-9</b>	Pan
			<b>F1</b>	Help current process
			<b>F3</b>	Do not catch next point
			<b>F4</b>	
			<b>F5</b>	
			<b>F6</b>	Only active projectile visible
			<b>F7</b>	All projectiles visible
			<b>F8</b>	Active and selected projectiles visible
			<b>Toggle</b>	Deactivate angle grid
			<b>Strg</b>	Do not snap now
			<b>Backspace &lt;-</b>	Undo last action, for polygon (and wall?) last point
			<b>Pos 1</b>	Zoom to object
			<b>End</b>	Show last section
	<b>Toggle</b>	<b>Strg</b>		
	<b>X</b>		<b>A</b>	
	<b>X</b>		<b>B</b>	Text (labeling)
	<b>X</b>		<b>C</b>	
	<b>X</b>		<b>D</b>	
	<b>X</b>		<b>E</b>	
	<b>X</b>		<b>F</b>	Window
	<b>X</b>		<b>K</b>	Circle
	<b>X</b>		<b>L</b>	Line
	<b>X</b>		<b>M</b>	Dimensions
	<b>X</b>		<b>P</b>	Polygon
	<b>X</b>		<b>Q</b>	
	<b>X</b>		<b>R</b>	Arc (radius)
	<b>X</b>		<b>S</b>	
	<b>X</b>		<b>T</b>	Door
	<b>X</b>		<b>U</b>	Redo (without <b>shift</b> = undo)
	<b>X</b>		<b>V</b>	Reverse offset on/off
	<b>X</b>		<b>W</b>	Wall
	<b>X</b>		<b>X</b>	
	<b>X</b>		<b>Y</b>	Layer change (with <b>Y</b> - up/down)
	<b>X</b>		<b>Z</b>	
	<b>X</b>		<b>Spacebar</b>	
	<b>X</b>		<b>&gt;</b>	Change floor (with <b>&lt;</b> up/down)
	<b>X</b>		<b>0</b>	
	<b>X</b>		<b>1-9</b>	
	<b>X</b>		<b>F1</b>	Help for the object pointed to with the mouse

	<b>X</b>		<b>F4</b>	
	<b>Umsch alt</b>	<b>Strg</b>		Exit application and save query project
		<b>X</b>	<b>A</b>	Select all
		<b>X</b>	<b>B</b>	Export image file
		<b>X</b>	<b>C</b>	Copy selected and to clipboard
		<b>X</b>	<b>D</b>	Rotate element by 45° around z-axis
		<b>X</b>	<b>E</b>	
		<b>X</b>	<b>F</b>	Switch to the next snap point
		<b>X</b>	<b>G</b>	Group
	<b>X</b>	<b>X</b>	<b>G</b>	Cancel grouping
		<b>X</b>	<b>H</b>	Selection in the background
		<b>X</b>	<b>I</b>	Import image file
		<b>X</b>	<b>N</b>	New project
		<b>X</b>	<b>O</b>	Open existing project
		<b>X</b>	<b>P</b>	Print project
		<b>X</b>	<b>Q</b>	
		<b>X</b>	<b>R</b>	Selection in the foreground
		<b>X</b>	<b>S</b>	Save
		<b>X</b>	<b>T</b>	Duplicate selection offset
		<b>X</b>	<b>U</b>	Save under a new name
		<b>X</b>	<b>V</b>	Paste contents of clipboard
		<b>X</b>	<b>W</b>	
		<b>X</b>	<b>X</b>	Remove selection and cut to clipboard / cut
		<b>X</b>	<b>Y</b>	
		<b>X</b>	<b>Z</b>	Undo
		<b>X</b>	<b>1</b>	Do not catch
		<b>X</b>	<b>2</b>	Snap to all points
		<b>X</b>	<b>3</b>	Snap to grid
		<b>X</b>	<b>4</b>	Snap to end points
		<b>X</b>	<b>5</b>	Snap to center points
		<b>X</b>	<b>6</b>	Snap to corners (for polygons)
		<b>X</b>	<b>7</b>	Snap to intersection points
		<b>X</b>	<b>8</b>	Snap to edges
		<b>X</b>	<b>9</b>	Rotate (snap) when moving
		<b>X</b>	<b>F4</b>	Close current project

## 6 Display

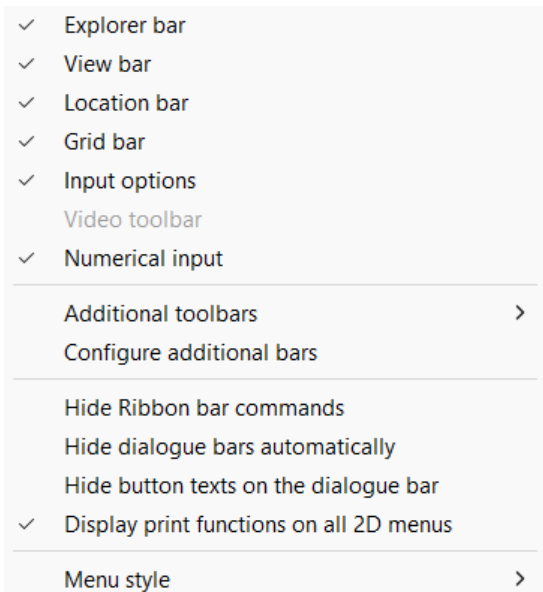

The visibility of the individual toolbars and input bars can be defined in this menu. In addition, the main menu bar of the ribbon can be hidden (Hide menu bar)

The Print functions on all 2D menus function shows the most important print functions in all 2D ribbons. Changes only become visible after a restart.

Different colors can be selected for the interface in the Menu style submenu.

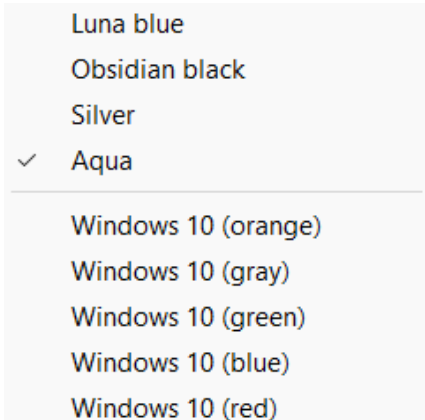

## 7 Freely configurable toolbars

All toolbars of the extended ribbons for 2D elements, editing (divided into 2 toolbars), trimming, dimensioning and evaluations are available as additional toolbars.

Just like the commands in the ribbon, only the commands that can actually be used are offered for each mode.

The selection and configuration can also be made by right-clicking on a toolbar.

### Visibility of the toolbars

In the Additional toolbars menu item, you can select which of the additional toolbars are visible.

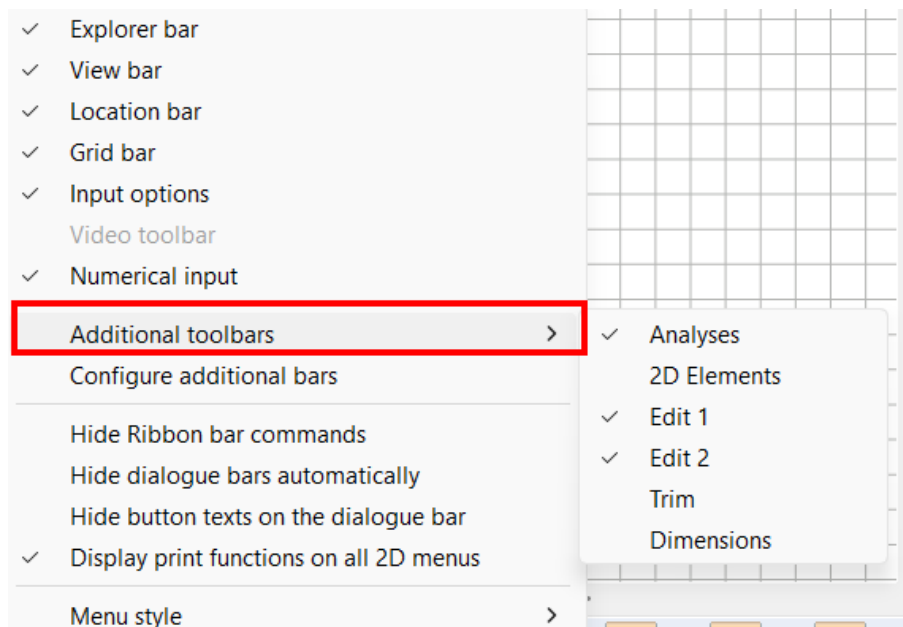

### Configuration of the toolbars

The "Configure additional toolbars" menu item takes you to the Toolbars dialog. Here you can define which toolbar commands are visible.

- ✓ Explorer bar
  - ✓ View bar
  - ✓ Location bar
  - ✓ Grid bar
  - ✓ Input options
  - Video toolbar
  - ✓ Numerical input
- 
- Additional toolbars >
- Configure additional bars**
- Hide Ribbon bar commands
- Hide dialogue bars automatically
- Hide button texts on the dialogue bar
- ✓ Display print functions on all 2D menus
- 
- Menu style >

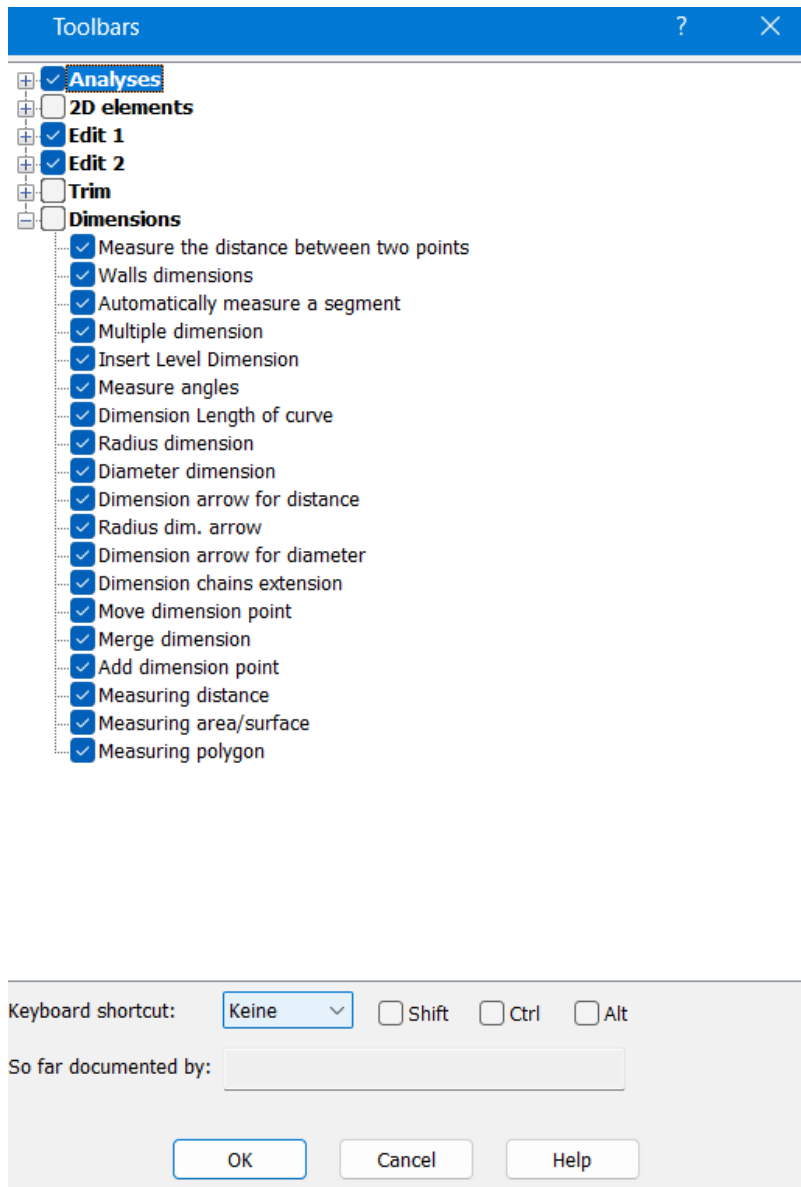

### Shortcut keys

A keyboard shortcut can also be defined for all toolbar commands. Only key combinations that have not yet been defined by the software itself should be used.

## 8 Window layout

## 9 Toolbar grid

Various design aids are available in the **grid bar**, which can simplify the input of components.

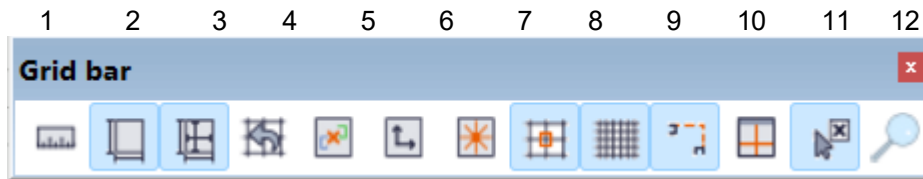

**Button 1** "Ruler on/off"

**Button 2** can be used to switch on/off the online dimensions.

**Button 3** activates the online dimensions for wall segments (EasyEdit)  
[Online dimensions for wall segments](#)<sup>[183]</sup>

If **button 4** is activated, the grid direction can be rotated by clicking on a line, for example:

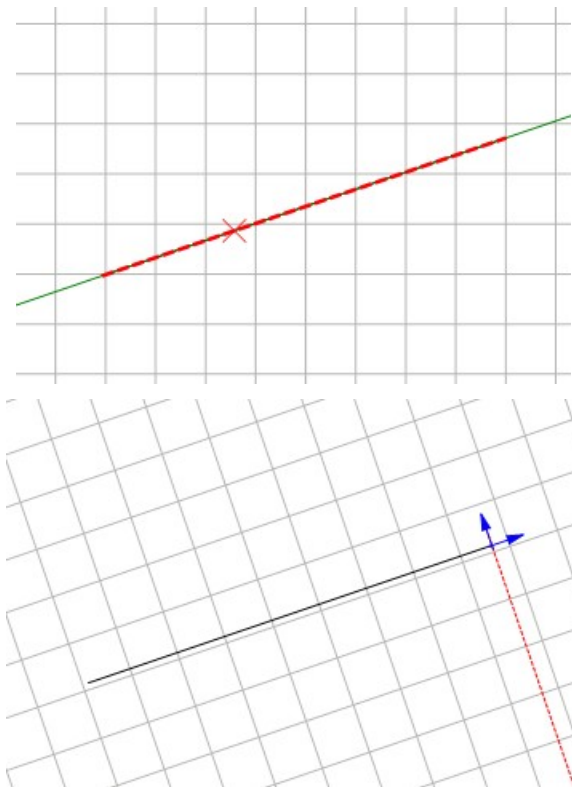

**Button 5** can be used to set a [working point](#)<sup>[98]</sup>.

**Button 6** can be used to change the [zero point](#)<sup>[98]</sup>.

The **angle grid** is activated/deactivated via **button 7**.  
 The properties for this are called up by clicking on the icon with the right mouse button

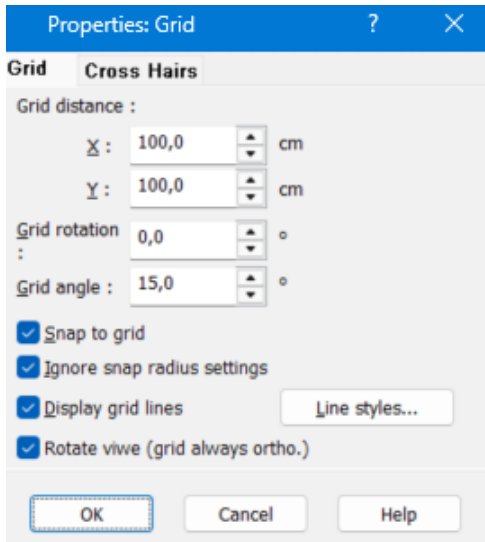

If the angle **grid** is switched on, it is only possible to work in the angle steps that are switched on.

**Button 8** activates '**Snap to grid**'.

Attention: even if the grid is switched off, the grid snap remains activated if it is switched on. This means, for example, that it may not be possible to snap to a specific point that lies within the grid.

**Button 9** activates and deactivates the grid points/visibility of the grid

**Button10** '**Snap to directions**' see also [Snapping](#)<sup>[176]</sup>

**Button11** activates/deactivates the crosshairs

12. display coordinates on the mouse pointer



This coordinate tracker ([numerical input](#)<sup>[227]</sup>) makes it possible to enter a component quickly and accurately. This display on the mouse is activated via **button 11** in the grid bar and initially refers to the zero point and, when entering, to the last point clicked on with the left mouse button.

## 9.1 Grid

The drawing grid can be switched on and off alternately using the button  Grid **on/off** (or via the menu bar **View|Grid**). The grid properties are selected via the **Options|Grid...** menu item.

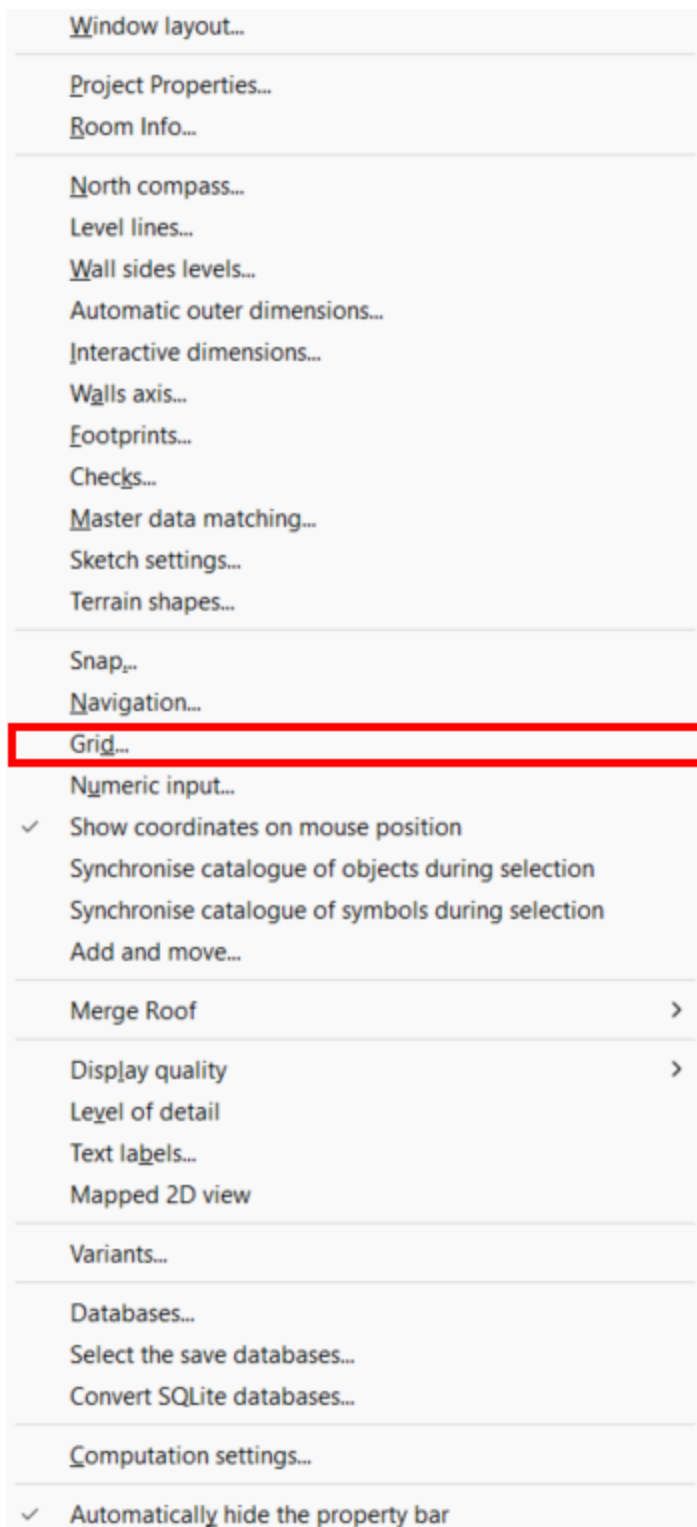

It is displayed as an infinitely large, orthogonal grid consisting of points or lines in the X and Y directions.

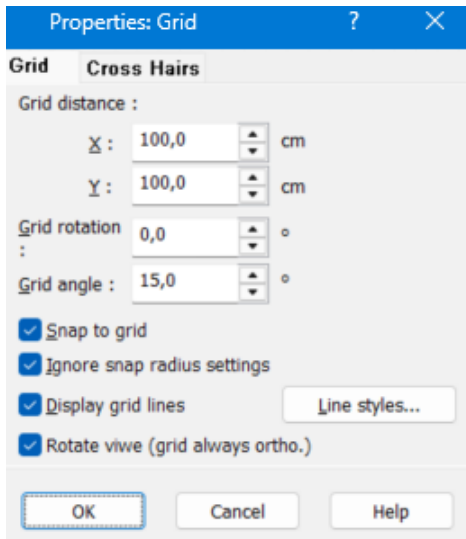

**Grid spacing:** Select the spacing of the grid line separately for the X and Y directions

**Rotation:** Rotation angle of the grid, measured counter clockwise. When the grid is rotated, the coordinate system rotates, i.e. the zero direction is rotated.

**The rotation of the grid can also be adapted to drawn elements:** To do this, click on the button  in a 2D mode and then select the correspondingly rotated element. The grid and the coordinate system are rotated.

**Angle grid:** The angle grid helps with the construction of orthogonal elements. If the angle grid is set to 45°, all entries (e.g. a new line) are projected to 45° or a multiple of this (90°, 135°, ...), regardless of whether the end point was snapped exactly or not.

The angle grid is activated with the button  **Angle grid**.

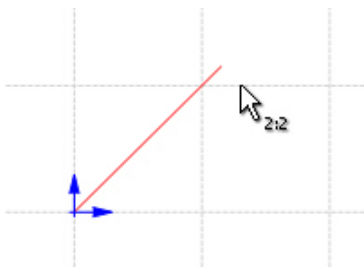

**Snap to grid:** Is activated with the  button in the position bar. You can now snap to grid points. The option **Ignore the set snap radius** means that the next grid point is always snapped to, regardless of whether it is within the search radius of the snap option or not.

**Display grid lines:** The grid can be displayed with dots or lines. If the **Show lines** option is selected, the line type of the grid lines can also be selected.

# 10 Toolbar view

## 10.1 in a 2D mode

In the toolbar **view**, you can make general settings and control the visibility in the planning.



19 and the advanced options:

- Transform in 2D view...
  - Mapped 2D view >
  - Paper fill >

---

- Display quality (2D) >
- Display (3D) >
- Ignore transparency
- Display openings

---

- 2D display for 3D objects
- Show staircases through openings
- Show roof in all storeys
- Show profiled beams in all storeys
- Show chimneys in all storeys
- Display protected elements in grey
- Transfer room fills from apartments
- Transfer room fills from lighting areas
- Transfer room fills for fire compartments
- Transfer room fills from flooring

---

- Sketch >
- Walls axis
- Footprint
- Elevation points of variable thickness platform/slab/panel
- Checks >
- Cameras
- Light sources
- Hide >

---

- Level lines

### 10.1.1 Review assistant

Non-orthogonal walls are marked. Selection in the pull-down menu under **View|Checks|Cascade Footprints** - under **Options|Checks** or **View|Checks|Sloped walls|Options...** the tolerances etc. can be set.

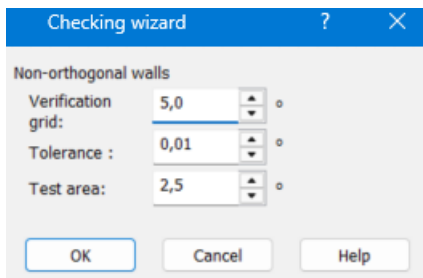
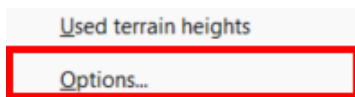
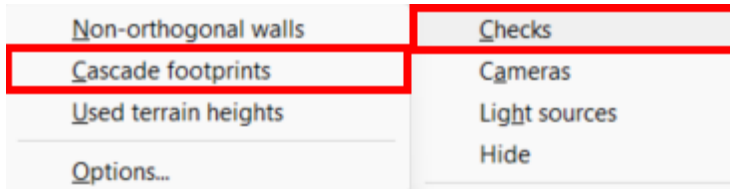

### 10.1.2 Sketch settings

floor plans and 2d views can be displayed as a sketch (menu item **View|Sketch|Display as sketch**) . all edges of the drawing are blurred according to the **sketch settings**, giving the impression of a freehand drawing. the selection is made via the menu item **Project|Sketch settings...**

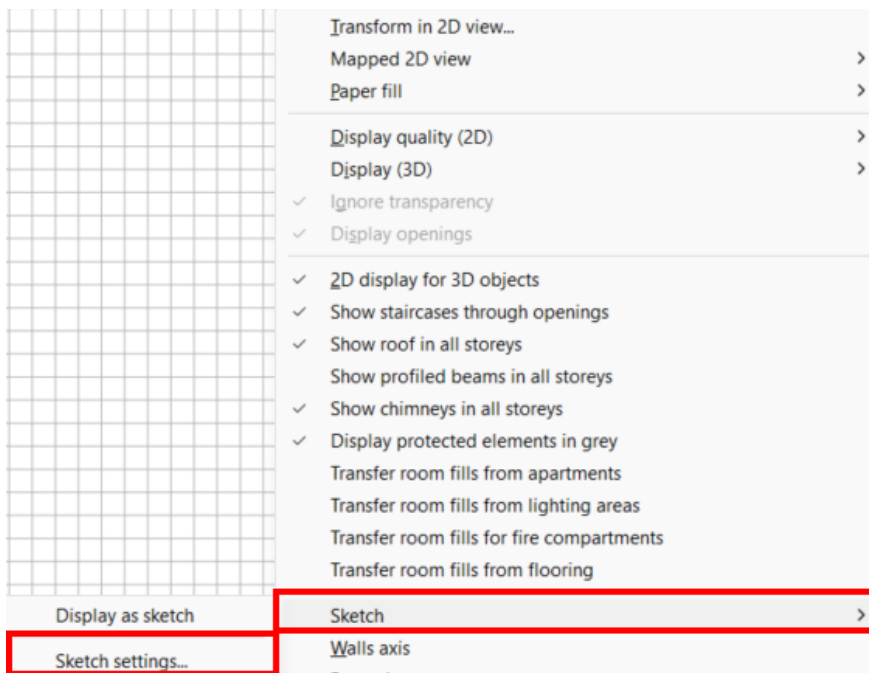

dimension lines, arcs and circles are currently not blurred.  
 please note that texts are not displayed differently.  
 use a freehand font if necessary.

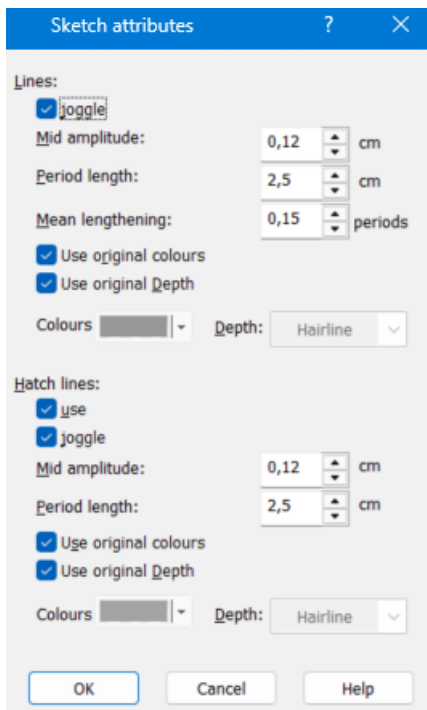

**sketch settings:**

the following sketch parameters can be influenced separately for lines and hatching:

**use**

only applies to hatching. deactivate this option to hide hatching in the sketch display.

**blur**

lines or hatchings are displayed blurred.

**average amplitude**

how much the blurred line deviates from the straight line.

the values are entered in cm on the printout, so the result depends on the scale.



small amplitude (0.5 cm) large amplitude (1.0 cm)

**period length**

small period length (1.0 cm) large period length (3.0 cm)

**average extension**

the freehand lines are extended at the corners. to give a realistic impression, this extension varies according to a random generator.

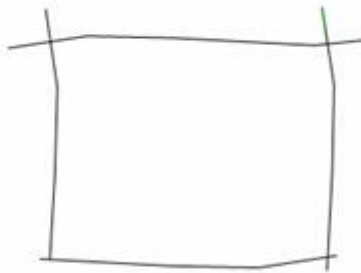

a rectangle of four lines. the end points lie exactly on top of each other. the extension is generated by the sketch display.

**color and line thickness**

optionally, all lines can be shown in a selected color and thickness for the sketch display.

**note:** the usual architectural representation of "overdrawn corners" with otherwise straight lines is achieved by setting the value for the amplitude to **0** and therefore only the corresponding value for the **middle extension** is relevant.

## 10.2 Excerpts

The current screen section can be saved in 2D and 3D mode and called up again at any time.

Only the scale, the section, the layer and storey visibility of the display are saved or restored, but not the content of the planning.

Save the current section in the **View|Section|New** menu



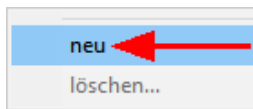

Enter a name and select which parameters are to be saved in the section.

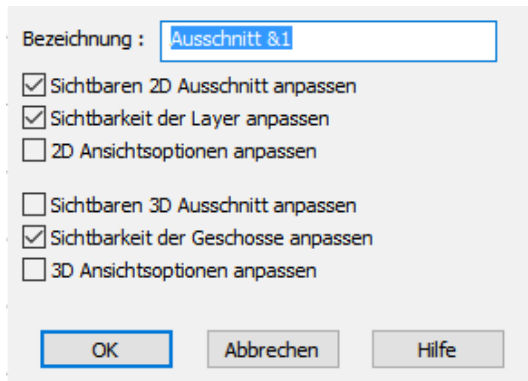

**For 2-dimensional views**

Adjust visible 2D section: the section and the scale of the view are saved  
 Adjust layer visibility: the current visibility of the layers is saved in the section  
 Customize 2D view options: Options such as grid, external dimensioning, etc. are saved.

**For 3D mode**

Customize visible 3D section: the viewer position is saved.  
 Adjust visibility of storeys: the current visibility of the storeys is saved in the section  
 Customize 3D view options: Options such as display quality, time, etc. are saved

You can restore a saved section with **View|Section|Section name**.  
 You can delete a saved section with the command **View|Section|Delete section**.  
 A list of the sections saved in the project appears. Select the relevant section and click on the **Delete** button in the form.  
 The functions **Last section** and **Next section** are also available in the **View** menu. These functions can be used to quickly and repeatedly change the image section between two saved sections.

Sections that only contain the visibility of layers can also be selected or saved in layer management. The same applies to storeys.

**10.3 in a 3D mode**

The view bar has other functions in 3D mode:



Backed **2D view** see: *Backed 2D view*  
**Paper fill** affects the setting color of the background  
**Display quality** controls the speed of the project, with a low display and substitute fills, work can be carried out more quickly on larger projects

*Level of detail* see: [Level of detail](#)<sub>2161</sub>

## 11 Ribbon project

The project-related properties can be defined under **Project**. These are also stored in **standard.cad**.

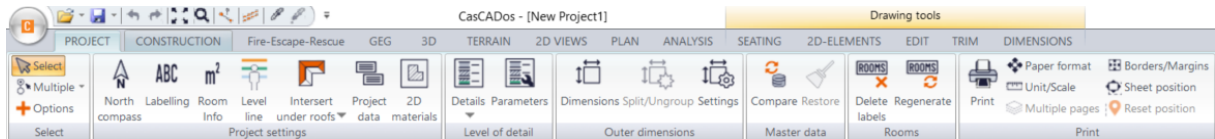

### 11.1 North direction

The north arrow can be seen in both construction and 3D mode. The size and rotation of the north arrow can be specified in the properties of the *north direction* in the menu **Project|North direction. ...** menu.

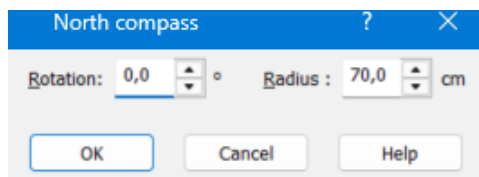
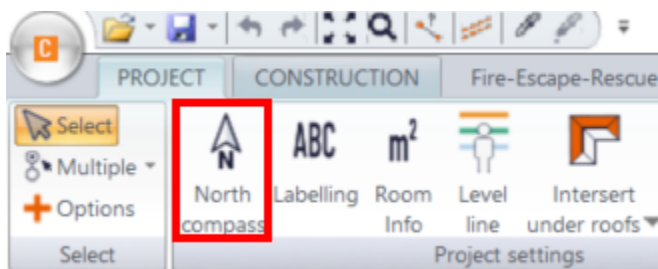

The north arrow is not only used to specify the north direction. It also has an effect on the time-dependent view, as the incidence of sunlight can be calculated based on the definition of the north direction. The north arrow is therefore used to determine the exact position of the sun.

The north arrow can be moved in construction mode by clicking on it with the mouse and then dragging and dropping it while holding down the mouse button. If you double-click the north arrow, you can rotate the north arrow, i.e. change its direction.

Visibility of the north arrow:

The visibility of the north arrow can be selected via the view bar.



## 11.2 Labeling

Labels can be shown for the following components in the planning:

- **Rooms:** the room stamp, the settings can be found in the **Rooms** tab.
- **Windows, doors and openings:** the axis dimensions with width and height, the sill and lintel height as text for the opening.
- **Stairs:** Number of rises as well as rise height and tread of the stairs as text
- **Groups:** Labeling of the group designation and the description text
- **Terrain heights:** Show terrain heights in the planning, highlight positive heights
- **Skylights:** Display skylight labeling in planning, define prefix
- **It is important** for all properties in this dialog that these values are used as the default setting for all elements in the planning that have the **Default** attribute set for the label. However, an individual label style can be entered for each individual element.

### 11.2.1 General

The selection is made in the pull-down menu via **Options|Text Labels...**,

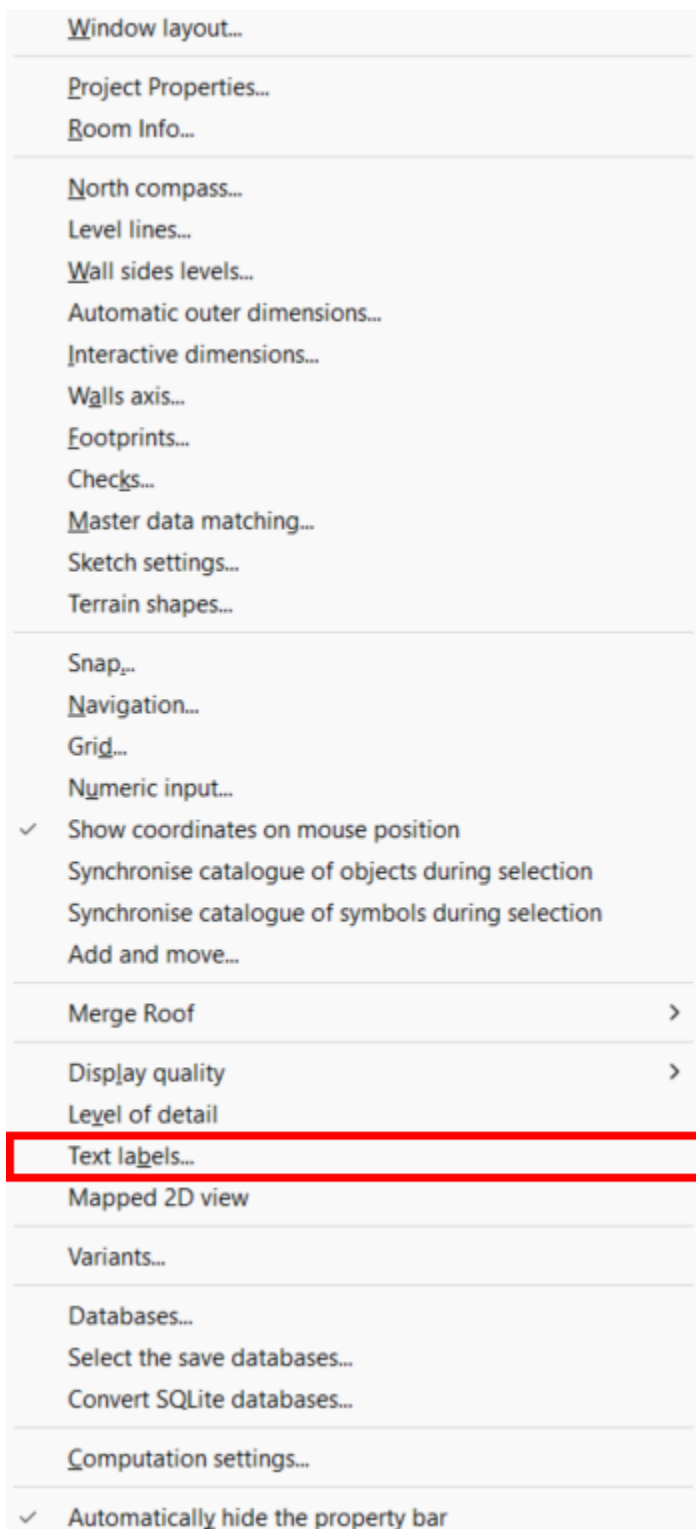

**General** tab :

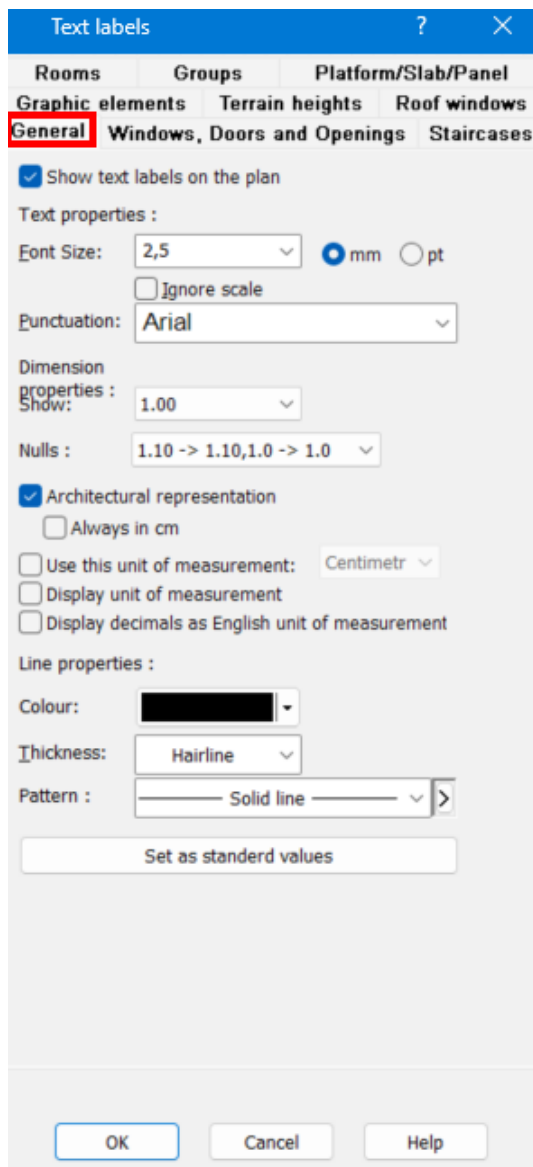

The standard font can always be referred to in all labeling dialogs. The settings for this standard font, its rounding and display parameters etc. are set in this tab. The advantage of managing as many texts as possible as standard fonts is that they can be changed quickly and easily, for example after changing the scale. It is recommended that the font most frequently used within the office is set as the default font.

Optionally, you can specify in this dialog whether all labels are shown or not; this corresponds to the **View|Labels** menu.

## 11.2.2 Rooms

The selection is made via **Options|Text Labels, Rooms** tab

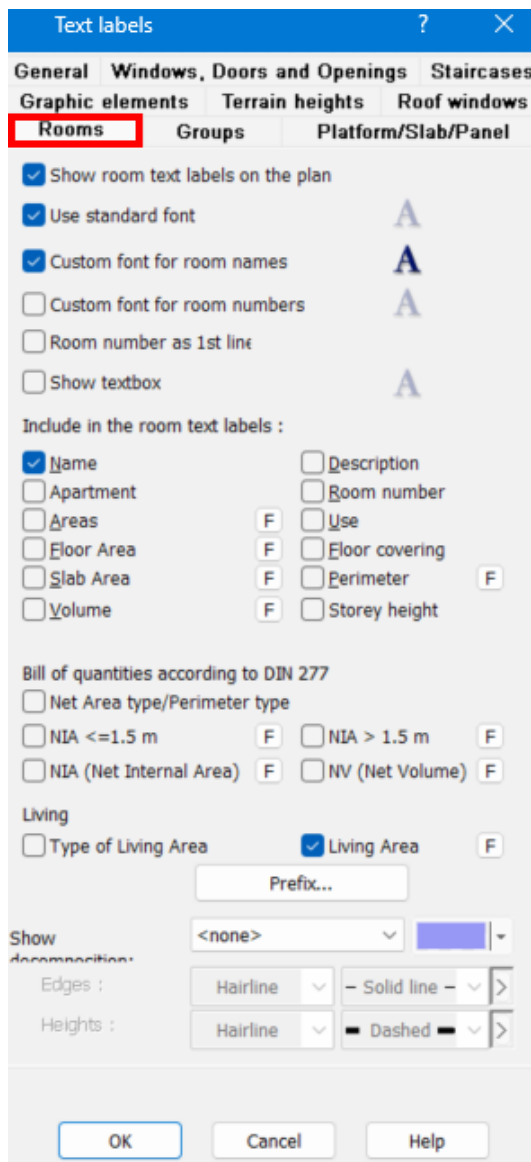

Select whether or not room labels are shown in the planning.

Select **Use default font** to use the font defined in the **General** tab for the room stamp. If you deactivate this option, the font can be defined by clicking on the **A** button.

In contrast to the function described above, the room name can be given its own font style. The text frame is drawn around the room stamp; the properties for *outline*, *fill* and possibly *hatching* can be set. The size of the text frame adapts dynamically to the size of the room stamp. Use the corresponding radio buttons to select the contents of the room stamp; an explanatory description can be entered for each line under **Prefixes**.

The **F** button also displays the formula of the calculation approach for the corresponding area. The calculation approach can also be displayed graphically as an area breakdown in the planning. To do this, select the option

**Show area decomposition:** The area decomposition for which the **F** switch is activated is always displayed.

### 11.2.3 Windows/Doors/Wall recesses/Roof windows

The selection is made via **Options|Text Labels**, tab **Windows, doors and openings**

The screenshot shows the 'Text labels' dialog box with the following settings:

- Show text labels on the plan:**
- Heights are shown:** From floor
- Prefix for the Sill Level:** BRH (Abb. 'SL =')
- Prefix for the Lintel Level:** STUK (Abb. 'LL =')
- Do not show the sill level as 0.0:**
- Sill top level instead of the bottom level of the frame:**
- Dimension type:** Outer dimensions
- Settings for:** Sill Level
  - for doors:  Show,  Interior
  - for windows:  Show,  Interior
  - for wall openings:  Show,  Interior
- Use standard font:**

Buttons at the bottom: OK, Cancel, Help, and a 'Set with standard values!' button.

Use the first option to select whether labels for windows, doors and openings are shown or not. If the **Show labels** option is deactivated in the **General** tab, labels are never displayed.

The heights of the parapet and lintel can refer to the following heights:

- **From screed:** the height refers to the top edge of the floor of this storey.
- **From ceiling:** the heights refer to the upper edge of the bare ceiling of the floor below. (Please note that the ceiling below a storey belongs to the storey below).
- **Absolute:** the height refers to the absolute zero value of the planning.

Texts for parapet heights that are exactly at height 0.00 can either be displayed or not. The visibility can be selected separately for windows, doors and openings for the lettering of the parapet, the bottom edge of the lintel and the axis dimensions. In addition, the standard font (defined in the **General** tab) or an individual font can be selected as the font.

#### 11.2.4 Stairs

The selection is made via **Options|Text Labels, Staircases** tab

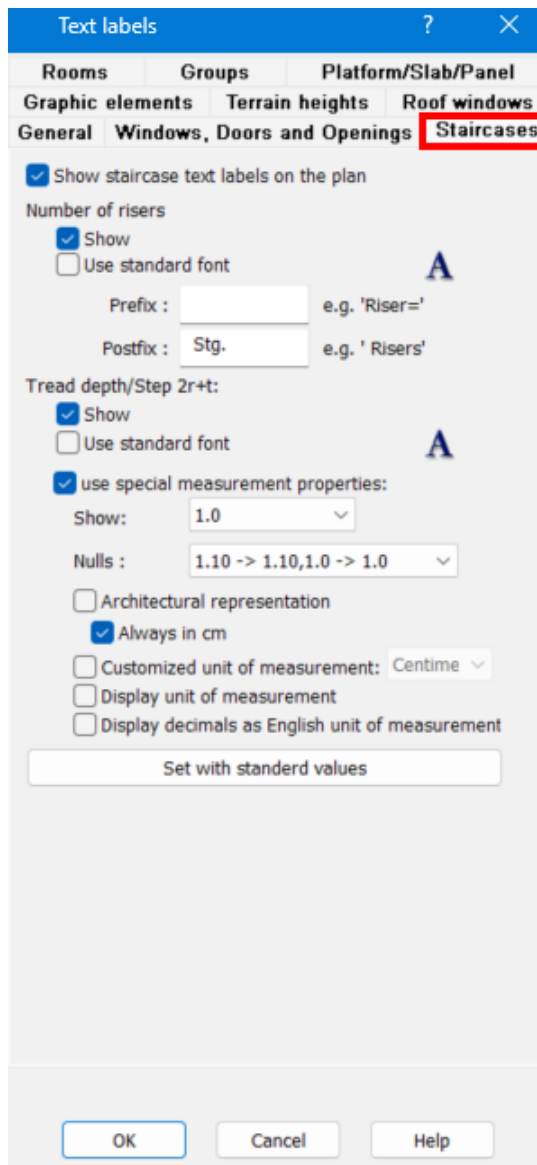

The screenshot shows the 'Text labels' dialog box with the 'Staircases' tab selected. The dialog is organized into several sections:

- General** (selected):
  - Show staircase text labels on the plan
  - Number of risers**
    - Show
    - Use standard font
    - Prefix :  e.g. 'Riser='
    - Postfix :  e.g. 'Risers'
  - Tread depth/Step 2r+t:**
    - Show
    - Use standard font
    - use special measurement properties:
      - Show:
      - Nulls :
    - Architectural representation
    - Always in cm
    - Customized unit of measurement:
    - Display unit of measurement
    - Display decimals as English unit of measurement
- 

- Buttons:** OK, Cancel, Help

Use the corresponding option to select whether stair labels are visible or not. The number of rises and the values for rise/tread width are specified for each stair. Select the **Standard** font or an individual font. You can also use special dimensional properties or select a representation suitable for architects.

## 11.2.5 Groups

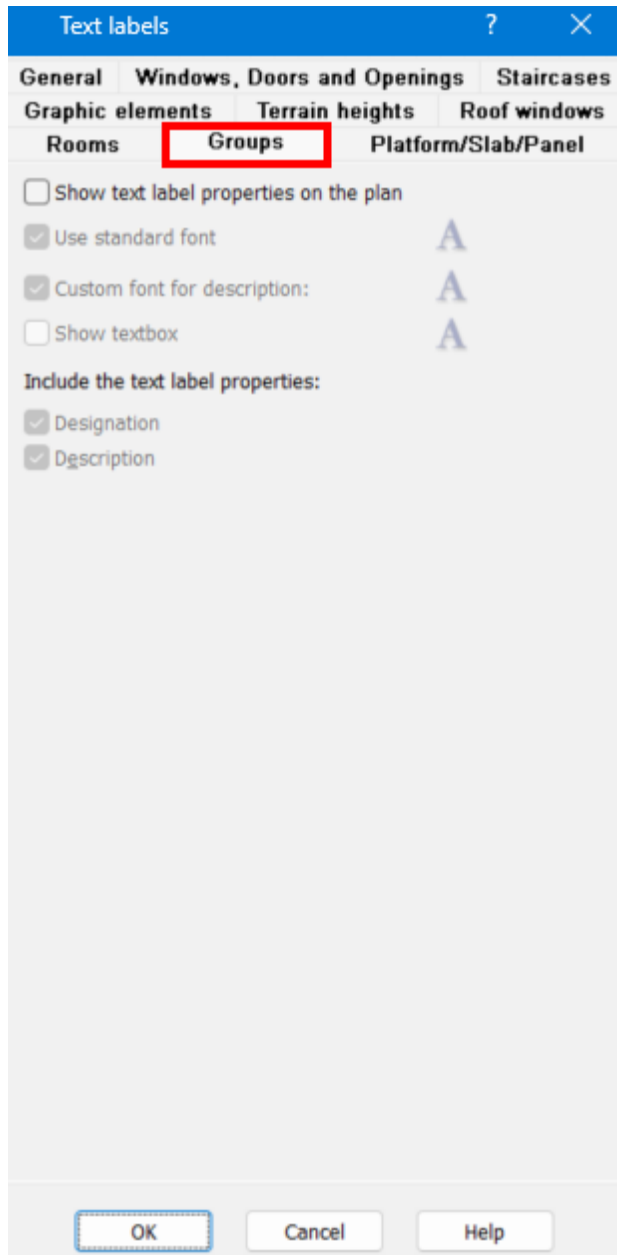

1. global option for the visibility of group labels
2. option to use the default font or an individual setting
3. individual font setting for the label
4. display of the frame around the label
5. the label can optionally display the label and/or the description.  
can be displayed in the label.

All options in this dialog are global properties for the project. Each group can receive individual adjustments that deviate from these specifications (Label properties dialog).

## 11.2.6 Terrain heights

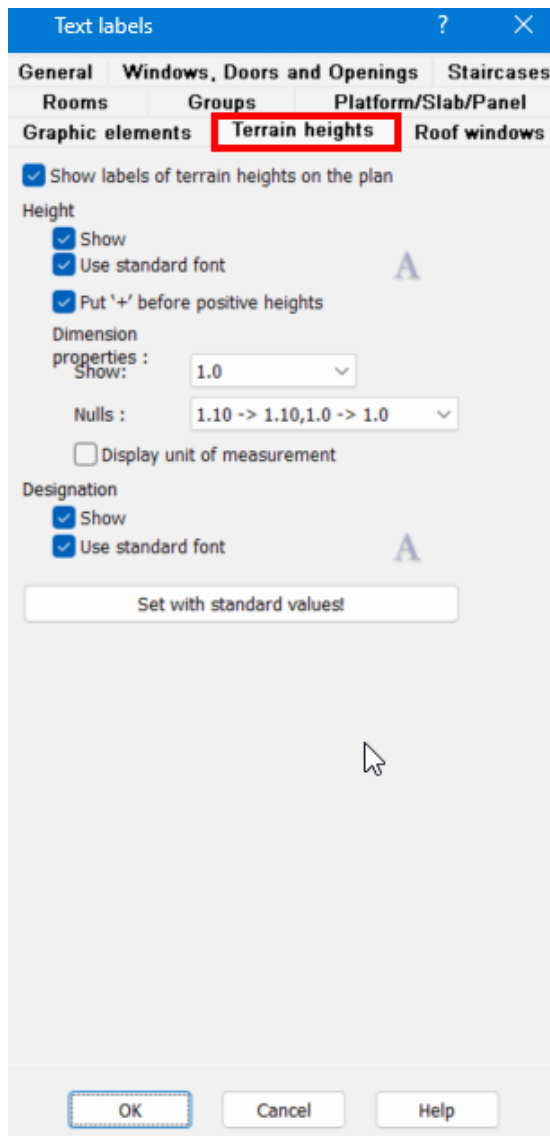

### Selection options:

- Show terrain height labels in planning
- Use the default font/a user-defined font
- Prefix positive heights with a "+" sign
- Define dimension properties
- Show unit of measurement
- Show designation
- Use standard font
- Set to default values!

## 11.2.7 Roof windows

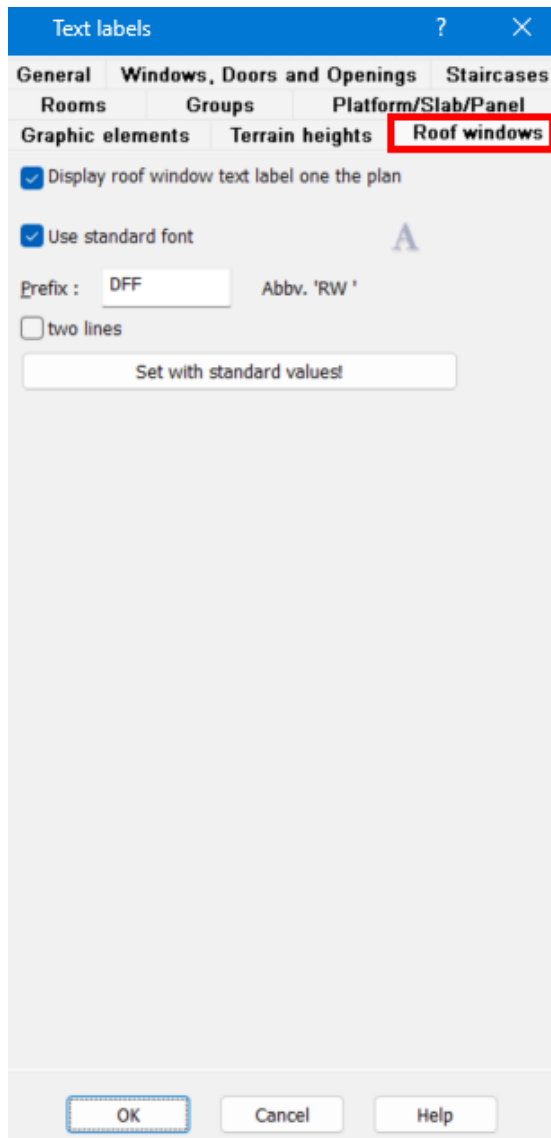

### Selection options:

- Show roof window labeling in planning
- Use standard font/user-defined font
- Assign prefix
- two lines
- Set to default values!

## 11.3 Room info

This dialog is selected via **Project|Room info** in the menu bar:

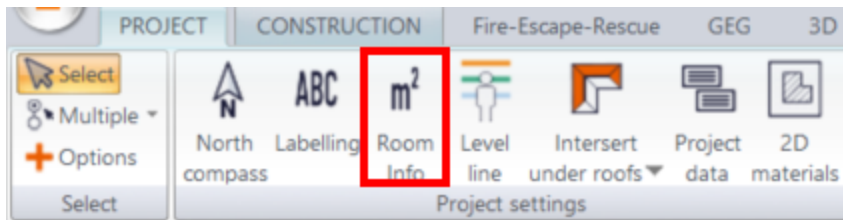

### Room info/DIN277/WoFIVdialog

A screenshot of a dialog box titled 'Room info/DIN 277/Living areas'. It has a blue header bar with a question mark and a close button. The dialog is divided into two tabs: 'Room info/DIN 277/Living areas' (selected) and 'Rounding'. Under the selected tab, there are several sections with checkboxes and input fields:

- Loft areas deduction:**
  - Bottom level line
    - Height: 100,0 cm
    - Area deduction: 100 %
  - Top level line
    - Height: 200,0 cm
    - Area deduction: 50 %
  - Use structural dimensions
    - Deduct standard rate of 3%
  - Remove chimneys
    - Minimal Area: 0,0 cm<sup>2</sup>
    - Area Deduction: 100 %
  - Columns/Posts/Pillars deduction
    - Minimal Area: 0,0 cm<sup>2</sup>
    - Area Deduction: 100 %
  - Allow for doors
  - Add windows and openings
    - If Area is larger than 1000,0 cm<sup>2</sup>
    - If Depth is larger than 13,0 cm
  - Area under staircases: Deduct as in the loft stor (dropdown)
  - Height: 150,0 cm
  - Ignore all slab openings for Apartment Area and NIA

At the bottom, there is a button 'Set with standard values!', and at the very bottom, 'OK', 'Cancel', and 'Help' buttons.

In this dialog, specify how the area calculation of the DIN 277 values and the living space ordinance should be carried out. The standards are defined according to the applicable regulations and standards.

### Rounding dialog

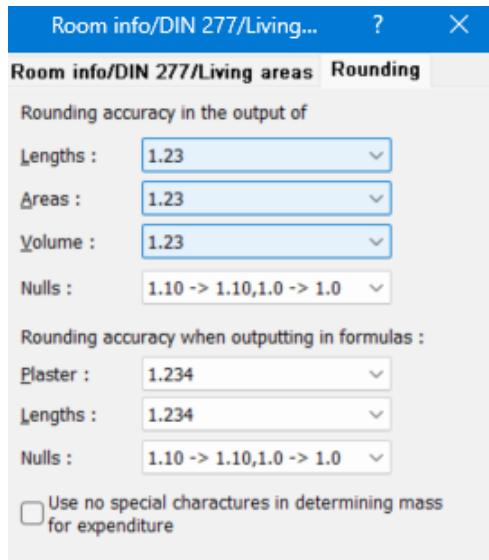

Specify the rounding accuracy for room labels and outputs here.

## 11.4 Contour lines

The position and color of the contour lines are defined in this setting. The selection is made via the menu item **Project** | **Contour lines...**

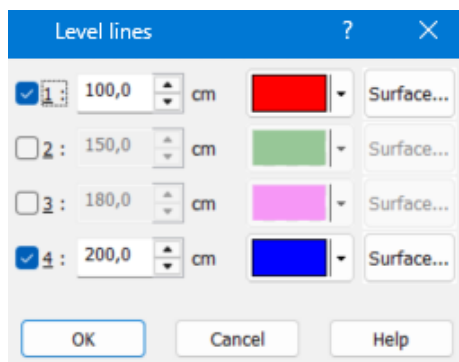
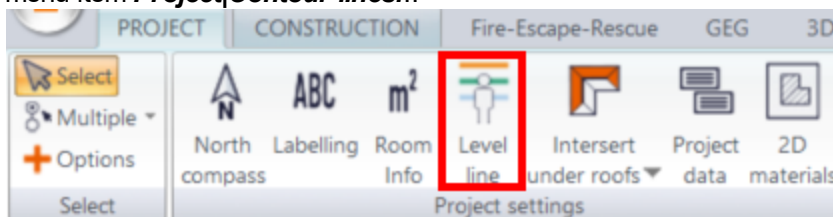

## 11.5 Roof intersection

You can find information about trimming roofs here

[Trimming roofs](#)

## 11.6 Project properties

You will find the setting in the Project ribbon tab

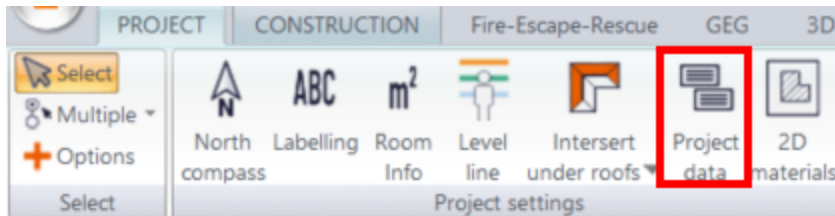

Enter the parameters for the planning office here. These values can be used as autotext in texts. All values are saved in the project file, default values are defined in the preliminary drawings ***standard.cad***

Project properties

Building project Design studio Project Documents

Design office :

Planner :  17.02.2025 ▾

Draftsman :

Checked :  02.02.2006 ▾

OK Cancel Report... Help

## 11.7 Level of detail\_view

In Plan7Architect, the 2D representation can be displayed in 3 levels of detail.

This applies to the 2D representation of walls, windows, doors, openings, stairs and roofs. The levels of detail available are **simple**, **medium** and **fine**. For each element, you can specify the level of detail at which which part of the 2D representation is shown and how. Further information on the settings can be found in the descriptions of the respective components.

The selection of which level of detail is shown can be defined in the Project ribbon under Detailing.

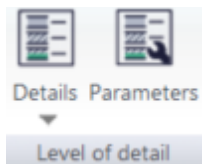

Select the level of detail in the selection list or in the **View|Level of detail** pull-down menu.

**Simple:**

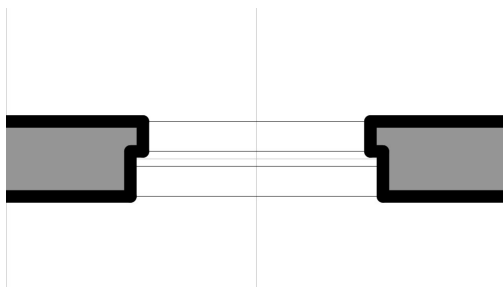

**Medium:**

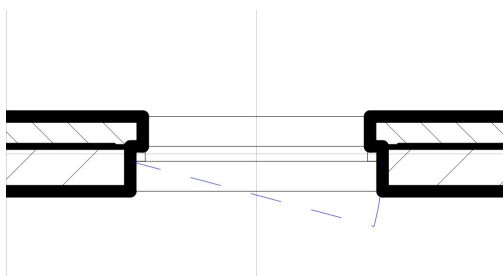

**Fine:**

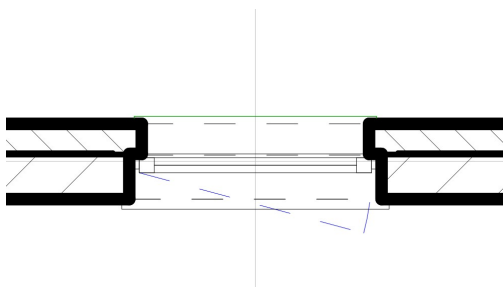

## 11.8 Level of detail\_default settings

The scales can be configured in the dialog in the **Project***Detail level* menu for scale-dependent detailing. With this option, the current screen scale can also be used as the basis for the detailing. If you zoom the drawing, the level of detail can be increased dynamically.



Parameters

In contrast to the current level of detail, a fixed level of detail can be preselected for some component types (walls, windows, doors, openings).

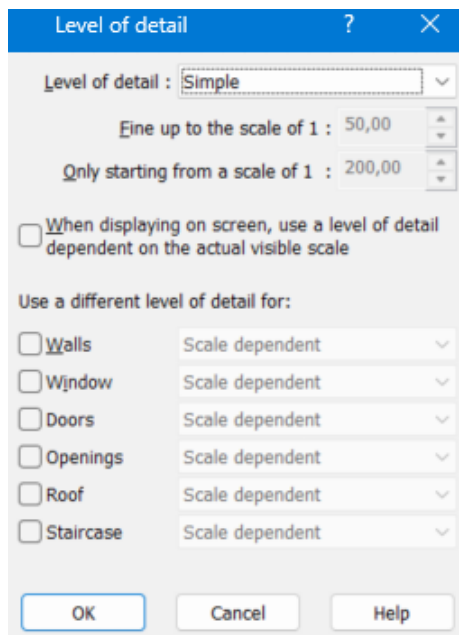

### Level of detail options:

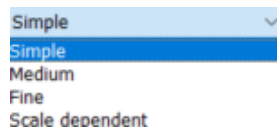

Simple  
Medium  
Fine  
Scale-dependent

## 11.9 External dimensions

All default settings for **automatic external dimensioning** are made here. The selection is made via the menu position **Project***Outer dimensions...*

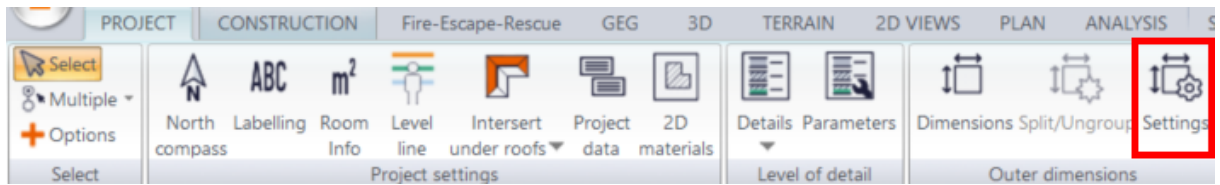

The visibility and the positions of the dimension chains are controlled under **Outer dimensions**

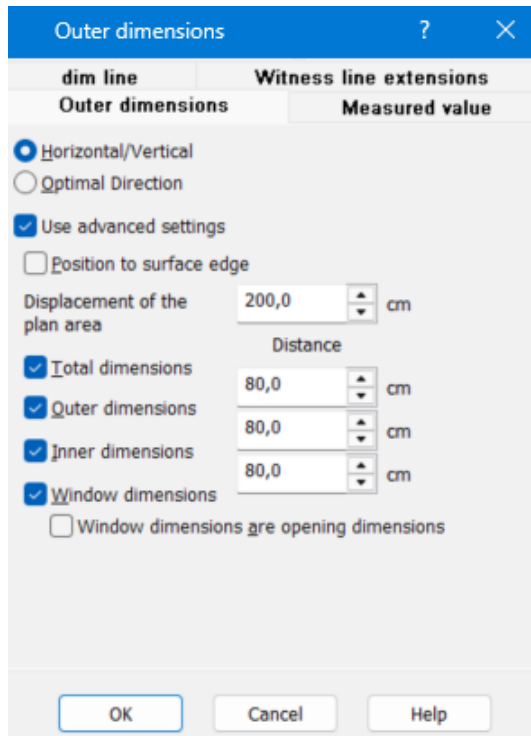

## 11.10 Master data synchronization

This is accessed via the menu bar under **Options|Master data synchronization...**

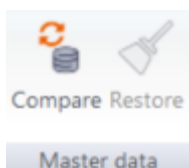

The settings for master **data synchronization** can be made here.

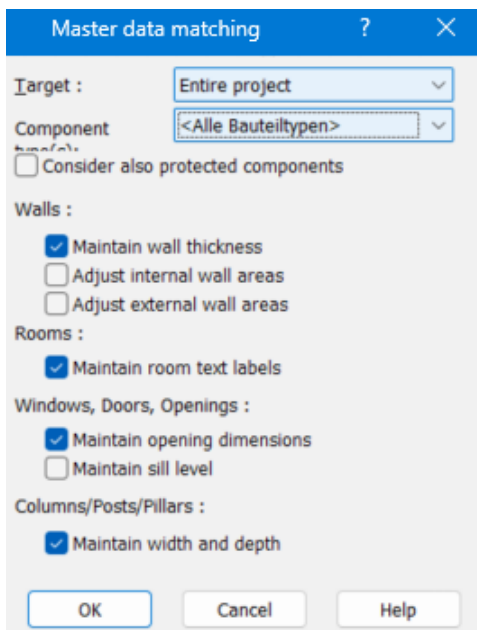

See also [-->Catalogs - component templates](#)<sup>1501</sup>

If part templates have been changed, existing projects are not updated automatically. This update to the latest version can be carried out with the master **data synchronization**. Certain parameters can be set.

## 11.11 Delete unattached rooms

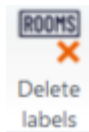

This function can be used to delete all unbound rooms in the project (also works via ALT+R). You can find out what unbound rooms are and how they are created here:

[Unbound rooms](#)<sup>4041</sup>

## 12 Ribbon construction

### 12.1 Walls

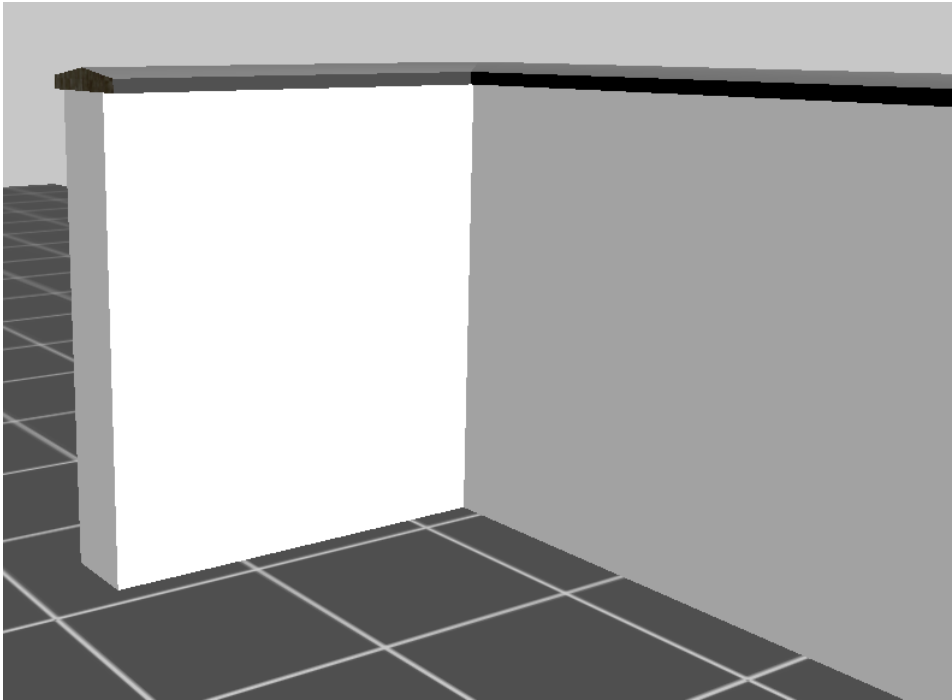

#### 12.1.1 Introduction

##### 12.1.1.1 Representation in floor plan

A wall is made up of one or more wall layers. These layers have properties such as filling, hatching and line type, etc. This wall structure is set in the **Construction** properties dialog.

However, it is not always desirable to display this wall structure in the planning, which is why the wall itself also has properties such as hatching, filling and line type; set in the **2D representation** of the wall properties dialog. These wall properties always apply to the entire wall, even if the wall structure = the wall layers are not shown.

This means that there are two display options for a wall:

1. Simple level of detail - no wall structure is shown, the entire wall can be filled or hatched.



Simple detailing

2. Medium or fine level of detail - the wall layers are shown with the properties intended for them.



Detailing medium or fine

Please note that the properties of the wall contour apply to both display variants.

### 12.1.1.2 Wandsegmente

Each wall has wall segments. A free-standing wall of constant thickness has four segments, for example. More or even fewer can be created by intersecting with other walls or virtual walls. Wall segments are important for the assignment of material properties for the 3D model and the area evaluation according to DIN277 (variable plaster thickness per wall segment).

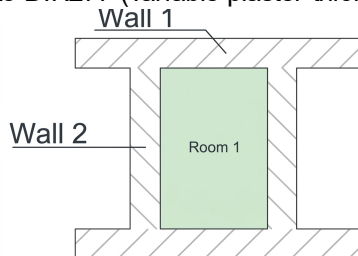

Wall 1, for example, has six wall segments, wall 2 only two.

### 12.1.1.3 3D representation

You draw a wall in construction mode. This wall is then also shown in the 3D view. 3-dimensional surfaces are created for each wall segment, which can also be covered with different materials.

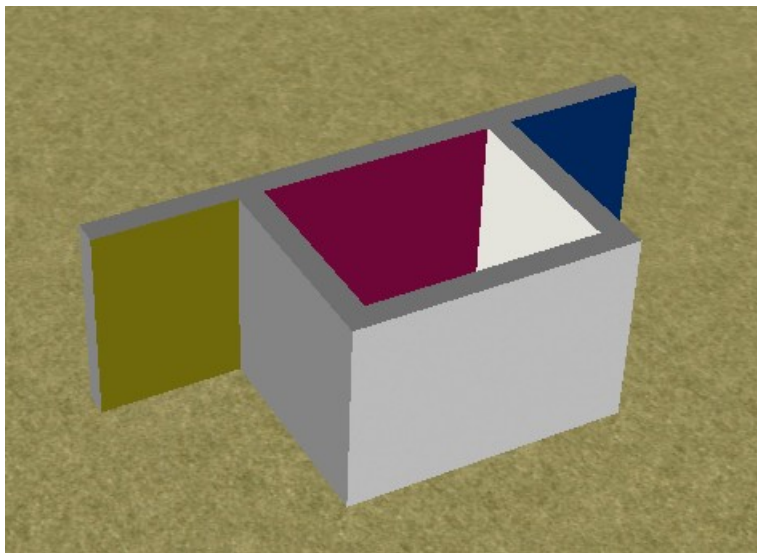

### 12.1.1.4 Influence on other components

#### Walls

A wall is intersected with other walls as soon as the wall polygons overlap. This changes the number of wall segments, the corner points are displayed correctly and special cases such as facing walls etc. are very easy to construct.

Examples:

Two walls correctly intersected result in an L-node

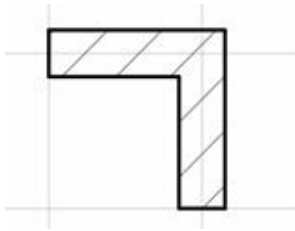

Two parallel walls correctly arranged result in a wall projection

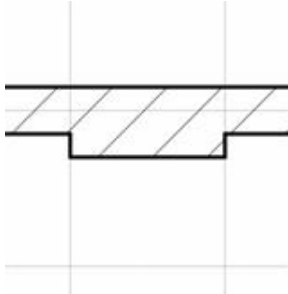

### Virtual walls

Virtual walls divide wall segments at the point of intersection.

### Rooms

Rooms are only created by drawing walls as soon as at least three walls form a closed polygon. If you delete a wall, this polygon can be opened if necessary and the room is also deleted.

### Windows, doors and recesses

These components are always placed on walls or virtual walls. They remain independent components with their properties, but if you delete the wall, all the openings it contains are also deleted.

### Roofs

Walls are blended under roof surfaces, unless these properties are deactivated under **Construction/Levels**.

### Stairs

The height of walls can be intersected under flights of stairs if this property is activated under **Construction/Levels**.

#### 12.1.1.5 Important shortcut keys

The position of straight walls is always determined by two points, the starting point and the end point of the wall. These two points form the reference axis. When drawing a new wall, you can use the **W** button to select or change the position of the reference axis (left, center or right).

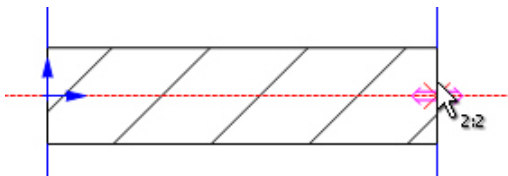

Center reference axis

Use the **Q** and **E** buttons to select the reference axis for the start point and end point of the wall separately.

### 12.1.1.6 Wall axes

The display of the wall axes can be switched on and off in the view bar in the extended view functions.

When the wall thickness is changed, the position of the wall is defined in relation to this axis.



The arrow on the wall axis shows the direction of the wall from the starting point to the end point. The position of the axis can be defined via the dialog bar:

Wandachse ▾

You can choose between the inside and outside of the wall axis.

The inner side is clearly defined for a wall that borders on a room.

In the case of an interior wall (rooms on both sides) or a free-standing exterior wall, the interior side is always on the right.

(viewed in the direction of the drawing)

#### Options for wall axis

Open the dialog in the pull-down menu under **Options|Wall axis...**

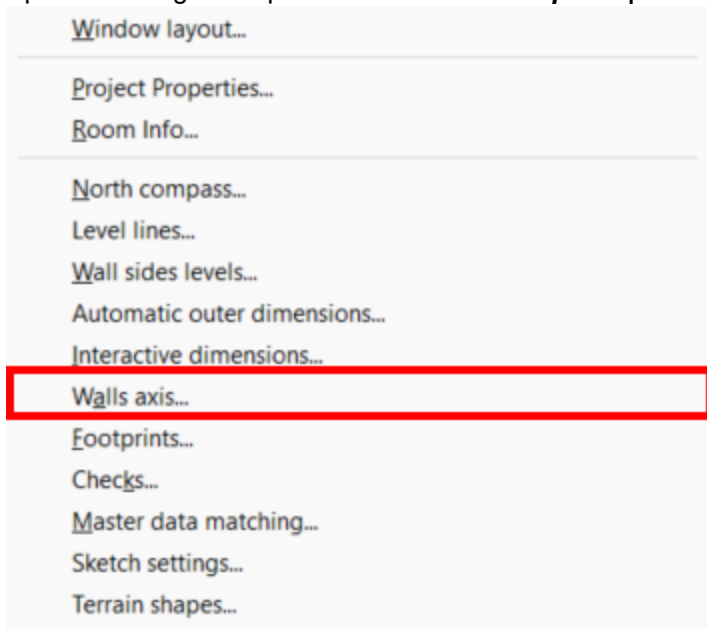

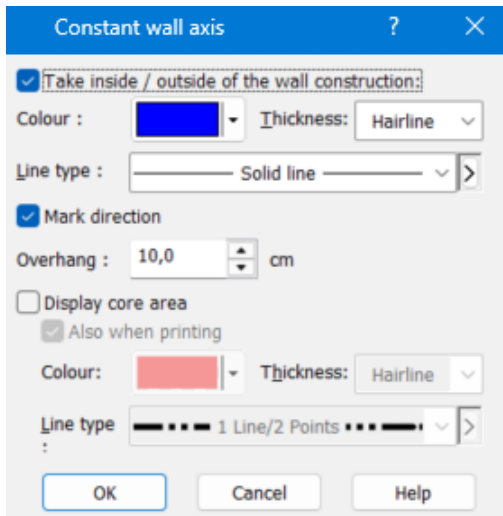

In this dialog, you can define the display of the axis, the projection and the visibility of the direction arrow. The option Take inside/outside from wall construction means: In the Construction dialog, you can optionally specify that for the layered construction of a wall.

## 12.1.2 Wall input

### 12.1.2.1 Drawing

Click on the **Wall** button.



Wand

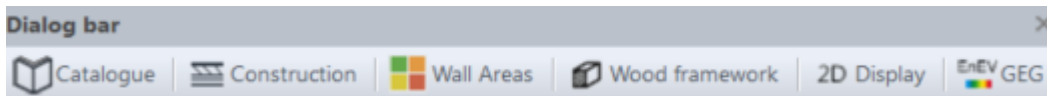

All headings of the properties dialogs available for walls are listed.

An overview of the properties dialog for drawing walls, starting from the left:

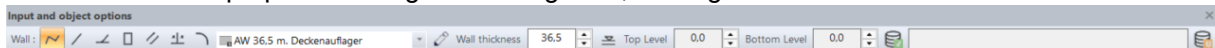

**Input options:** 

Specify here whether the wall should be drawn with an offset.

#### Input type





This selection bar lists the options for placing one or more walls.

- **Draw walls polygonally**  
You set the starting point and the end point of the first wall. The end point of the predecessor is used as the starting point for all further walls. End the input with **[Esc]**, only now are the drawn walls intersected with the rest of the planning and any new rooms created. To cancel the action during input, select **Cancel function** from the context menu.
- **Drawing a simple wall**  
You set the start point and the end point of the wall in the planning. The wall is created. If required, you can continue with the starting point of the next wall.

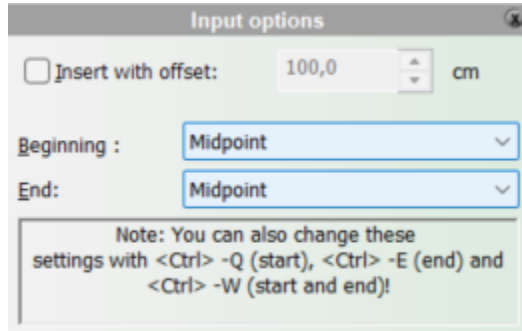
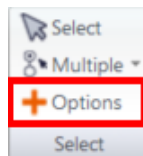
With the simple wall, there is the additional option of defining the thickness with a further mouse click.



- **Draw in angled wall**  
Select this input type and specify the angle in the input options. Then move the mouse pointer over any element in the drawing. The axis is displayed. Click on the desired position and the start and end points of the wall will be placed on this axis.
- **Draw vertical wall**  
Works in exactly the same way as the *angled wall input* type, but the new wall is always perpendicular to the reference edge.
- **Move parallel wall**  
Places a wall parallel at a fixed distance to an element that has already been drawn.
  1. Select the edge to which the wall should be parallel.
  2. Enter the value for the desired distance.
  3. Click on the side of the edge on which the wall should lie.
  4. Determine the position of the start and end points.
- **Draw in a centered wall**  
Click on two input points between which the wall is to be drawn in perpendicular to them in a specific division ratio. An auxiliary line is displayed on which the reference axis of the wall will lie. Set the start and end points of the wall.  
You specify the value for the division ratio in the input options .
- **Round wall**  
You can use this function to subsequently round off 2 existing walls.  
Use the first two input points to specify the walls to be rounded. Use the 3rd input point to specify the radius of the rounding.  
The rounding is created from individual wall segments. You specify the maximum segment length in the input options .

Component **template:** 

The name of the current component template is displayed.

In this selection list, choose which template you would like to use for the new wall. The ten most recently used templates are listed. If the template you require is not listed, select **Catalog**,

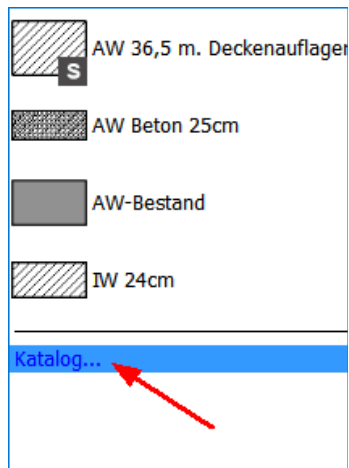

to select from all existing templates

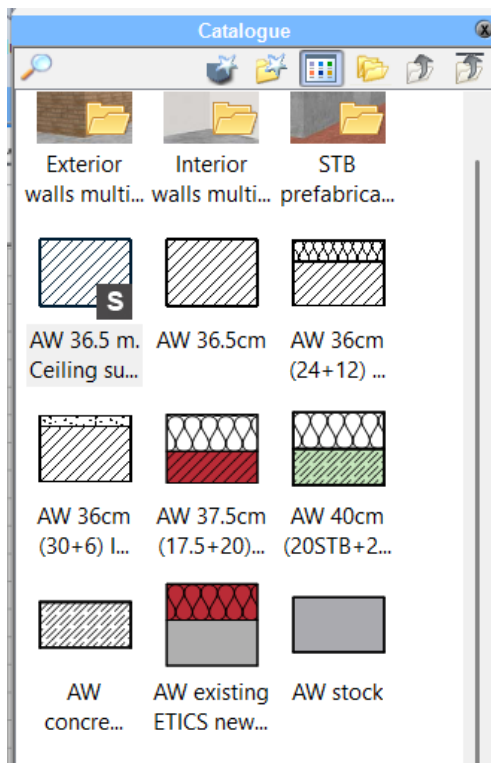

to be able to select from all available templates.

Selecting a template, whether from the selection bar or the catalog, sets all properties of the new wall to the values of this template.

For this reason, all other entries, such as the wall thickness, should only be made after the desired template has been selected.

For example, if you have selected a **30 cm brick** wall template, the wall thickness will be set to **30 cm**. You could now also change the wall thickness, e.g. to **25 cm**, but this will not change the name of the template.

**Thickness:** The wall thickness is defined here.



**Contour:** Select the color, thickness and line type for the outer wall contour here. These settings have no influence on the display of wall layers.

**Hatching:** Select the desired hatching type here. Click on  to adjust the parameters of the selected hatching.

### 12.1.2.2 Numerical input

With the new numerical input, wall input is even faster and easier!

To switch this on or off, please click on the grid and snap options:

 on the last button:  with the right mouse button, the following dialog with input options appears:

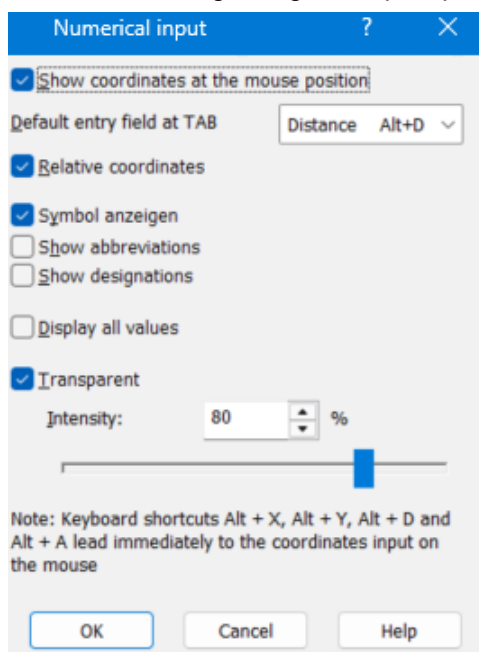

the displayed settings are extremely helpful!

The numerical input now hangs as a small toolbox directly on the cursor:

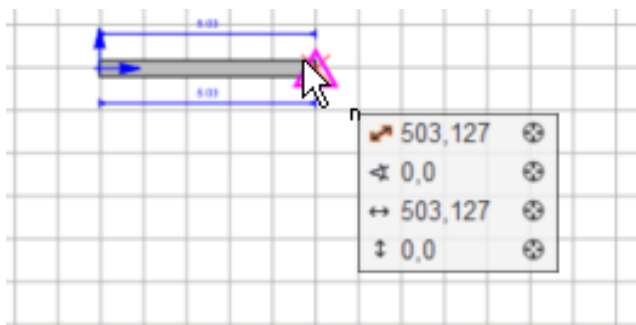

Set the first point with the mouse and specify the direction of the component, now you can either type in the length immediately or use the **[Tab]** key to jump through the 4 possible input options and enter the corresponding values.

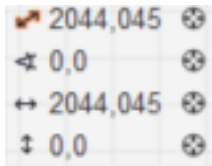

Confirm with a click of the left mouse button or with **[Enter]**!

This fixes the second point of the wall, which immediately determines the starting point of the next wall in the polygonal input.

Now you only need to specify the direction with the mouse and the numerical input can be made immediately.

You can also use the **[Tab]** key to jump directly to the desired input:

Distance :     **[Alt]+[D]**  
 Angle :        **[Alt]+[A]**  
 X-value :      **[Alt]+[X]**  
 Y value:       **[Alt]+[Y]**

### 12.1.3 Polygonal walls (polywall)

#### 12.1.3.1 Basics

A polygonal wall (polywall) is defined by entering a polygon. Straight and circular segments can be used.

What are polywalls used for?

Polywalls are used as soon as the required wall geometry does not require parallel wall sides or curves. This is particularly necessary when planning in existing buildings.

Examples of polywalls:

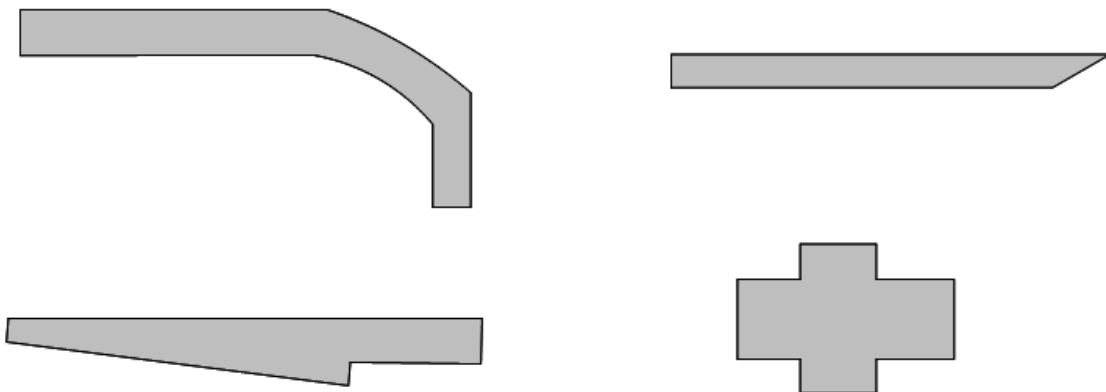

Polywalls are integrated into the automatic room search.

### **Polywalls and construction planes:**

Polywalls cannot currently be assigned construction levels.

#### **12.1.3.2 Input**

A polywall is entered in the same way as a 2D polygon.

You can find more information here:

[Input types](#) 5231

#### **12.1.3.3 Edit**

Subsequent editing is carried out in the same way as editing 2D polygons.

Further information can be found here:

[Editing polygons](#) 5251

#### **12.1.3.4 Masses**

Like all components, polywalls provide dimensions.

Volumes, wall surfaces, etc. are determined with dimensional accuracy.

However, quantity approaches such as wall length can only provide the dimensions of the surrounding rectangle.

#### **12.1.3.5 Wall structure**

The Wall structure dialog for poly walls differs from the dialog for standard walls.

The settings for wall layers are not yet relevant. Polywalls only show the innermost core wall layer.

For circular segments, the length of the segments can be set in 3D mode. The smaller the segment radius is defined, the shorter this length should be set.

Values from 5 cm to 200 cm seem sensible.

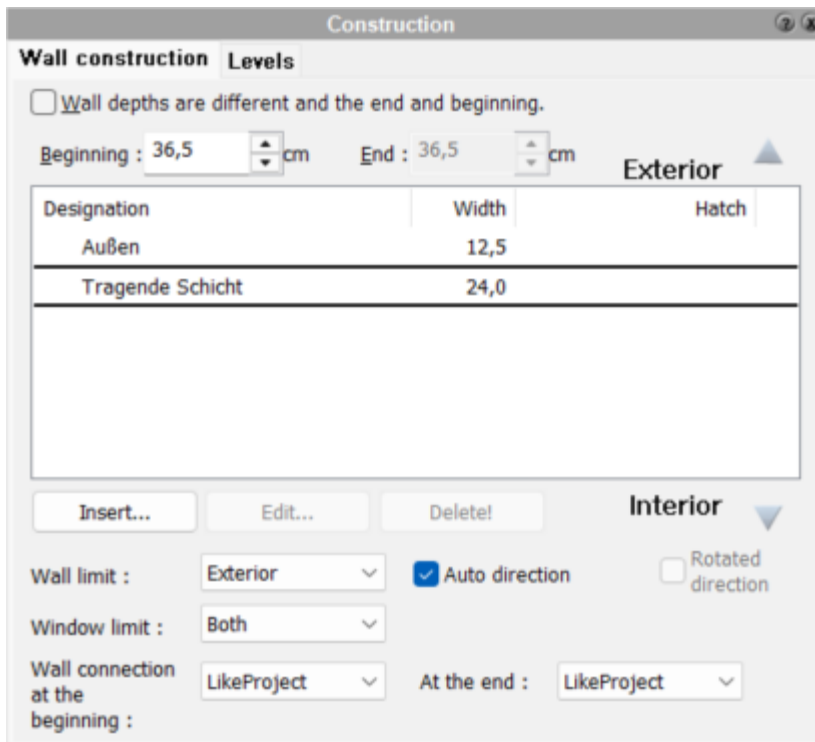

Define outer and inner sides:

If this option is activated, the segments are numbered consecutively. In the input fields, you can specify which segments are to be used for the inner contour or the outer contour. For free-standing polywalls, the windows (doors) can be used more effectively.

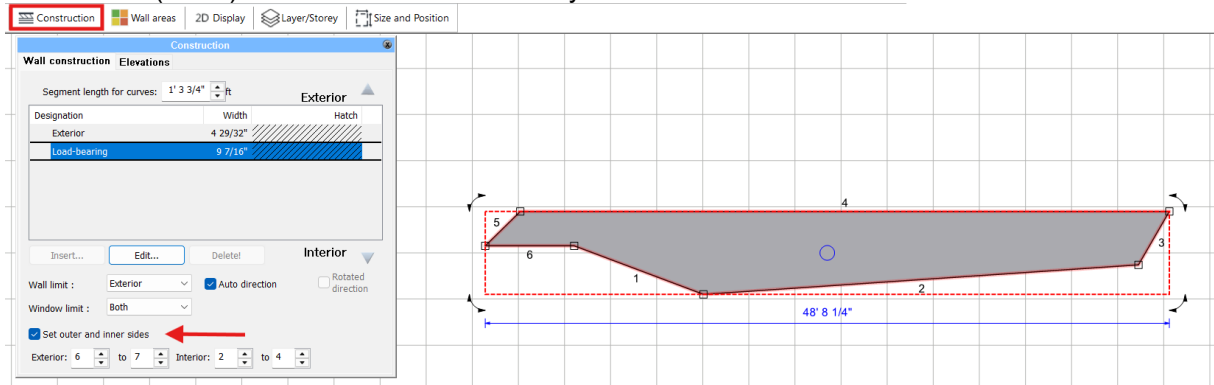

### 12.1.4 Property dialogs for walls

In these properties dialogs, you will find all the parameters of the wall, including the parameters of the dialog line.



### 12.1.4.1 Catalogue

Wall units that are used frequently are stored in the **catalog**.

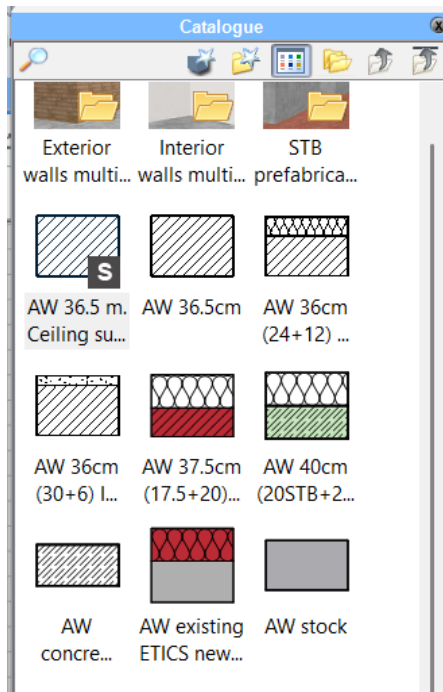

You can find more information on [catalogs](#)<sup>1501</sup> in the chapter [General properties dialogs](#).<sup>1341</sup>

### 12.1.4.2 Construction

The **Construction** dialog is divided into two tabs: Wall **structure** and **Levels**

**Wall construction:**

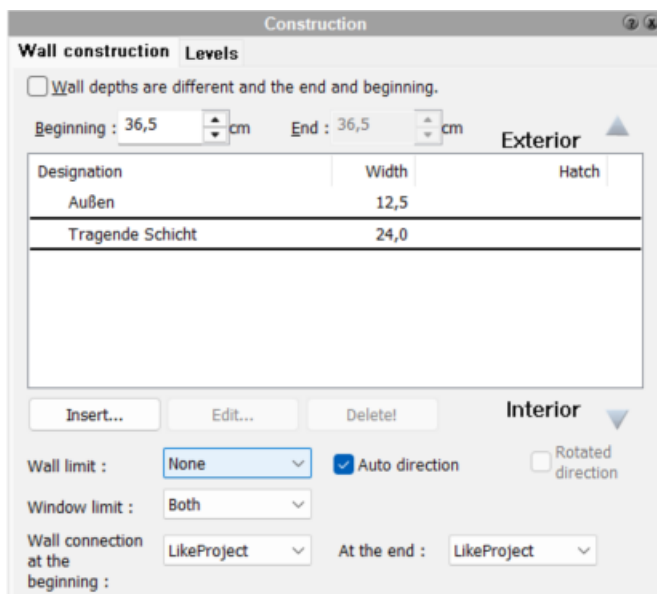

The **Allow different wall thicknesses at the start and end of the wall** selection is only activated if conical walls are drawn. Click on the selection box and enter a different thickness for the end of the wall.

The list shows the wall structure with the individual layers of the wall.

### Adding a new layer

Click on the **Insert** button to add an additional layer to the wall structure. The dialog with the properties of the new layer opens:

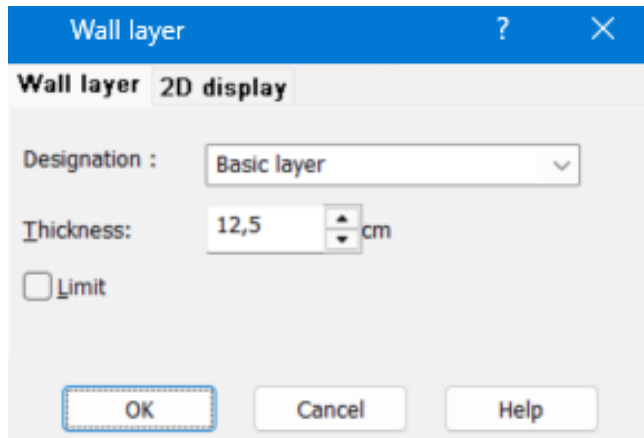

Select a name from the selection list; different names are simply entered in the selection list. Set the desired thickness of the layer. The **End** option is activated if the layer is to be routed across corners for wall or window connections.

The contour, fill and hatching properties can also be set for this layer.

### Edit existing layer

Click on a layer in this list. The line of the selected layer is highlighted and can now be changed by clicking on **Edit**. Double-click on the line to achieve the same result. The **Wall layer** form opens. The dialog is explained in the previous section.

### Deleting an existing layer

Select the desired layer and click on **Delete**. The layer is deleted from the wall structure and the wall thickness is adjusted.

### Wall finish

All layers of the wall are drawn across the corner at the wall ends as soon as the **End** option is activated; the side can be defined in the **Wall end** selection bar. This only applies to free-standing wall ends.

### Window end

For all window and door openings, wall layers are led over the corner on the inside, outside or both sides. Of course, the option of the layer **closure** must be active again for this.

### Determine direction automatically

In this dialog, the outer edge of the wall is always at the top. The position of the outside must first be determined in the drawing. If this option is active, this is done automatically; if a room is created on one side of the wall and not on the other, the room side is on the inside. If rooms have been created on both sides or on neither side, the position of the "outer edge" depends on the drawing direction. You can subsequently change the outside by switching off the automatic function and correcting the direction using the adjacent option, which is now active.

**Reverse direction****Wall connection at the beginning****Wall connection at the end****Levels**

The ***Do not intersect with other walls*** option means that the corresponding wall is not intersected with any other wall on the storey. The room areas are not reduced.

If the ***Intersect under stairs*** option is activated, this wall is limited in the height of stairs along the bottom edge of the running slab.

The option ***Do not intersect under roofs*** deactivates the limitation of the wall height under roofs.

***Levels that deviate from the storey height*** can be set separately for the upper and lower levels for the left and right heights. Left is the first point entered by the wall.

The level can be set as follows:

- ***Relative to storey levels:*** Use this setting if the height of the wall is defined with an offset measured relative to a storey level, e.g. the top edge of the wall should be 30 cm below the ceiling. Enter -30 cm for the upper level *relative to the lower edge of the storey ceiling* and -30 cm as the offset.
- ***Absolute:*** If this height specification is selected, the upper or lower edge is specified as an absolute value. The height of the absolute zero point cannot be changed, but the absolute height of the storey can be set. (*storeys|edit active storey|level top of floor*)
- ***relative to the lower level:*** this option is only available when editing the upper level. Use this setting to define a fixed height for a wall, regardless of the storey height.

### 12.1.4.3 Wall surfaces

#### Materials

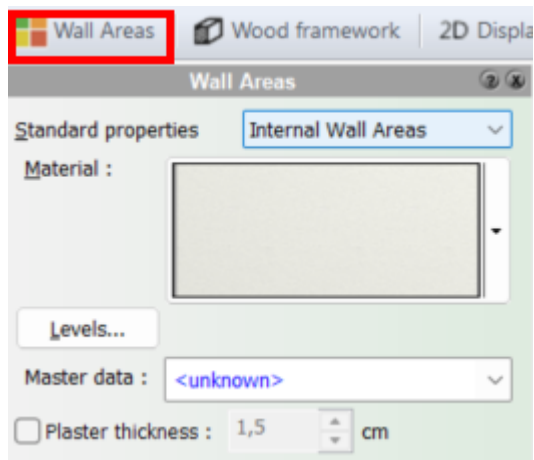

Select the standard materials for inside and outside in this dialog. This material is used as soon as new wall surfaces are created, so you do not change your current planning. These settings are particularly important for component templates.

Further information can be found at [Surface](#)<sup>[138]</sup> in the [General properties dialogs](#)<sup>[134]</sup> chapter.

### 12.1.4.4 2D Representation

The [contour](#)<sup>[138]</sup>, [filling](#)<sup>[140]</sup> and [hatching](#)<sup>[141]</sup> of the wall are set in this dialog. This display is only shown if no wall layers are displayed. This is normally the **Simple** level of detail, unless otherwise selected under **ProjectParameters**

You have the option of setting a level of detail for the entire project or using a different level of detail for walls, windows, doors and openings.

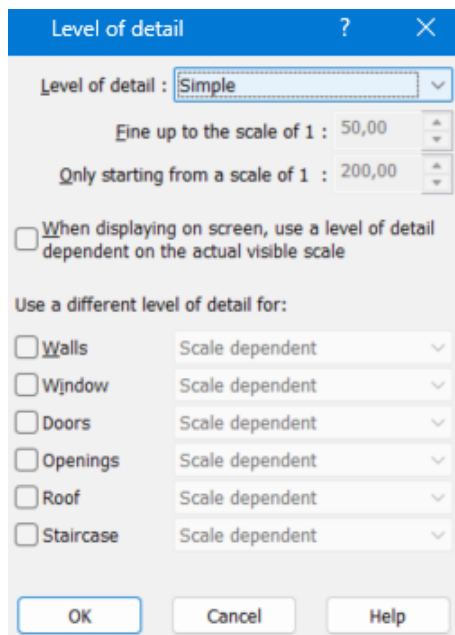

Options: Simple/Medium/Fine/Scale-dependent

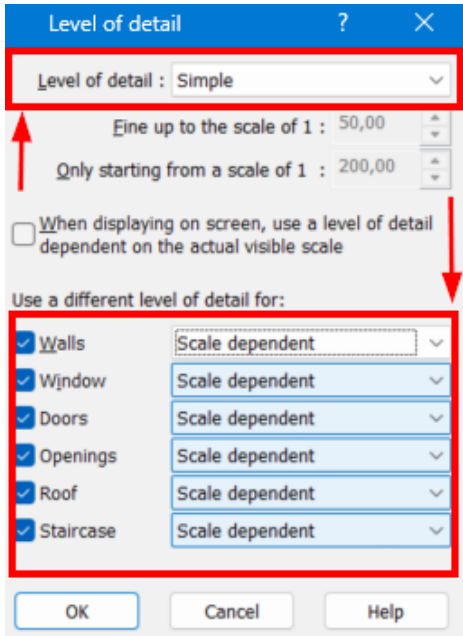

**Level of detail options:**

- Simple
- Medium
- Fine
- Scale dependent

**12.1.4.5 Properties**

Further information on the [properties](#)<sup>[145]</sup> can be found in the [General properties dialogs](#)<sup>[134]</sup> chapter.

**12.1.4.6 Layer/Floor**

You can find further information on [layers/floor](#)<sup>[143]</sup> in the [General properties dialogs](#)<sup>[134]</sup> chapter.

**12.1.4.7 Size/Position**

Further information on [size/position](#)<sup>[143]</sup> can be found in the [General properties dialogs](#)<sup>[134]</sup> chapter.

**12.1.5 Editing walls**

**12.1.5.1 Extend**

Go to **Trim|Extend**

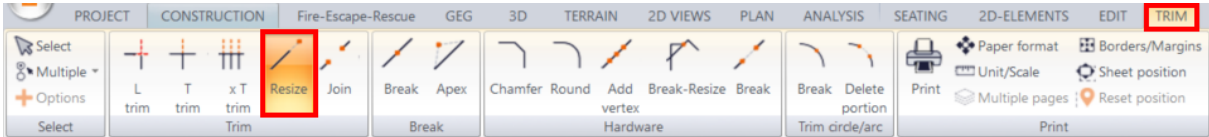

Now select the desired wall

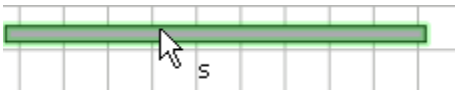

and lengthen or shorten it accordingly (you can enter precise values via TAB).



### 12.1.5.2 Move

The **Move** command is described in the "Editing" chapter. To move a wall directly with the mouse, you can click on the corner points and edges of the wall; these are highlighted in red. If you only want to move a wall, you can 'drag' it without clicking by holding down the left mouse button (keep the button pressed).

see --> [Editing tools](#) <sup>541</sup>

### 12.1.5.3 Trimming

Walls can be trimmed using the trimming functions **Trim (L)**, **Trim (T)**, **Break up** and **Extend** trimming functions  are described in more detail in the **Trimming** chapter.

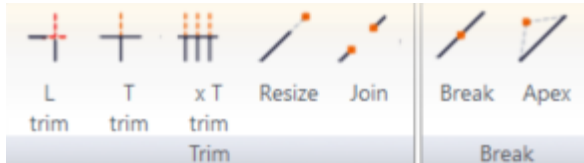

See --> [Trimming tools](#) <sup>555</sup>

## 12.2 Virtual walls

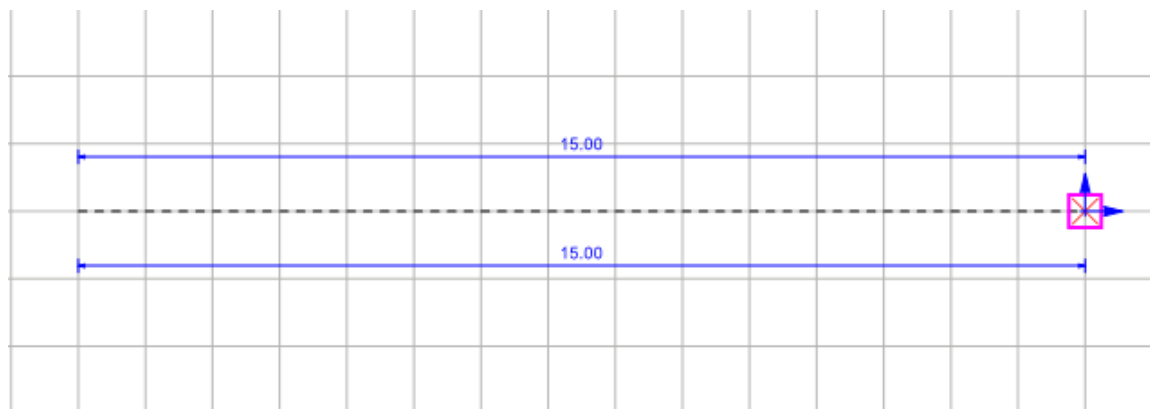

Plan7Architect automatically recognizes whether an area is completely surrounded by walls and then defines a room for this enclosed area.

It may now be necessary to define rooms that are not enclosed on all sides.

The principle is simple: you create a **virtual wall** like a normal wall. The differences: in construction mode, the virtual wall is displayed as a line; in 3D mode, a virtual wall is invisible.



## 12.2.1 Property dialogs



The [Contour](#)<sup>1381</sup> properties dialog enables all settings for the floor plan display of the virtual wall.

The properties dialogs **Wood construction** and [Levels](#)<sup>2331</sup> are the same as the properties of the normal wall.

The dialogs are described in the [Wall](#)<sup>2381</sup> chapter. Timber constructions for virtual walls are shown in 3D mode as a matter of course.

### 12.2.1.1 Catalogue

In the catalog

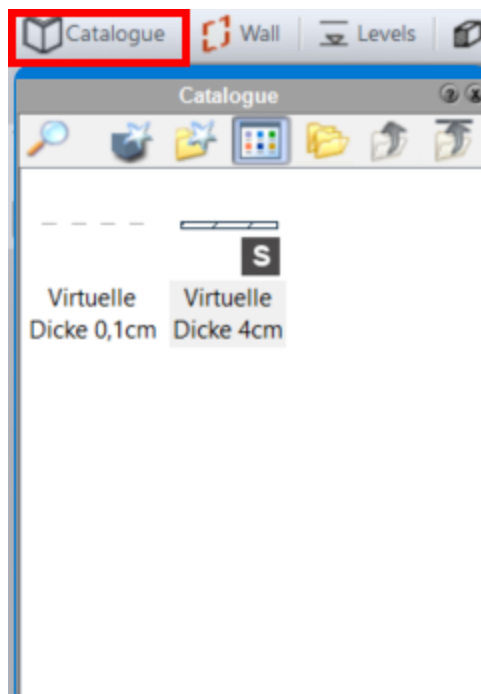

virtual walls that are used frequently are stored in the catalog. Further information on the [catalogs](#)<sup>1501</sup> can be found in the [General properties dialogs](#)<sup>1341</sup> chapter.

### 12.2.1.2 Wall

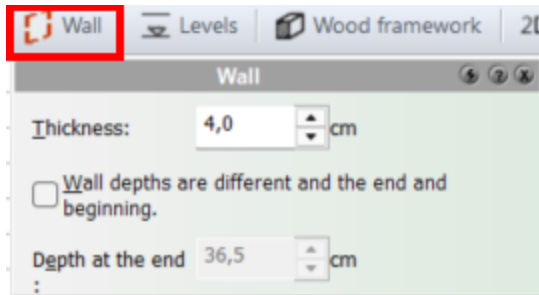

The thickness of the virtual wall is set in this dialog. If the end of the wall is to be given a different value, select the corresponding option.

### 12.2.1.3 Levels

Further information can be found in the chapter [Property dialogs for walls](#)<sup>[230]</sup>, under [Construction](#)<sup>[231]</sup>.

### 12.2.1.4 Contour

You can highlight the virtual walls using various contours. The arrow button to the right of the Pattern selection field opens an additional input window in which you can change the sizes of the individual tiles and the proportions of the various components. The result is displayed in a preview.

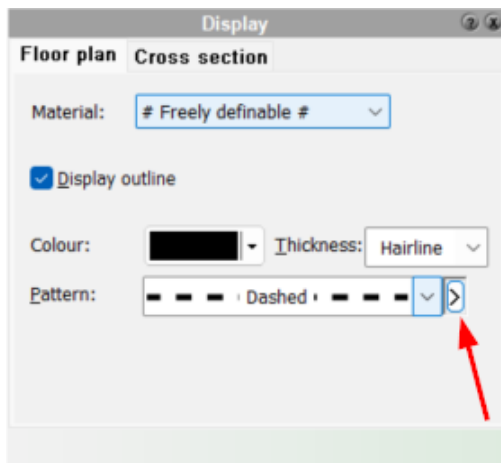

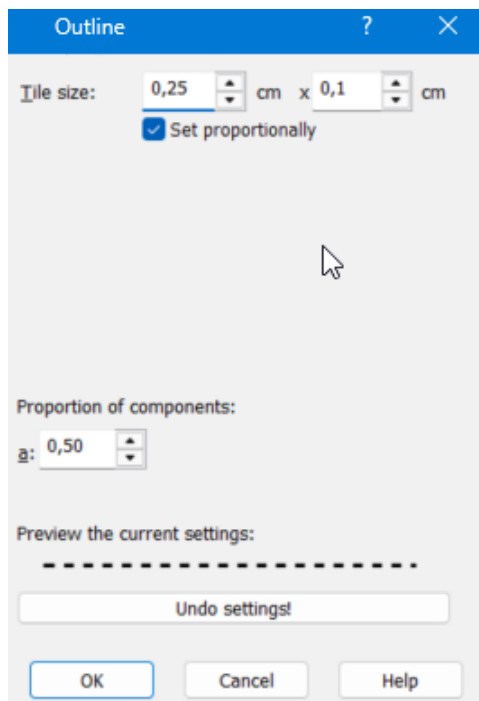

#### 12.2.1.5 Properties

Further information on the [properties](#)<sup>[145]</sup> can be found in the [General properties dialogs](#)<sup>[134]</sup> chapter.

#### 12.2.1.6 Position number (PosNr)

Further information on the [position number](#)<sup>[147]</sup> can be found in the [General properties dialogs](#)<sup>[134]</sup> chapter.

#### 12.2.1.7 Layer/floor

You can find further information on [layers/floor](#)<sup>[143]</sup> in the [General properties dialogs](#)<sup>[134]</sup> chapter.

#### 12.2.1.8 Size/position

Further information on [size/position](#)<sup>[143]</sup> can be found in the [General properties dialogs](#)<sup>[134]</sup> chapter.

### 12.2.2 Tips

As virtual walls and real walls as well as floors and ceilings are virtually cut open, it is possible to use different materials for these cut-open areas. For example, you can use virtual walls to section off part of a room and then texture the floor differently to the rest of the room. The same applies to walls.

## 12.3 Supports

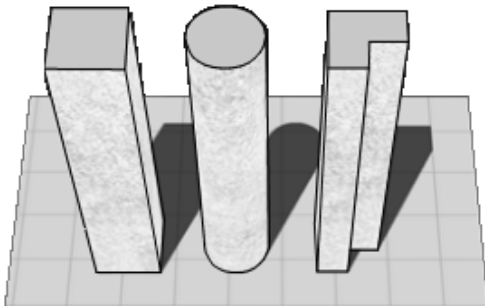

### 12.3.1 General information

A column is represented in plan by a closed contour. For the 3D representation, surfaces are created vertically along this contour; the base and cover surfaces are closed. The height of a column depends on the storey heights (normally the lower edge of the column is equal to the upper edge of the bare slab, the upper edge is equal to the lower edge of the bare slab above) or can be freely selected.

The 2D representation is designed using the properties of the contour such as line type, line color and line width as well as the properties of the surface such as hatching and filling.

In the 3D model, you can assign your own materials to the side surfaces as well as the base and cover surfaces.

Plan7Architect distinguishes between two basic techniques for entering supports:

- rectangular or round supports
- Polygonal columns

Rectangular or round columns are so-called standard cross-sections. They are always available for selection, but are limited in terms of modification options (e.g. no additional corner points can be inserted). In contrast, polygonal columns can represent any cross-section; however, the cross-section must be constructed point by point.

Points of polygonal columns can be moved freely.

The following sketch shows a polygon support (e.g. drawn with input type **rectangle** 2points). The lower corner points were subsequently moved. This would not be possible with rectangular columns.



## 12.3.2 Draw supports

Clickon the **Column** button  in Construction mode.

### Catalog for component templates

The easiest way to define all the parameters of the new support is to select a corresponding component template from the catalog. To do this, open the catalog and click on the relevant template.

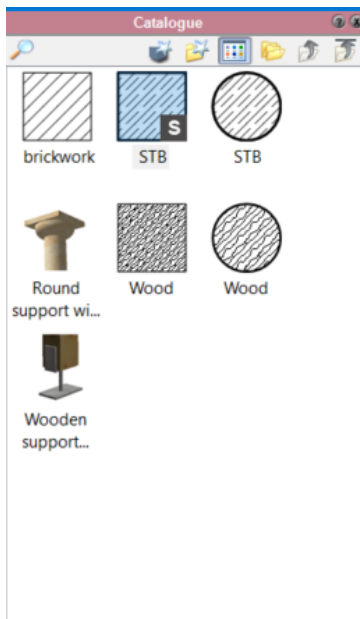

All values from the template are adopted and the column can be placed in the drawing.

- The column is displayed with its cross-section at the cursor.
- Press W until the desired reference point on the column cross-section is used.
- Now position this point in the planning; either freely, by snapping to an existing point or by entering coordinates.

Of course, all parameters can also be changed after assigning a template.

Further information can be found in the **General properties dialogs** chapter.

### Setting individual parameters

Settings that must be checked before drawing a support:

- the top and bottom edge can be defined in the Column properties dialog, default setting = same as storey
- the material for the 3D representation from the Material properties dialog
- Contour, filling and hatching from the respective dialogs for the 2D representation

### Is the column rectangular, round or any polygon?

Select the input type **Column** from the selection list if the column is to be rectangular or round, otherwise please select the desired polygonal input type.

Place column: 

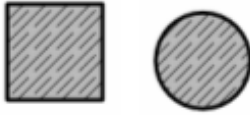

- Select **Support** type in the selection list
- Choose between square and round and select the material
- You can now place standard supports

Place rectangular column:

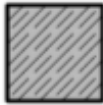



- Select **Rectangular** in the Type selection list
- Change the values for width and depth according to your requirements
- The column is displayed with its cross-section already at the cursor.
- Press W until the desired reference point on the column cross-section is used.
- Now position this point in the planning; either freely by snapping to an existing point or by entering coordinates.

Draw polygonal columns:



In contrast to the previous options, no width and depth can be entered for polygonal columns. Select one of the options from the **Input type** selection list :

- **Support (rectangle)** (2 points) - The input is made via the diagonal of the rectangle.
- **Support (rotated rectangle)** (3 points)  - The rectangle is defined using three points. This means that rotated rectangular cross-sections can also be entered directly.
- **Support (polygon with fixed width)**  - You define any polygon, open or closed (points 1-4). The column with a fixed width is added to the cross-section parallel to this polygon. The width is set in the **input options**.

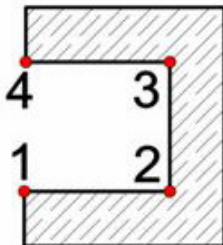

- **Column (polygon)** - This input type allows you to construct a polygon column by entering any number of corner points. The polygon is closed automatically. To do this, press F for finish or click on the starting point of the contour again as the last point.
- **Column (spline)**  - Define the points of the spline contour of the support. The contour is closed by pressing the **F** button.



### 12.3.3 Change supports

Left-click on the column (in the floor plan or in the 3D view).

The toolbar Input options



and the dialog bar

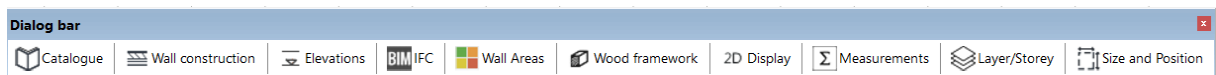

dialog bar for this column is displayed. Change the parameters of the dialog bar or open the desired properties dialog.

All changes are shown immediately in the planning. The properties dialogs are explained in more detail below.

#### Assign component template

Open the catalog and assign all parameters of the template to the current support by clicking on the corresponding template.

#### Change size

Select the column and change the Width and Depth values in the **Size/Position** dialog box.

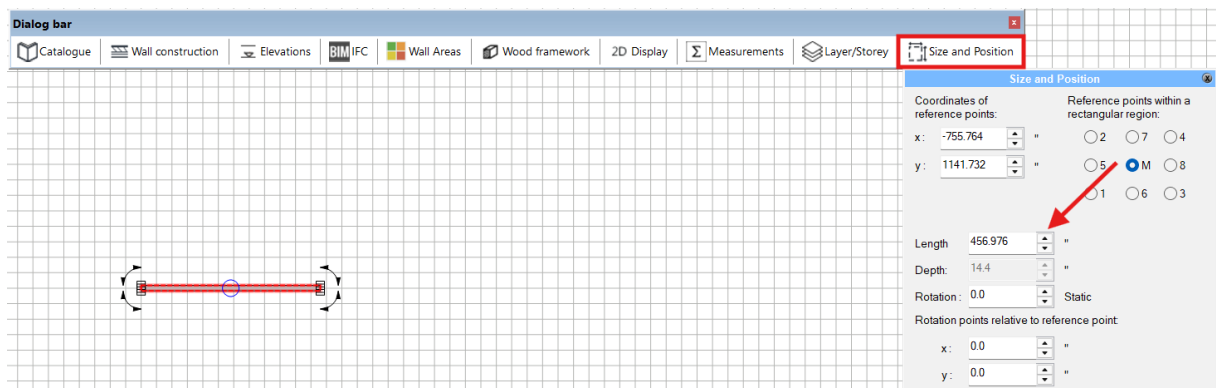

Please note that in the case of polygon supports, the circumscribing rectangle is changed and all points within this rectangle are changed proportionally. The *Maintain proportion* radio button in the *Size and position* properties dialog determines whether the ratio of width to depth is maintained.

**Only for polygon supports: Move points**

Move the cursor over the desired point of the unselected support. The corresponding point is marked with a rectangle. Now click on the point with the left mouse button and drag it to the desired position. Point snapping is supported at this point.

**12.3.4 Move supports****Moving with the mouse**

The easiest way to move a support is to select the support and move it by holding down the left mouse button. To ensure that the move can be entered precisely, select a corner point or an edge. To do this, move the cursor over the desired corner point or edge; the corner point/edge will be highlighted. (See illustration)

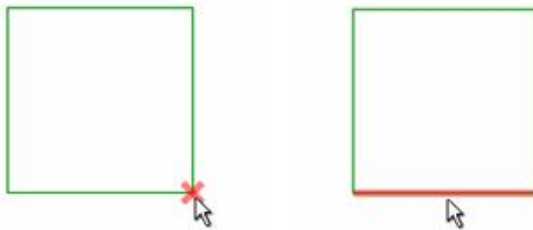

Now click on the element with the left mouse button and move the support to the desired position. It can be snapped to other points and edges of the drawing.

The advantage of this method is the higher working speed, as you do not have to switch to a separate command or dialog first.

**Further options:**

- With the **Size and position** properties dialog - see description **Properties|Size and position**
- With the **Move** command - see chapter **Editing tools**
- With the **online dimensions** - check whether the display of the online dimensions is switched

on. (Switch  in the grid bar (bottom right) or Online dimensions in the options). Select the support with the mouse. Click on the corresponding dimension and correct the value if necessary. The position of the support is adjusted immediately.

Tip: If the desired dimension is not displayed, as shown in the example below, move the prop closer to the "reference wall" using the mouse before entering the dimension. The desired dimension will then be displayed the next time you select it.

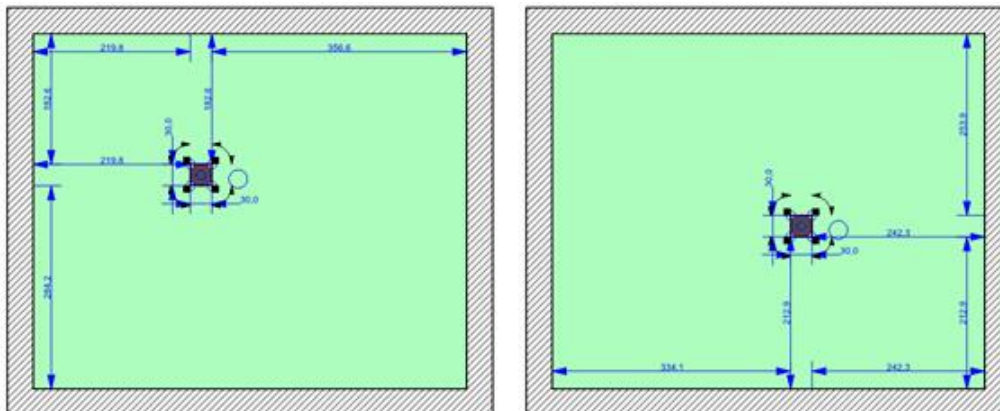

### 12.3.5 Cutting supports under roofs

Supports can be cut under roofs

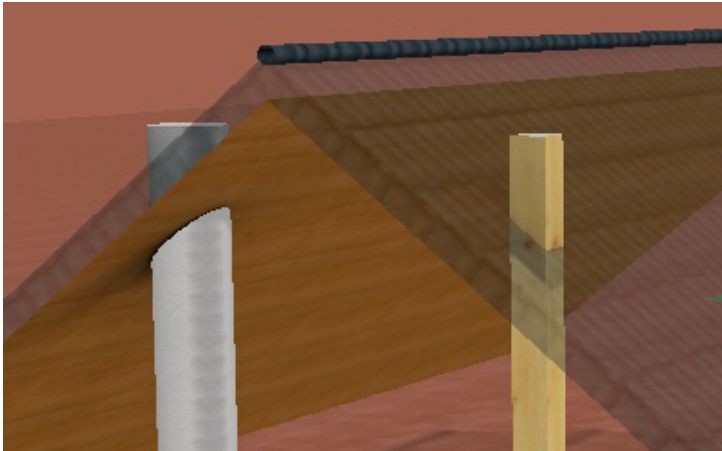

Activate the corresponding support and go to the container  
The corresponding option can be selected there:

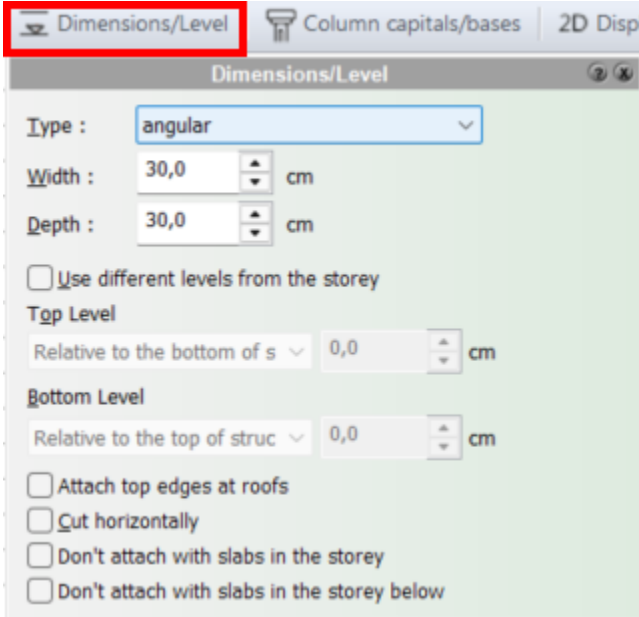

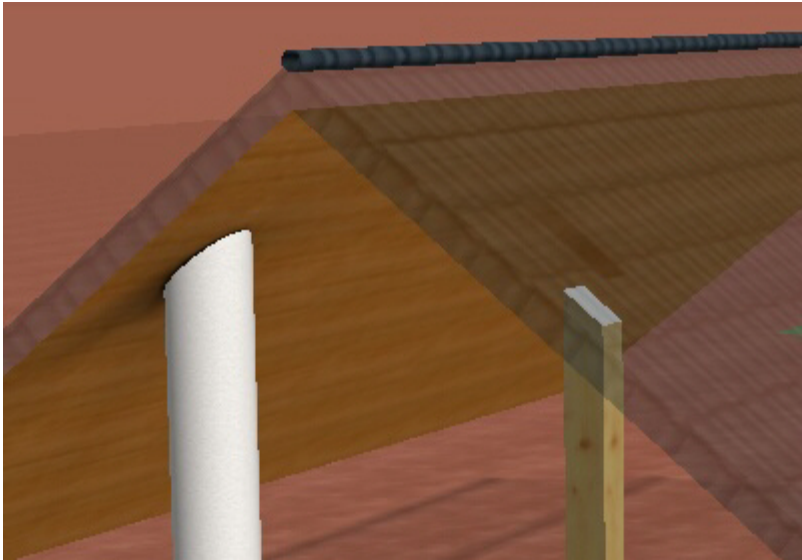

### 12.3.6 Delete supports

Select the support by clicking on it in the construction or in the 3D model. Press the **Remove** button or alternatively select **Delete** in the context menu.

### 12.3.7 Property dialogs

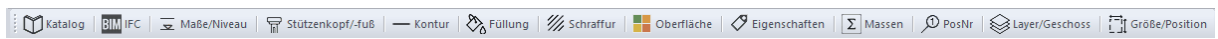

#### 12.3.7.1 Catalogue

Supports that are used frequently are stored in the catalog. Further information on [catalogs](#)<sup>150</sup> can be found in the [General properties dialogs](#)<sup>134</sup> chapter.

### 12.3.7.2 Dimensions/Level

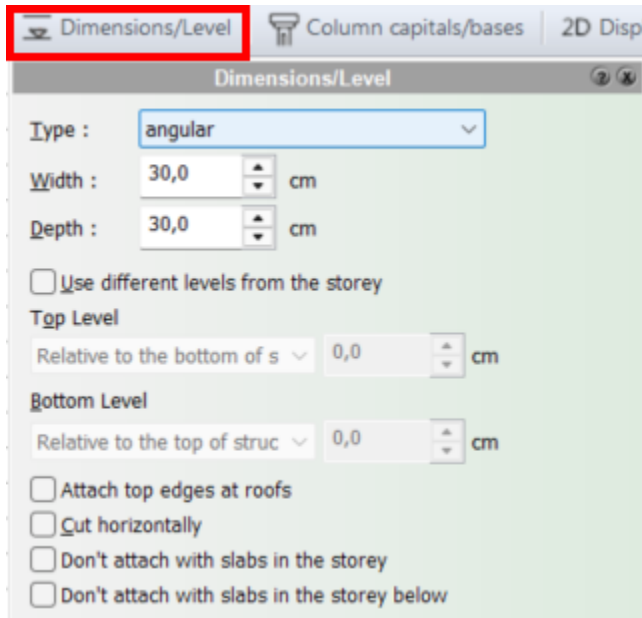

For rectangular or round supports, you can specify the dimensions and type (rectangular or round) in this dialog. The lower and upper level can be defined for all columns.

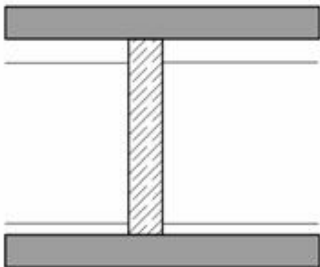

The column is drawn normally from the upper edge of the slab to the lower edge of the slab. If the storey heights change, the height of the column is automatically adjusted.

Deviating from the standard, the following heights can be defined:

- **Relative to storey levels:** Use this setting if the height of the column is defined with an offset measured relative to a storey level, e.g. the top edge of the column should be 30 cm below the ceiling. Enter -30 cm for the upper level *relative to the lower edge of the floor slab* and -30 cm as the offset.
- **Absolute:** If this height specification is selected, the upper or lower edge is specified as an absolute value. The height of the absolute zero point cannot be changed, but the absolute height of the storey can be set (*Storeys|Edit active storey|Top floor level*).
- **Relative to lower level:** This option is only available when editing the upper level. Use this setting to define a fixed height for a support, regardless of the storey height.

### 12.3.7.3 Support feet, Support heads

Click on the **Column head/foot** button in the dialog bar:

If you want to set a column base or head, please note that the levels of the column must be adjusted accordingly **beforehand**:

To do this, click on the **Dimensions/level** button in the properties dialog:

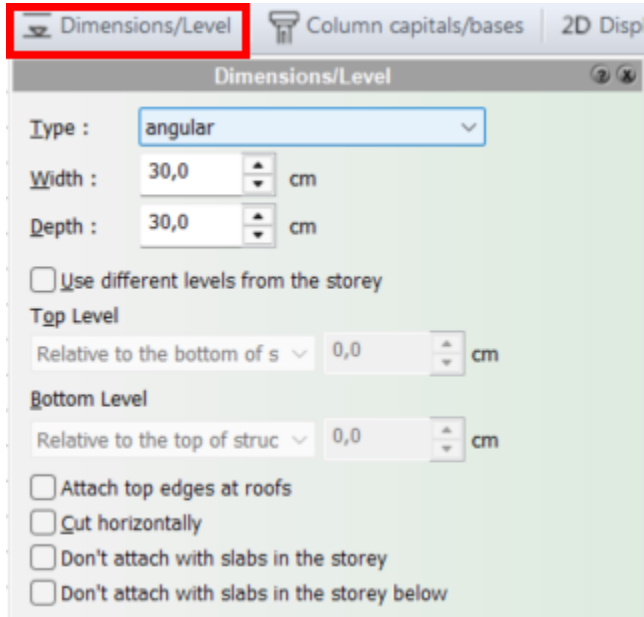

Once this has been done, the prop base can be selected using the **Prop head/foot** button:

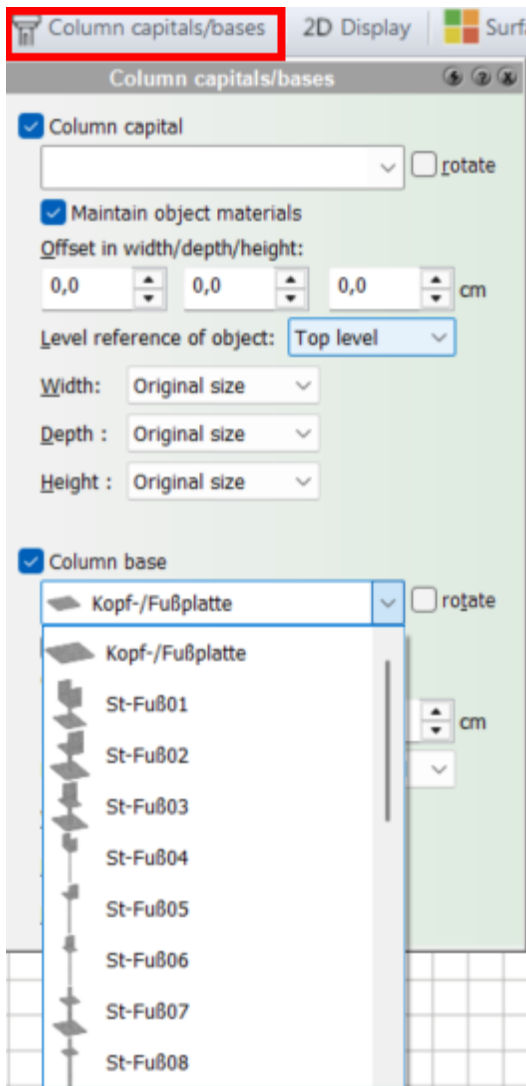

Once selected, it is possible to adjust some parameters:

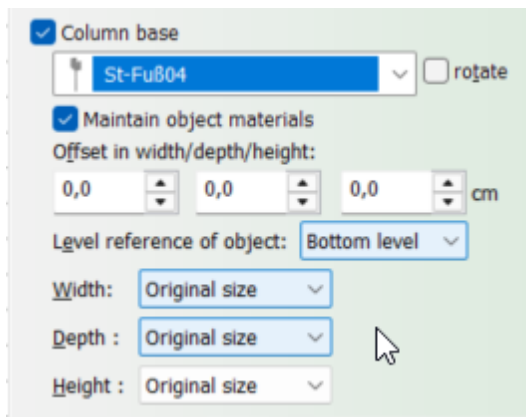

and the prop base is mounted directly on the prop:



You can proceed in the same way with the prop head.

#### 12.3.7.4 Contour/Fill/Hatching

These dialogs are used to define the 2D representation of the support. Further information on the [Contour](#)<sup>[138]</sup>, [Fill](#)<sup>[140]</sup> and [Hatching](#)<sup>[141]</sup> properties can be found in the [General properties dialogs](#)<sup>[134]</sup> chapter.

#### 12.3.7.5 Surface

In this dialog, you can define the material of the support in 3D mode. Further information can be found under [Surface](#)<sup>[145]</sup> in the *General properties dialogs* chapter.

If required, define different surface materials for the Shaft, Base and Capital:

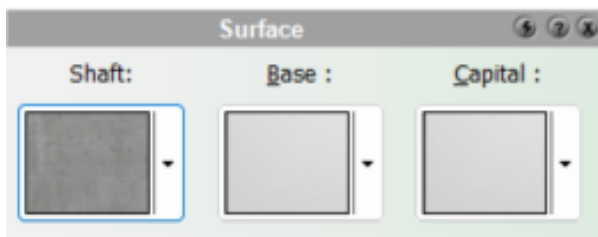

#### 12.3.7.6 Properties

Further information on the [properties](#)<sup>[145]</sup> can be found in the [General properties dialogs](#)<sup>[134]</sup> chapter.

#### 12.3.7.7 Layer/Floor

The layer and the storey of the column can be changed in this dialog. If you change the storey, the height of the column is also moved to the new storey. For more information, see [Layer/storey](#)<sup>[143]</sup> in the [General properties dialogs](#)<sup>[134]</sup> chapter.

### 12.3.7.8 Size/Position

The **Size/Position** form allows you to specify the size of the support, the rotation and the position in the planning alphanumerically. For more information, see [Size/Position](#)<sup>[143]</sup> in the [General properties dialogs](#)<sup>[134]</sup> chapter.

### 12.3.8 Influence on other components

#### Rooms

Supports have an influence on the area and volume calculation of rooms. Please note the required minimum size under **Options|Room info**.

#### Walls

Columns are not automatically intersected with walls

If columns are to be positioned in walls, please note the following for correct display:

- position the support in the desired position
- the support should be shown filled (white if necessary)
- if the column is covered by the wall (the wall was only drawn after the column), rearrange the display sequence (select column, **Edit|Order|In the foreground**).

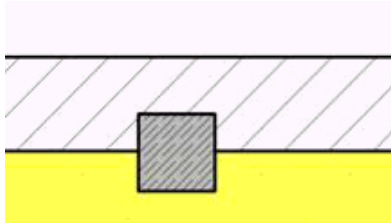

## 12.4 Beams

### 12.4.1 General information

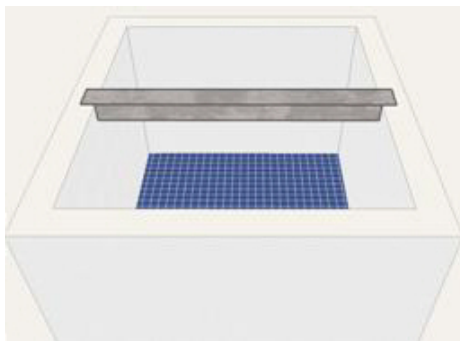

Beams are drawn in construction mode. They are placed by entering two points. A rectangle is created in the plan view, the contour, filling and hatching of which can be adjusted for the display. In the 3D model, a cuboid (rectangular cross-section) is created, the surface of which is selected separately for the top, sides and bottom. Beams are located on the **Beams** layer. However, this assignment can be subsequently changed in the **Layer/floor** dialog if required. Overhangs are also constructed using this function. The height can be adjusted in the **Beam** properties dialog.

### 12.4.2 Draw downstand beam

Clickon the **downstand beam** button in **Construction** mode.

**Input type:**

This selection bar lists the options for placing one or more downstand beams:

- **Draw a single downstand beam** 

You set the start point and the end point of the downstand beam in the planning. The downstand beam is created. If required, you can continue with the starting point of the next downstand beam.
- **Draw connected joists** 

You set the start point and the end point of the first joist. The end point of the predecessor is used as the start point for all further joists. End the entry with **[Esc]**. To cancel the action during input, select **Cancel function** from the context menu.
- **Draw in angled downstand beam** 

Select this input type and specify the angle in the input options. Then move the mouse pointer over any element in the drawing. The axis is displayed. Click on the desired position; the start and end points of the downstand beam are now placed on this axis.
- **Draw vertical downstand beam** 

Works in exactly the same way as the *Angled* downstand beam input type, but the new downstand beam is always perpendicular to the reference edge.
- **Draw in central downstand beam** 

You click on two input points between which the downstand beam is drawn in perpendicular to them in a specific division ratio. An auxiliary line is displayed on which the reference axis of the downstand beam will lie; set the start and end points of the downstand beam. You can specify the value for the division ratio in the input options.
- **Draw in parallel downstand beam** 

Places a downstand beam parallel to an already drawn element at a fixed distance.

  1. Select the edge to which the downstand beam should be parallel.
  2. Then enter the value for the desired distance.
  3. Click on the side of the edge on which the downstand beam should lie.
  4. Determine the position of the start and end points.

### 12.4.3 The input bar

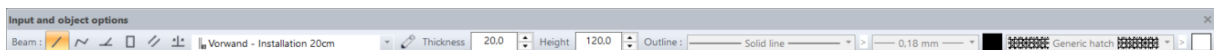

The type of joist, thickness, height and filling are set in the input bar.

### 12.4.4 Property dialogs

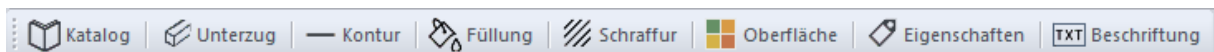

#### 12.4.4.1 Catalogue

Subtracts that are used frequently are stored in the catalog. Further information on [catalogs](#)<sup>150</sup> can be found in the [General properties dialogs](#)<sup>134</sup> chapter.

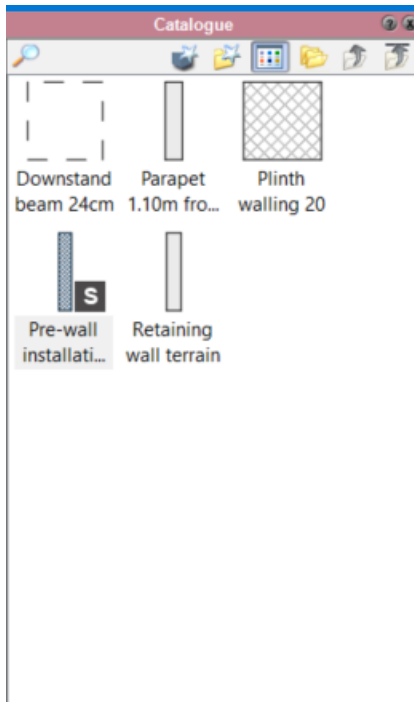

#### 12.4.4.2 Downstand beam

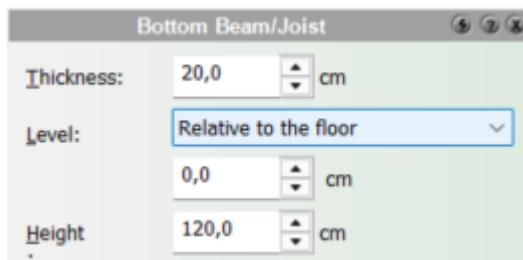

The dimensions and level of the joist and the reference constant can be defined in this dialog:

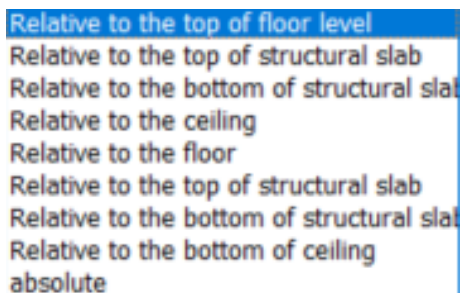

#### Options:

Thickness: cm

Level:

relative to the top of floor level

relative to the top of structural slab

relative to the bottom of structural slab

relative to the ceiling  
relative to the floor  
relative to the top of structural slab  
relative to the bottom of structural slab  
relative to the bottom of ceiling  
absolute  
cm  
Height: cm  
Constant wall axis

#### 12.4.4.3 Contour/Fill/Hatching

These dialogs are used to define the 2D representation of the downstand beam. Further information on the [Contour](#)<sup>[138]</sup>, [Fill](#)<sup>[140]</sup> and [Hatching](#)<sup>[141]</sup> properties can be found in the [General properties dialogs](#)<sup>[134]</sup> chapter.

#### 12.4.4.4 Surface

In this dialog, you can specify the material of the downstand beam in 3D mode. You can find more information on [the surface](#)<sup>[145]</sup> in the [General properties dialogs](#)<sup>[134]</sup> chapter.

#### 12.4.4.5 Properties

Further information on the [properties](#)<sup>[145]</sup> can be found in the [General properties dialogs](#)<sup>[134]</sup> chapter.

#### 12.4.4.6 Masses

Further information on the *masses* can be found in the [General properties dialogs](#)<sup>[134]</sup> chapter.

#### 12.4.4.7 Position number (PosNr)

Further information on the position [number](#)<sup>[147]</sup> can be found in the [General properties dialogs](#)<sup>[134]</sup> chapter.

#### 12.4.4.8 Layer/Floor

In this dialog, the layer and storey of the downstand beam can be changed. If you change the storey, the height of the downstand beam is also moved to the new storey. For more information, see [Layer/storey](#)<sup>[143]</sup> in the [General properties dialogs](#)<sup>[134]</sup> chapter.

#### 12.4.4.9 Size/Position

The *Size/Position* form allows you to specify the size of the downstand beam, the rotation and the position in the planning alphanumerically. For more information, see [Size/Position](#)<sup>[143]</sup> in the [General properties dialogs](#)<sup>[134]</sup> chapter.

## 12.5 Profiled Beams

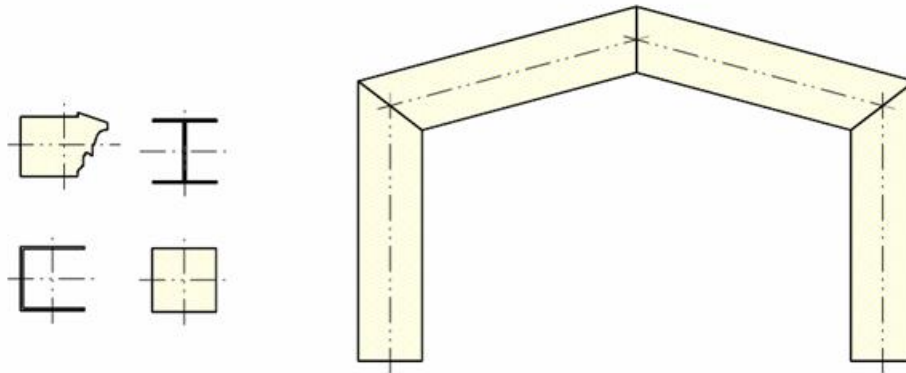

### 12.5.1 General information

The **free beam** complements the column and joist elements with its extensive functions.

The most important properties of the beam are

- the cross-section can be rectangular, round or polygonal.
- the cross-sectional dimensions at the start and end can differ (conical beam).
- the height of the start and end points can be different.
- Beams can be trimmed to each other, to walls, to lines, etc.
- The beam can display its longitudinal axis and the cross-sectional axes.
- The 2D representation of the beam refers to the set cutting height, the cutting surface can be hatched.

Application examples for the free beam could be

- Steel structures
- Roof and window cornices
- Wooden structures (balconies, carports, ...)
- skirting boards
- and much more

### 12.5.2 Draw bars

Clickon the **Profiled beam** button  in **Construction** mode.

#### Catalog for component templates

The easiest way to define all the parameters of the new beam is to select a corresponding component template from the catalog. To do this, open the catalog and click on the relevant template.

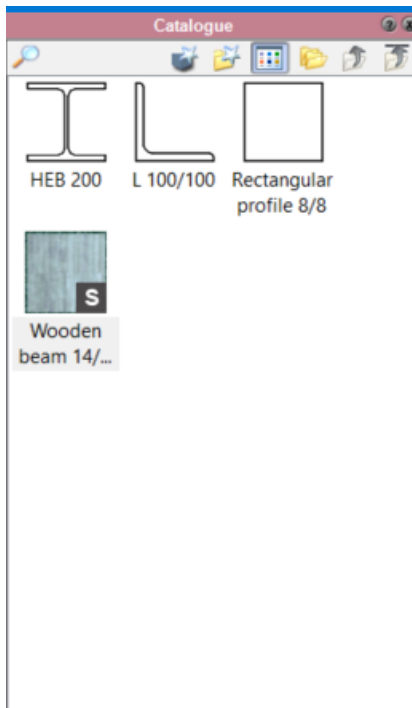



All values of the template are adopted and the bar can be placed in the drawing. Of course, all parameters can also be changed after assigning a template. Further information can be found in the [General properties dialogs](#) <sup>[134]</sup> chapter.

### 12.5.2.1 Input types

- **Bar (vertical)** 

The bar is displayed with its cross-section already at the cursor. Press **W** until the desired reference point on the beam cross-section is used. Now position this point in the planning; either freely by snapping to an existing point or by entering coordinates.
- **Beam (horizontal)** 

You set the start point and the end point of the beam in the planning.



 Possible input options: Offset - the beam is constructed parallel to the input points with offset.
- **Beam (open/closed polygon)**  

Required input: n points  
 The bar is entered using any number of corner points. End the input with **[Esc]**.  
 To cancel the action during input, select **Cancel function** from the context menu.

 Possible input options: Offset - the bar is constructed parallel to the input points with an offset.

- **Bar (rectangle)** 

Required input: 2 points  
The bar is entered via two diagonally opposite corner points.

 Possible input options: Offset - the bar is constructed parallel to the input points with offset.
- **Bar (rotated rectangle)** 

Required input: 3 points  
First define one side of the rectangle with two points. The height of the rectangle is defined with the third point.

 Possible input options: Offset - the bar is constructed parallel to the input points with offset.

### 12.5.3 The input bar

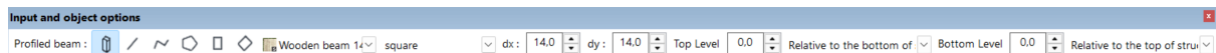

The bar type, the type of bar, the spacing and the alignment are set in the input bar.

### 12.5.4 Property dialogs

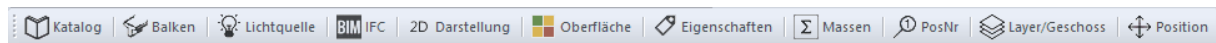

#### 12.5.4.1 Catalogue

Bars that are used frequently are stored in the catalog. Further information on [catalogs](#)<sup>[150]</sup> can be found in the [General properties dialogs](#)<sup>[134]</sup> chapter.

#### 12.5.4.2 Light source

Further information on the [light source](#)<sup>[148]</sup> can be found in the [General properties dialogs](#)<sup>[134]</sup> chapter.

#### 12.5.4.3 Beams

## 12.5.4.3.1 Cross section

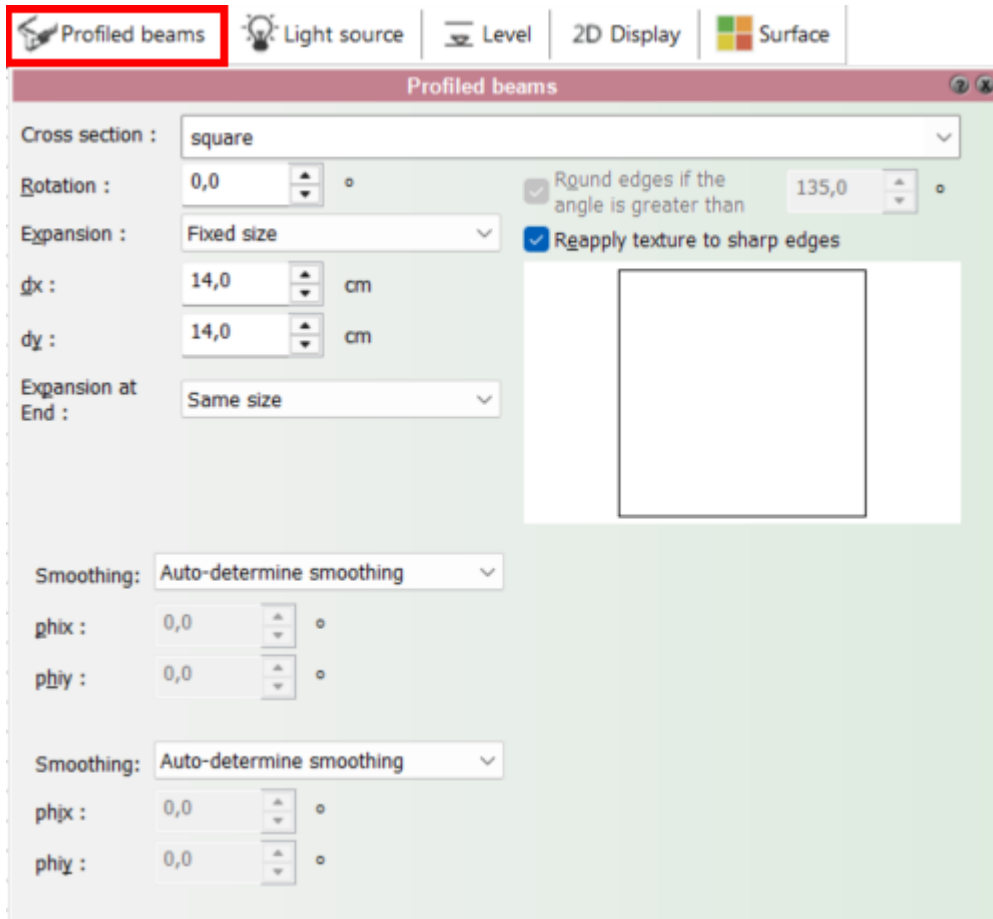

**Cross-section:** The rectangular and round shapes are always available as cross-sections. Free profiles can be drawn as 2D cross-sections. All symbols from the Beam cross-sections directory are displayed.

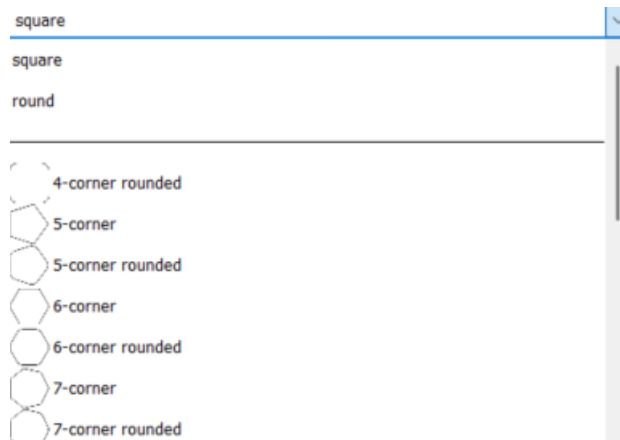

Another symbol can be selected at the very end of the selection list using the **Browse** command.

A separate 2D symbol as a beam cross-section is drawn from any 2D elements (lines, arcs, polygons, etc.) in the correct dimensions and saved as a symbol. The contour must be closed. The symbol only appears in the selection list after the next start of Plan7Architect; it can be selected immediately with the **Browse** command.

**Rotation:** Use this value to define the rotation of the profile around the longitudinal axis of the bar.

**Extension:** Specifies the size of the bar profile. The following options are available:

- **Fixed size:** dx and dx determine the width and height of the bar.
- **Original size:** The bar is drawn as large as the underlying 2D profile.
- **Absolute surcharge:** You can enter positive and negative deviations in centimetres from the original dimensions of the profile.
- **Relative surcharge:** You can enter deviations from the original dimensions of the profile in percentage values.
- **Extension at end:** Determines the size of the cross-section at the end of the beam (point 2). The same input options are available as for the start point, but you also have the option of adopting the cross-section dimensions from the start point (same size).

**Round off edges:** The 3D display can optionally be rounded from the set angle. The texture in 3D mode can be reapplied to edges with an angle of  $\leq 90$  degrees. The texture then does not run seamlessly around this edge. This may be necessary when displaying wood grains or similar.

#### 12.5.4.3.2 Draw cross section yourself

Any beam cross-section can be drawn and stored in a catalog.

1. create the cross-section in the construction view using 2D functions



2. select this template completely and store it in the symbol catalog  under beam cross-section

  
 Profiled  
 beam cro...

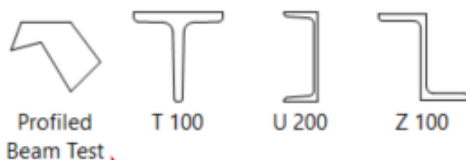

3 .select the construction element **Profiled beams** element  and select the corresponding cross-section under Beam:

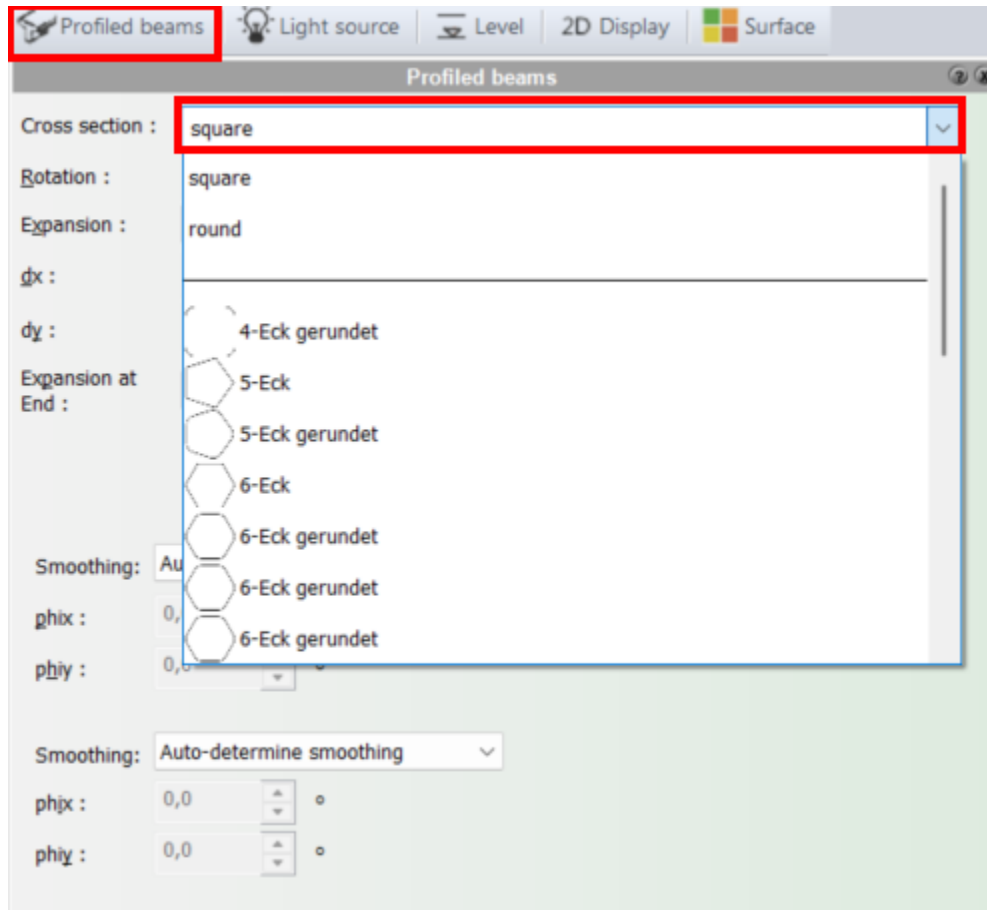

The created beam should then be visible in the drop down list.

## 12.5.4.3.3 Beam/Honoring

**Mitre:** The angles of the end faces of the beam are defined in this dialog.

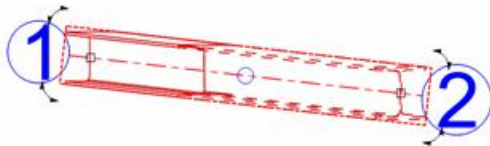
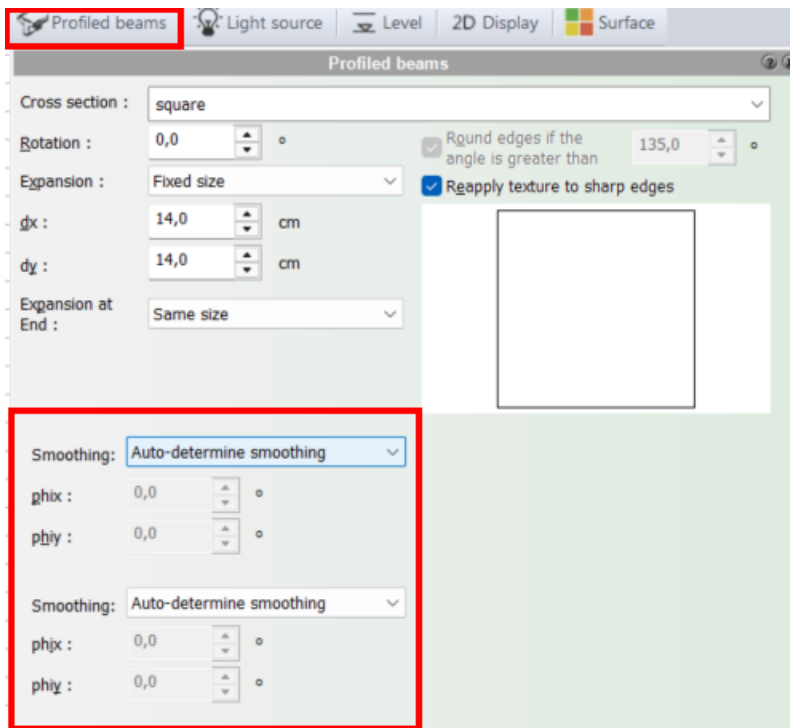

In the form, the upper settings apply to point 1 and the lower values to point 2 of the beam. The points are labeled during selection. If the beam is vertical, the lower point is point 1.

- **Determine mitre automatically:** The angle of the end face is calculated automatically. With a free end, the surface is orthogonal; if the beam is trimmed with another element, the angle is adjusted accordingly.
- **No mit er:** The end face is always orthogonal
- **Fixed miter:** You can use the  $phix$  and  $phiy$  values to define the inclination.

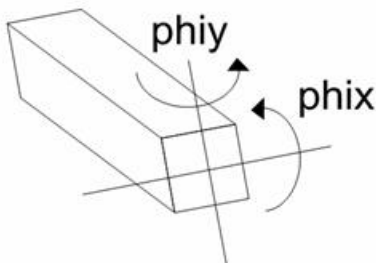

$Phix$  tilts the end face,  $phiy$  rotates the end face.

## 12.5.4.4 2D representation

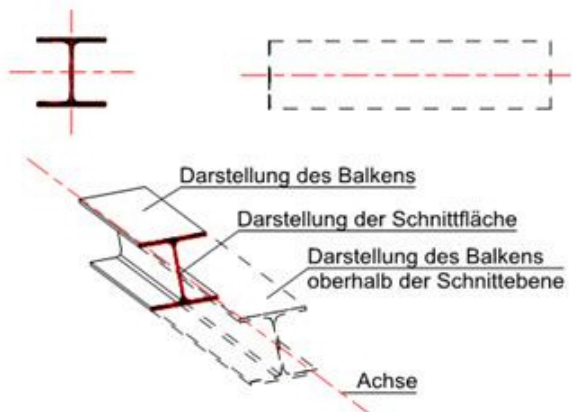
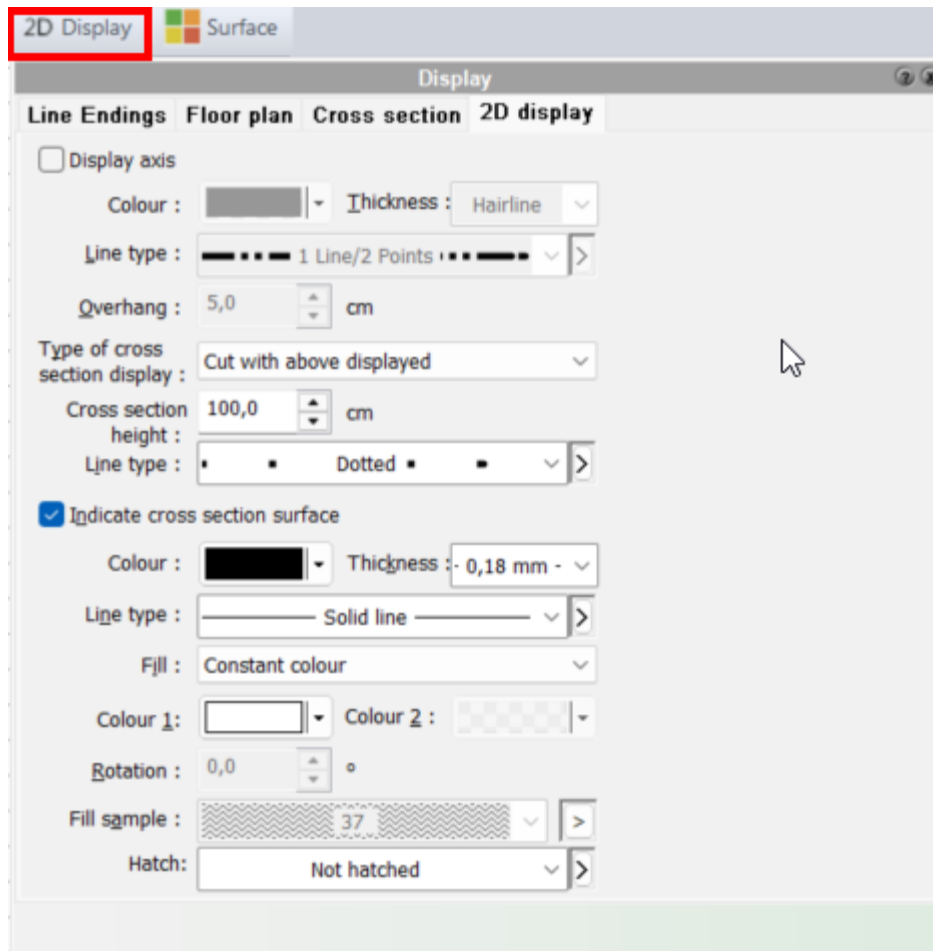

The 2D representation of a beam consists of four parts:

1. the representation of the beam below the section plane
2. the representation of the beam above the section plane
3. the section plane
4. the axis

Basically, you choose whether the bar is displayed cut or not. The section height (measured from the upper floor edge of the storey) can be set.

The display of the beam (1) is recorded in the [Contour](#)<sup>[138]</sup> tab.

#### 12.5.4.5 Surface

In this dialog, you can define the material of the bar in 3D mode. You can find more information on [the surface](#)<sup>[145]</sup> in the [General properties dialogs](#)<sup>[134]</sup> chapter.

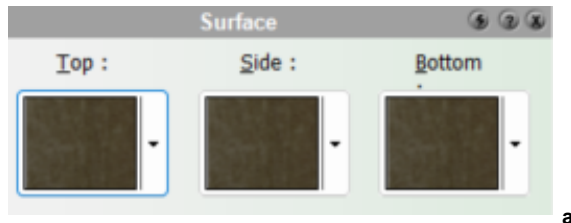

#### 12.5.4.6 Properties

Further information on the [properties](#)<sup>[145]</sup> can be found in the [General properties dialogs](#)<sup>[134]</sup> chapter.

#### 12.5.4.7 Masses

Further information on the *masses* can be found in the [General properties dialogs](#)<sup>[134]</sup> chapter.

#### 12.5.4.8 Level

This dialog is only available during input. When entering a vertical bar, select the reference plane and the value of the deviation for the lower and upper edge of the bar.

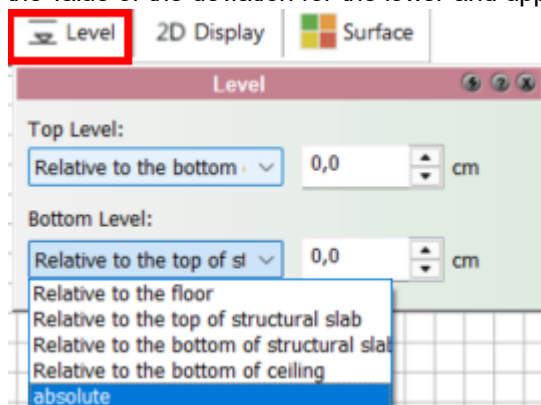

For horizontal bars, enter the height of the axis.

#### 12.5.4.9 Position number (PosNr)

Further information on the position number can be found in the [General properties dialogs](#) chapter.

#### 12.5.4.10 Layer/Floor

In this dialog, the layer and the storey of the bar can be changed. If you change the storey, the height of the bar is also moved to the new storey. For more information, see [Layer/storey](#)<sup>[143]</sup> in the [General properties dialogs](#)<sup>[134]</sup> chapter.

#### 12.5.4.11 Position

This dialog is not available during input; it is relevant for subsequent adjustments to bars that have already been placed.

↔ Position

Position

Orientation : Horizontal

Level: 73,0 cm      Length : 1192,968 cm

Rotation and angle

Z-Axis                  Qwn Axis

-90,0 °      0,0 °

End point coordinates

	(1)	(2)
x (Width) :	<span style="border: 1px solid gray; padding: 2px;">-2241,41</span> cm	<span style="border: 1px solid gray; padding: 2px;">-2241,41</span> cm
y (Depth) :	<span style="border: 1px solid gray; padding: 2px;">5992,969</span> cm	<span style="border: 1px solid gray; padding: 2px;">4800,0</span> cm
z (Height) :	<span style="border: 1px solid gray; padding: 2px;">80,0</span> cm	<span style="border: 1px solid gray; padding: 2px;">80,0</span> cm
Type of level :	<span style="border: 1px solid gray; padding: 2px;">absolute</span>	<span style="border: 1px solid gray; padding: 2px;">absolute</span>
Position in surface :	<span style="border: 1px solid gray; padding: 2px;">Midpoint</span>	<span style="border: 1px solid gray; padding: 2px;">Midpoint</span>
<input checked="" type="checkbox"/> Hold length constant when changing some end points		
Reference point coordinates:	x (Width) : <span style="border: 1px solid gray; padding: 2px;">-2241,41</span> cm	y (Depth) : <span style="border: 1px solid gray; padding: 2px;">5396,484</span> cm
		z (Height) : <span style="border: 1px solid gray; padding: 2px;">80,0</span> cm

Depending on the selected orientation, not all input values are always available for selection. The orientation of the bar also changes when the values are changed.

Three rotation angles determine the position of the bar in space:

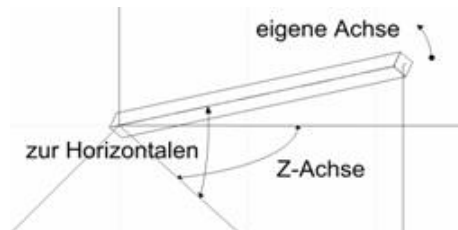

The angle to the Z-axis is the orientation in the floor plan.

The option Keep (X/Y) and only change z is only available for any beam and for unfixed lengths. Select this option to change the inclination of a beam but leave the X/Y values unchanged.

The coordinates of the end points (1. and 2.) show the values in relation to the reference plane selected under Level type. The point in the cover surface can also be changed for this coordinate determination.

## 12.6 Ceiling

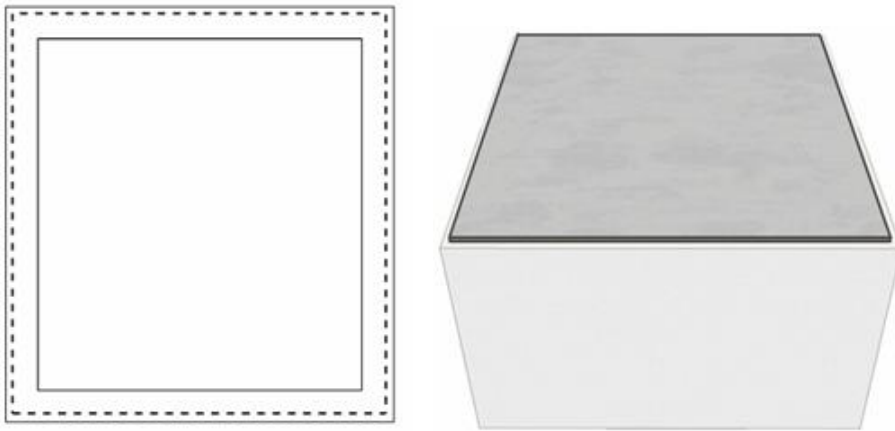

### 12.6.1 General information

In Plan7Architect, a **ceiling** is a horizontal component that closes off a room or building at the top. A ceiling on the first floor is therefore located between the ground floor and the second floor.

There are two different ways to draw ceilings in the project:

- **the automatically generated storey ceiling**
- **the ceilingcomponent**

#### **Automatically generated storey ceilings vs. individual ceilings**

To simplify input, a storey ceiling is automatically drawn along the outer contour of the floor plan as soon as at least one room has been created on the storey. The height of the automatic storey ceiling is always determined by the parameters of the storey for

**$\text{Room height} + \text{ceiling cladding} = \text{lower edge of the ceiling}$**  and the **ceiling thickness**.

The height of the storey ceiling can only be changed via the storey parameters. This automatically generated storey ceiling can be switched off at any time.

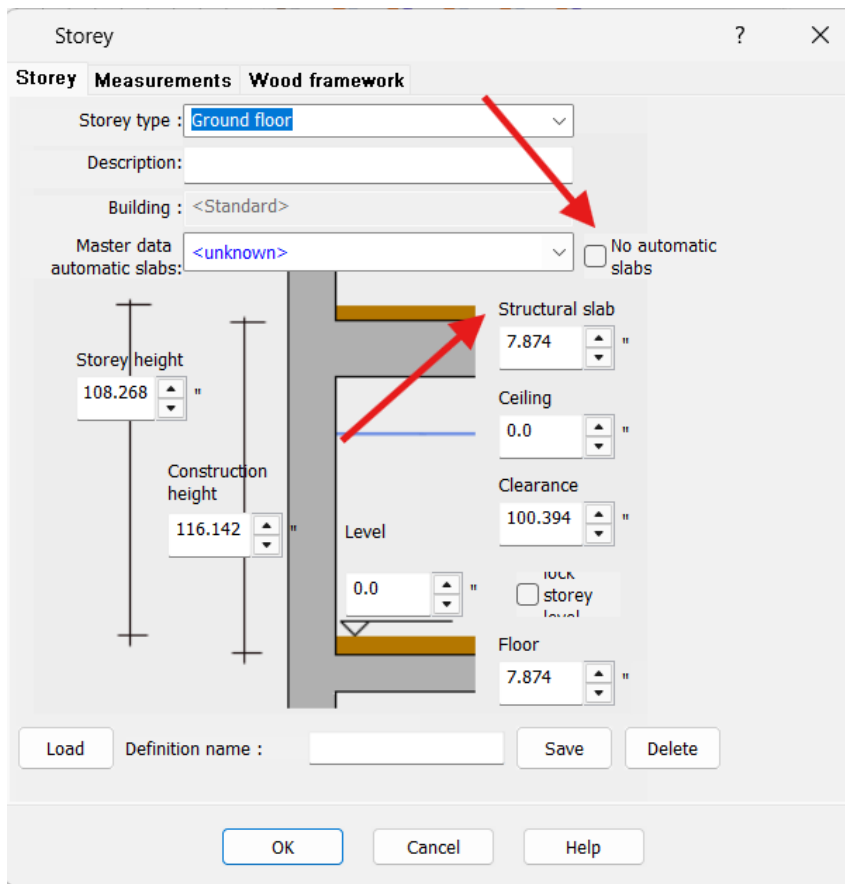

The **ceiling** component , on the other hand, allows you to enter ceiling slabs with a **free contour** and **height**.

If a free ceiling is now entered in a storey, the automatically generated storey ceiling is omitted at this point.

Ceilings are therefore independent of the contour of the external walls; the height and ceiling thickness can be freely set.

Further information on the parameters of storey ceilings can be found in the **Storeys** chapter.

## 12.6.2 Drawing

Ceiling tiles are stored on the **Ceiling tiles** layer.

### 12.6.2.1 Input types

The various options for placing ceilings are listed in the selection bar.

- **Polygon** 

Required input: n points  
 The ceiling is entered using any number of corner points. End the input by selecting **[Esc]** or via the context menu **Finish element**. Ceiling polygons are always closed.

 Possible input options: **Offset** - the ceiling is constructed parallel to the input points with offset.

- **Polygon with fixed width** 

Required input: n points.  
The ceiling is entered using any number of corner points. The result is a "band" of the set width with a closed contour. End the input by selecting **[Esc]** or via the context menu **Finish element**.

+ Possible input options:  
**Offset** - the ceiling is constructed parallel to the input points with offset.  
**Width** - the width of the polygon.
- **Rectangle** 

Required input: 2 points  
The ceiling is entered via two diagonally opposite corner points.

+ Possible input options: **Offset** - the ceiling is constructed parallel to the input points with offset.
- **Rotated rectangle** 

Required input: 3 points  
First define one side of the rectangle with two points. The height of the rectangle is defined with the third point.

+ Possible input options: **Offset** - the ceiling is constructed parallel to the input points with offset.
- **Spline** 

Required input: n points  
The ceiling is drawn as a spline with any number of corner points. End the input by selecting **[Esc]** or via the context menu **Finish element**.

+ Possible input options: **Offset** - the ceiling is constructed parallel to the input points with offset.

### 12.6.3 The overview bar

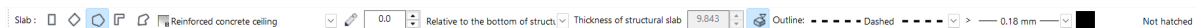

The ceiling type, alignment, ceiling structure, contour, infill and hatching are set in the overview bar.

### 12.6.4 Property dialogs

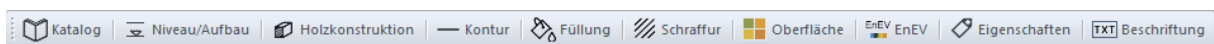

#### 12.6.4.1 Catalogue

Component templates are offered in the catalog. If you select a component template, all parameters of the ceiling are adjusted. Further information on [catalogs](#)<sup>150</sup> can be found in the [General properties dialogs](#)<sup>134</sup> chapter.

#### 12.6.4.2 Level/Structure

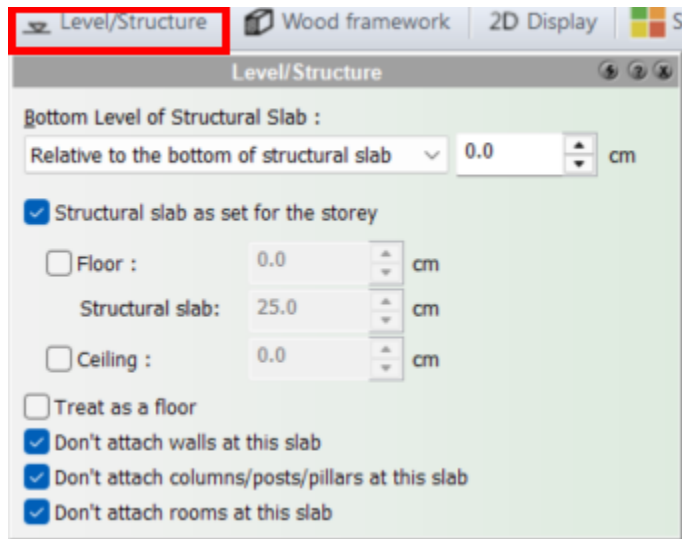

The height of ceiling tiles normally depends on the storey and its height. Settings that deviate from this can be made in this dialog.

The level of the lower edge of the ceiling can refer to all available storey levels. The additional value can be entered as an offset to this reference level.

The ceiling structure, i.e. the thickness of the bare ceiling, can also be set independently of the storey. For special cases (such as balcony slabs), a floor and a suspension can also be set. Floors and suspensions can otherwise only be set for rooms.

#### 12.6.4.3 Wooden Construction

12.6.4.3.1 General

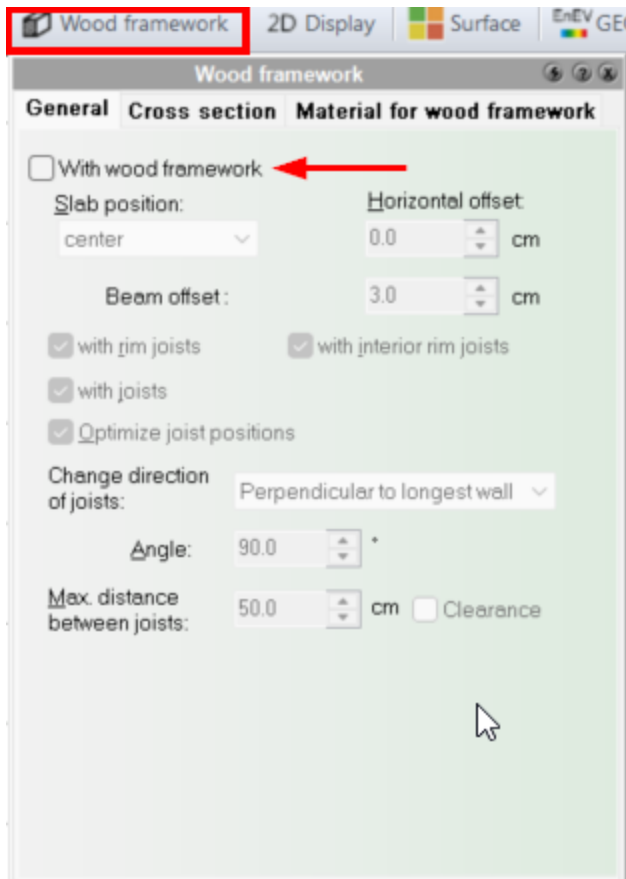

The timber construction is switched on with the **With timber construction** radio button. (Please note that either **Display** or **Exclusive** must be selected for the display of all timber constructions in **View Timber construction** (bottom edge of screen).

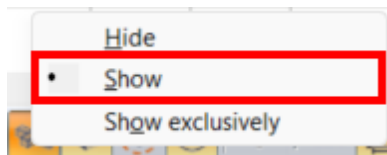

The selection **Position in the ceiling** determines the height of the construction in the ceiling.

- **Center** means that the axes of the wooden beams are centered in the ceiling.
- **Inside** means that the axis of the beams is exactly at the height of the lower edge of the ceiling
- **Outside** analogous to the top side.

The **internal offset** is the distance between the wooden beams and the outer contour of the storey ceiling or the contour of the ceiling opening. Which beams are constructed is set using the **Edge beams**, **Inner edge beams** and **beams** radio buttons. Inner edge beams are created along ceiling openings.

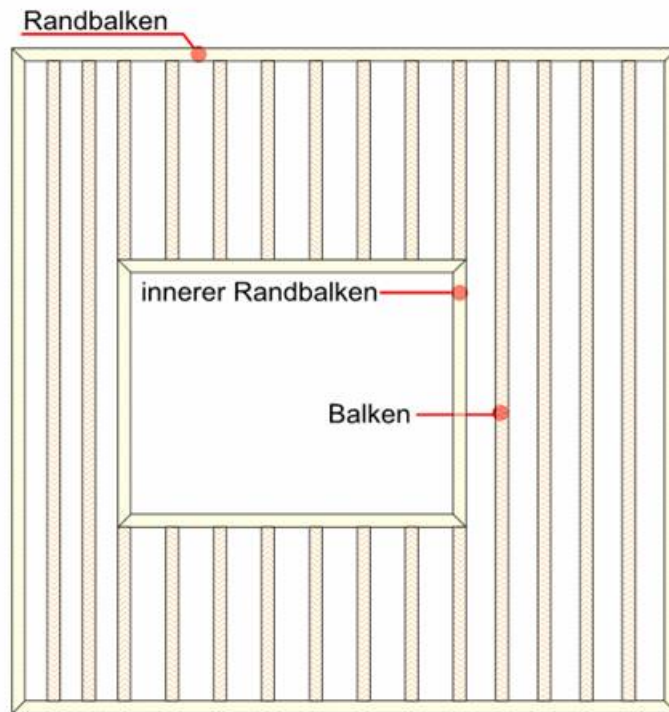

The laying direction of the beams can be defined with:

- **as longest wall** - The beams are created parallel to the longest contour edge.
- **perpendicular to the longest wall** - The beams are created perpendicular to the longest contour edge.
- **Angle** - Specify the angle as a numerical value.

The distance between the beams can be entered with the value **max. distance** between the beams. Optionally, the clear dimension between the beams can also be entered. However, the timber construction is automatically determined so that the corner points of ceiling openings - or the inner edge beams created there - are flush with the beams.

#### 12.6.4.3.2 Cross sections

You define the cross-sections of the wooden beams in the **Cross-sections** tab. If the **plus superstructure thickness** option is activated, the thickness of the floor slab is added to the thickness of the beams. The value - 5.0 cm means that the beam is drawn 5.0 cm lower than the ceiling.



## 12.6.4.3.3 Material for timber construction

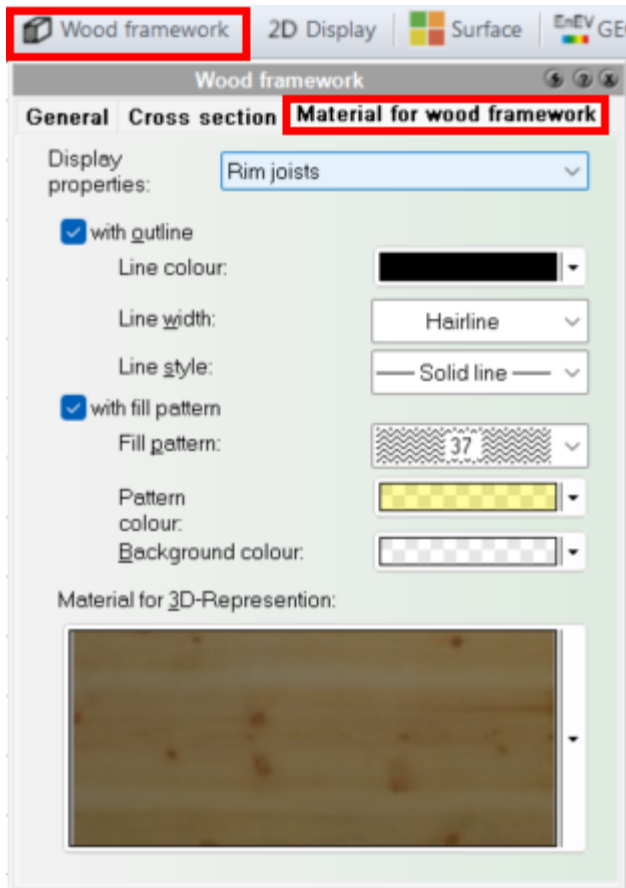

You specify the material for the timber construction in the **Material for timber construction** tab.

Under **Display property for:** in the drop-down menu, select the component for which you want to adjust the display:

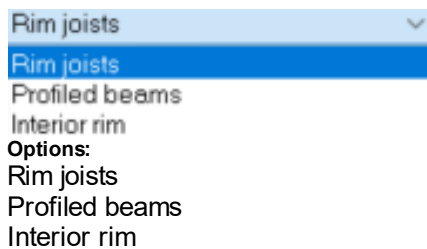

Assign a **contour/pattern** for the 2D display and a **material for the 3D display**.

## 12.6.4.4 Contour/Fill/Hatching

For more information on the [layer/floor](#)<sup>[143]</sup>, [size/position](#)<sup>[143]</sup>, [contour](#)<sup>[138]</sup>, [fill](#)<sup>[140]</sup> and [hatching](#)<sup>[141]</sup>, [surface](#)<sup>[145]</sup>, **dimensions** and properties, please refer to the chapter [General properties dialogs](#)<sup>[134]</sup>.

## 12.6.4.5 Surface

Set the material for the top, bottom and side surfaces of the ceiling. Further information can be found [on the surface](#)<sup>[145]</sup> in the [General properties dialogs](#)<sup>[134]</sup> chapter.

#### 12.6.4.6 Properties

For more information on the [layer/floor](#)<sup>[143]</sup>, [size/position](#)<sup>[143]</sup>, [contour](#)<sup>[138]</sup>, [fill](#)<sup>[140]</sup> and [hatching](#)<sup>[141]</sup>, [surface](#)<sup>[145]</sup>, **dimensions** and properties, please refer to the chapter [General properties dialogs](#)<sup>[134]</sup>.

#### 12.6.4.7 Masses

For more information on the [layer/floor](#)<sup>[143]</sup>, [size/position](#)<sup>[143]</sup>, [contour](#)<sup>[138]</sup>, [fill](#)<sup>[140]</sup> and [hatching](#)<sup>[141]</sup>, [surface](#)<sup>[145]</sup>, **dimensions** and properties, please refer to the chapter [General properties dialogs](#)<sup>[134]</sup>.

#### 12.6.4.8 Layer/Floor

For more information on the [layer/floor](#)<sup>[143]</sup>, [size/position](#)<sup>[143]</sup>, [contour](#)<sup>[138]</sup>, [fill](#)<sup>[140]</sup> and [hatching](#)<sup>[141]</sup>, [surface](#)<sup>[145]</sup>, **dimensions** and properties, please refer to the chapter [General properties dialogs](#)<sup>[134]</sup>.

#### 12.6.4.9 Size/Position

For more information on the [layer/floor](#)<sup>[143]</sup>, [size/position](#)<sup>[143]</sup>, [contour](#)<sup>[138]</sup>, [fill](#)<sup>[140]</sup> and [hatching](#)<sup>[141]</sup>, [surface](#)<sup>[145]</sup>, **dimensions** and properties, please refer to the chapter [General properties dialogs](#)<sup>[134]</sup>.

#### 12.6.4.10 Edit points

The functions in the Contour tools area can be used to insert additional points or delete points in a ceiling tile that has already been drawn.

You can move points by moving the mouse pointer over the corner point of the unselected ceiling and dragging the point to the new position while holding down the left mouse button. Note that the corner point is highlighted in red at the start of the move. This activates snap mode and the point can be placed precisely.

Note: In the **general input options**, the option *also move unselected elements with the mouse* must be activated.

## 12.7 Ceiling openings

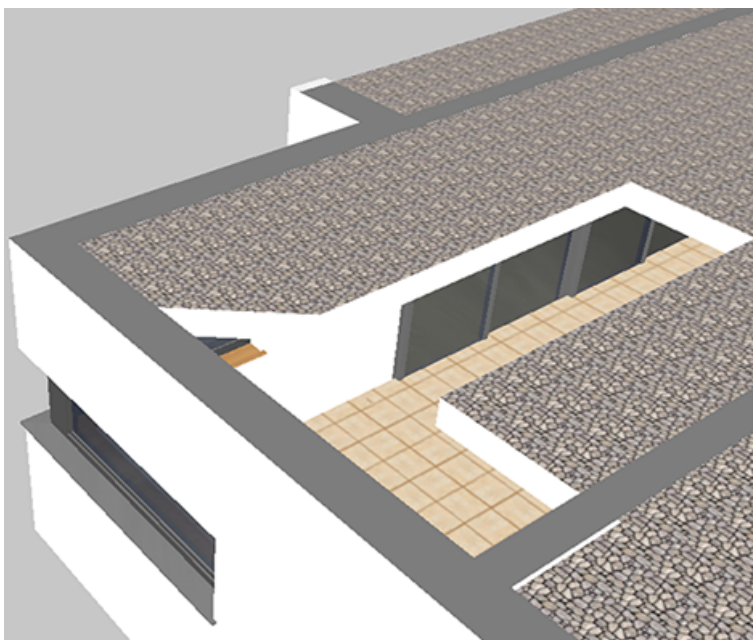

## 12.7.1 General information

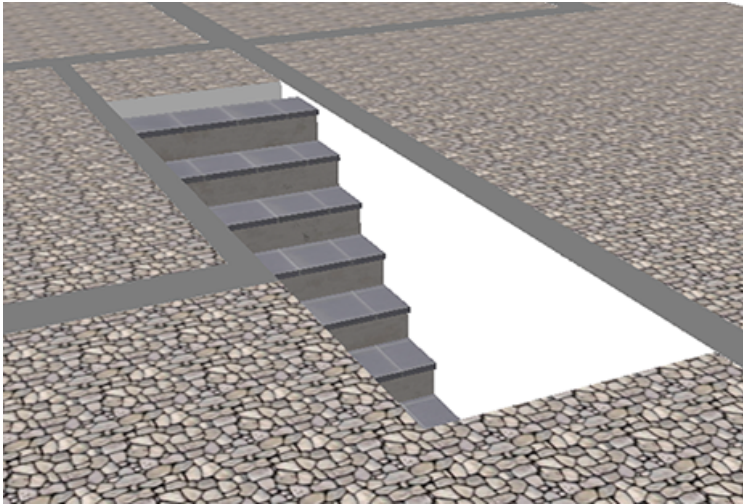

### Ceiling openings

Cut holes in ceiling panels and floor slabs. The timber construction of the ceiling is recessed and edge beams are laid along the opening contour.

If stairs are placed, ceiling openings are created automatically when the stairs are set down. These openings follow the contour of the staircase. For individual contours, the properties of the opening created with the staircase are eliminated and a conventional ceiling opening is constructed.

## 12.7.2 Drawing

Ceiling openings are placed on the layer *ceiling tiles*.

### More information under:

### 12.7.2.1 Input types

This selection bar lists the various options for placing ceiling openings/ceiling recesses.

- **Polygon** 

Required input: n points  
 The ceiling opening is entered using any number of corner points. End the input by selecting **[Esc]** or via the context menu **Finish element**. Ceiling opening polygons are always closed.

**+** Possible input options: **Offset** - the ceiling opening is constructed parallel to the input points with offset.
- **Polygon with fixed width** 

Required input: n points.  
 The ceiling opening is entered using any number of corner points. The result is a "band" of the set width with a closed contour. End the input by selecting **[Esc]** or via the context menu **Finish element**.

**+** Possible input options:  
**Offset** - the ceiling opening is constructed parallel to the input points with offset.  
**Width** - the width of the polygon.

- **Rectangle** 

Required input: 2 points  
The ceiling opening is entered via two diagonally opposite corner points.

+ Possible input options: **Offset** - the ceiling opening is constructed parallel to the input points with offset.
- **Rotated rectangle** 

Required input: 3 points  
First define one side of the rectangle with two points. The height of the rectangle is defined with the third point.

+ Possible input options: **Offset** - the ceiling opening is constructed parallel to the input points with offset.
- **Spline** 

Required input: n points  
The ceiling opening is drawn as a spline with any number of corner points. End the input by selecting [**Esc**] or via the context menu **Finish element**.

+ Possible input options: **Offset** - the ceiling opening is constructed parallel to the input points with offset.

### 12.7.3 The overview bar



The type of ceiling opening, contour, filling and hatching are set in the overview bar.

### 12.7.4 Property dialogs

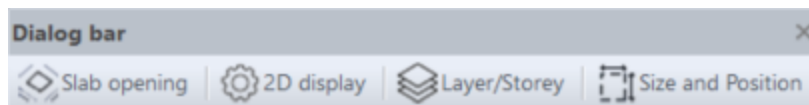



The [Layer/floor](#)<sup>143</sup>, [Size and position](#)<sup>143</sup>, [Contour](#)<sup>138</sup>, [Fill](#)<sup>140</sup> and [Hatch](#)<sup>141</sup> properties dialogs are explained in the [General properties dialogs](#)<sup>134</sup> chapter.

#### 12.7.4.1 Ceiling opening

This option can be used to set the ceiling opening to be displayed on the floor above. This property is active by default.

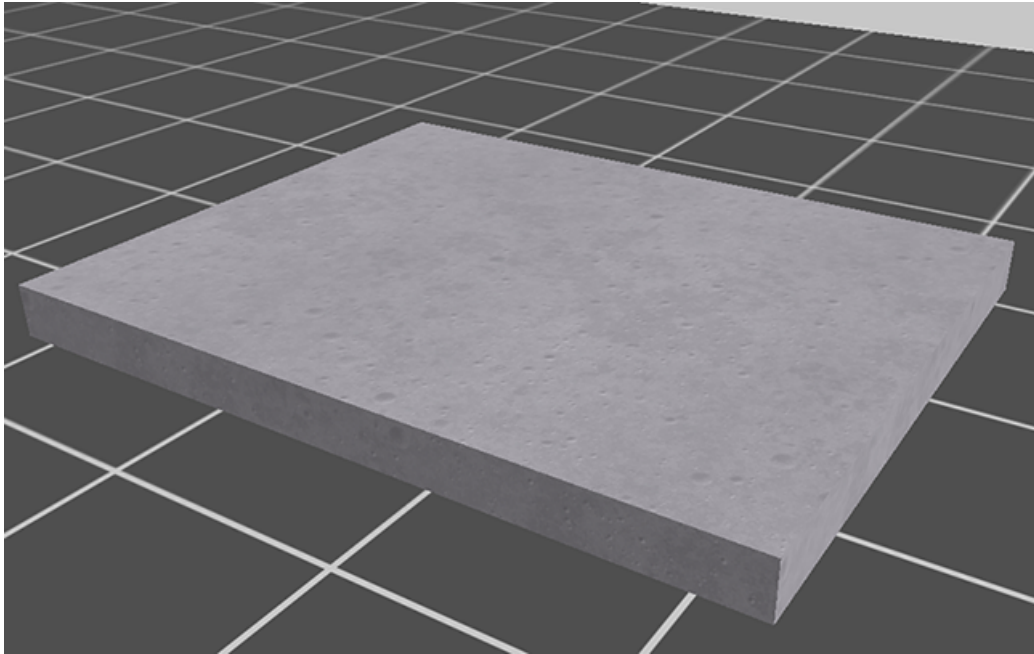
## 12.8 Plates



The following principles must be observed when working with **panels**  :  
Panels must lie in one plane (ground plan or construction plane). The base and cover surfaces are always parallel to each other.

There are four different applications:

**1. slab**

The panel is not influenced by other components.

**2. panel blended**

Is intersected with other panels of this type and recesses.

**3. recess**

Recesses are cut out by cut panels.

**4. material areas**

Are used to display areas with other materials in wall segments or room floor surfaces. The original 3D surface is cut out in the process.

### 12.8.1 Drawing

Panels are stored on the **Panels** layer. However, assignment to another layer is possible at any time in the **Layer/floor** properties dialog.

#### 12.8.1.1 Input types

The various options for placing panels are listed in the selection bar.

- **Polygon** 

Required input: n points

The slab is entered using any number of corner points. End the input by selecting **[Esc]** or via the context menu **Finish element**. Slab polygons are always closed.

+ Possible input options: Offset - the slab is constructed parallel to the input points with offset.

- **Polygon with fixed width** 

Required input: n points.  
The slab is entered using any number of corner points. The result is a "band" of the set width with a closed contour. End the input by selecting **[Esc]** or via the context menu **Finish element**.

+ Possible input options:  
Offset - the slab is constructed parallel to the input points with offset.  
Width - the width of the polygon.

- **Rectangle** 

Required input: 2 points  
The slab is entered via two diagonally opposite corner points.

+ Possible input options: Offset - the slab is constructed parallel to the input points with offset.

- **Rotated rectangle** 

Required input: 3 points  
First define one side of the rectangle with two points. The height of the rectangle is defined with the third point.

+ Possible input options: Offset - the slab is constructed parallel to the input points with offset.

- **Spline** 

Required input: n points  
The slab is drawn as a spline with any number of corner points. End the input by selecting **[Esc]** or via the context menu **Finish element**.

+ Possible input options: Offset - the slab is constructed parallel to the input points with offset.

## 12.8.2 Property dialogs

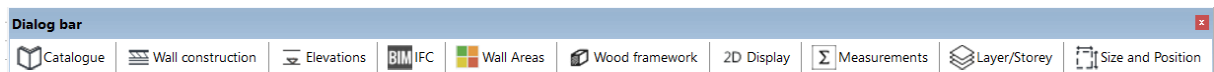

### 12.8.2.1 Catalogue

Component templates are offered in the catalog. If you select a component template, all parameters of the panel are adjusted. Further information on [catalogs](#)<sup>[150]</sup> can be found in the [General properties dialogs](#)<sup>[134]</sup> chapter.

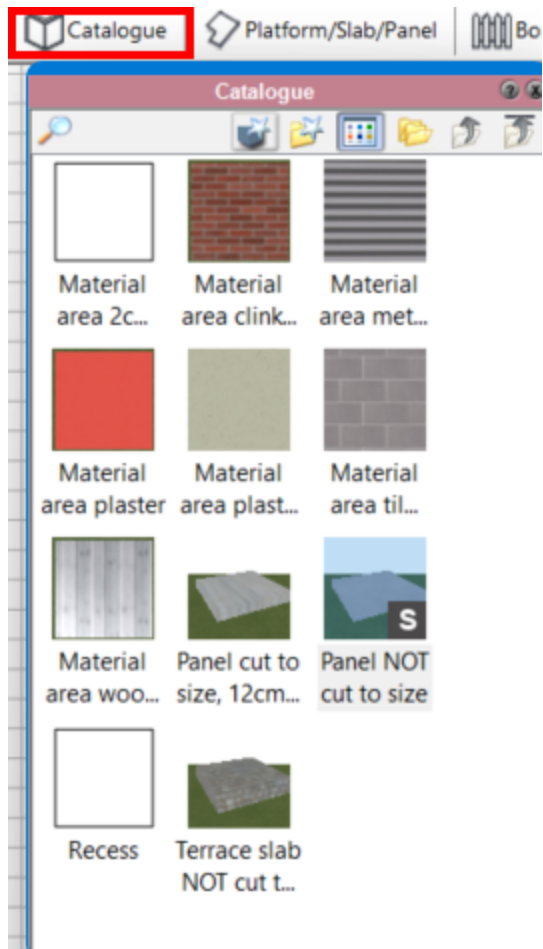

### 12.8.2.2 Plate

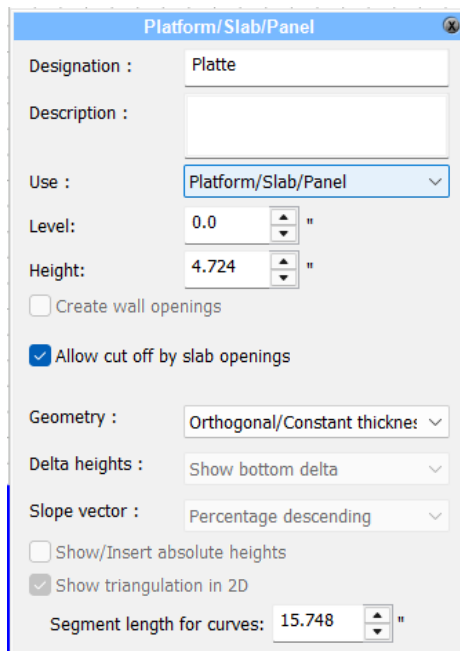

**Use:** Select from the four options whether the panel should be drawn as a slab, cut slab, recess or material area.

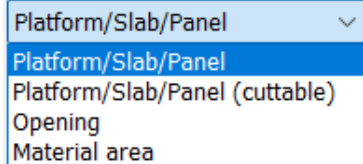

**Geometry:** Select the geometry of the slab from the three options orthogonal/constant thickness, inclined/constant thickness and inclined/variable thickness.

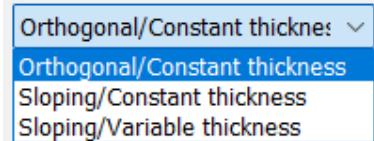

**Inclined slabs** can also be given a slope, whereby the **delta heights** can be displayed here, with the four display options: Show Lower, Show Upper, Show All, Show None.

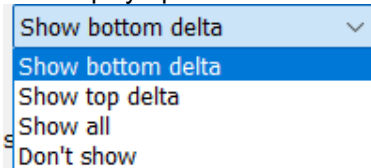

The **incline/decline** of the inclined slab can be displayed either in **degrees** or as a **percentage**.

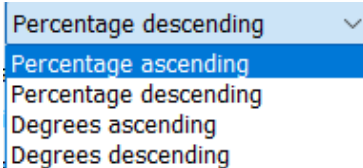

In addition, the **absolute heights** can be displayed/entered and a **decomposition into triangles in 2D** can also be displayed.

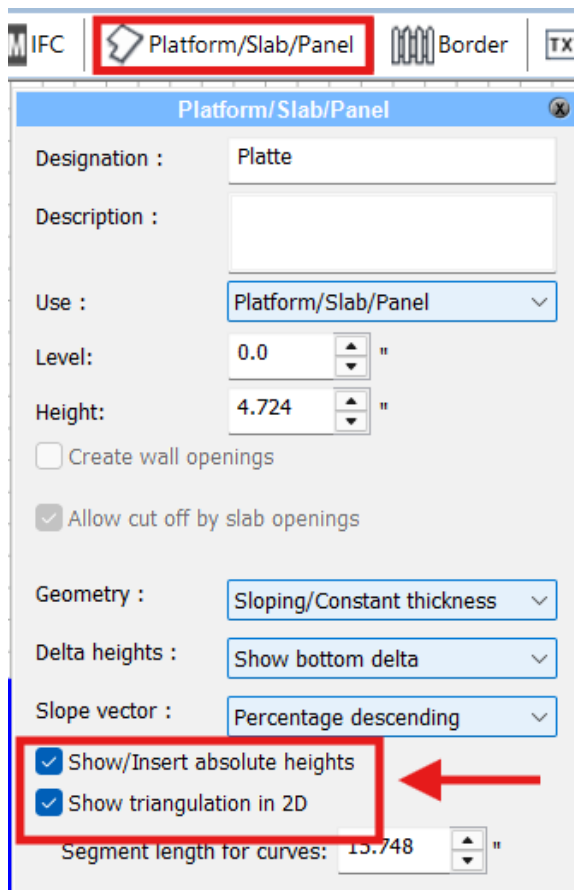

### Slab

A simple slab drawn as a polygon with the bottom edge = level and the height (30cm)

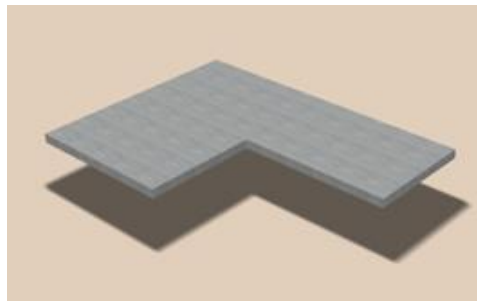
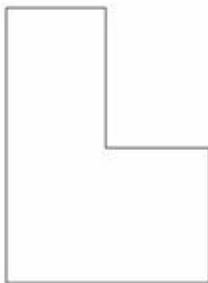

### Intersected slabs

Two slabs (intersected), in this case drawn with different levels.

The first panel drawn (L-shaped) cuts out the overlapping area from the second.

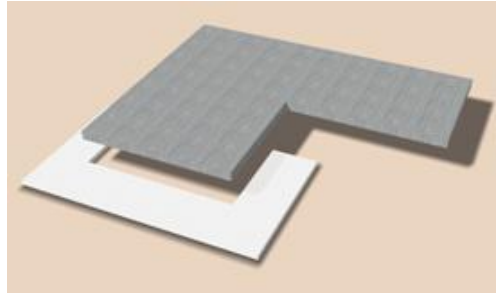
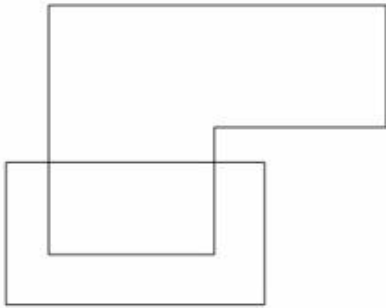

### Panel with cut-outs

A panel (cut) with two cut-outs. The level of the cut-outs has no influence on the result; the projection of the cut-outs is always cut out of the panel. Cut-outs can also protrude beyond the edge of the panel, as shown in the illustration. Recesses and panels must be on the same floor, the layer is not important.

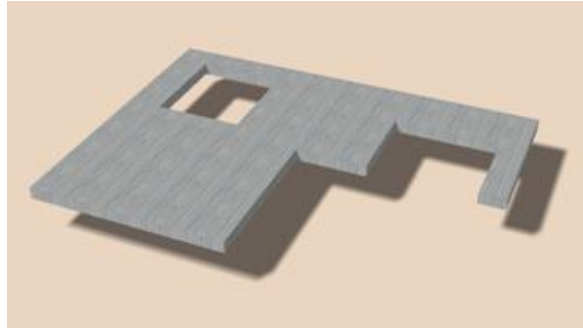
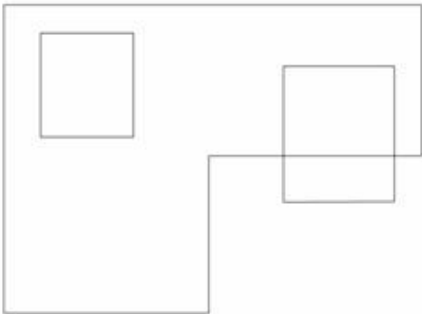

### Material area on walls

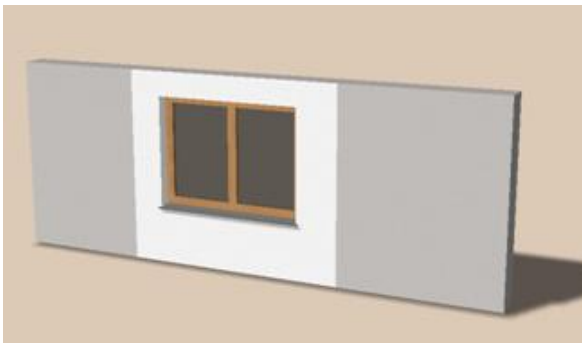

A material area has been drawn on the wall segment in a construction level of the wall. Openings are automatically omitted. Panels or recesses have no influence on material areas.

Material areas can only be changed in height, but not in level. The bottom edge is always on the wall surface (or room surface)

### Material area in rooms

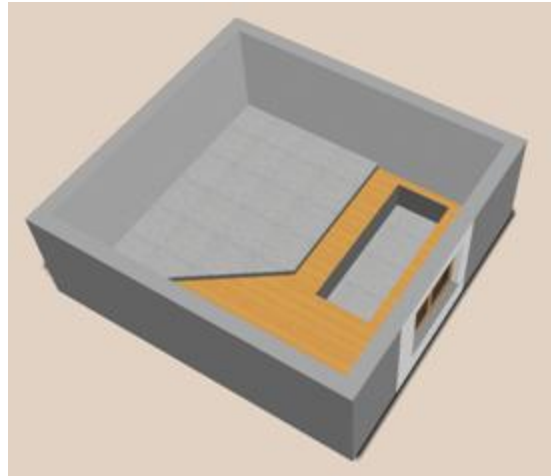
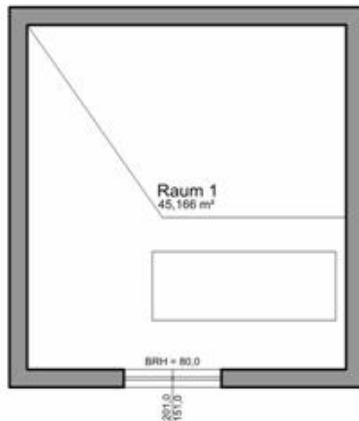

In construction mode, a material area is drawn in the room surface. The height can be entered as positive (as a platform) or negative (as a pit) as shown.

### Height and level

The height of the slab is defined in this dialog. The level is defined as the distance to the floor of the storey.

### With automatic miter

This function is only important for material areas on wall segments. If a height is entered for the material area and this is taken to the side boundary the material area is mitred for correct 3D representation.

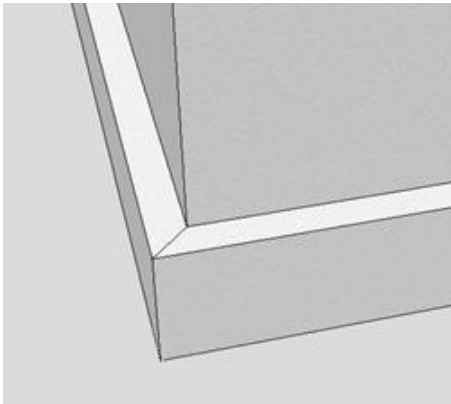

### Intersect with ceiling holes

With this option, slabs are intersected with the ceiling holes of the storey below.

### With border

This option is used to create border objects (described below) during input. This can lead to performance losses with more complex objects.

#### 12.8.2.3 Surface

Set the material for the top, bottom and side surfaces of the panel. Further information can be found on [the surface](#) <sup>[145]</sup> in the [General properties dialogs](#) <sup>[134]</sup> chapter.

12.8.2.4 Border

3D objects can be lined up along the side edges of a panel. In the **border object** properties dialog, first activate the **Show border object** option and select the desired object from the selection list.

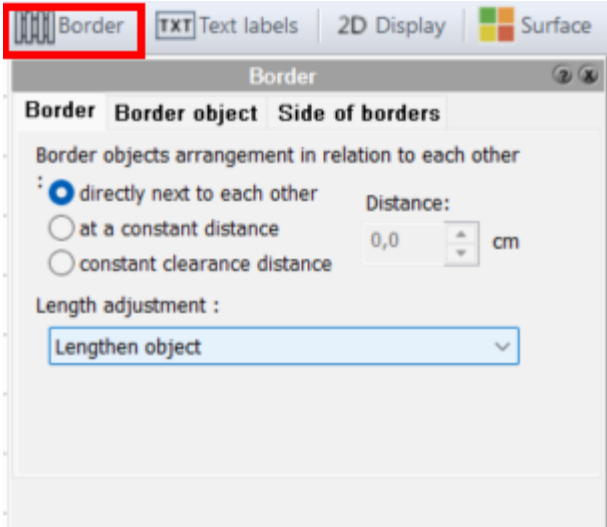

If no borders have yet been used in this project, only the **Load object** entry is available in the selection list. This allows you to select a 3D object from the object library.

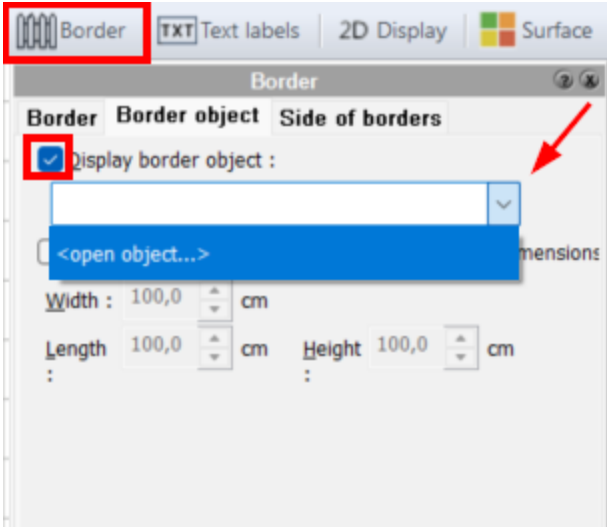

The 3D object explorer opens:

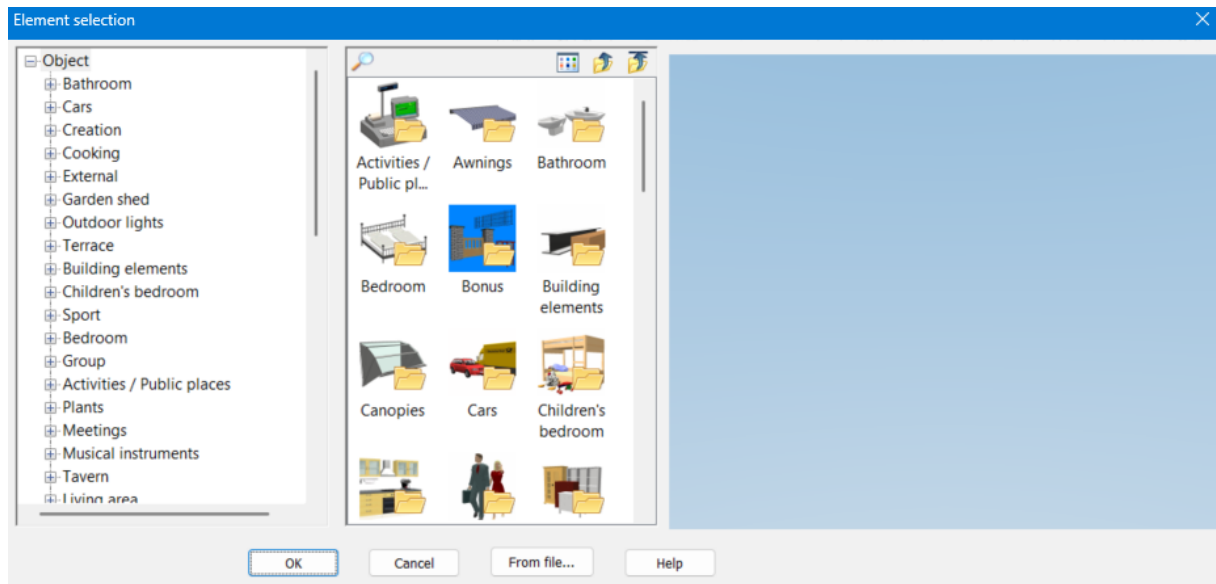

If a 3D object is selected, the dimensions of the object are displayed in the *Width*, *Length* and *Height* fields. Optionally, these values can also be changed.

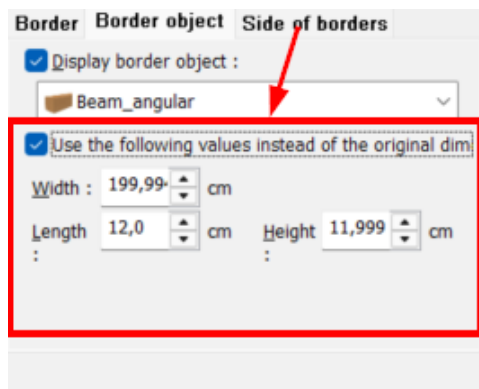

In the **Border** properties dialog, you can specify whether the objects along the side edges

- directly next to each other (without spacing)
  - with constant spacing (distance from axis to axis)
  - with constant clearance (distance between the objects)
- are placed. The spacing for the 2nd and 3rd option is set in the input field.

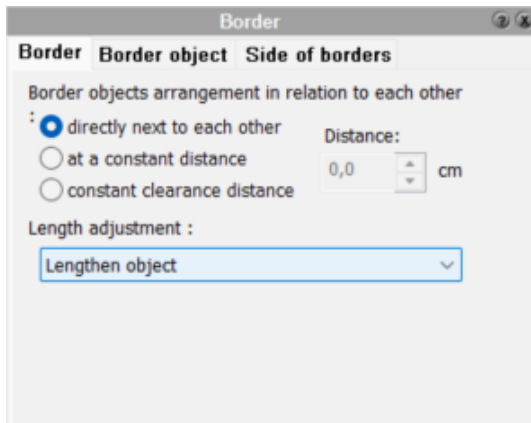

### Extend objects

The objects are automatically placed along the side edges. The object is inserted as often as the object width and the selected optional distance between the objects allow. However, for all side lengths not equal to a multiple of the object width plus spacing, a residual piece is created.

In the **Extend** objects selection list, you can set how this remaining piece is divided:

- **Extend** objects - The object width is enlarged so that no remnant remains.
- Leave space **at the beginning** - The remnant is left free at the beginning of the page.
- Leave space **at the end** - The remnant is left free at the end of the page.
- Leave space **at the beginning and at the end** - Half of the remaining piece is left free at the beginning and half at the end of the page.
- **Extend the space between the objects** - The distance between the objects is increased so that there is no leftover space.

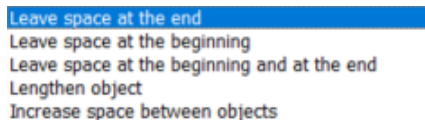

### Border pages

In this dialog, select which side of the panel is to be equipped with border objects.



#### 12.8.2.5 Layer/Floor, Size/Position, Contour/Fill/Hatching

Further information on the [layer/floor](#)<sup>[143]</sup>, [size/position](#)<sup>[143]</sup>, [contour](#)<sup>[138]</sup>, [fill](#)<sup>[140]</sup> and [hatching](#)<sup>[141]</sup>, [surface](#)<sup>[145]</sup>, [masses](#), [PosNr](#)<sup>[263]</sup>, and properties can be found in the chapter [General properties](#)

[dialogs](#) 

### 12.8.2.6 Edit points

The functions in the Contour tools area can be used to insert additional points or delete points in a tile that has already been drawn.

You can move points by moving the mouse pointer over the corner point of the unselected tile and dragging the point to the new position while holding down the left mouse button. Note that the corner point is highlighted in red at the start of the move. This activates snap mode and the point can be placed precisely.

Note: In the **general input options**, the option **also move unselected elements with the mouse** must be activated.

### 12.8.3 Edit

The menu item **EditSlab** in the drop-down menu can be used to subsequently change drawn slabs.

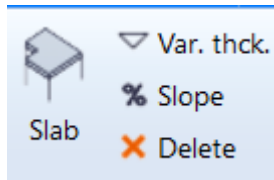

The following options are available:

Var. thickness: Add height point  
 Gradient: Add gradient  
 Delete: Remove elevation point/slope/slope

## 12.9 Windows/Doors/Wall Recesses/Roof Windows

Windows, doors and wall openings are summarized in one chapter in this manual, as the components are very similar in many areas. The common term for all three component types is **wall opening**. The system provides a two-stage processing concept for wall openings.

### Stage 1

This is editing in the properties dialogs. Parameters such as width, height, parapet height, material, etc. are set here.

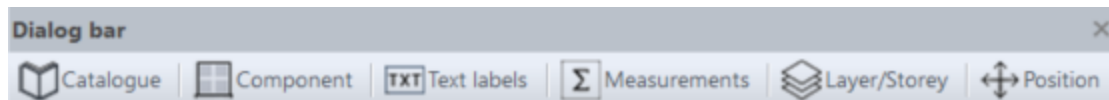

### Level 2

**Advanced editing** is carried out using a separate editor, in which the geometry of the wall opening is defined in addition to the parameters of the properties dialogs, i.e. whether a window sash is rectangular, triangular or round, for example.

### 12.9.1 Overview of wall openings

#### **Windows/roof windows**

A window/rooflight consists of the window frame, the window sash and the window glass/panel.

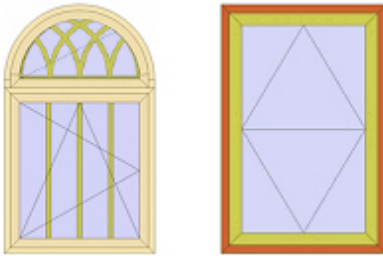

### Doors

Doors consist of a door frame and door leaf.



### Recesses

Except for the opening in the wall, recesses do not create any elements.

All three types of opening can be freely combined with each other. A window can be drawn with a recess (radiator recess) as a single element.



## 12.9.2 Place

The various options for placing windows/doors/recesses are listed in the selection bar.

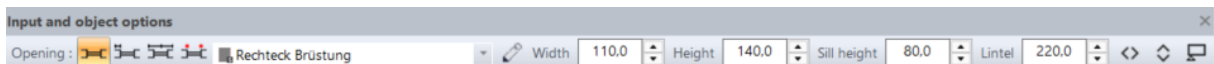
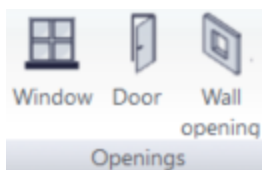

### Draw window/door/wall opening

Required input: 2 points

First the position, then the inside of the window



Possible input options: Side - left, center or right. Can also be changed with the **W** key

- **Window/door/wall opening at a distance**

Required input: 2 points and, if necessary, the distance

The reference point is entered first, then the direction and the inside of the window with a point. If the *Inquire* option is active, a dialog for entering the distance appears.



Possible input options:

Side - left, center or right. Can also be changed with the **W** button

Distance - the distance from the reference point

Query - the distance is queried before setting down

- **Window/door/wall opening centered**

Required input: 3 points

First enter two points between which the window is to be placed. The window is displayed according to the division ratio. Now select where the inside should be.



Possible input options:

Side - left, center or right. Can also be changed with the **W** button

Division ratio - 50% means centered

- **Window/door/wall opening left, right**

Required input: 4 clicks/ 2 points

The first click determines the wall element (position), the second click (1st point) determines the start of the

window, the third click (2nd point) determines the end of the window (thickness is thus defined)

and the 4th click determines the direction of opening



Possible input options:

Determine left/right stop with an additional input step

### 12.9.3 Position

Move the component depending on the wall corners (left/right, front/rear):

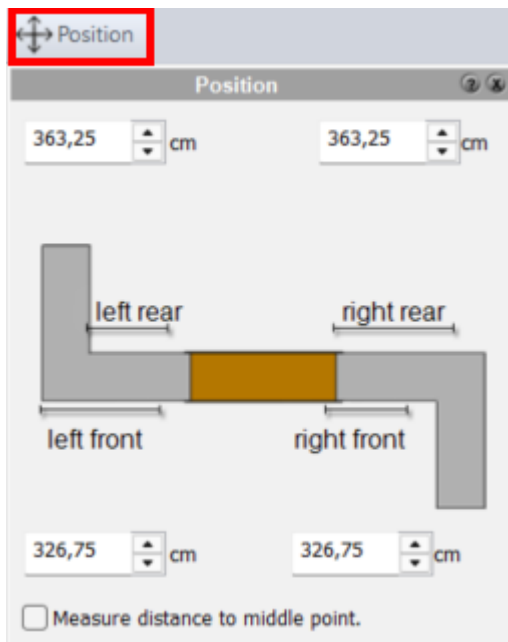

## 12.9.4 The overview bar



The dimensions, the mounting direction and the current component template are displayed in the overview bar.

Options:

**Swap left and right for the component (e.g. to set a door stop from right to left):**



**Swap front and back for the component (e.g. to allow a door to open to the other side of the wall):**



**Also take parapet height from catalog:**



## 12.9.5 Property dialogs



### 12.9.5.1 Catalogue

Windows that are used frequently are stored in the catalog. Further information on [catalogs](#)<sup>[150]</sup> can be found in the [General properties dialogs](#)<sup>[134]</sup> chapter.

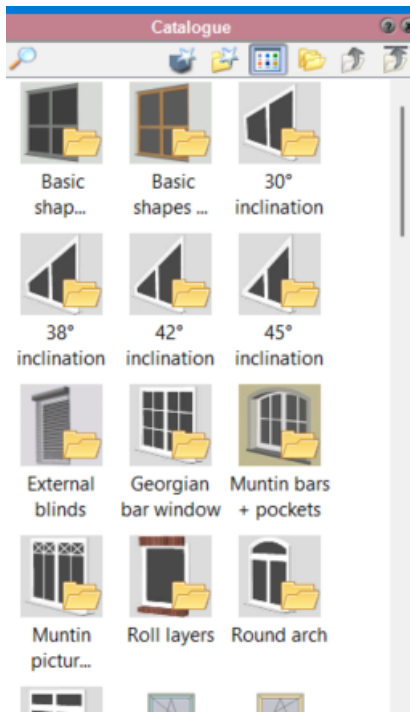

### 12.9.5.2 Component

[Catalogue](#) 

## 12.9.5.2.1 General settings

The screenshot shows the 'Component' dialog box with the following settings:

- Component** (selected tab)
- Window sills**, **Roller shutters box**, **Shutters**
- Corner/Smoothing Dimensions**, **2D display**
- General settings** (selected sub-tab), **Selection**, **Material**, **Frames**
- All Measurements:**
  - Height: 151,0 cm
  - Width: 101,0 cm
  - Sill Level from Finished Floor Level: 75,0 cm
- Switch left to right
- Switch front and back
- Visible in other storeys
- Open:** 0,0 (with a slider bar)
- Window framework:**
  - Width: 6,0 cm
  - Depth: 6,0 cm
- Door casing:**
  - Width: 12,0 cm
  - Depth: 1,0 cm
- Position of window framing / Blocking in wall:**
  - Center
  - Distance to the Interior (Distance: 0,0 cm)
  - Distance to the Exterior
- Wall recess:**  none,  inside,  outside
- Wall recess width:**
  - left: 6,25 cm
  - right: 6,25 cm
  - above: 6,25 cm
  - below: 0,0 cm
- Advanced editing...**
  - Frame side: Left
  - Widening: None
  - Increase: 5,0 cm
  - Allowance for: 3,0 cm

These settings apply to the entire wall opening.

Height, width and height above floor are the standard dimensions of the opening regardless of additional dimensions in **advanced editing**.

With **Open**, a percentage value can be set by which all openable sashes of the element are opened in 3D mode.

The dimensions of window frames and door frames apply to all sashes drawn in the component.

The position - in relation to the wall - can be defined for windows and doors with block frames.

Window stops can be set for inside or outside. Wall layers are optionally routed across corners (settings for this in the wall).

**Advanced editing** is described below.

The image shows a software dialog box with the following controls:

- Frame side:** A dropdown menu set to "Left".
- Widening:** A dropdown menu set to "None".
- Transfer to all side!** A button.
- Increase:** A dropdown menu set to "Increase".
- 5,0 cm:** A numeric input field with a spinner, showing the value 5,0 and the unit cm.
- Allowance for:** A checkbox that is currently unchecked.
- 3,0 cm:** A numeric input field with a spinner, showing the value 3,0 and the unit cm.

In this dialog, it is possible to set frame doublings or work with installation air.

## 12.9.5.2.2 Selection

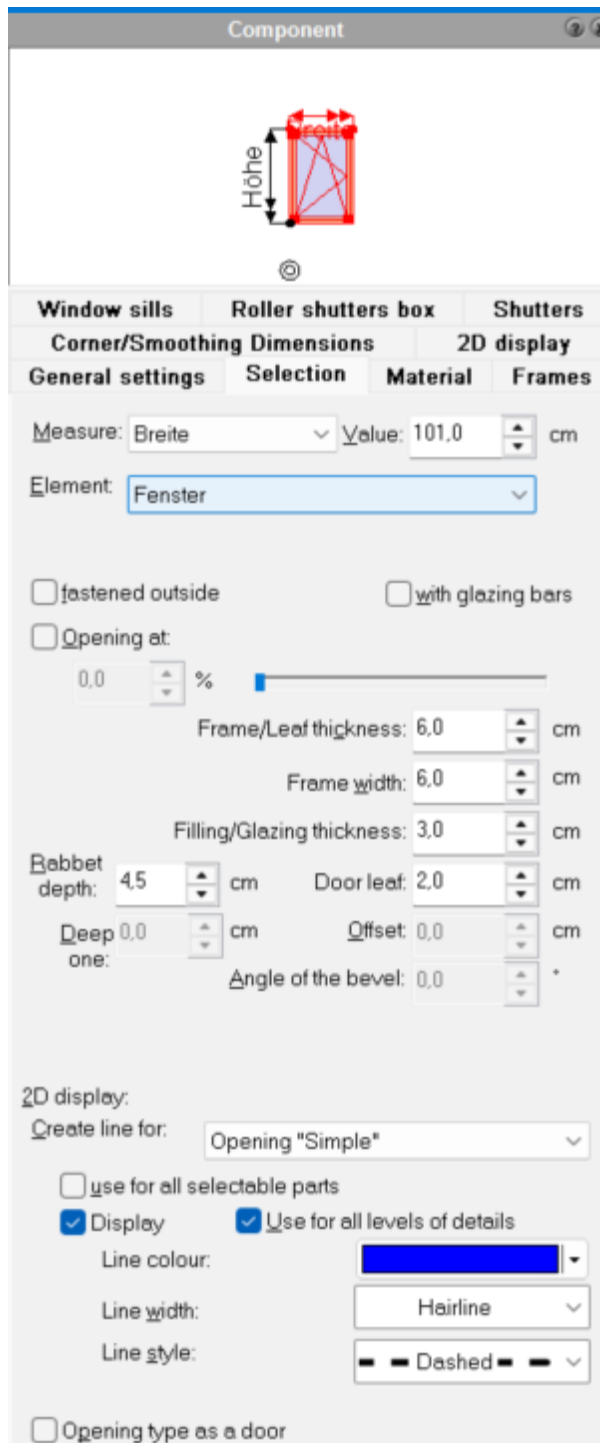

Settings for a sash of the wall opening are made in this tab. Select the sash in the upper preview with the mouse; it is shown selected in red. If there is only one sash, it is automatically selected.

In the **extended editing**, dimensions can be placed, these dimensions can also be selected and the associated value can be changed.

The selected dimension and the selected sash are displayed in the selection lists.

**Hinged on the outside** causes the selected sash to be hinged on the outside.

If the option **Muntins** is active, window muntins are displayed. Further settings for glazing bars can be found in **advanced editing**.

The parameters for **frame/leaf thickness, frame width, infill/glass thickness** etc. only apply to the selected sash.

The 2D replacement representation is the setting for this sash regarding **frame/frame, aisle type** and **infill/glass**. Settings for the entire wall opening can be found in the **2D representation** tab. For the areas, select the representation of the lines in the selection lists.

**Use for all selectable parts** transfers the settings to all sashes of the openings.

**Display** is deactivated to not display the selected detail of the sash. The display can be selected in the selection list depending on the level of detail. If all levels of detail are to be displayed in the same way, activate the corresponding option. The level of detail for the project is selected in the **View/level of detail** menu.

If you activate the option **"Same as door"**, the direction in which the window sashes open is displayed as a quarter circle - as with doors.

#### 12.9.5.2.3 Shading elements on the window

Shading elements can be attached directly to the window by marking the window in the design and

clicking on the container  and then on **Roller shutter box**:

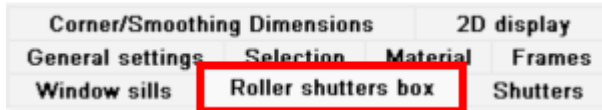

The type of shutter box can be selected from a catalog:

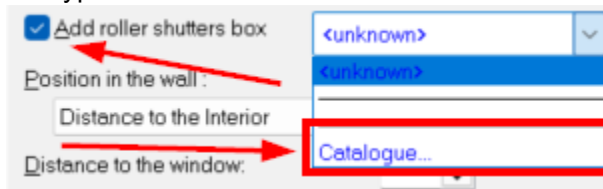

The position of the shutter box can be defined

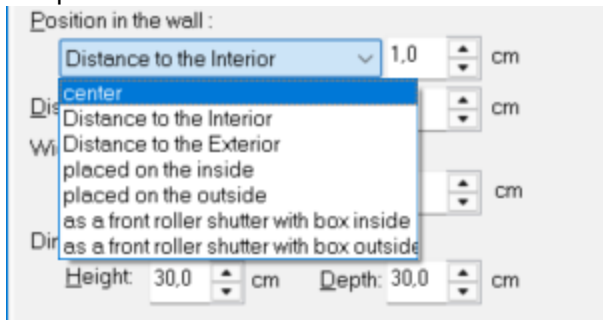

The cross-section can also be selected

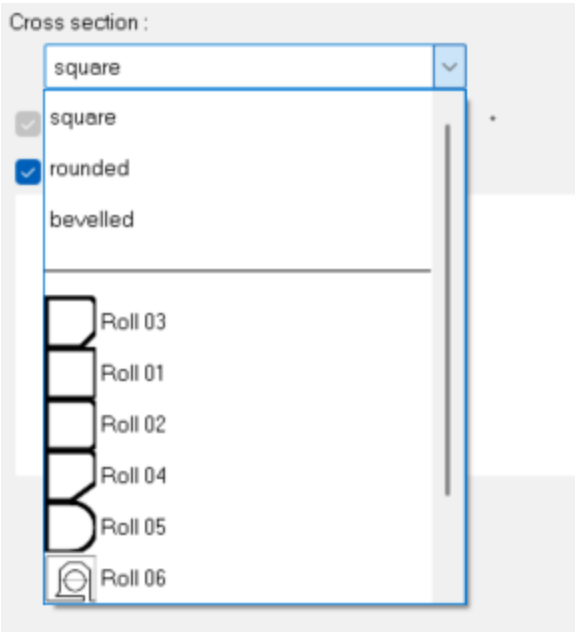

The shutter is displayed correctly in the sectional view.

**Shutters:**

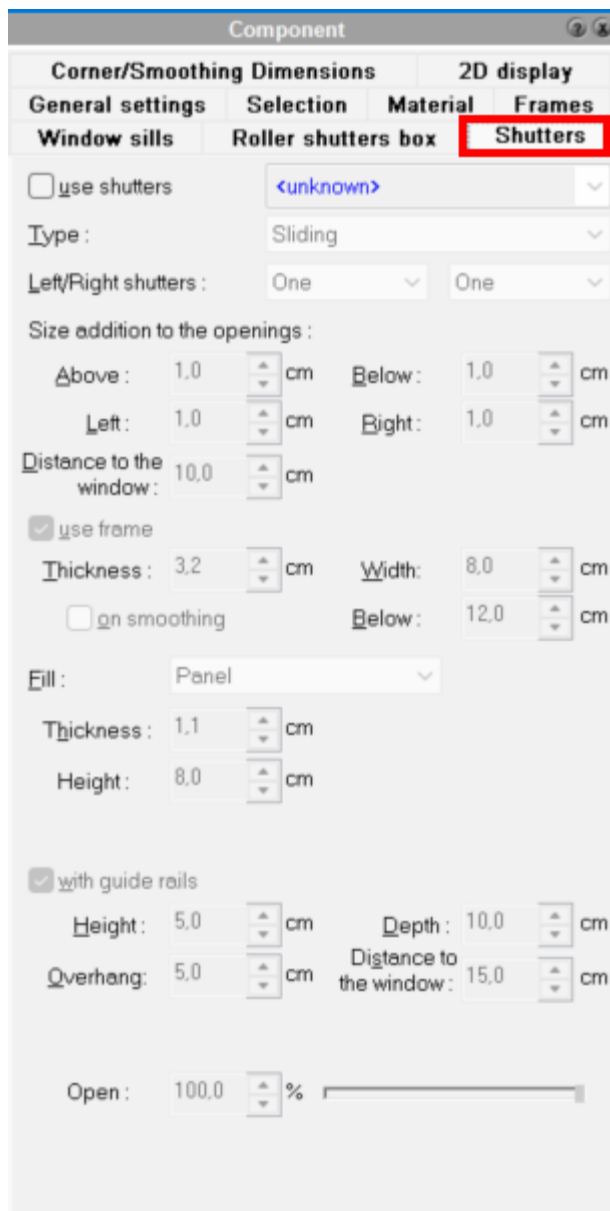

These can again be selected from a catalog, the type can be selected:



and various other parameters can be set. The object is directly linked to the window and reacts to changes in size and position

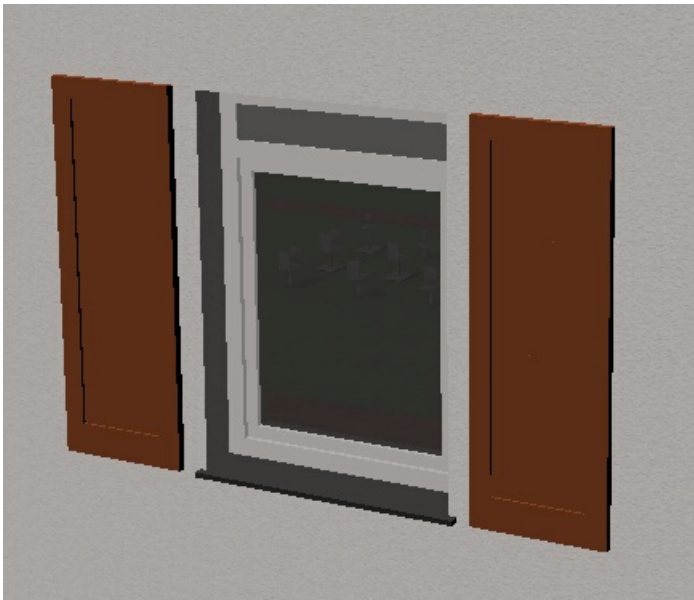

## 12.9.5.2.4 2D replacement display

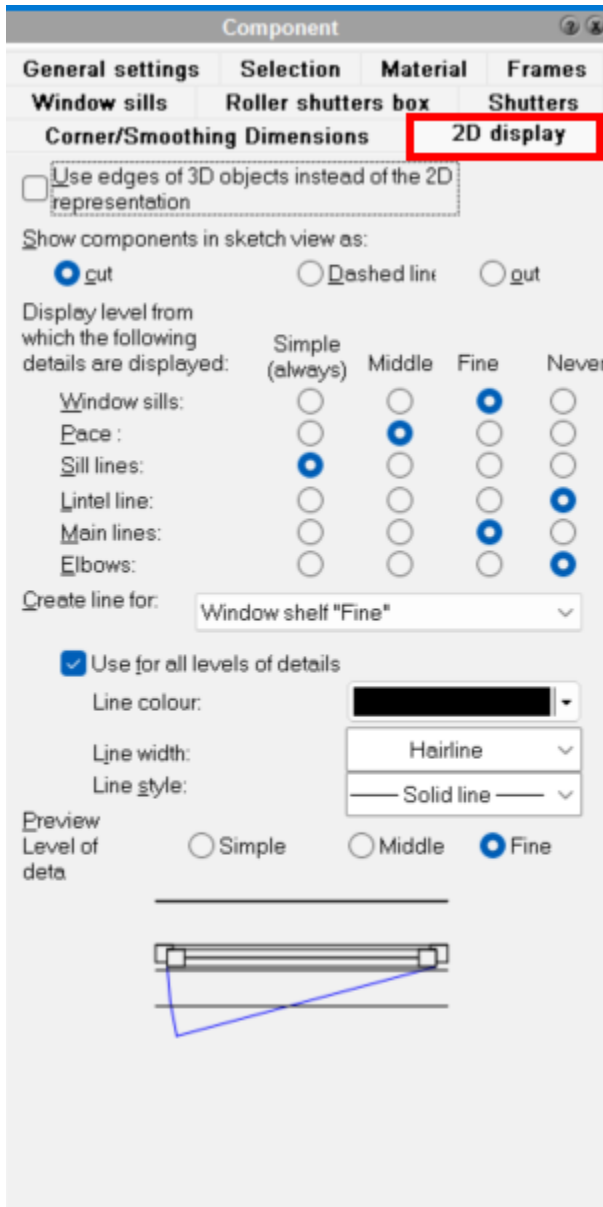

The 2D representation of the entire wall opening is recorded in this dialog.

The **sectioned** view is standard; dashed is required to correctly display elements outside the section height (such as fanlight windows). The display can also be switched off completely in order to construct the 2D display with 2D elements.

The matrix is used to set which detail of the 2D representation is shown from which level of detail. You can now select the detail for which [line properties](#)<sup>138</sup> are defined in the selection list.

## 12.9.5.2.5 Corner/Miter design

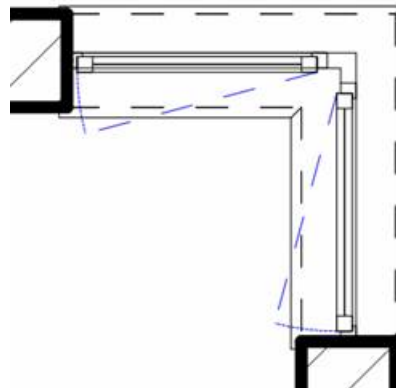
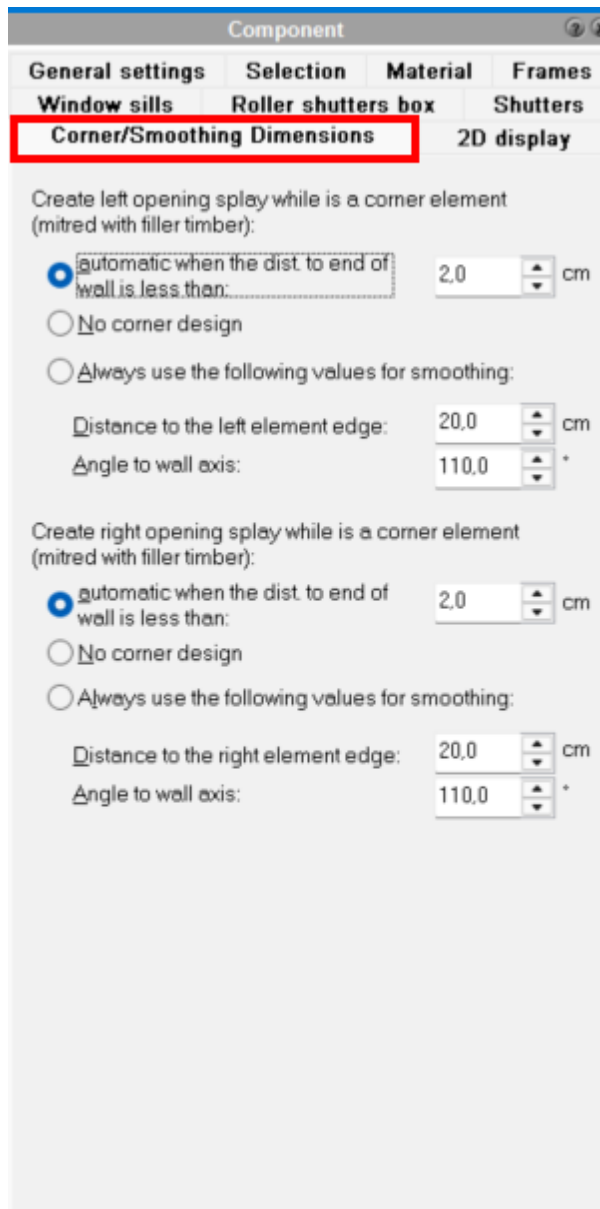

The corner design can be activated for windows, doors and recesses. For the corner design, frames and window sills are cleanly cut in the floor plan and in the 3D model. The position of the openings is determined by the dimensions of the additionally displayed corner profiles. The corner design can be set separately for the left and right side.

This option is normally activated **automatically**. Corner formations are then generated as soon as the opening is closer than the distance value entered next to the option.

**No corner** formation is activated if window openings are placed directly at the wall node/corner, but no corner formation is constructed (see illustration below).

The **always** option should only be activated for special cases. The distance and angle of the opening must be adapted to the position and orientation of the walls.

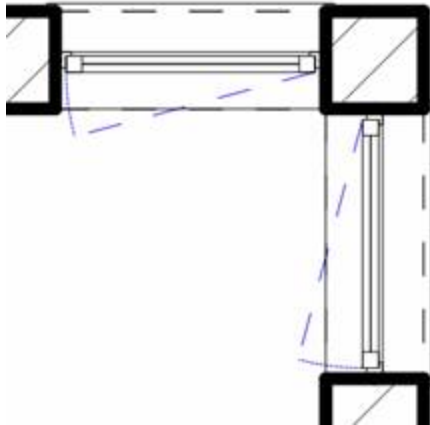

## 12.9.5.2.6 Window sills

Component			
General settings	Selection	Material	Frames
Corner/Smoothing Dimensions		2D display	
<b>Window sills</b>	Roller shutters box	Shutters	
<input checked="" type="checkbox"/> Add interior windowsill			
Project sill down:		2,0	cm
Project sill inward:		0,0	cm
Left/Right Projection:	0,0	cm	0,0
<input checked="" type="checkbox"/> Sill Level at Finished Floor Level below			
<input checked="" type="checkbox"/> Add exterior windowsill			
Project sill down:		2,0	cm
Project sill outward:		0,0	cm
Left/Right Projection:	0,0	cm	0,0
Slope of exterior window sill:		0,0	°
<input checked="" type="checkbox"/> Sill Level at Finished Floor Level below			
<input type="checkbox"/> The lower edge of the window sills is flush with the frame			

Window sills are displayed in the floor plan and in the 3D model. The display in the floor plan depends on the level of detail and the parameters in the **2D display** tab.

If the option is **also** deactivated **for sills at floor level**, the window sill is hidden for floor-to-ceiling windows and especially doors; if this option is activated, the window sill is always shown.

The roller shutter box is displayed in the 3D model and therefore in sections. Select how the roller shutter box is positioned in relation to the wall. The distance is added to the reference axis. The width allowance allows the roller shutter to protrude to the side.

The external window sills can also be selected to be flush with the frame.

## 12.9.5.2.7 Window pockets

Component

Corner/Smoothing Dimensions 2D display

Window sills Roller shutters box Shutters

General settings Selection Material **Frames**

Frame outside:

with exterior frame

Width of frame (0 for no trim):

Left: 10,0 cm Right: 10,0 cm

Above: 10,0 cm Below: 10,0 cm

Shifting of the rear frame surfaces relative to the wall surface: 1,0 cm

Frame inside:

with interior frame

Width of frame (0 for no trim):

Left: 10,0 cm Right: 10,0 cm

Above: 10,0 cm Below: 10,0 cm

Shifting of the rear frame surfaces relative to the wall surface: 1,0 cm

Window frames can be set separately for **outside** and **inside**. The width of the frames can be recorded separately for **left**, **right**, **top** and **bottom**. To show no chamfer **at the bottom**, set the corresponding value to **0**.

Shifting to the wall surface allows you to create flaps that are not flush with the wall surface. Negative values create flaps that lie behind the wall surface. The material is defined in the **Material** tab.

## 12.9.5.2.8 Material

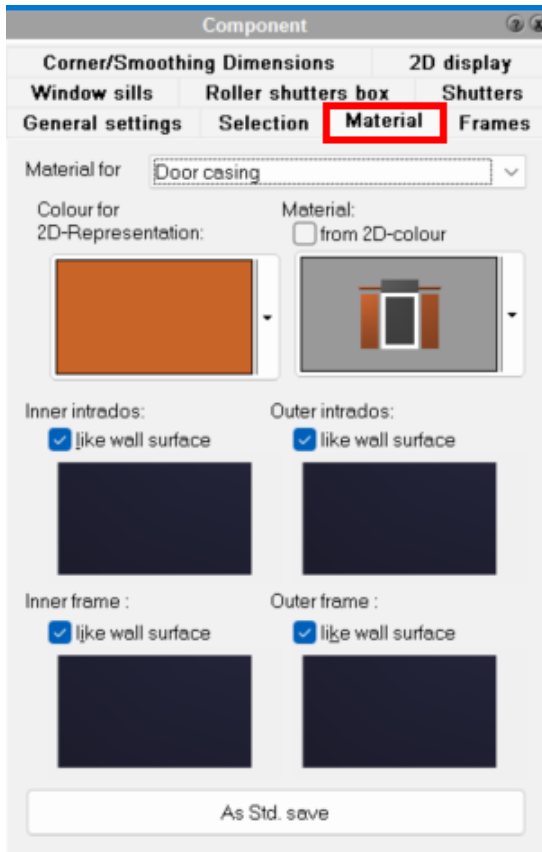

In the selection list, choose which element of the wall opening is to be textured. You will see a preview of the **color for the 2D display** (for display in the catalog) and the actual material for the 3D display to the right of it. Window reveals and reveals can automatically receive the material that is assigned to the wall segment of the opening. Different material can be entered if you deactivate the option **such as wall surface**. In this dialog, you can define the [Material property](#)<sup>[436]</sup> of the elements in 3D mode.

### 12.9.5.3 Labeling

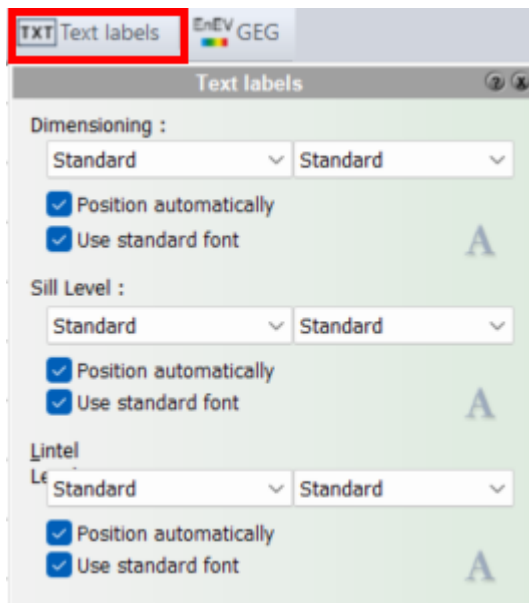

Wall openings can be automatically displayed with the axis dimension, the parapet height and the lintel height. The text properties are set in this properties dialog.

The following applies to all three texts:

The left selection controls the visibility. **Standard** corresponds to the settings in the standards **Project Labeling - Window tab and Doors**.

**Do not show** or **Show** are then set exclusively for this window.

The selection list on the right determines the position of the dimension text on the **inside** or **outside**. The same applies to **Standard** as described above. All texts can be moved with the mouse. The **Position automatically** option is then deactivated. If you activate the option, the text is displayed in the standard position again.

The default font corresponds to the settings from the **Project Labeling menu - Windows and doors** tab. If you deactivate the option, an independent font setting can be made for this text.

### 12.9.5.4 Properties

Further information on the [properties](#)<sup>[145]</sup> can be found in the [General properties dialogs](#)<sup>[134]</sup> chapter.

### 12.9.5.5 Layer/Floor

You can find further information on [layers/floor](#)<sup>[143]</sup> in the [General properties dialogs](#)<sup>[134]</sup> chapter.

### 12.9.5.6 Position

Move the component depending on the wall corners (left/right, front/rear):

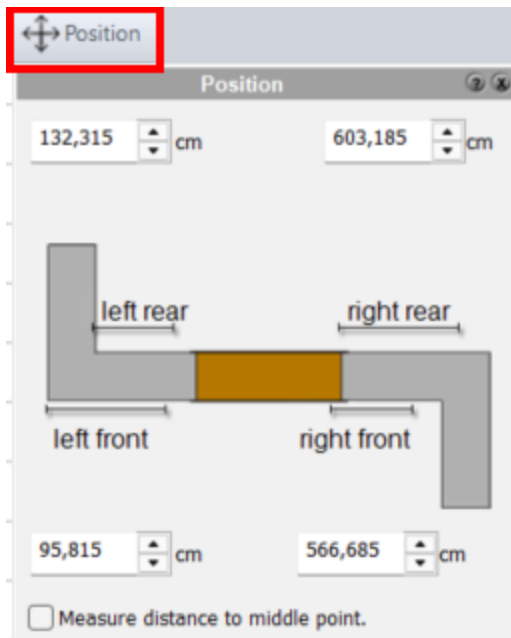

## 12.9.6 Advanced editing/window designer

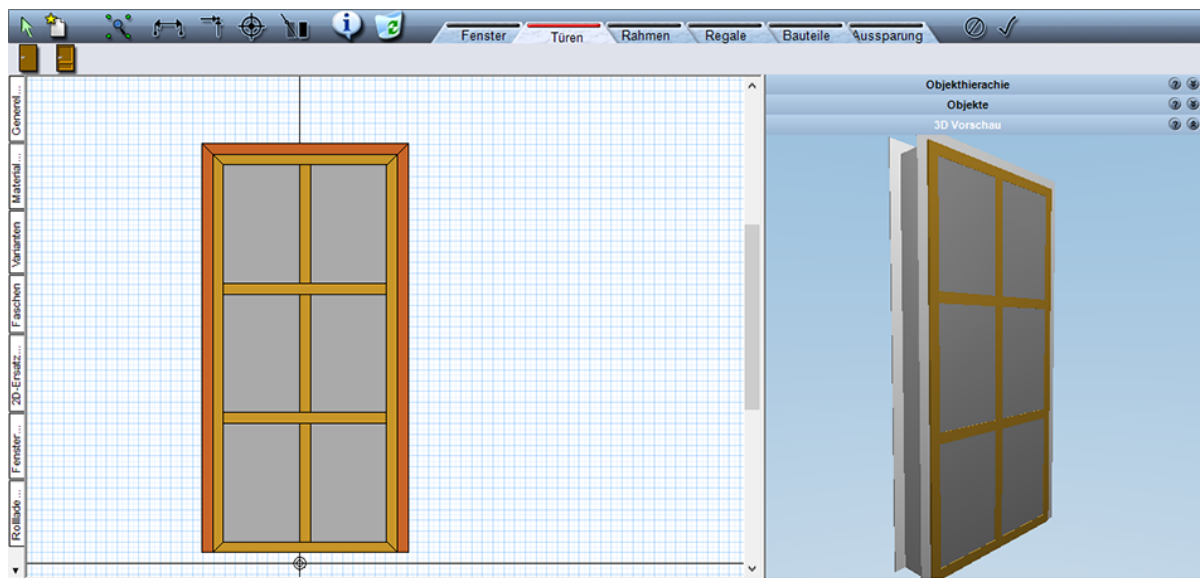

### 12.9.6.1 General settings

In **advanced editing**, windows, doors, frames, components, shelves and recesses can be edited or newly created.

Activate window/door/wall recess in the planning:

Click on the **Component** button in the properties dialog and then in the **general settings**:

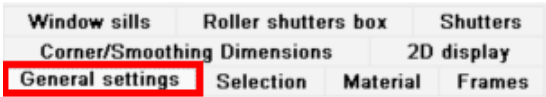

under the input values, click on the button: Activate **advanced editing**:

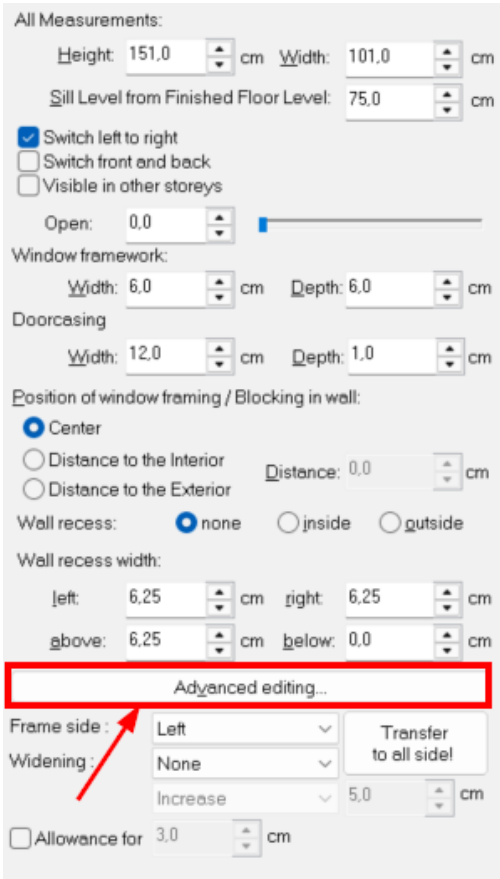

, then the following input mask appears (detailed editing of elements):

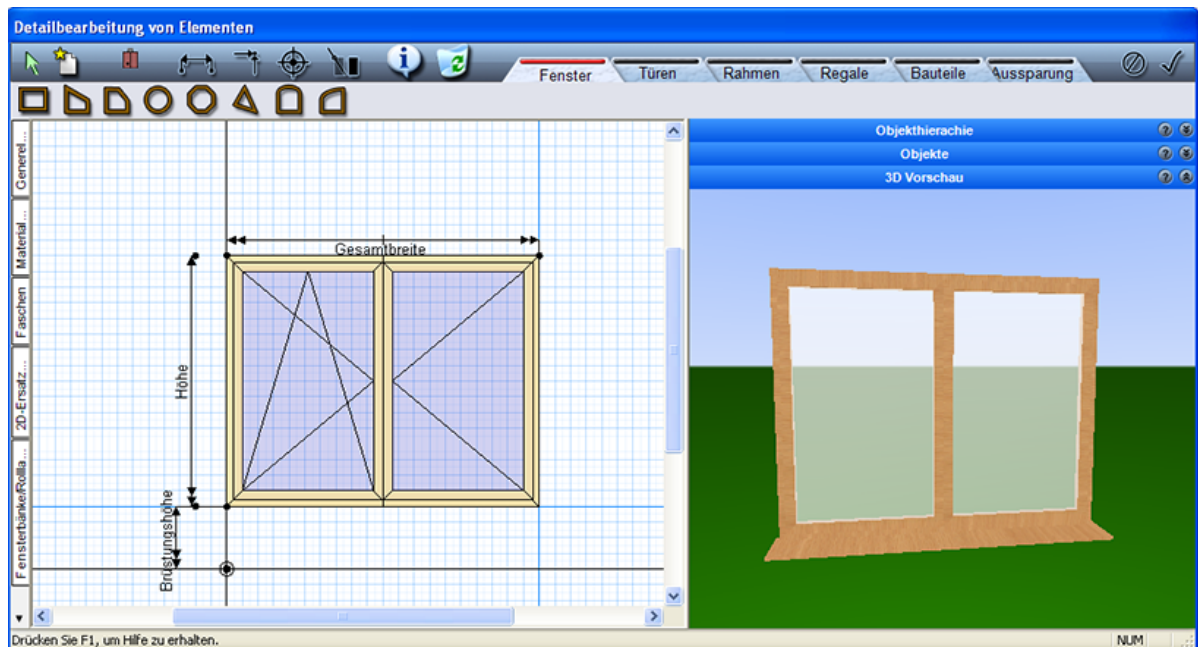

In **advanced editing**, windows, doors, frames, components, shelves and recesses can be edited or newly created.

#### Example windows:

In the editing program, windows can be

can **be changed**, e. g .

\* aisle types, \*settings of the frame and sash components, \*settings of the inclination angle for slanted windows...

**can be extended:**

\*frame components, \*muntins, \*objects...

And **new ones** can be created!

On the left is the 2D preview, on the right the 3D preview. Next to the 2D preview there are tabs which correspond as far as possible to the setting options under the main container 'Component'! Under ' **General** ', the setting of the grid is an important point for creating new windows; the grid is the basis for assembled, parameterizable components!

The object structures can be activated above the 3D preview (more on this later when inserting objects)

If the upper mode 'Window' is active (happens automatically when you start editing via the component window), then all possible window components are also displayed



These components can be used to create new windows in various shapes. To create a new window, you should activate a similar window from the existing catalog and then modify it.

If a completely new window is to be created, an existing window is also inserted and activated. In

advanced editing, all existing component scan then be deleted via this button: .

And you get a new starting situation:

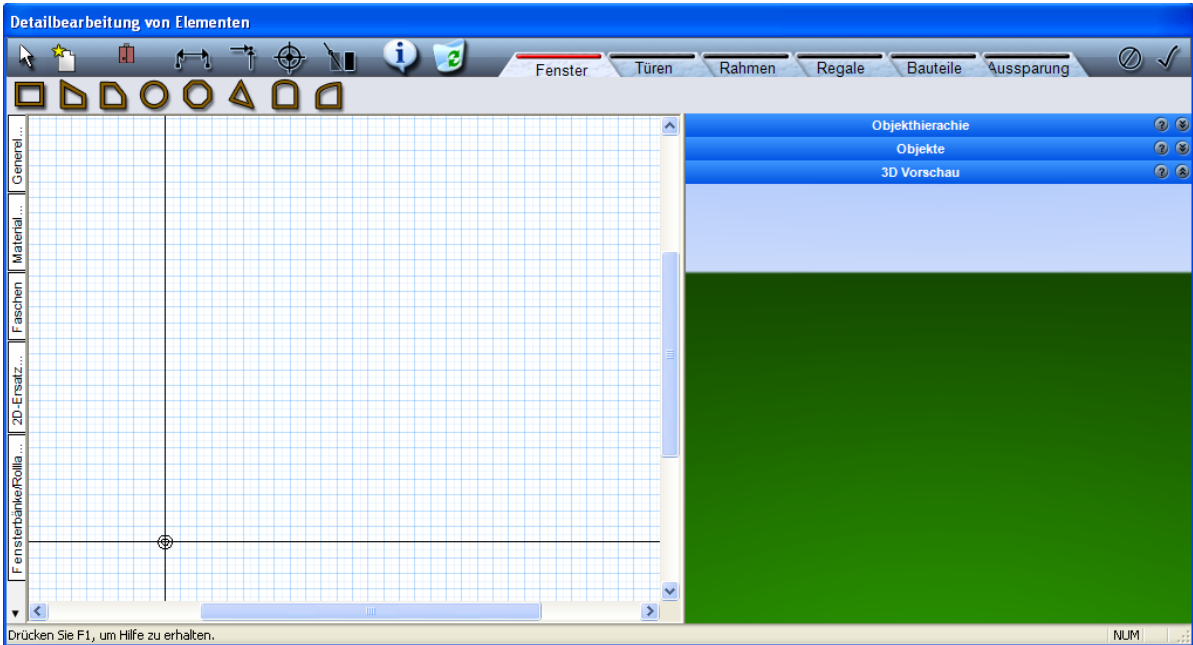

## 12.9.6.1.1 Wings

**WindowSheet**

**Object**

| General sash | Window framing | Balusters | 2D display |

Designation : Window

on/off       switched off

with framework      Frame width: 2.362 "      Frame thickness: 2.362 "

Opening at: 0.0 %

fastened outside       open first

Rebate depth: 1.772 "      Door leaf: 0.787 "

Fill type: Glazing      Fill thickness: 1.181 "

Sash type: Hinged and hopper      Slats height: 3.9 "       right resp. above

**Options:**

Designation  
 can be switched off/switched off  
 with frame  
 Frame width  
 Frame thickness

Lock opening on:  
 outside hinged/open first  
 Rebate depth/overlap  
 Type of infill/thickness of infill  
 Slat height  
 Sash type  
 right or top

**Door leaf**

**Object**

| Door leaf | Door casing |

Designation : Door

on/off  switched off

Door leaf thickness: 1.181 "

Opening type: Normal, fastened right

Opening at: 0.0 %

outside  open first

Rabbit depth: 0.591 " Door leaf: 0.394 "

Fill type: Normal door (without filling) Fill thickness: 1.2 "

Frame width (filled): 5.906 "

Correction dimensions for objects used as fillis:

Left: 0.8 " Right: 0.8 "

Top: 0.8 " Bottom: 0.0 "

Replace: 0.8 " Rotation: 90.0 Static

Object interchangeable

**2D display**

### Window sash options:



- 1 Retract rectangular sash
- 2 Retract trapezoidal sash
- 3 Retract general trapezoidal sash
- 4 Retract round sash
- 5 Insert general sash
- 6 Insert triangular window
- 7 Insert arched sash
- 8 Insert half arch sash

**Door leaf options:**

1 2



1 Insert simple door

2 Insert panel door

12.9.6.1.2 Frame

**Automatic frame**

Object
?
⌵

| General sash | Window framing | Balusters | 2D display |
?
⌵

Left:

Create      Keep free place

Full    Half    None       Full    Half

Right:

Create      Keep free place

Full    Half    None       Full    Half

Bottom:

Create      Keep free place

Full    Half    None       Full    Half

Top:

Create      Keep free place

Full    Half    None       Full    Half

**Options:**

left/right/bottom/top

create

full/half/without

Keep space free

full/half

**Free frames**

**Object**  
| 2D display |  
**Window framework elements**

Designation :

on/off       switched off

Place on grid at:

center       left       right

Cross section dimensions deviate from general settings

Width:  "      Thickness:  "

Depth offset of window framing:  "

along smoothing at the begi      Fulcrum:

Angle:       Stati  center  left  right

along smoothing at the end

Angle:       Stati  center  left  right

Wall opening enlargement

**Options:**

Designation:

Window element

can be switched off/disabled

Position of the frame element in relation to the grid points

center/left/right

Cross-section dimensions deviating from general settings

Width

Thickness

Depth offset in relation to the window frame:

with miter at the beginning

Angle

center/left/right

with miter at the end

Angle

center/left/right

enlarges the wall opening

**Frame options:**

1 2



1 Insert straight frame element

2 Insert contiguous frame elements

## 12.9.6.1.3 Rungs

**Rungs** tab:

**Object** [?] [x]

| General sash | Window framing | **Balusters** | 2D display [?] [x]

with glazing bars    Load...    Save...

Width: 1.181 "    Narrowing: 0.394 "

Thickness: 0.787 "

Glazing position: In the glazing inward and outward ▾

Horizontal glazing bars:

Use

Number/Distance:

Set the number to: 5

Dynamic, minimal offset: 11.811 "

Vertical glazing bars:

Use

Number/Distance:

Set the number to: 5

Dynamic, minimal offset: 11.811 "

Glazing bars configuration theme :

Use

▾ Move

Width: Scale ▾ 0.0 "

Height: Scale ▾ 0.0 "

**Options:**

Set the width, thickness and taper.

You can then choose whether you want a fixed number - centered horizontally and vertically, whether the muntins should be dynamic with a fixed minimum spacing (the number of muntins changes when the window component dimensions are changed), or whether you want to use a muntin image.

If you want to use a muntin bar pattern, this option must be clicked and the checkboxes for horizontal and vertical muntins removed.

After activating 'Use muntin bar image', you can select a suitable muntin bar image from the list below:

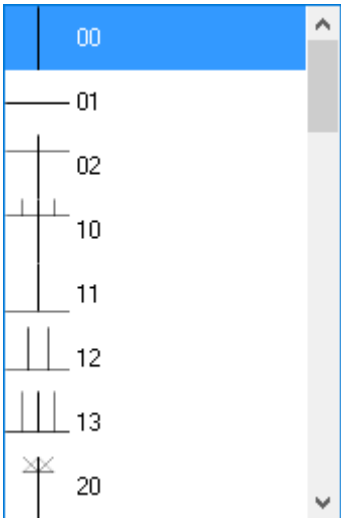

12.9.6.1.4 Shelves

**Object** [?] [v]  
| 2D display | [?] [v]  
| Shelf | Special shelf | Exteriors | [?] [v]

Designation : Rectangular shelf

on/off       switched off

Deep one: 15.748 [▲] [▼] "       for 1/2 Wall width

Wall width: 1.969 [▲] [▼] "

Rear offset: 0.0 [▲] [▼] "       for 1/2 Wall width

**Object** | 2D display | Shelf | Special shelf | **Exteriors**

Left:  Create  None  Keep free place  
 Right:  Create  None  Keep free place  
 Top:  Create  None  Keep free place  
 Bottom:  Create  None  Keep free place

with rear wall      Depth: 0.315 "

Rabbe depth: 0.197 "      Door leaf: 0.394 "

**Object** | 2D display | Shelf | **Special shelf** | Exteriors

Number of shelf columns: 3  
 Column number: 1 Help  
 merge with adjacent element

Tot. compartments in the column: 5      Set number for all columns!  
 Depth of Soil: 0.787 "      use for all floors!

Subject Number: 1 The column:  
 fused with underlayered material

Type of fill: Open panel

Set type for all spacings!      Set type for all shelf surfaces

**Shelving options:**

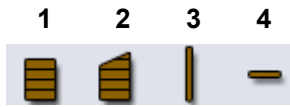

**1** Insert rectangular shelf

**2** Insert general shelf

**3** Insert shelf side

**4** Insert shelf

## 12.9.6.1.5 Objects

**3D-Object**

Designation : Garage door\_03 350\*350cm

on/off       switched off

interchangeable       front       rear

Reference point:

l.t.       c.t.       r.t.

l.c.       center       r.c.

l.b.       c.b.       r.b.

Position at this depth:

Object in back of behing lying cont. member

Maintain proportions (scale evenly)

Mirror

Size:      Rotation:      Move:

X: 137.796 "      0.0      Stat 0.0 "

Y: 2.362 "      0.0      Stat 0.0 "

Z: 137.794 "      180.0      Stat 0.0 "

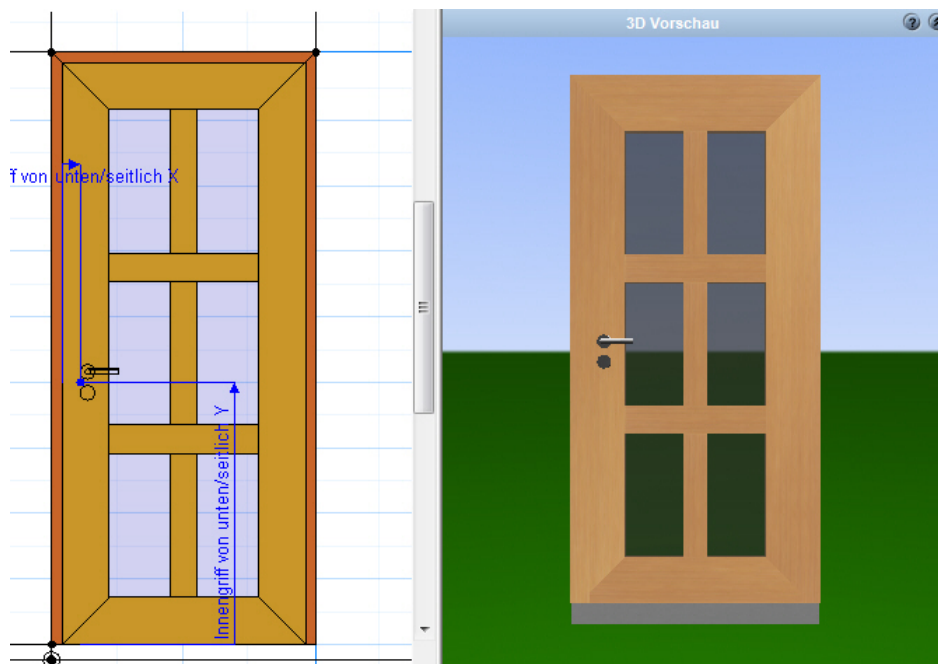

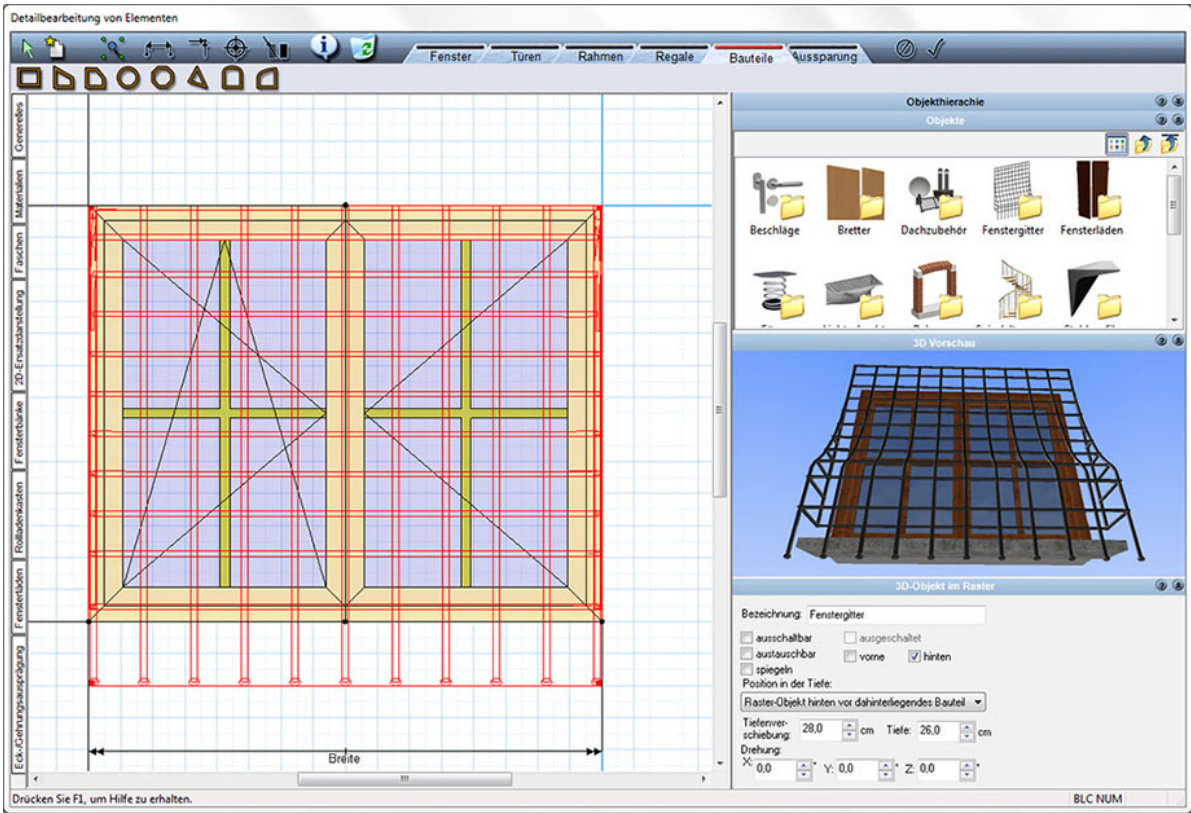
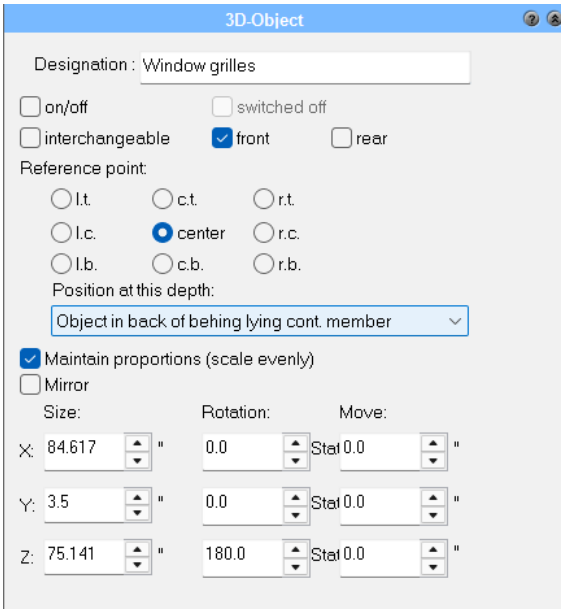

Objects/components Options:



1 Insert 3D object

## 2 Insert 3D object as parameter object

### 12.9.6.1.6 Recesses

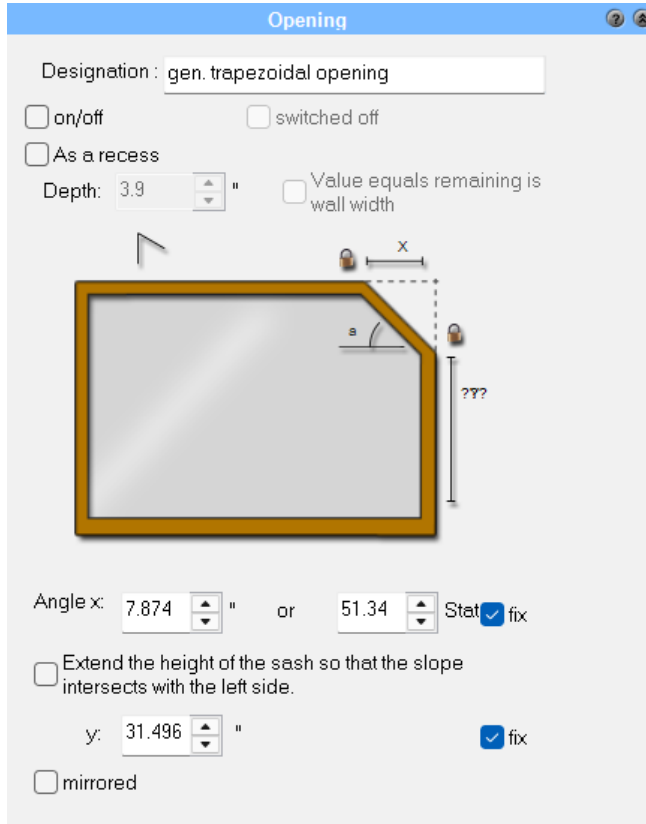

#### Options:

can be switched on/switched off  
 as niche  
 Depth cm  
 set value is remaining wall thickness  
 Top stitch cm  
 as basket arch  
 Bottom stitch cm  
 as basket arch

#### Recesses Options:



- 1 Draw in rectangular opening
- 2 Draw in trapezoidal opening
- 3 Insert general trapezoidal opening

4 Insert round opening

5 Draw in general opening

6 Draw in triangular opening

7 Draw in curved opening

8 Draw in semi-arched opening

### 12.9.6.2 Creation of a new window/window section

Open the form for advanced editing with the button in the **General settings** tab. Click on the **Advanced** editing button

#### Example: Double-sash window

In this example, the construction of a double-sash window is explained step by step.

- Click on the **Window** button
- Open the **Component** properties dialog
- Select the **General** tab and click on the **Advanced** editing button
- The Advanced **editing** dialog opens
- Click on the **Delete all elements button (empty planning)**
- In the **General** tab, set the grid spacing to 10 by 10 cm
- Select the **Window** mode and click on the **Draw rectangular sash** button
- Draw the first sash. Start as shown in the sketch.

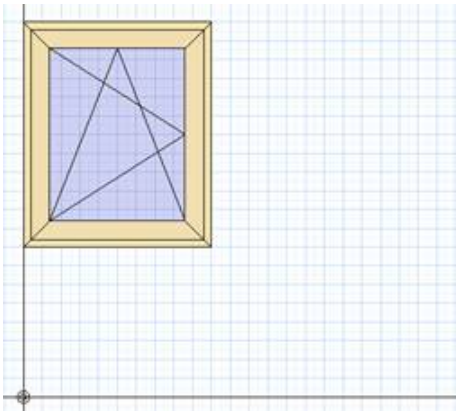

The grid spacing of 10 cm helps you to determine the size and sill height.

In this example, the window size is assumed to be 100 /120 cm and the sill height 80 cm.

However, these dimensions should only be regarded as guidelines, the exact dimensions will only be determined later.

- Draw the second sash in the same way as the first

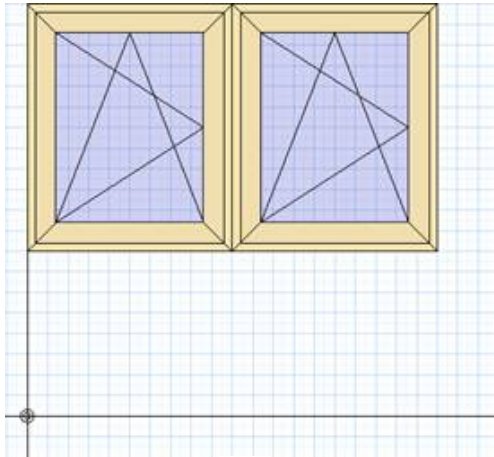

- End the input with ✓ at the top right.

### Example: additional frame part

As a rule, however, an existing window is taken as the basis and then a new frame + sash component is generated in addition:

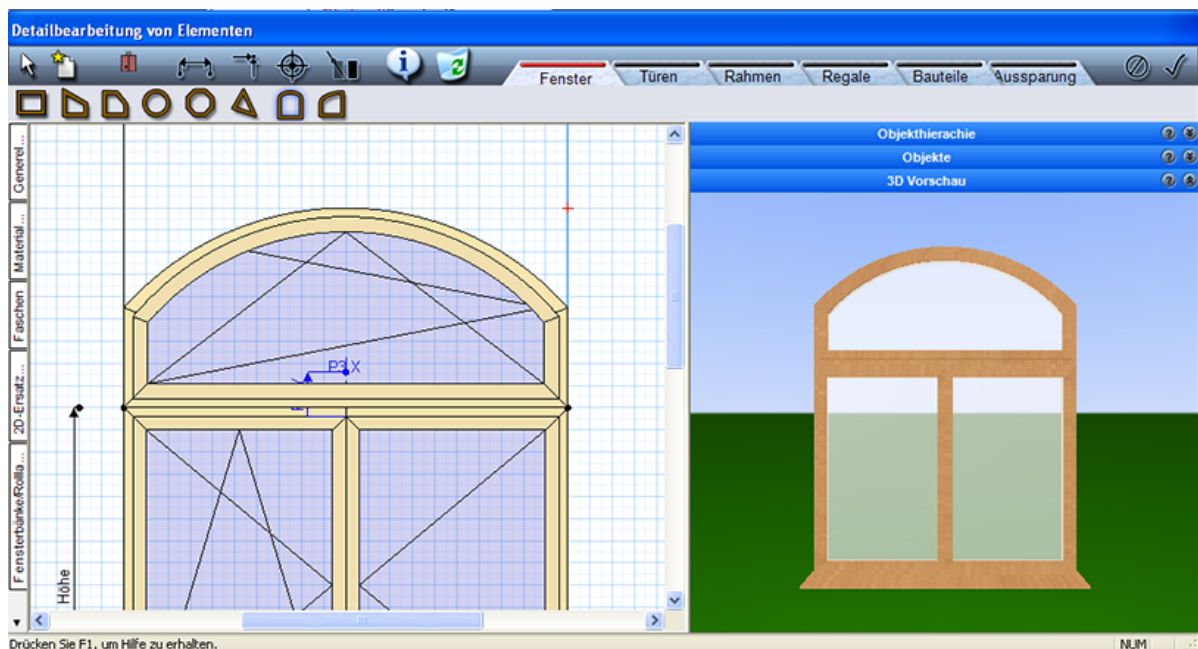

This is the round arch component that is to be generated in addition to the double-sash window. Activate the 'Round arch' component in the upper component bar, then start at the top left corner of the window (first click) and drag to the top right of the grid via a diagonal (small red cross - second click) then set the position of the arc vertex (third click)  
To modify the component, click once in the 2D view on the left-hand side of the slice with the left mouse button.

If the component is highlighted in red, a slider will appear on the right-hand side next to the 3D preview - please move it downwards, to access the settings for the window component:

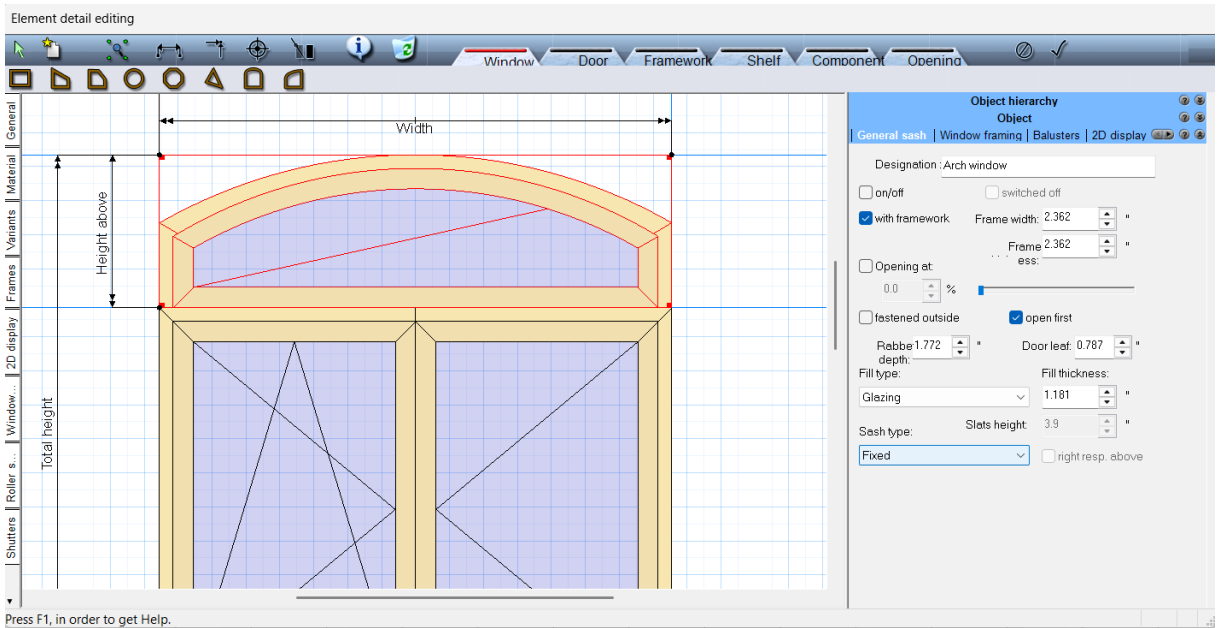

Below the 3D preview window, you will now find all the input options for the new component, broken down into tabs. Next to the tabs, you can use the small black triangle to scroll further until you reach the settings for specific sashes (round arch, triangular window, etc.), for example

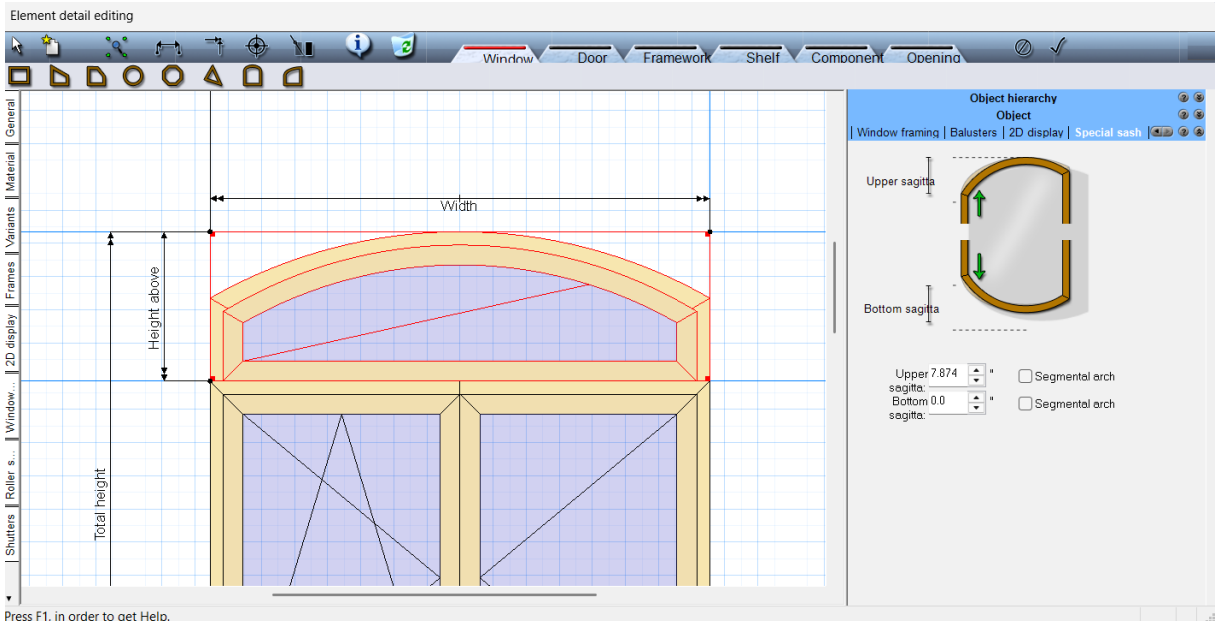

All setting changes are displayed immediately in 2D and 3D (for checking purposes)  
If you scroll back again with the small triangle, you can set the type of movement (fixed glazing), for example, under 'Sash general'.

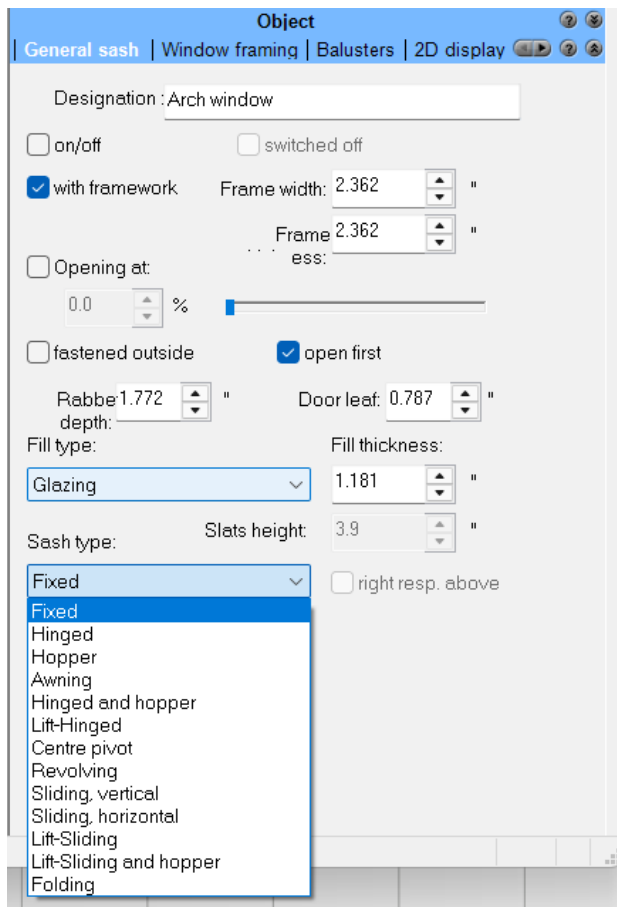

If only a frame is to be shown visually, the checkbox 'with framework' must be unchecked, then this component has no sash frame!

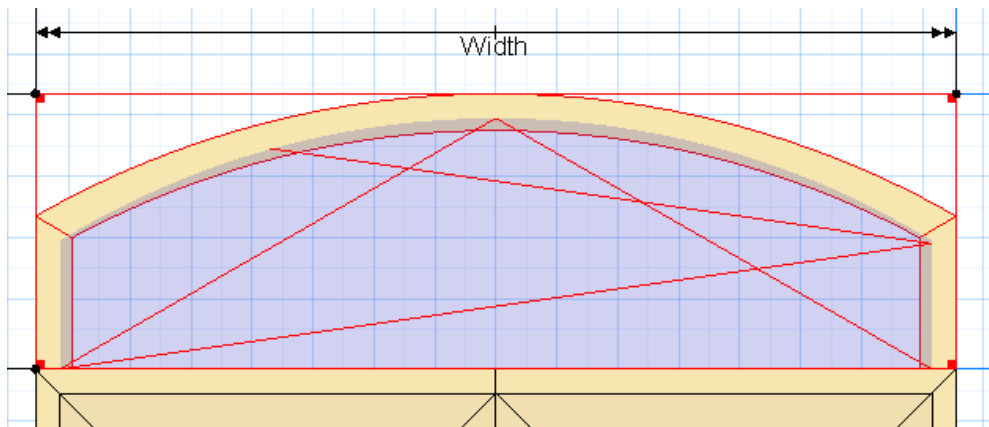

This means that any new window components can be created!

In order to be able to freely modify this window component at a later date, it is advisable to enter further additional dimensions. There is a function in the top bar above the window components:

'Insert additional dimension' , which allows you to add any number of additional dimension parameters to a window component.

Of course, the dimension must not result from another dimension entry! Likewise, an additional dimension cannot be set twice!

### 12.9.6.3 Georgian bars and Frame components

Each individual window component can be supplemented with additional muntin bars or frame components

#### Georgian bars:

Georgian bars are window components that can be assigned to the respective pane. To set these, the pane must be activated in the 2D view with a click (left mouse button), then move the slider on the right downwards and go to the Muntins tab. Click on 'with glazing bars'!

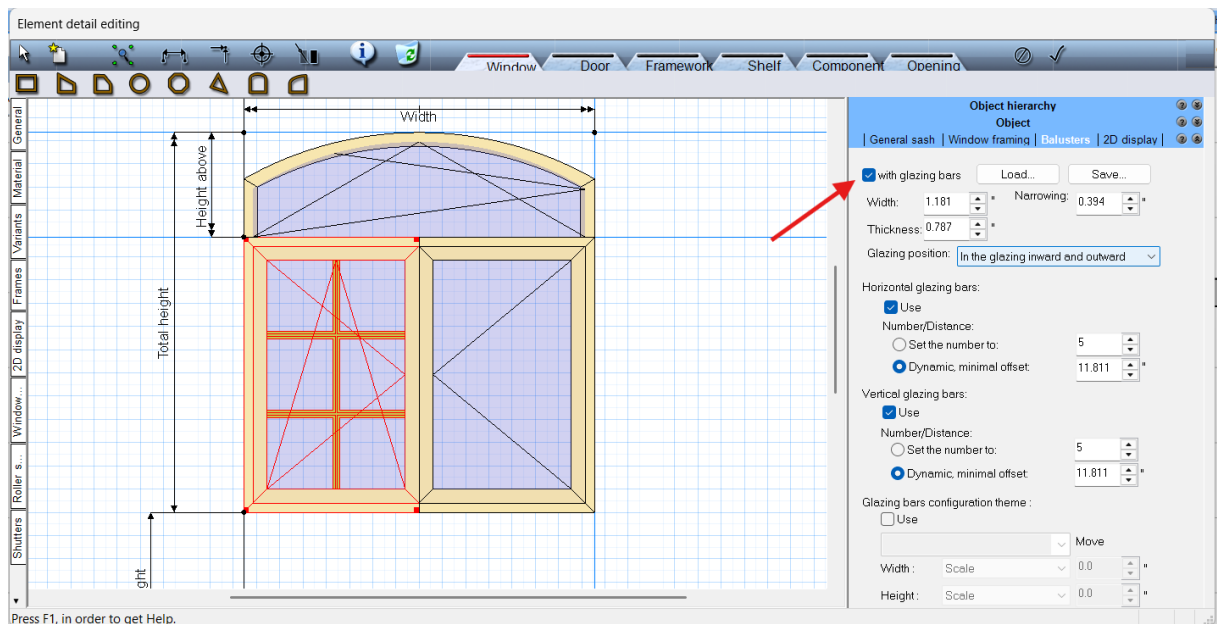

Set the width, thickness and taper. Then you can choose whether you want to have a fixed number - centered horizontally and vertically, whether the muntins should be dynamic with a fixed minimum distance (the number of muntins changes when the window component dimensions are changed), or whether you want to use a muntin image. If you want to use a muntin bar pattern, this option must be clicked and the checkboxes for horizontal and vertical muntins removed. After activating 'Use muntin bar image', you can select a suitable muntin bar image from the list below:

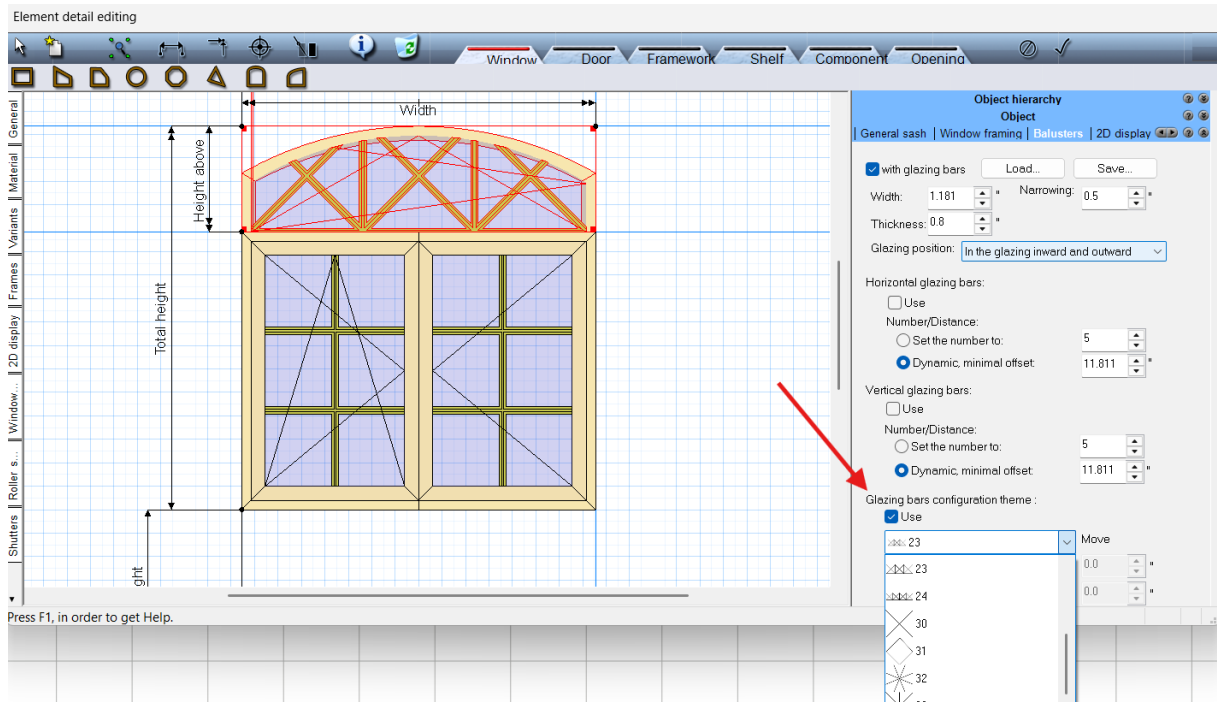

If the desired muntin bar image is not available, a new muntin bar image is created and saved as follows:

- \* create a new drawing
- \* Open the muntin bar images folder under Symbols
- \* Drag a similar muntin bar image into the planning
- \* click on this muntin bar image in the middle and ungroup it
- \* then remove superfluous lines
- \* Draw new lines
- \* extend the new lines via the 'Extend' container at the beginning or end (as appropriate)
- \* group everything and place it in the symbol folder 'rung pictures'
- \* after restarting this muntin image can be used

### Frame components:

These components can be attached to the window as required. They are independent components with variable dimensions. In order to set a frame component correctly, the starting point and the end point must be precisely defined beforehand.

This correct definition can be made using a grid point, by setting **element snap points**:  or by

setting **additional point dimensions**: .

These are set in relation to a definable point and correctly determined using x and y coordinates:

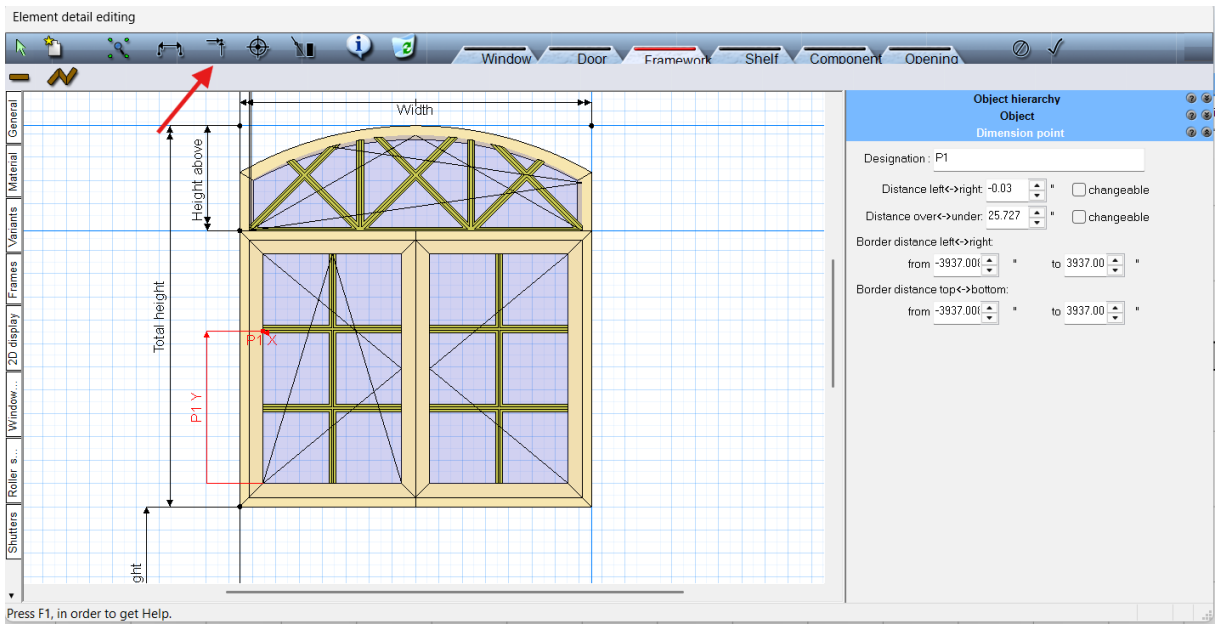

Once the important points have been defined, the 'Frame' mode can be activated:

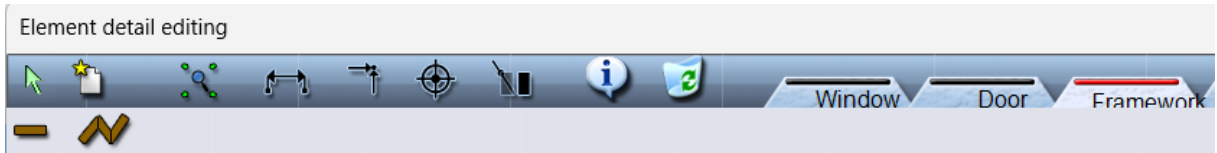

A frame can be entered as a single component or as a polygon (for example, surrounding the window). Select the corresponding function and set the frame component. Once the frame has been set, it can be activated in the 2D preview and defined accordingly in the 3D preview (slider downwards):

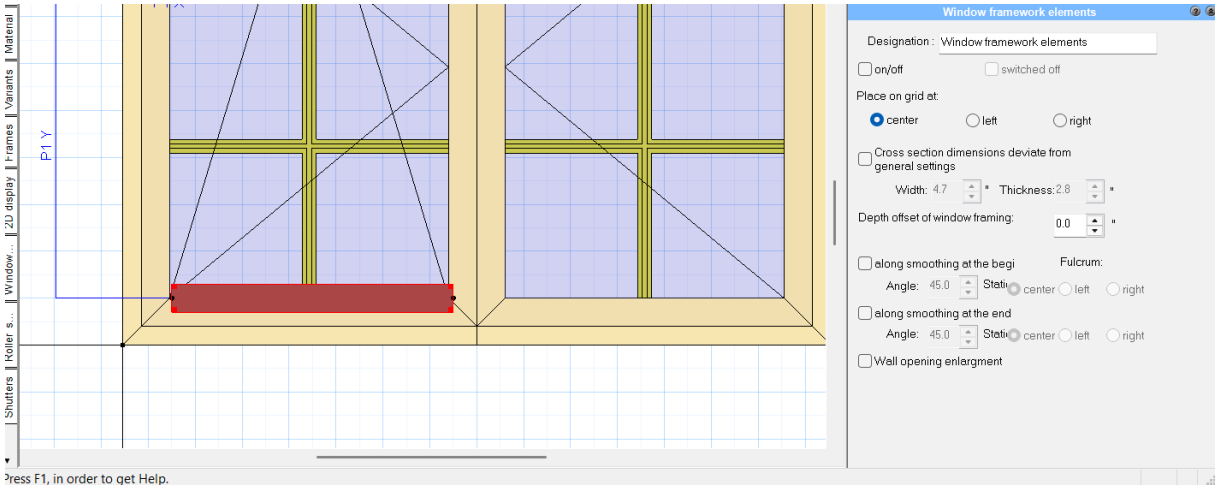

All changes and settings are immediately visible in the 2D and 3D preview!

If the frame component is used to widen the frame (e.g. above the window as a roller shutter box), an option can be set to enlarge the wall opening:

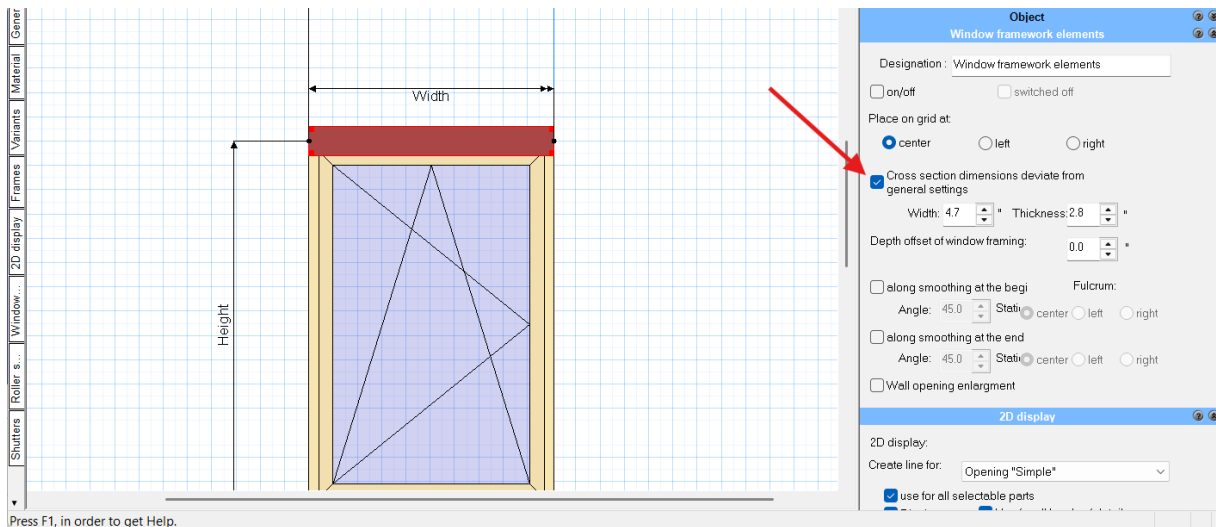

#### 12.9.6.4 Placing objects at the window

Any number of objects can be placed on the window. These then belong to the window and are taken into account when the window is moved!

Window objects are, for example, window handles, shutters, curtains, stucco elements and much more. The positioning of objects is explained using window handles as an example:

As already described for the frame components, the fixed position must be precisely defined by an **object snap point**, or by a **point - additional dimension**. Now open the object folder above the 3D preview on the right and select the folder 'Fittings' and from there the desired fitting

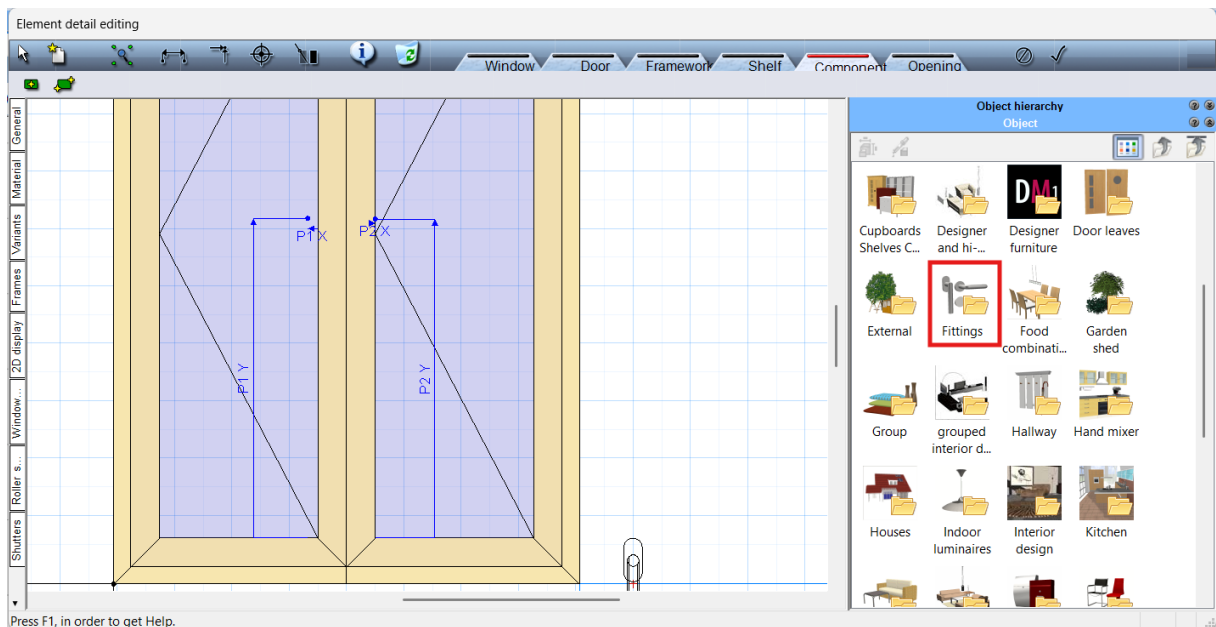

Now select the mode: **'Components'** and activate the function for how you want to set this object:

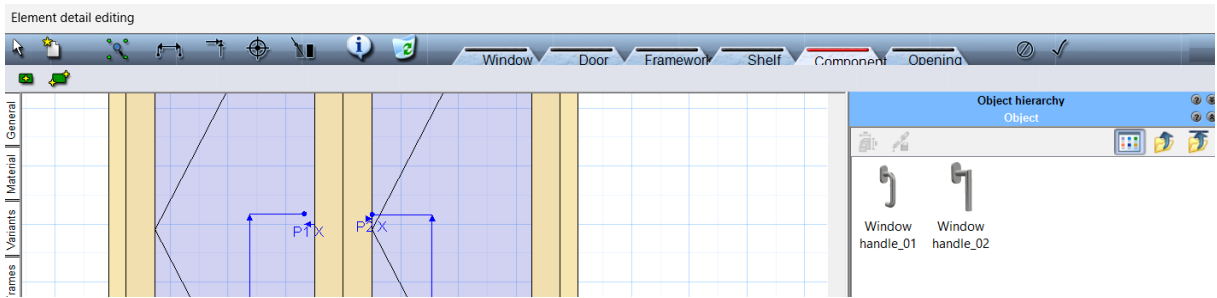

and click on the previously defined insertion point.  
Once the object has been set, it can be activated again in the 2D preview (then turns red) and defined on the right-hand side under the 3D preview.  
In the 2D view, we always see the inside view of the window. If the object is to be positioned on the outside of the window, this can be specified in the settings. Objects can be moved in relation to the window at any time using the previously defined additional point dimension!  
All objects that are in the database in can also be used for the windows:

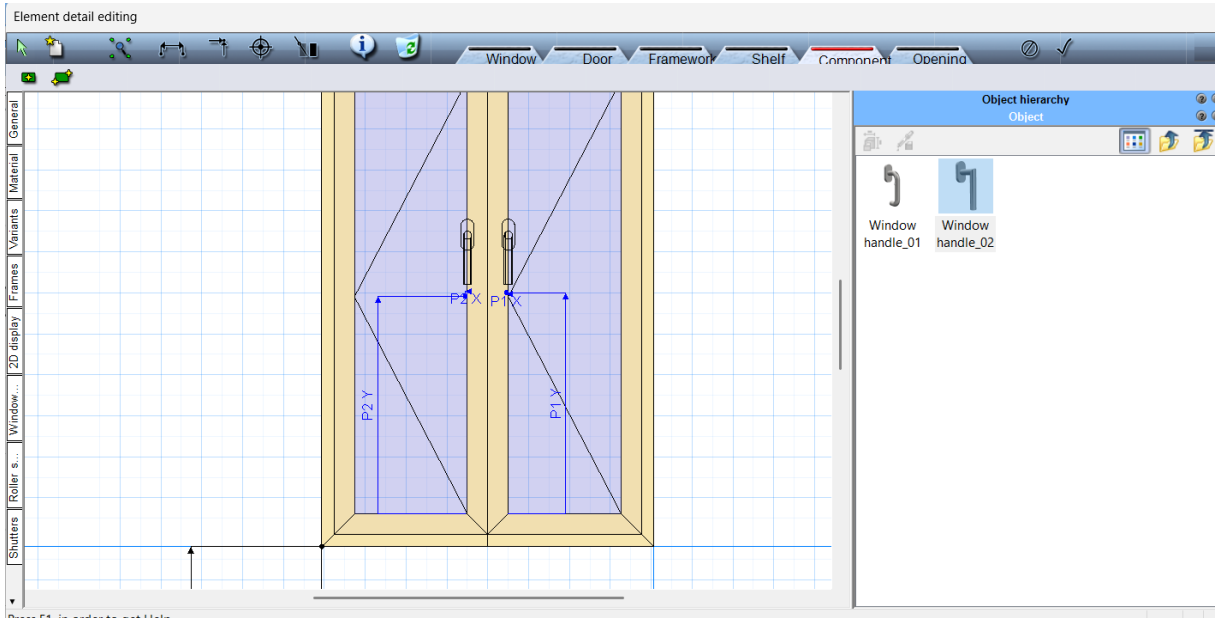

Once all settings on the window have been completed, they are confirmed by activating this function:  and can be viewed in the floor plan or in 3D:



#### 12.9.6.5 Door-window combinations

As already mentioned at the beginning, the components are defined in <%SOFTWARE%>: Windows, doors and wall openings are defined in the same way. It is therefore also possible to define doors and windows together without any problems.

##### **Doors:**

For exterior and interior doors, we have a wide variety of components from the catalog available in Plan7Architect. If you want to define a door that is as free as possible, you should select the door with interchangeable door leaves. To change or extend these, you can access the advanced editing function again via the component after activating the door.

If changes are to be made, the door leaf can be clicked on in the 2D preview and edited in the 3D preview as already described for the windows.

If the door leaf needs to be replaced by another one, open the object folder above the 3D preview and select the 'Door leaves' folder

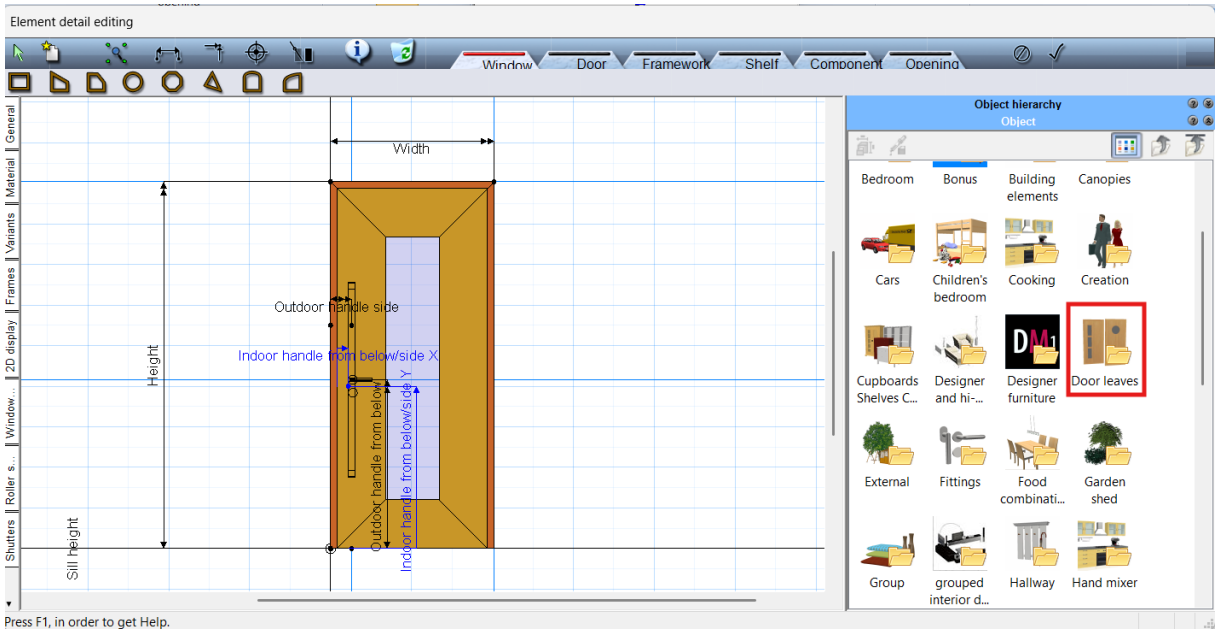

In this folder you will then find all the door leaves that can be replaced. The desired object must be activated. To be able to replace it, select a different door panel once in the door panel setting under 'Type of panel' and then click on 'Current object as door panel' again and the door panel has been replaced:

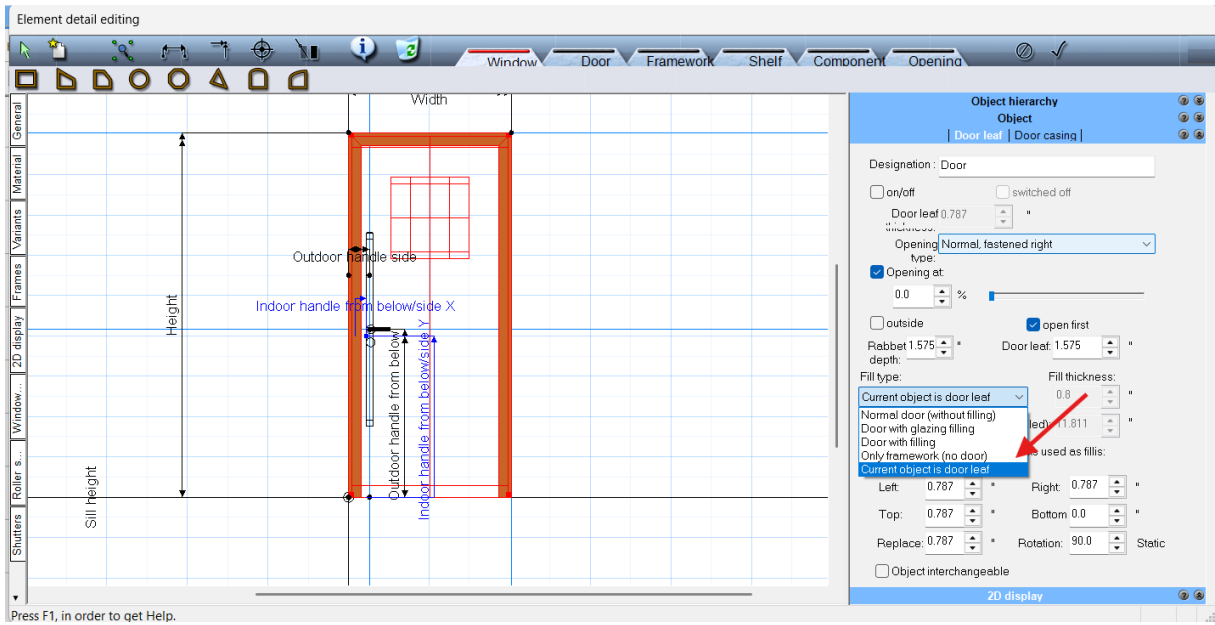

If the door is to be extended with window elements, these are added in 'Window' mode, as already described for windows and defined accordingly:

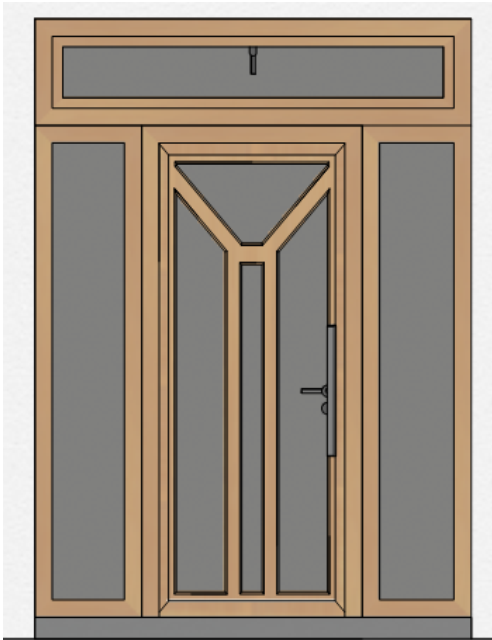

Of course, each new combination can be stored under its own name in the corresponding component catalog. This means that the new component can be used in all projects.

## 12.10 Roofs

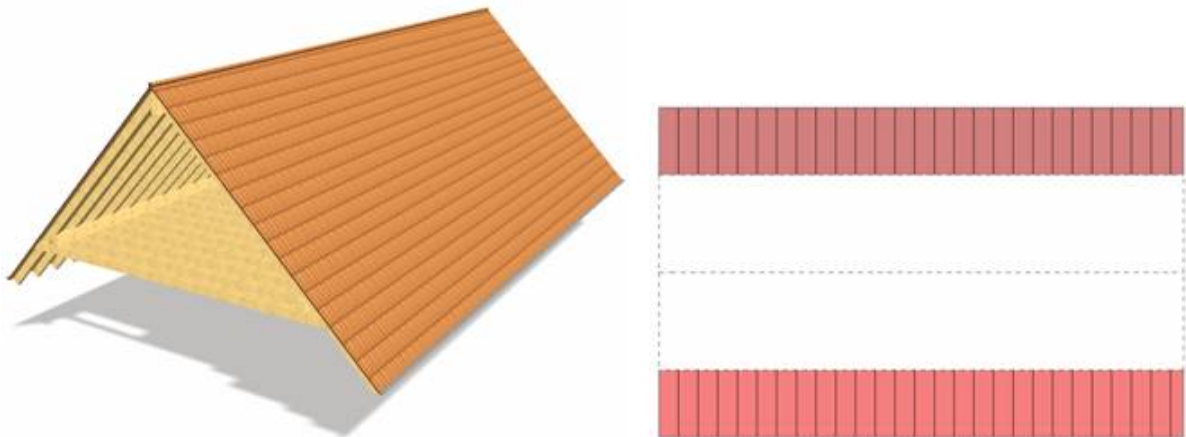

### 12.10.1 General information

A roof is entered using a polygon. Each side of this roof polygon creates a roof surface. The roof side type can be defined for each roof surface, for example hip side or gable.

Depending on the type, the corresponding parameters are offered, such as the height, overhang and roof pitch for a hip side.

The display of roofs in the floor plan is influenced by the 2D display settings. A section height is specified for the 2D representation. The height is always determined in relation to the current storey.

In 3D mode, a roof consists of the covering, the outer construction and the timber construction (if visible) as well as details such as ridge tiles or guttering.

The construction of the roof is shown as a roof slope in each room that is

- is bounded by the roof
- should also show sloping roofs (in the dialog *levels* of the room)

The timber construction is independent of the construction thickness. The position of the rafters in relation to the roof pitch is variable.

The construction of roofs, especially with regard to the correct roof determination, is easier to check if the 3D preview is displayed during the modification of the roof or is switched to 3D mode.

The roof surfaces can also be selected in the preview in order to change the parameters.

The new **editing mode specifically for roofs** switches to a separate mode with special functions for roof editing.

## 12.10.2 Drawing

Roofs are always stored on the **Roofs** layer. This assignment can not be changed.

Click on the **Roofs** button  in **Construction** mode.

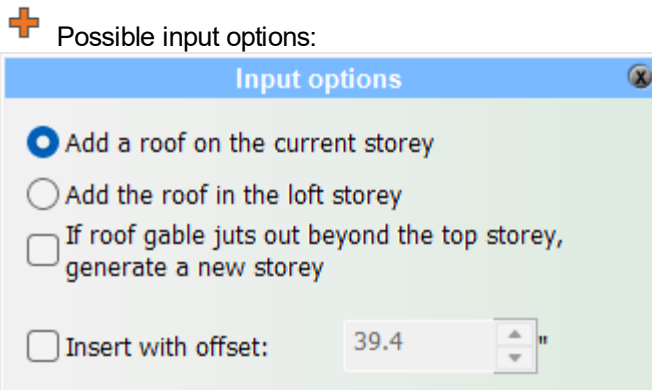

**Add the roof in the current storey** - the roof is created on the current storey

**Insert roof in attic** - the roof is optionally always inserted in the attic; if the storey does not yet exist, it is newly created with the options specified here for the transfer of walls, windows etc.

**Enter with offset** - the roof is constructed parallel to the input points with offset.

Select the desired [input type](#) <sup>331</sup> before drawing the roof.

### 12.10.2.1 Input types

- You will find all the options for drawing a roof under the selection bar:



- **Automatic contour recognition** 

Required input: 1 point

The contour of the roof is determined automatically. Please ensure that the outer walls are cut correctly.

- **Polygon** 

Required input: n points

The roof is entered using any number of corner points. End the input by selecting **[Esc]** or via the context menu **Finish element**.

- **Rectangle** 

Required input: 2 points

The roof is entered using two diagonally opposite corner points.

- **Rotated rectangle** 

Required input: 3 points

First define one side of the rectangle with two points. The height of the rectangle is defined with the third point.

- **Polygon with fixed width** 

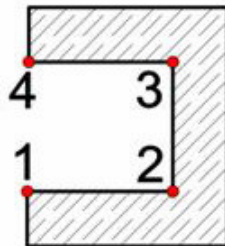

Required input: n points

The roof is entered using any number of corner points. The result is a "band" of the set width with a closed contour.

### 12.10.3 Property dialogs

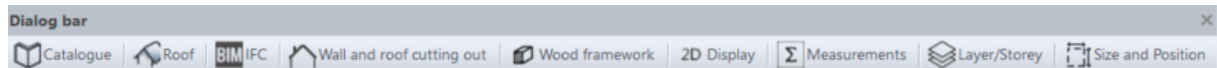

#### 12.10.3.1 Catalogue

Component templates are offered in the catalogue. If you select a component template, all parameters of the roof are adjusted. Further information on [catalogues](#)<sup>150</sup> can be found in the [General properties dialogues](#)<sup>134</sup> chapter.

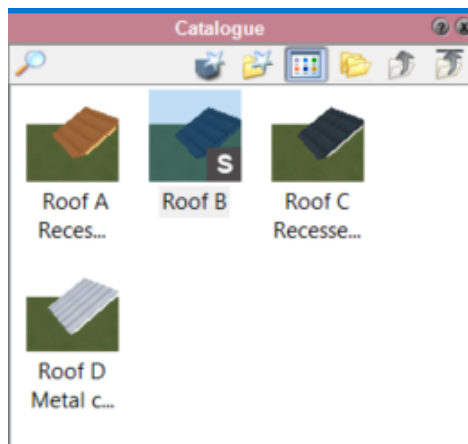

The type of roof is not saved (such as saddle, crippled hip or flat roof) but the settings for the timber construction, the roof structure and the standard setting for the roof side.

### 12.10.3.2 Roof

#### 12.10.3.2.1 General

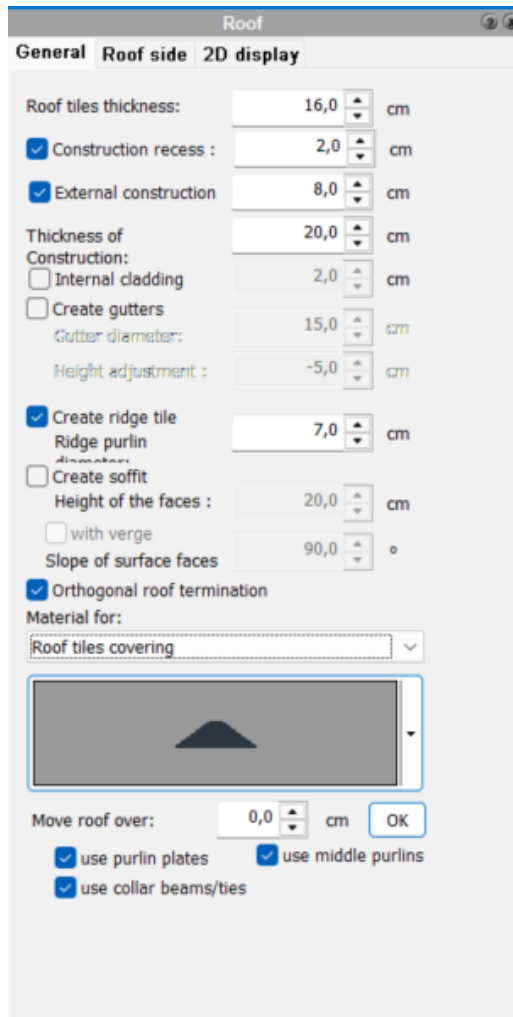

The dialogue **Roof|General**

Optionally, **gutters** and **ridge tiles** can be created for the roof along all eaves (horizontal roof edges) . The radius can be set in each case.

The height of the gutters can be changed with the **Height above the top edge of the roof storey** option.

The **material** can be defined separately for the following areas:

- Roof covering
- underside of the roof (of the covering, not the structure)
- Roof edges of the covering
- Gutters and ridge tiles

Click on the preview image to change the material or on the selection button ▾ to access the templates. Of course, the material can also be changed in 3D mode using drag & drop from the catalogue.

The **Create cornice boxes** option allows you to place cornice boxes on eaves and optionally on gables. Enter the dimensions in the corresponding fields.

The **Move roof by** function is used for roofs that have already been drawn to move the entire roof by the set value. The function is executed by clicking **OK**.

The purlins and collar beams are also optionally moved in height.

#### 12.10.3.2.2 Roof side

The settings for a roof side are defined in this dialogue. To do this, select the roof side in the top graphic.

The 3D preview can be displayed while the roof is being edited.

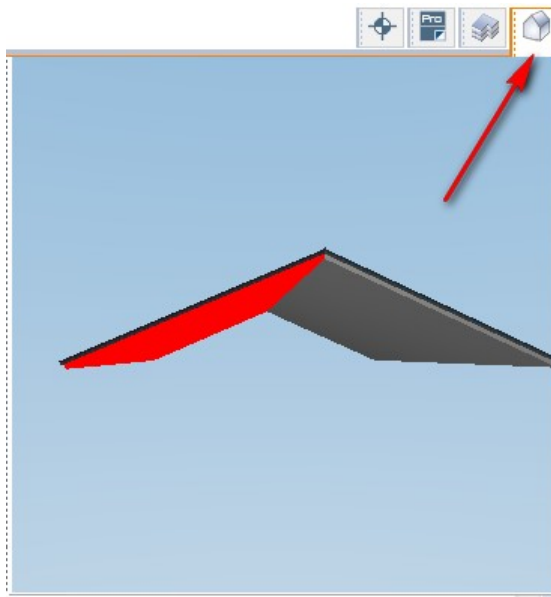

The roof side to be edited can also be selected in the 3D preview window. Alternatively, switch to 3D mode.

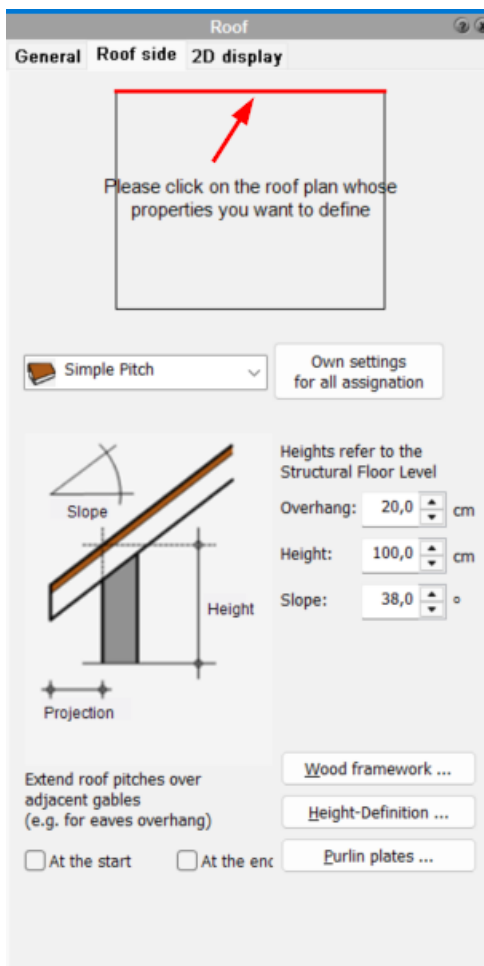

Select the type of roof surface in this list.

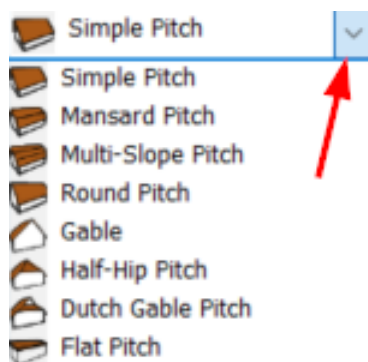

**Wood framework:** It is possible to set different heights for the base purlin or centre purlin here. A second centre purlin can also be defined.

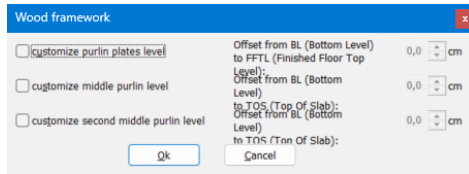

### **Height definition, base purlin**

see below:

### **Height definition**

In this dialogue, you can enter and define the height of the knee height inside and outside as well as the eaves height.

The values can be entered either **from the finished floor**, **from the unfinished floor** or **in absolute terms**.

The wall thickness (**distance**) must be entered for the inner dimension of the knee wall.

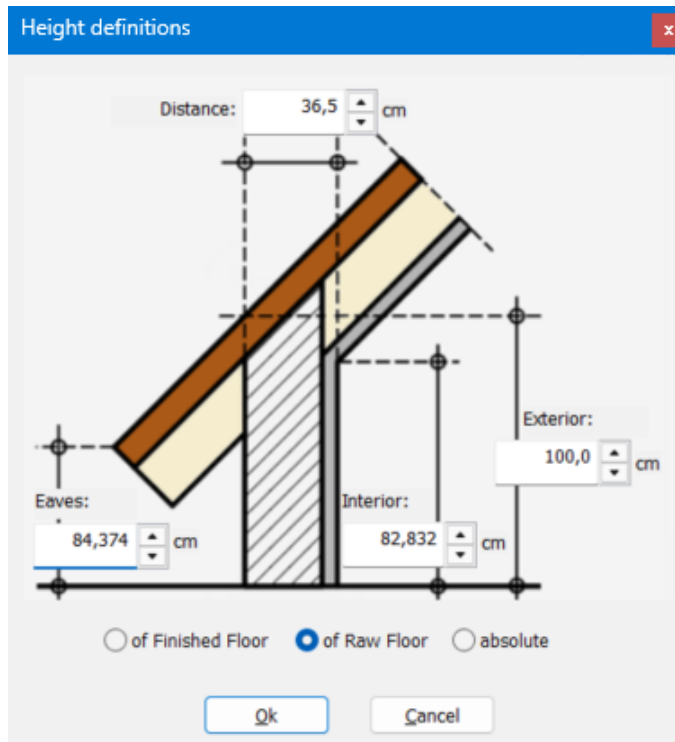

### **Purlin**

In this dialogue, the height of the roof side can be entered via the parameters of the purlin.

The width and height are taken from the cross-section dimensions from the dialogue Timber construction of the roof.

Also enter the support height (from the finished floor FFB, from the unfinished floor RFB or as an absolute value), the distance of the purlin from the outer edge (actually from the roof contour entered) and the value of the upstand timber. The height of the eaves height is determined automatically.

Optionally, the changes can also be applied to all other roof surfaces (only the difference) as well as to the centre purlins and collar beam position of the roof.

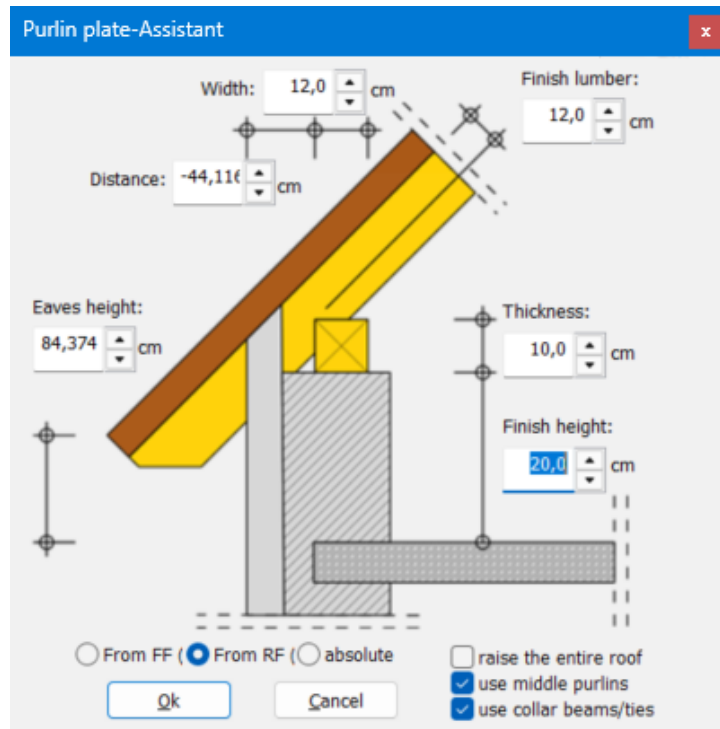

## 12.10.3.2.3 2D representation

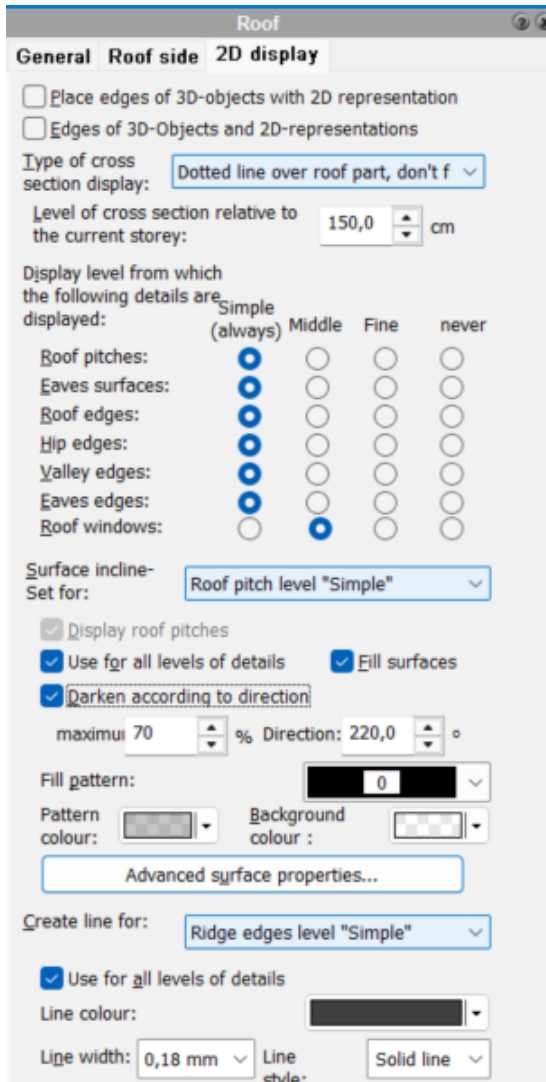

The 2D replacement display can be set separately for each roof.

First select whether the roof is to be displayed in section and which part of the roof is visible.

The section height of the roof is determined on the basis of the current storey. A roof on the ground floor, e.g. a canopy, is at a height of 2 metres. If a cutting height of 1 metre is set, the roof on the ground floor appears completely dashed, on the upper floor you see the top view.

The visibility can be selected for each edge type according to the level of detail. The current level of detail is selected in the **View** menu.

Filling and hatching can be set for all roof surfaces, and line type and colour can be set for all roof edges. This is done depending on the level of detail or for all levels of detail together.

Level of detail options:

- Roof pitch level "Simple" ▾
- Roof pitch level "Simple"
- Roof pitch level "Middle"
- Roof pitch level "Fine"
- Eaves surface level "Simple"
- Eaves surface level "Middle"
- Eaves surface level "Fine"

12.10.3.3 Wall and roof intersection

Under this menu item, you can select which roof should intersect with the active roof

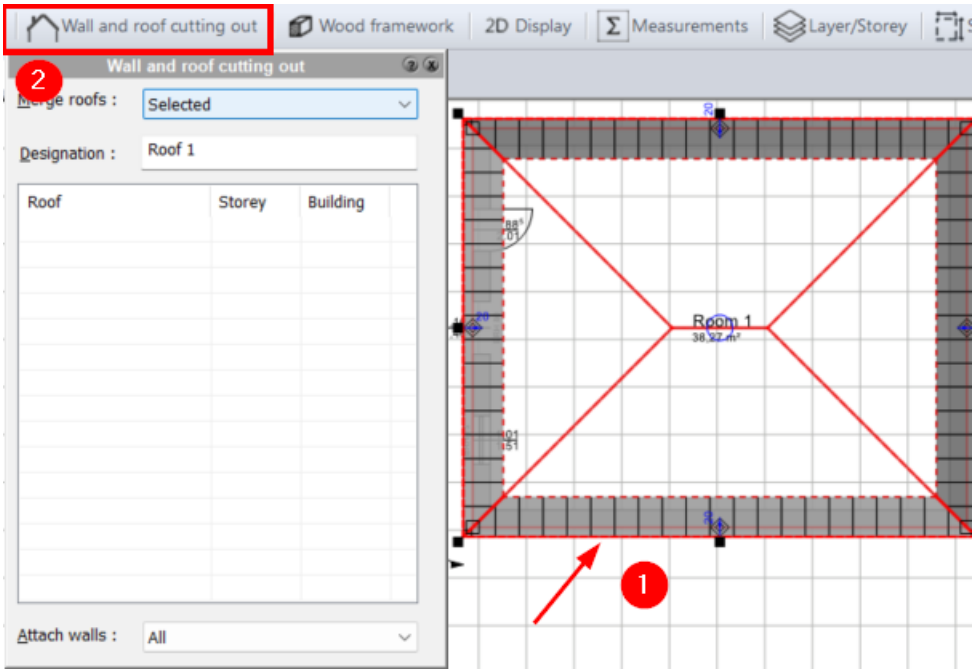

### 12.10.3.4 Wooden construction

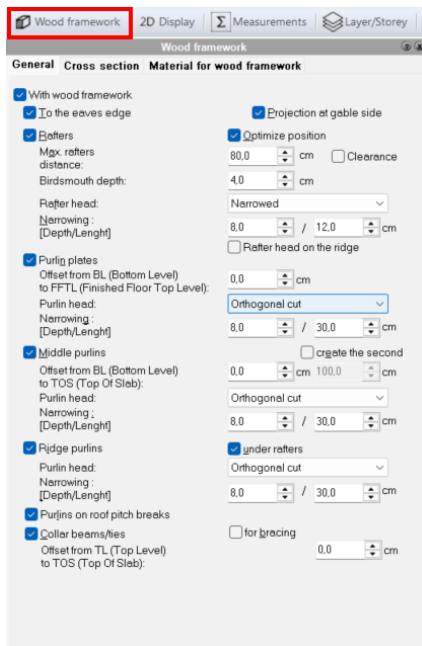

With the option **up to the eaves edge**, the rafters are led up to the eaves edge.

The **Overhang on gable ends** option means that the timber construction on the gable ends of the roof is also shown outside the roof polygon (normally the outer edge of the wall).

The option **Rafter heads** also on ridge shows the formation of the rafters also on ridges of monopitch roofs. (i.e. on roof surfaces with ridges that are not adjacent to any other roof surface).

Which **roof timbers** are created can be defined with the respective option.

The height of the base purlins and middle purlins can be changed in relation to the upper edge of the floor and upper edge of the bare ceiling.

The **height of the ridge purlin** is determined by the roof calculation.

However, the detailed design of the ridge can be changed with the option **under rafters**.

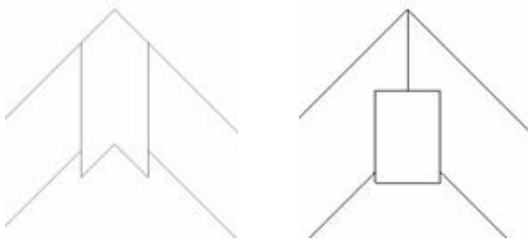

**unter Sparren** aktiv nicht aktiv

### 12.10.3.5 Machining wooden structures

Switch the visibility of the timber construction to **exclusive** in the **View** menu.

Move an entire container: Left-click on the bundle, hold down the button and move the bundle to the desired position.

The following can still be edited:

- Rafters by moving, deleting and copying
- Collar beam by deleting

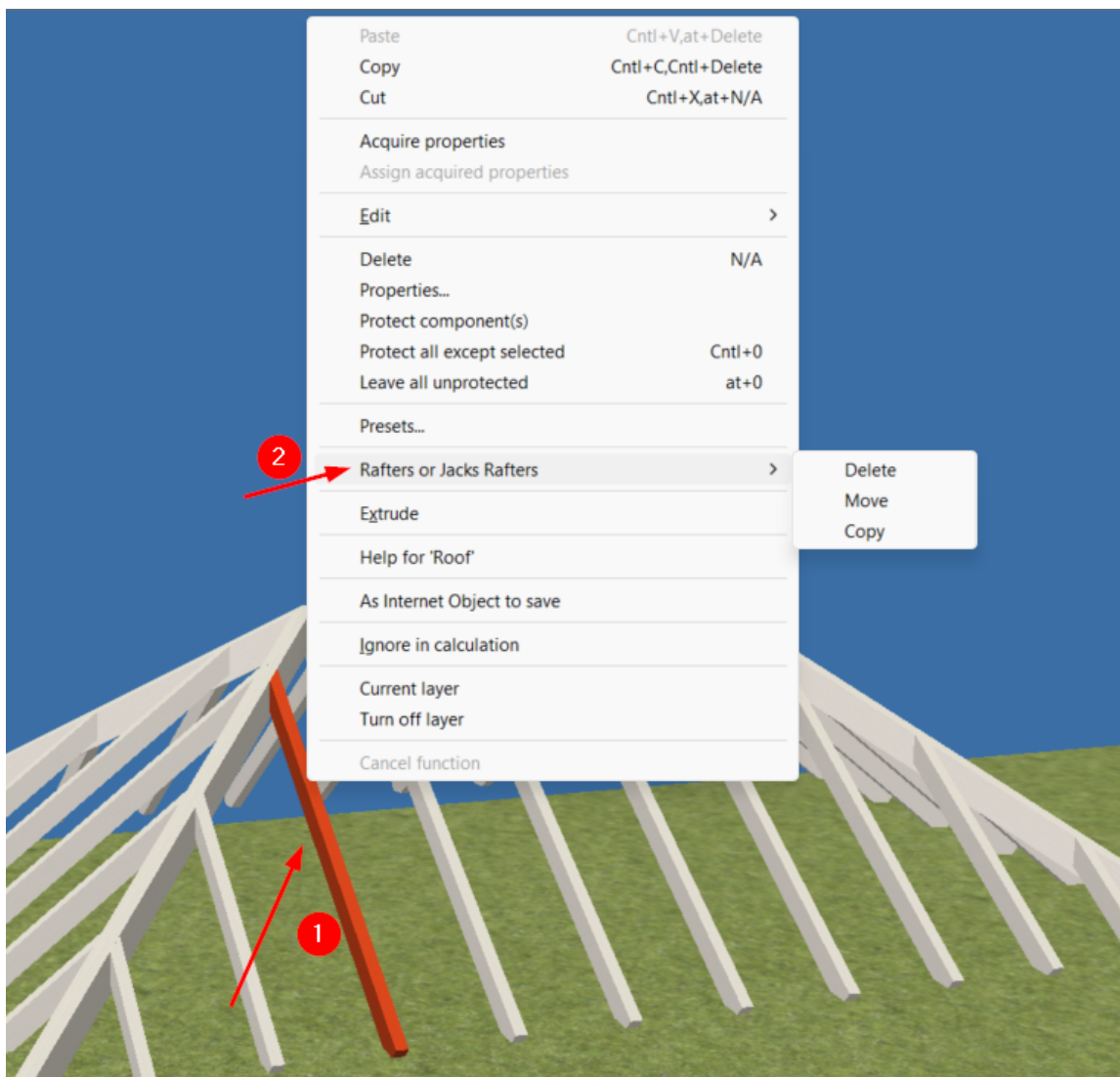

Right-click on the corresponding beam (floor plan or 3D view). You will see an entry with the name of the beam in the context menu and the selection of the editing function in the submenu.

If a rafter is moved, the opposite rafter is also moved (a pair of rafters that meet at a ridge). The height of the collar beams is determined by the height of the storey ceiling.

### 12.10.3.6 Fill/Hatching/Contour

Further information on the [layer/floor](#)<sup>[143]</sup>, [size/position](#)<sup>[143]</sup>, [contour](#)<sup>[138]</sup>, [fill](#)<sup>[140]</sup> and [hatching](#)<sup>[141]</sup>, [surface](#)<sup>[145]</sup>, [masses](#), [PosNr](#)<sup>[263]</sup> and properties can be found in the chapter [General properties dialogs](#)<sup>[134]</sup>.

### 12.10.4 Roof editing mode

In the new **editing mode for roofs**, various settings, changes and extensions can be made very elegantly.

If a roof is **selected** in the planning, you can access the editing **mode** via this button .

In this mode, there are special functions that are used exclusively for editing the roof.

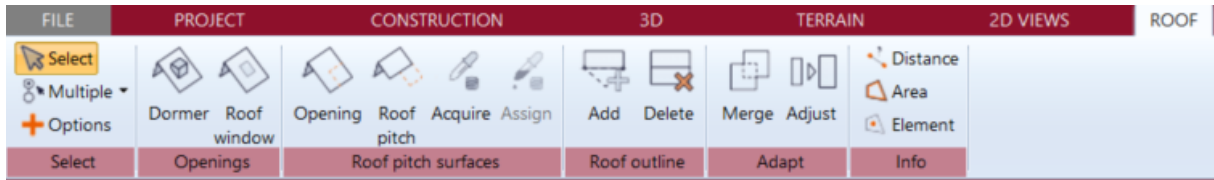

### 12.10.4.1 Editing the roof sides

In edit mode, the information for all roof sides is displayed for

**pitch**  
**overhang**  
**jamb height**

and the height of the ridge

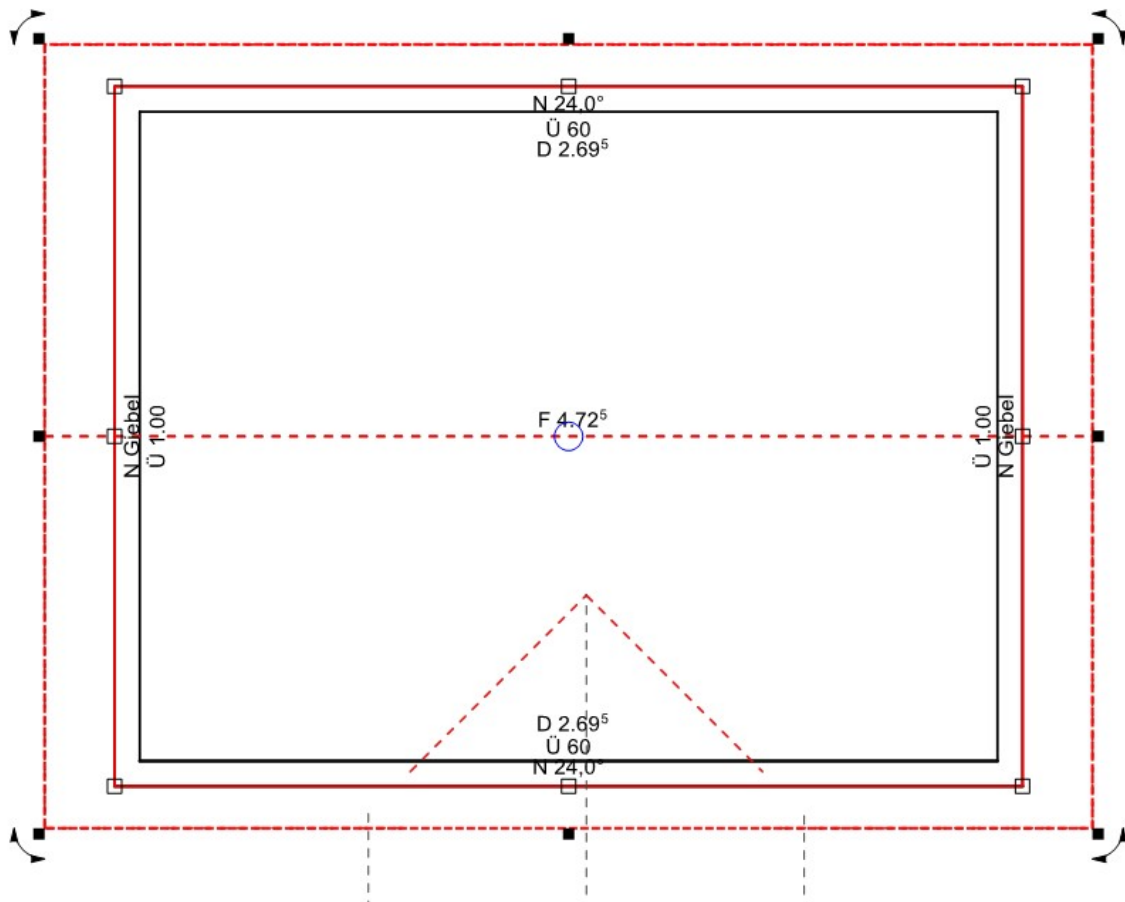

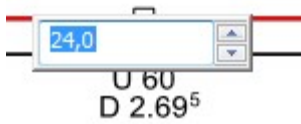

By clicking on the number in each case, the online dimension input appears for changing:

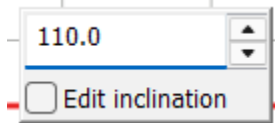

and, for example, the roof pitch can be changed directly by clicking on it (**online dimensions**).

When changing the ridge height, there is an option to change the pitch or to raise the roof.



These values for the roof sides can be transferred to other roof sides using the pipette  **Accessing roof side properties**

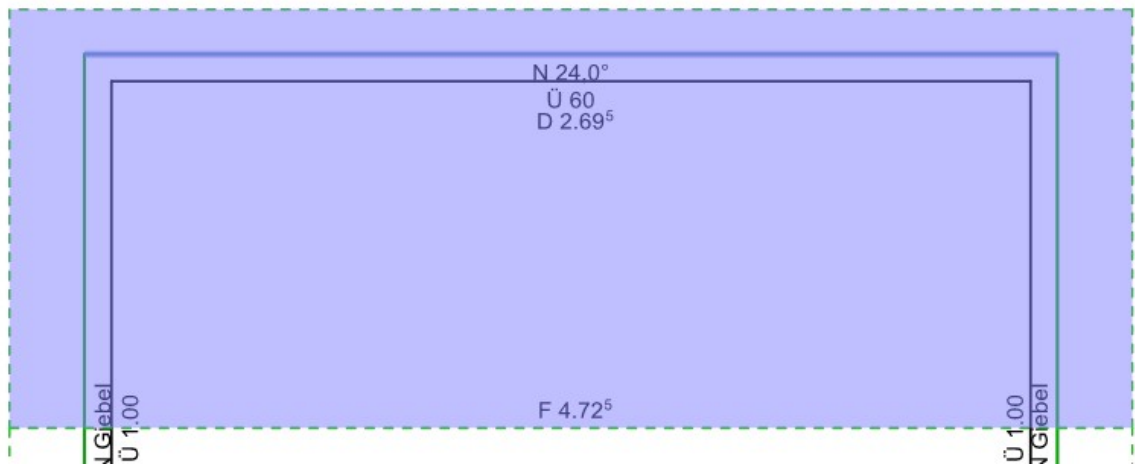

#### 12.10.4.2 Roof openings and roof side extensions

Any **roof openings** can be entered in the **editing mode for roofs**

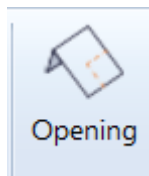

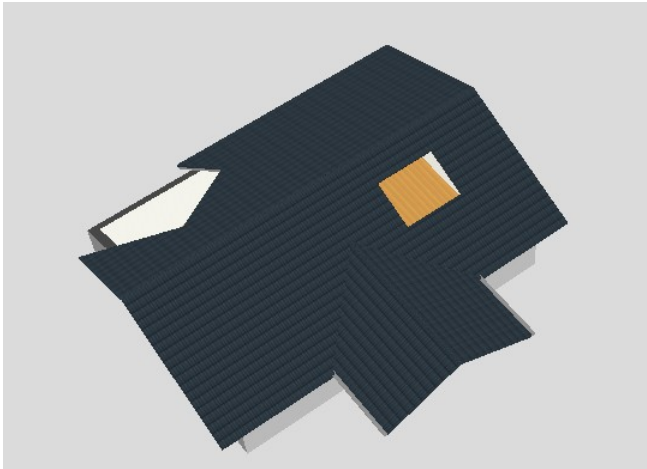
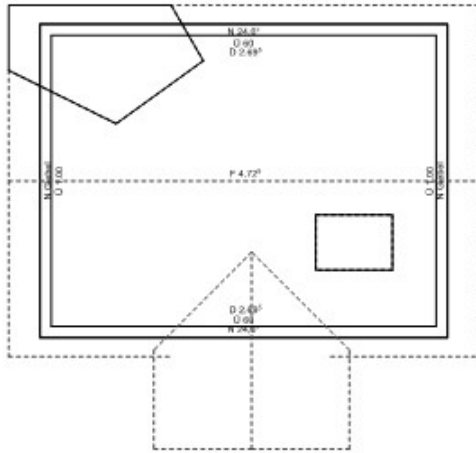

The **roof side extension** component is available for roof extensions:

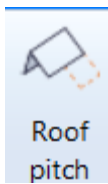

Select roof area:

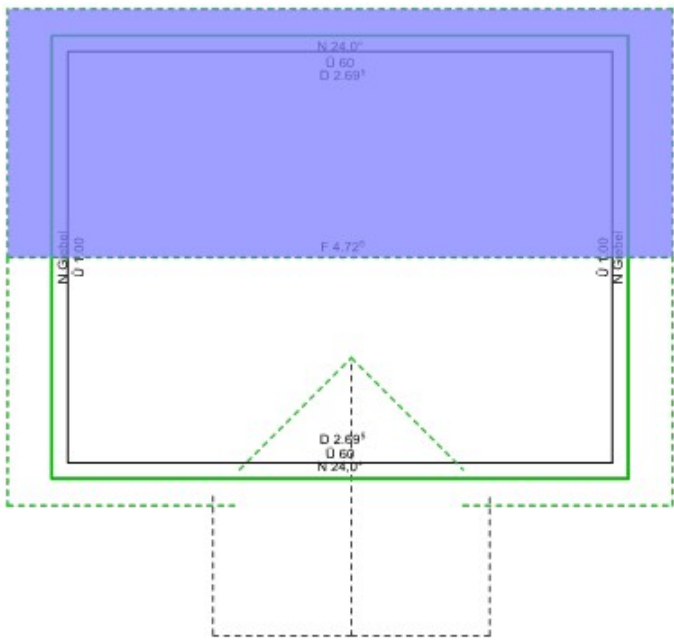

and draw extension/slope:

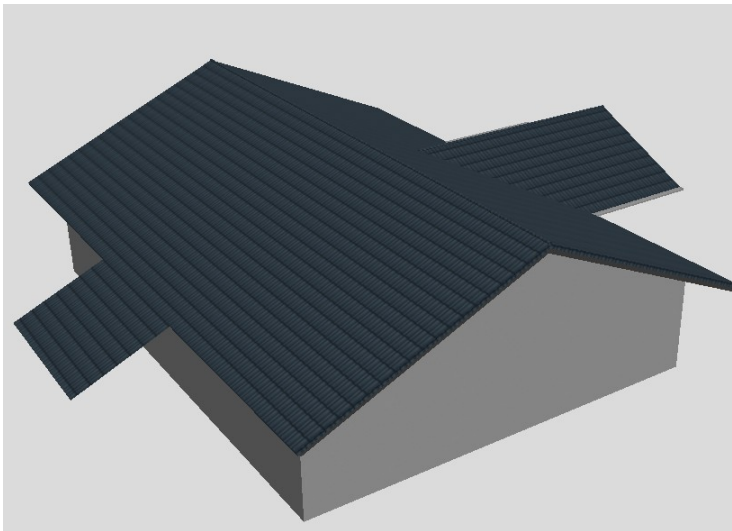
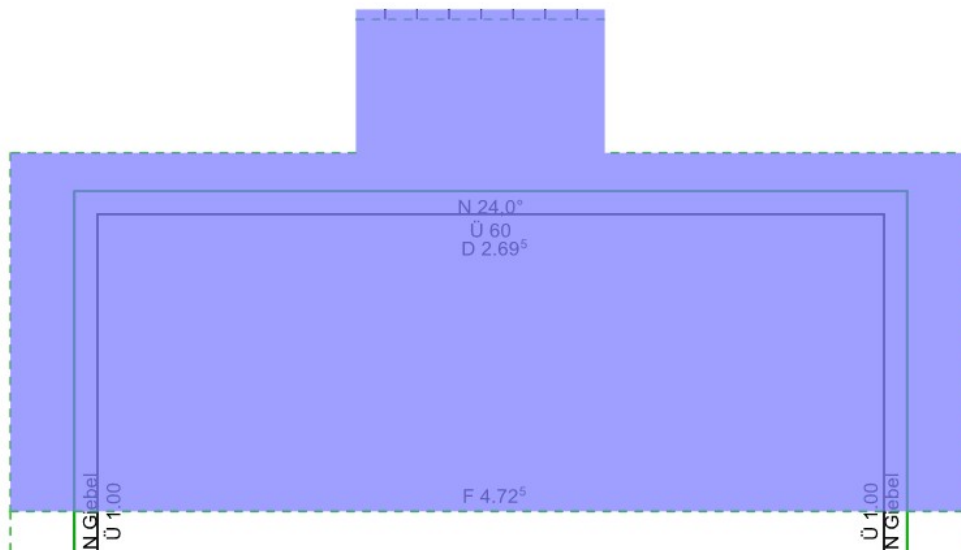

### 12.10.5 Blending roofs

Under the menu item **Project|Intersect roofs**, you can select which roofs are to be intersected:

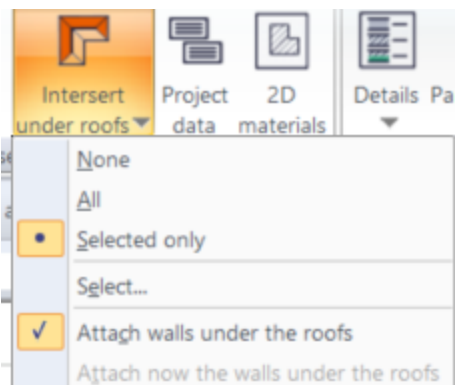

This function makes it much easier to design complex roofs, as each roof section can be drawn separately as a roof. The final roof is created from the intersected individual roofs.

## 12.11 Dormer windows



### 12.11.1 Drawing

Click on the **Dormers** button in **Construction** mode.

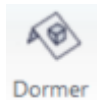

You can only create a dormer if you have previously constructed a roof area. The roof and dormer are in a corresponding relationship to each other. This means that when you enter a dormer, the system recognizes which roof surface is present and how the orientation of the eaves edge relates to this surface. This automatically ensures that the front edge of the dormer is always positioned parallel to the eaves edge of the roof when the dormer is installed.

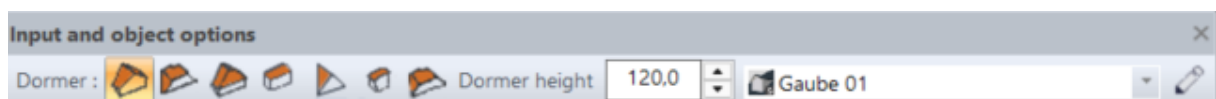

#### Types of dormers:

- Saddleback dormer
- Bat dormer
- Hipped dormer
- Trailing dormer
- Pointed dormer
- Barrel dormer
- Trapezoidal dormer

Terrace

## 12.11.2 Property dialogs

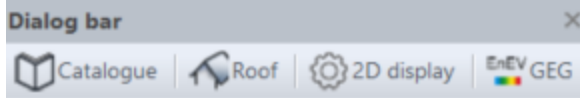

### 12.11.2.1 Catalogue

Component templates are offered in the catalog. If you select a component template, all parameters of the dormer are adjusted. Further information on the [catalogs](#)<sup>[150]</sup> can be found in the [General properties dialogs](#)<sup>[134]</sup> chapter.

### 12.11.2.2 Fill/Hatching/Contour

Further information on the properties [Contour](#)<sup>[138]</sup>, [Fill](#)<sup>[140]</sup> and [Hatching](#)<sup>[141]</sup>, [Masses](#), [PosNr](#)<sup>[263]</sup> and [properties](#) can be found in the chapter [General properties dialogues](#)<sup>[134]</sup>.

## 12.12 Roof windows

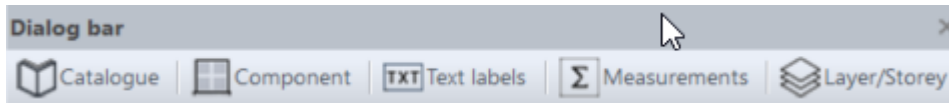

### 12.12.1 Drawing

Roof windows can be inserted into existing roofs.

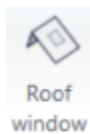

After selecting the command, the roof surface is selected at the eaves edge and the skylight is placed

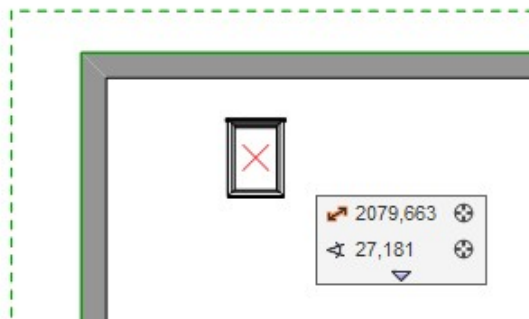

A label for the window can be displayed:

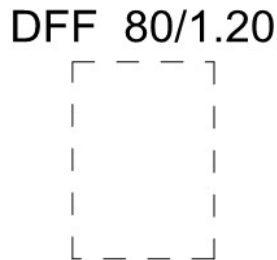

### 12.12.2 The overview bar



The roof window type, width and height are defined in the overview bar.

Options:

**Swap right and left for the skylight:**



**Swap front and rear for the skylight:**



### 12.12.3 Property dialogs

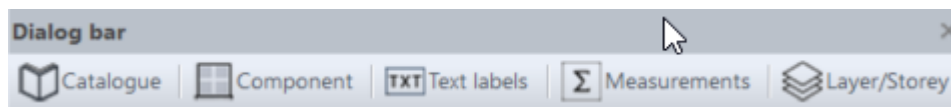

Further information on the properties [Labelling](#)<sup>[204]</sup>, [Properties](#), [Masses](#), [Layer/floor](#)<sup>[143]</sup> and [PosNr](#)<sup>[263]</sup> can be found in the chapter [General properties dialogues](#)<sup>[134]</sup>.

#### 12.12.3.1 Catalogue

Component templates are offered in the catalog. If you select a component template, all parameters of the roof are adjusted. Further information on [catalogs](#)<sup>[150]</sup> can be found in the [General properties dialogues](#)<sup>[134]</sup> chapter.

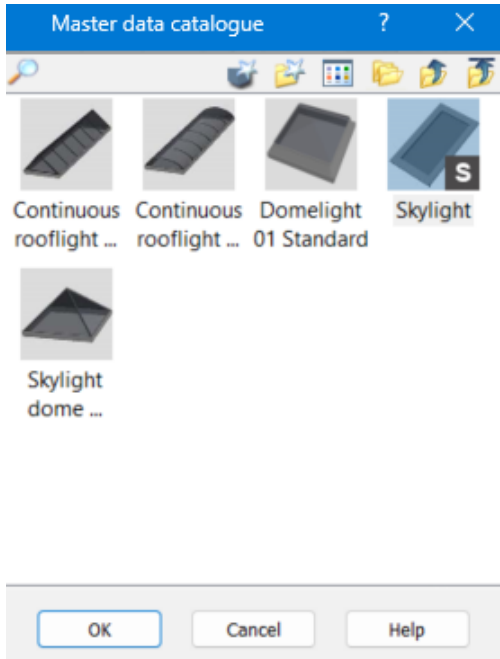
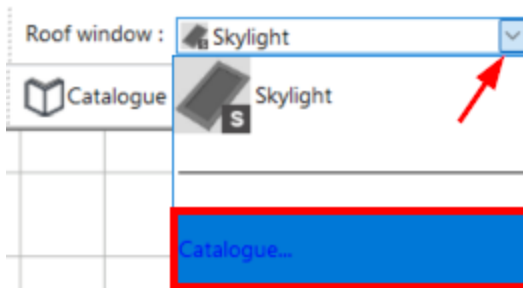

### 12.12.3.2 Component

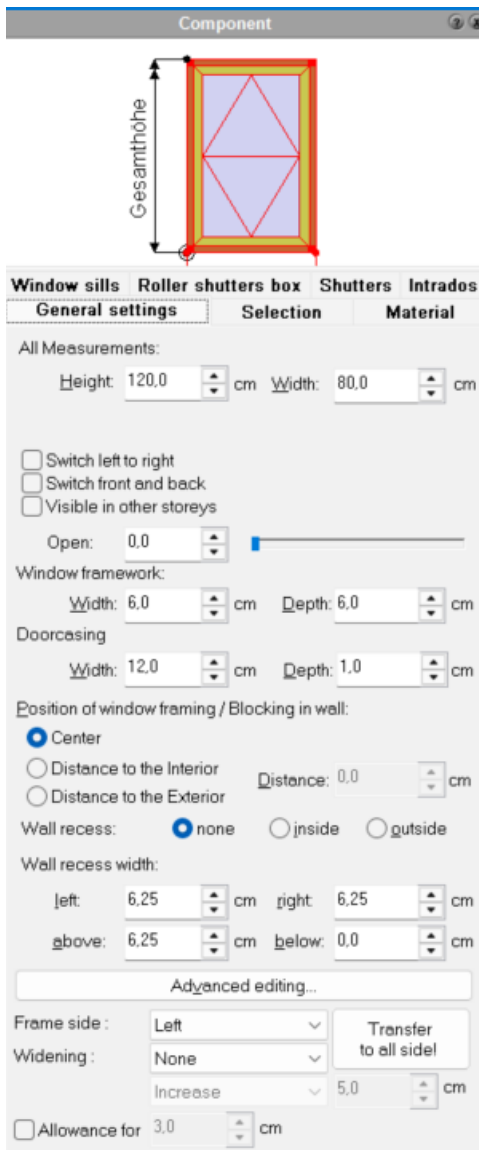

The options available in the tabs:

General settings  
 Selection  
 Materials  
 Window sills  
 Shutter box  
 Shutters  
 reveal

are the same as those in the **Windows** chapter. Further information in the chapter [Window layout](#)<sup>192</sup>.

## 12.13 Foundations

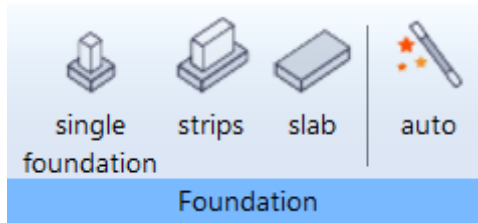

Foundations can be drawn as individual foundations, as strip foundations and as foundation slabs.

Individual foundations can be entered as a foundation (rectangle) or as a polygon

Strip foundations are entered polygonally, similar to the wall input.

Foundation slabs can be entered polygonally or rectangularly

Strip foundations intersect with each other

### 12.13.1 Input bar



OK Top edge ...

Height .....

Offset .....

a foundation slab that skips 10 cm can be constructed with an offset of 10 cm along the outer edge of the wall.

Specify the top edge of the foundation here

The height of the foundation from the top edge downwards

With polygonal input, the offset makes it easier to enter contours. For example,

### 12.13.2 Property dialogs



#### 12.13.2.1 Catalogue

Supports that are used frequently are stored in the catalog. Further information on [catalogs](#)<sup>150</sup> can be found in the [General properties dialogs](#)<sup>134</sup> chapter.

#### 12.13.2.2 Foundations

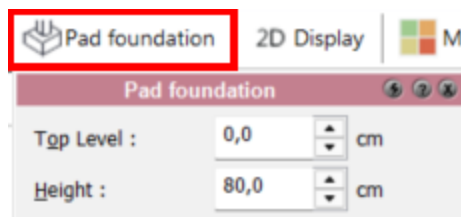

The height and top edge of the foundation can be defined in this dialog.

### 12.13.2.3 Contour /Fill/Hatching

These dialogs are used to define the 2D representation of the support. Further information on the [Contour](#)<sup>[138]</sup>, [Fill](#)<sup>[140]</sup> and [Hatching](#)<sup>[141]</sup> properties can be found in the [General properties dialogs](#)<sup>[134]</sup> chapter.

### 12.13.2.4 Material

In this dialog, you can define the material of the support in 3D mode. Further information can be found under [Surface](#)<sup>[145]</sup> in the **General properties dialogs** chapter.

If required, define different surface materials for the support, base and head:

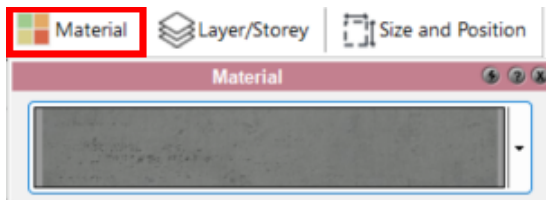

### 12.13.2.5 Properties

Further information on the [properties](#)<sup>[145]</sup> can be found in the [General properties dialogs](#)<sup>[134]</sup> chapter.

### 12.13.2.6 Masses

Further information on the **masses** can be found in the [General properties dialogs](#)<sup>[134]</sup> chapter.

### 12.13.2.7 Position number (PosNr)

Further information on the [position number](#)<sup>[147]</sup> can be found in the [General properties dialogs](#)<sup>[134]</sup> chapter.

### 12.13.2.8 Layer/Floor

The layer and the storey of the column can be changed in this dialog. If you change the storey, the height of the column is also moved to the new storey. For more information, see [Layer/storey](#)<sup>[143]</sup> in the [General properties dialogs](#)<sup>[134]</sup> chapter.

### 12.13.3 Self-funding

In this dialog, you can create a simple foundation for your project. Select foundation slab, single or strip foundations as the type.

With the separate storey option, the foundations are created in a separate storey foundation.

The height is the foundation height, the upper edge of the foundations is entered based on the existing components

Attention!!! The existing foundations are deleted from the project.

#### 12.13.3.1 Size/Position

The **Size/Position** form allows you to specify the size of the support, the rotation and the position in the planning alphanumerically. For more information, see [Size/Position](#)<sup>[143]</sup> in the [General properties dialogs](#)<sup>[134]</sup> chapter.

## 12.14 Stairs

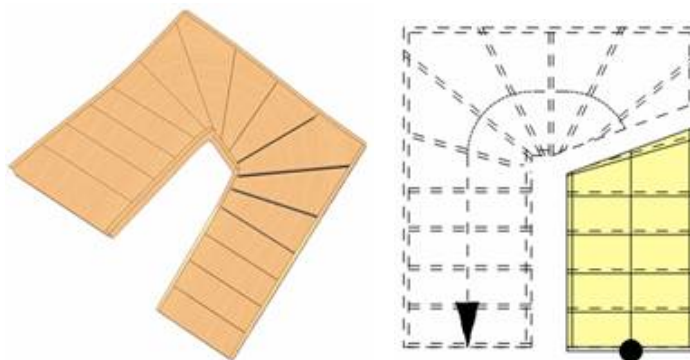

### 12.14.1 General information

The following input types for stairs are available in <%SOFTWARE% >: the straight, single-flight staircase, the L-shaped platform staircase, the L-shaped spiral staircase, the U-shaped platform staircase, the U-shaped spiral staircase, the free platform staircase, the free spiral staircase, the general staircase, the spiral staircase and an extended input of the staircase contour and flight line.



The individual functions are explained below. Each staircase, regardless of the input type, can be designed as a wooden staircase, a solid staircase (also underpinned) or a metal staircase (steps only). As with other components, changes in the properties dialogs are shown immediately after the change in the planning. This makes it easy to visually check the size, position and appearance of the staircase in the model.

### 12.14.2 Draw stairs

When drawing stairs, please note that some stair parameters such as the number of risers, tread or similar can only be determined automatically after the stairs have been placed. The size and course of the staircase are defined during input; only then are the requirements for calculating these parameters fulfilled.

Click on the **Stairs** button  to start the **Draw stairs** function.

- **Straight staircase**

Select straight **stairs** from the **Input type** selection list.

The user is now expected to enter three points to place the staircase. The first two points define the length and direction of the staircase, the third point defines the width.

Once the third point has been entered, the staircase is placed in the planning.

- **L-shaped staircase with landing**

Select the L-shaped **landing staircase** from the **Input type** selection list.

The 3 points on the outer edge of the stairs are now entered.

The width is set in the Stairs/Shape properties dialog.



- **L-shaped spiral staircase**

Select the L-spiral **staircase** from the **Input type** selection list .

The entry is made in the same way as for L-shaped landing stairs.

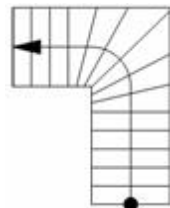

- **U-shaped stairs with landing**

Select the U-shaped **platform staircase** from the **Input type** selection list.

Now enter 3 points on the outer edge of the staircase, starting at the tread. The second flight is always the same length as the first.

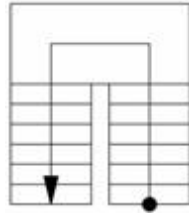

- **U-shaped spiral staircase**

Select the U-shaped spiral *staircase* from the *Input type* selection list.

Starting at the start, 3 points are now entered at the outer edge of the staircase. The second flight is always the same length as the first.

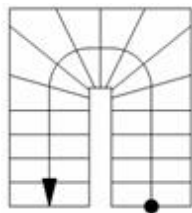

- **General spiral staircase**

Select the general spiral *staircase* from the *input type* selection list.

The entry is made in the same way as for general landing stairs.

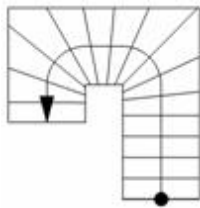

- **General landing stairs**

Select General landing *stairs* from the *Input type* selection list.

A flight of stairs and a landing are created alternately along the edges.

Any number of points can now be entered on the outer edge of the staircase, starting at the start. Four points are required for the example. As shown, an uneven U-shaped staircase can be drawn with this type of input.

The reference point can be changed with *W*.

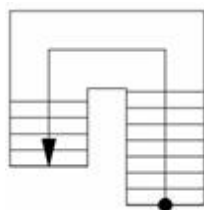

- **General staircase**

Select General *stairs* from the *Input type* selection list.

The contour is entered polygonally, similar to the general platform staircase. Note that the position of the reference axis can be changed with *W* during input. Three segments are drawn

for this example. After placing the staircase, you can select separately for each segment whether it is a landing or not and whether the start or end of the segment is spiral or not.

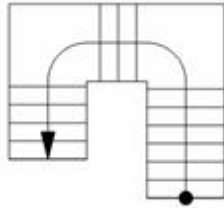

#### Free staircase design

The advantage of this type of input is that even very complicated stairs can be designed. However, the input is more complex than the options described above and requires some practice.

##### Step by step:

1. Start at the beginning of the staircase.
2. First construct the right-hand stair contour (red) by entering the polygon points.
3. Press **[Esc]**.
4. Construct the exit (1 segment, green).
5. Now enter the left stair contour from the exit to the start by entering the polygon points (red).
6. End the input with **[Esc]**.
7. The tread is automatically added and displayed in blue.
8. Now draw the running line (polygonal).
9. End the input with **[Esc]**.

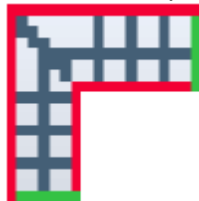

#### Spiral staircase

Select the spiral staircase from the *Input type* selection list.

##### Step by step:

1. define the center of the spiral staircase by clicking the left mouse button
2. move the mouse and use the second point to define the radius and also the starting point of the staircase.
3. the third input point defines the direction of the staircase (clockwise or anticlockwise)
4. the fourth point defines the preliminary end point of the staircase, where by a maximum angle of 359 degrees is initially possible. A larger angle for the turn is possible by later editing in the [Stairs properties dialog](#)<sup>364</sup>.

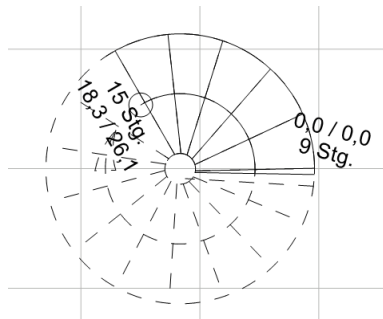

### 12.14.3 The overview bar

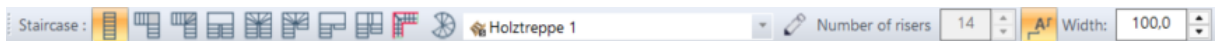

In the overview bar, the stair type, the number of risers, the entry width and the exit width of the stairs are set.

The number of risers can be set automatically using the  button.

### 12.14.4 Property dialogs

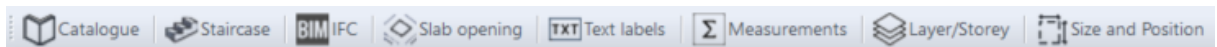

#### 12.14.4.1 Catalogue

Stairs that are frequently used are stored in the catalog. The properties are saved there, not the stair shape.

Further information on [catalogs](#)<sup>[150]</sup> can be found in the [General properties dialogs](#)<sup>[134]</sup> chapter.

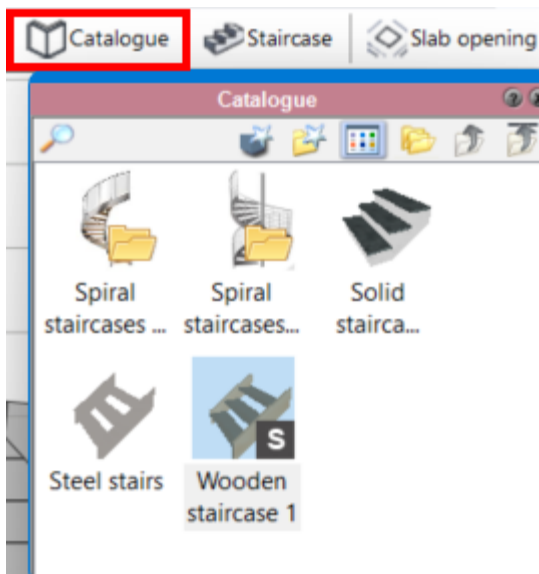

#### 12.14.4.2 Staircase/Shape

##### 12.14.4.2.1 Dimensions

Depending on the type of staircase used, the dimensions are offered in dialog. For a U-shaped platform staircase, for example, the **total length**, the **total width**, the **entry** and **exit width** and the **platform width** are available. For stairs with a variable number of flights (all general types), the individual segment dimensions are defined in the lower part of the dialog.



To change the width of a segment, deactivate the option *like end width of previous segment* or *like start width*.

12.14.4.2.2 Design

#### Classical wood staircases

Solid staircases with side panel

Solid staircases, underwall

Only steps (float)

Choose from four options:

**1. classic wooden staircase**

creates a wooden staircase with stringers, treads and risers



**2. solid staircase side panel**

creates a solid tread, treads and risers

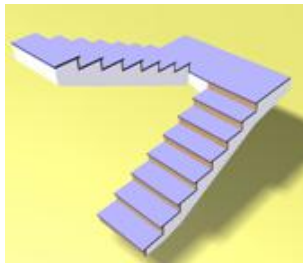

**3. solid staircase, underwall**

as 2., but no tread plate is drawn. The staircase is shown closed along the staircase polygon down to the lower level.

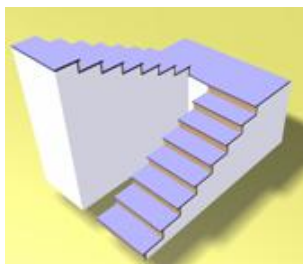

**4. Only steps**

Only treads and risers are shown.

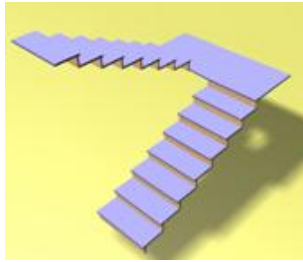

#### 12.14.4.2.3 Editing stairs

The following editing options are available on the **Detail tab**:

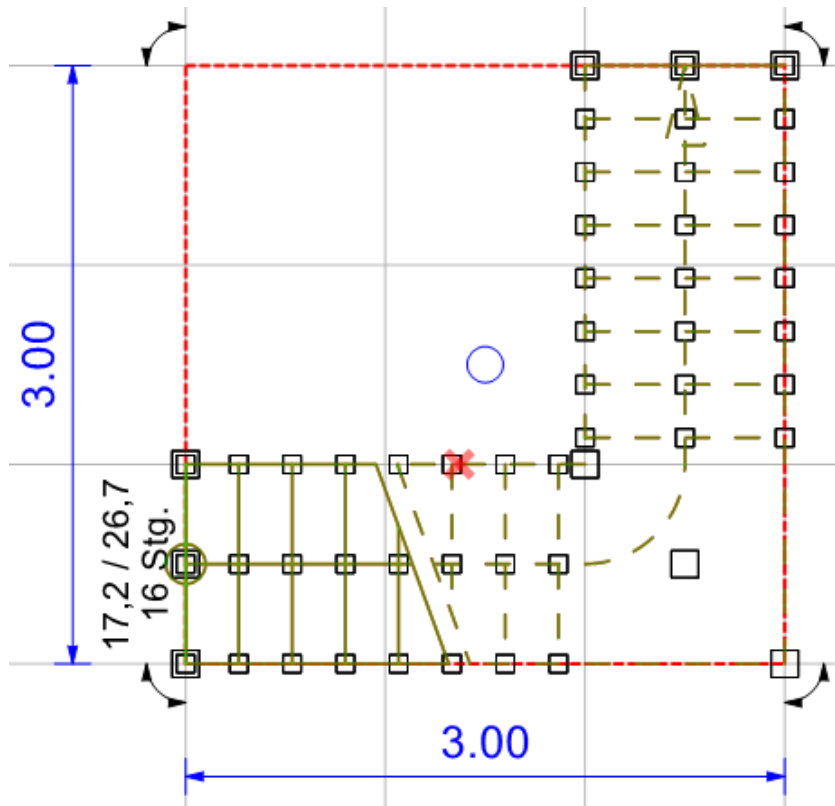
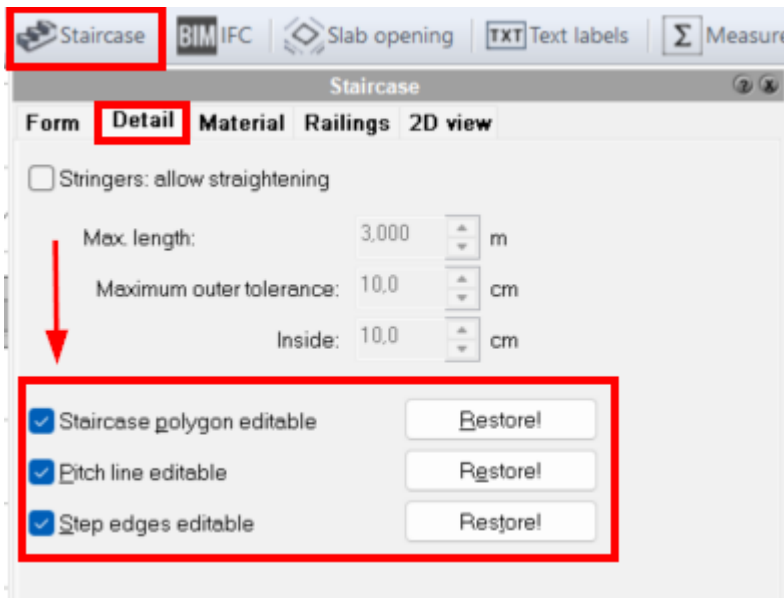

Staircase polygon editable

### Edit staircase polygon

Select the **Staircase polygon editable** option to edit the position of the polygon points of the stair contour. A marking is shown at the corner points.

The staircase must not be selected for subsequent editing.

Move the mouse cursor over the marking and press the right mouse button. In the context menu, select **Staircase polygon point X** and the **Move** sub menu. The polygon point can now be moved. Use the snap functions to define the exact position.

After editing, we recommend deactivating the option **Staircase polygon editable** again.

The **Reset** button ! undoes all changes and restores the original polygon.



#### Edit Pitch line

The steps are created along the tread line at the distance of the tread. The position of the tread line therefore determines the position at which the tread width is measured.

Select the **Editable** tread line option to edit the position and shape of the tread line. A marking is shown at the end points and at the front edge of each step.

The staircase must not be selected for subsequent editing.

Move the mouse cursor over the marking of an end point and press the right mouse button. In the context menu, select **Pitch line segment point X** and the **Move** sub menu. The polygon point can now be moved.

Move the mouse cursor over the marking of a step leading edge and press the right mouse button. In the context menu, select **Line point of step X** and the **Move** sub menu. The polygon point can now be moved, but is always on the running line between the running line end points.

Use the snap functions to define the exact position.

The **Reset** button ! undoes all changes and restores the original running line.



#### Edit step edges

Select the **Editable** step edges option to adjust the angle of step leading edges. A marking is shown at the end points of the leading edge.

The staircase must not be selected for subsequent editing.

Move the mouse pointer over this marking and press the right mouse button. In the context menu, select **Right/left step edge point of step X** and the **Move** sub menu. The polygon point can now be moved.

The leading edge of the step is rotated around the running line point.

**Note:** For the above edits, the **Move unselected elements with the mouse** option must be activated in the **general input options**.

## 12.14.4.2.3.1 Calculation

Shape tab :

The screenshot shows the 'Staircase' software interface. The 'Form' tab is selected and highlighted with a red box. The 'Staircase' tab is also highlighted with a red box. The interface displays various parameters for a staircase, including Type (Classical wood staircases), Entire width (-100,0 cm), Entire length (181,75 cm), Number of risers (12), Tread depth (16,5 cm), Step 2r+t (62,4 cm), Riser height (22,9 cm), Bottom Level (0,0 cm), Top Level (275,0 cm), Stringers width (4,0 cm), Stringers addition or height of underflight (0,0 cm), Step depth (3,0 cm), Nosing (2,0 cm), Stringer overhang (3,0 cm), and Depth (3,0 cm). There are also checkboxes for 'Fix beginning', 'Fix end', 'Automatic', 'at Finished Floor Level', and 'to Finished Floor Level above'.

The parameters of the staircase are normally calculated automatically.

**Height:** The basis for the calculation is the stair height, which is calculated from the difference between the level at the bottom and the level at the top. The levels are suggested with the upper edge of the floor; for different settings, select the corresponding radio button and change the value.

**Height of rise - tread:** The *automatic* option determines whether the stair parameters for tread, rise etc. are calculated automatically or entered by the user. If the option is not active, the values can be changed. The target value and the actual value are shown for tread width, step size and rise height (target values cannot always be achieved exactly, but the program attempts to approximate these values, taking into account the other inputs).

**Entry - exit:** When entering the staircase, the staircase polygon and therefore the entry and exit points are defined. These points can be subsequently relocated by removing the **Fixed start** and **Fixed end** options. The entry and exit points are then moved by changing the parameters.

**Total angle:** Here, for example, a **spiral staircase** can be given a turn of more than 359 degrees.

Staircase

Form: Detail Material: Railing 2D view

Type: Classical wood staircases

Entire width: 78.365

Start width: 39.37

Revolution angle: 179.972 Static

Starting angle: 105.0 Static

Number of risers: 12 Automatic

Tread depth (theoretical): 5.6 is: 5.6 "

Step 2r+t (theoretical): 23.6 is: 23.6 "

Riser height (theoretical): 9.0 is: 9.0 "

Bottom Level: 0.0 at Finished Floor Level

Top Level: 108.3 to Finished Floor Level above

Stringers width : 1.575

Flight structure thickness: 5.9

Step depth : 1.181

Nosing : 0.787

Stringer overhang up/down: 1.181 0.0

Risers on/off Depth: 1.181

with landing  round landing

Landing angle: 90.0 Static



**Railing** tab: Select the *type of* railing from the drop-down list.

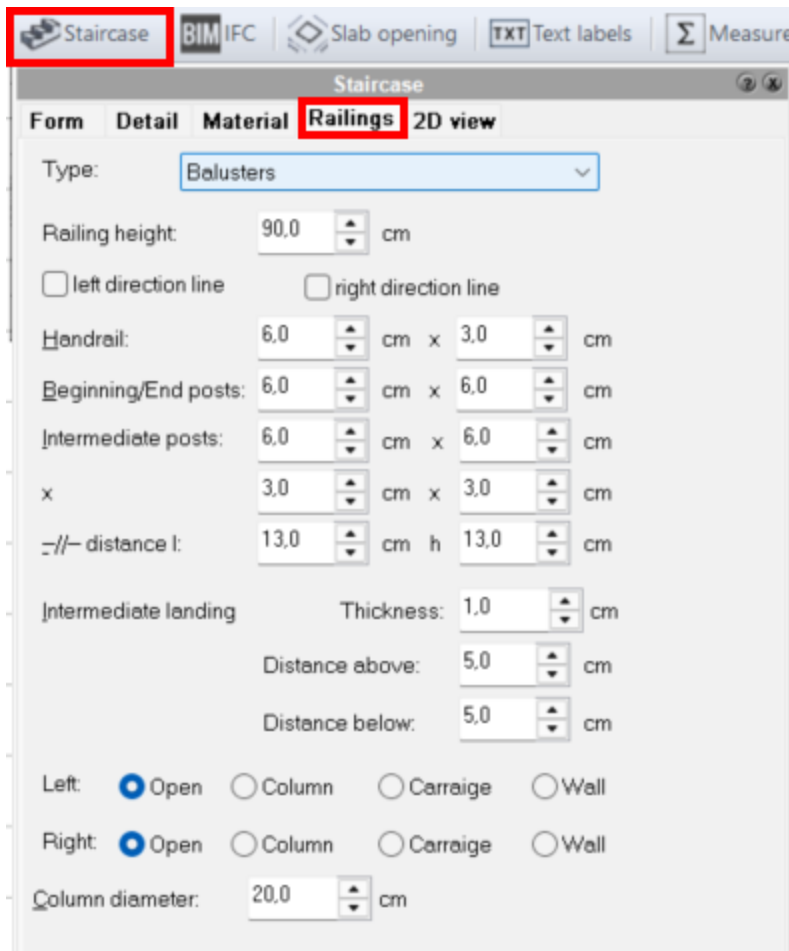

The following railing types are available in the drop-down field under **Construction type**:

- Balusters
- Middle rails
- Platforms/Slabs/Panels
- Only handrail
- Only handrail with posts
- Landing with balusters
- Middle rails with balusters

**Balusters:**



Middle rails):

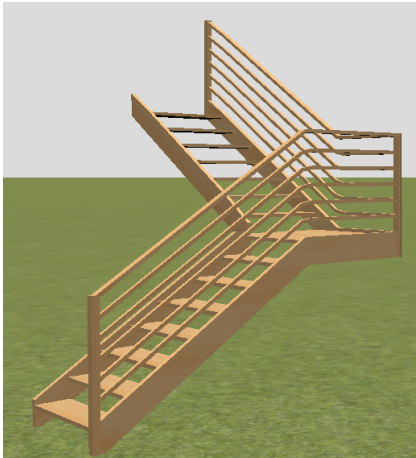

Platforms/Slabs/Panels:

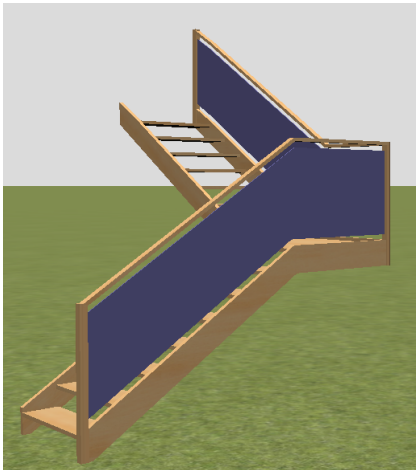

Only Handrail:

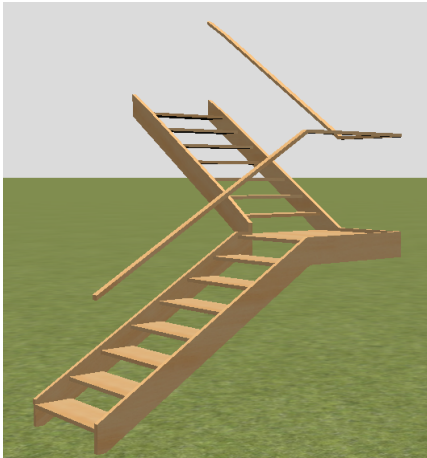

**Only Handrail with posts:**

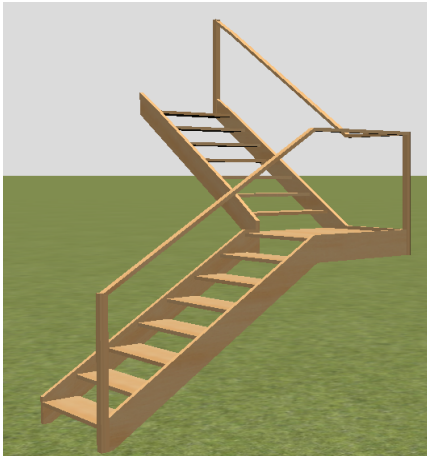

**Landing with balusters:**



Middle rails with balusters:

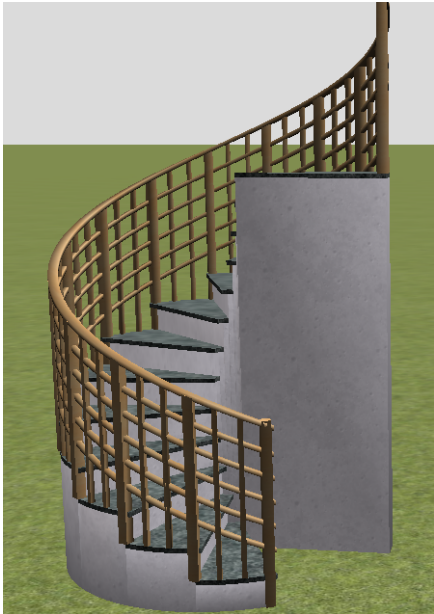

Material tab:

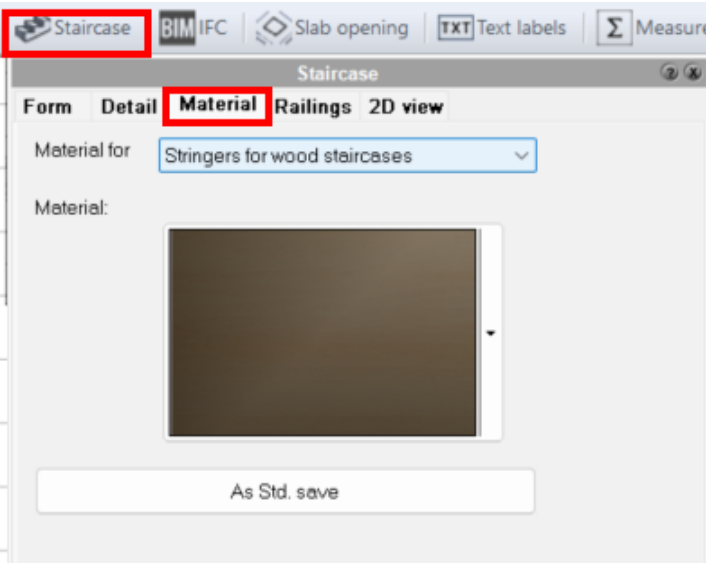

In the **Material for**: drop-down field, you can select the components of the stairs for which a material type is to be defined:

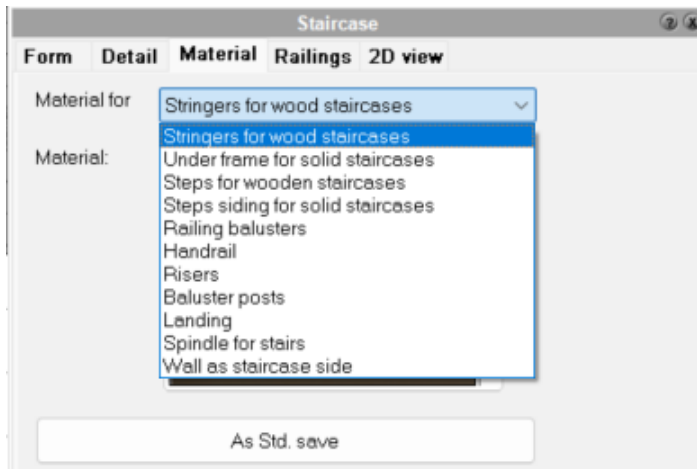

Double-click on the field next to the **Material:** entry to open the material explorer:

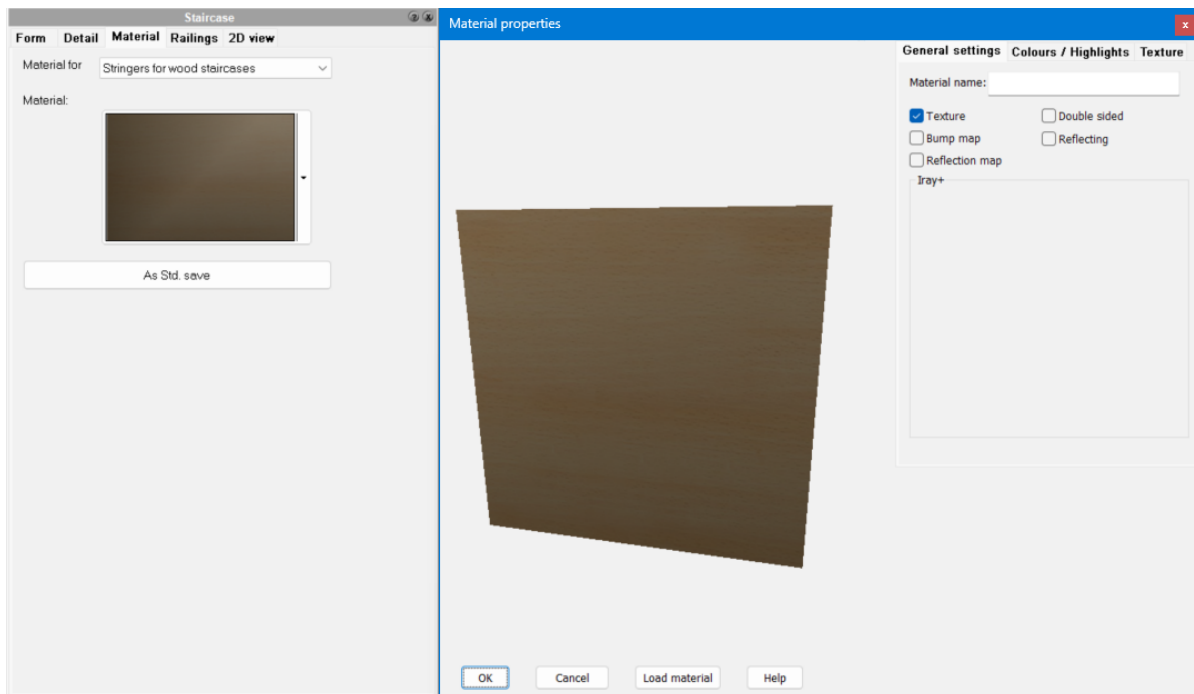

#### 12.14.4.2.4 2D representation

The 2D view allows you to adapt the staircase in the floor plan to the preferred plan graphic in your office, depending on the current level of detail. The first checkbox of the dialog should be deactivated to see the 2D representation of the staircase. Alternatively, the edges of the 3D representation would be shown.

This setting can be activated if you use the **deposited 2D view** function. With this function, all materials of the 3D model are shown in the floor plan; the edges of the staircase display provide better results, especially with a sectioned display. If this function is active, all other settings in this dialog are irrelevant.

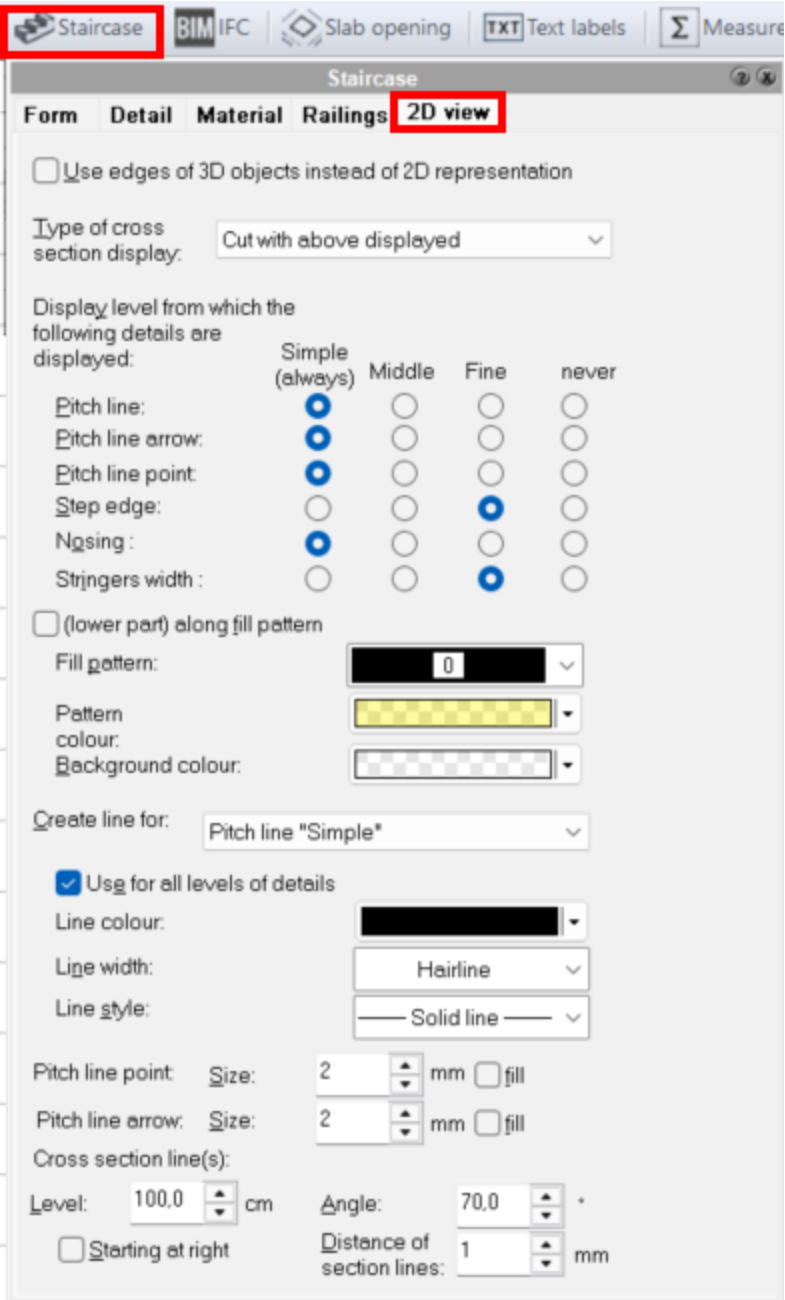

The **Type of sectional view** selection list

- Do not cut
- Cut with above displayed
- Cut without above displayed

There are three options for displaying the stairs in the floor plan:

- **Do not cut** - The entire course of the staircase is displayed uncut. The parameters for the section line such as level, angle etc. are not taken into account. If the staircase is displayed filled, the entire staircase outline is filled.

- **Cut with above displayed** - The staircase is cut at the point of the tread line at the height of the level value. The cut line angle and the distance between the cut lines can be set. The upper part of the staircase is shown as a dashed line.
- **Cut without above displayed** - The staircase is displayed cut as described under point 2, but the part above the cut line is hidden.

#### Which details of the staircase are shown?

In the matrix, you can set the level of detail from which each element of the 2D **staircase** display is visible. For example, if you select the *Medium* setting for the line of the undercut, this line will be shown from the Medium level of detail (also in the *Fine* level of detail).

The **Line properties for selection list** allows you to set the [color, thickness and style](#)<sup>[138]</sup> parameters of the 2D display [lines](#)<sup>[138]</sup> separately according to the individual elements and the level of detail. The **Use for all levels of detail** option transfers the current setting to all levels of detail, but only for the selected element.

The height of the section level can be entered, the angle and distance of the section lines are variable. The height refers to the height of the active storey. A staircase on the ground floor with a cutting height of one meter is also cut at one meter in the *active upper floor* display. However, this cutting height is above the staircase, which means that the staircase is not correctly displayed as cut.

The **Start right** checkbox reflects the cutting direction.

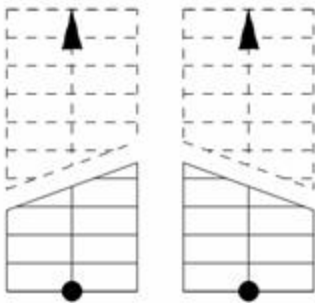

#### 12.14.4.3 Ceiling opening

If you have placed a staircase, Plan7Architect automatically generates a recess in the ceiling of the current storey above the staircase.

If the automatic recess does not fit, any ceiling recess can be drawn using the **Recess** button  in the construction bar.

Automatically created recesses are always directly linked to the staircase and cannot be edited further. There are three options to choose from:

- **Entire staircase outline:** The entire outline is displayed as a recess. This variant is mainly used for straight and L-shaped stairs. U-shaped staircases are better drawn with a conventional ceiling recess, as the automatic ceiling opening is also drawn in the staircase eye.
- **For minimal height:** Determines the ceiling recess that takes into account the minimum clearance when walking on this staircase. If you change the value for the minimum clearance in this dialog box, the recess contour is adjusted.
- **None:** No recess is drawn. This option is used if the contour of the ceiling recess differs from the stair outline. Complete the freely constructed recess with the **Ceiling recess** command in the construction bar.

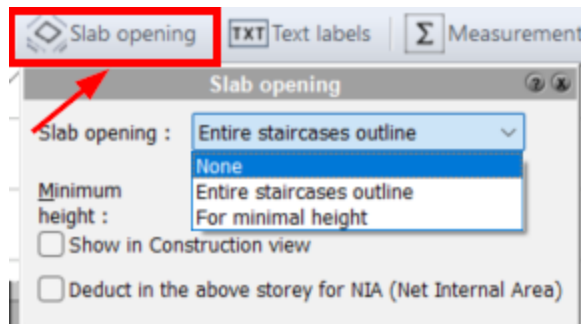

#### 12.14.4.4 Labeling

Stairs can be labeled automatically in Plan7Architect. The number of inclines and, in a second line, the incline and the tread are labeled.

**Display:** For both values, you can specify in the selection list whether they are to be displayed. The **default** setting is based on the settings in the **ProjectLabeling** menu - **Stairs** tab. The advantage for the user of leaving the values at **default** is the ability to select the visibility of all labels in the project at the same time.

**Automatic positioning:** The staircase labeling is automatically placed at the starting point of the staircase. You can move each line individually with the mouse; the checkbox is then deactivated. If you activate the property again, the corresponding text is placed in the default position.

**Font:** Use this property to specify the font for the staircase labeling. If **Use default font** is selected, the default font from the **ProjectLabeling** menu - **General tab** is used. If you deactivate this property, an individual font can be set.

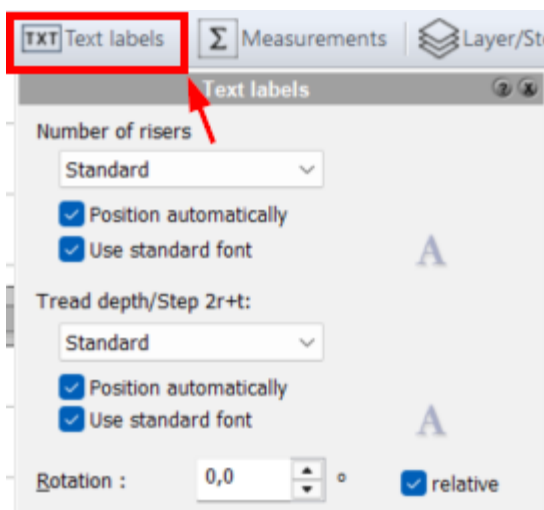

#### 12.14.4.5 Properties

Further information on the [properties](#)<sup>[145]</sup> can be found in the [General properties dialogs](#)<sup>[134]</sup> chapter.

#### 12.14.4.6 Position number (PosNr)

Further information on the [position number](#)<sup>[147]</sup> can be found in the [General properties dialogs](#)<sup>[134]</sup> chapter.

#### 12.14.4.7 Layer/Floor

The layer and floor of the staircase can be changed in this dialog. Stairs are stored on the **Stairs** layer. However, subsequent changes are possible. If you change the storey, the staircase is moved to the new storey and the heights of the staircase are adjusted to the new storey heights. For more information, see [layer/floor](#)<sup>[143]</sup> in the chapter [General properties dialogs](#)<sup>[134]</sup>.

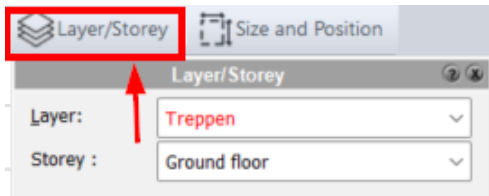

#### 12.14.4.8 Size/Position

The **Size/Position** form allows you to define the rotation and the position in the planning alphanumerically. For more information, see [Size/Position](#)<sup>[143]</sup> in the [General properties dialogs](#)<sup>[134]</sup> chapter.

This form has no meaning for **stairs**!

#### 12.14.5 Influence of or on other components

##### Rooms

Stairs have an influence on the area and volume calculation of rooms. Please note the settings under *Options|Room info*.

##### Walls

The height of walls can be intersected under stairs. Activate the corresponding option in the properties dialog *Construction|Levels of wall*.

##### Railing

A simple banister can be created along each staircase. (see properties dialog **Stairs|Railings**).

##### Ceiling openings

A ceiling opening is created with each staircase if this option has not been deactivated.

##### Floors

The stair height and also the entry and exit level can be determined automatically from the heights of the current storey. If the storey height changes, the staircase is adjusted accordingly.

## 12.15 Railing

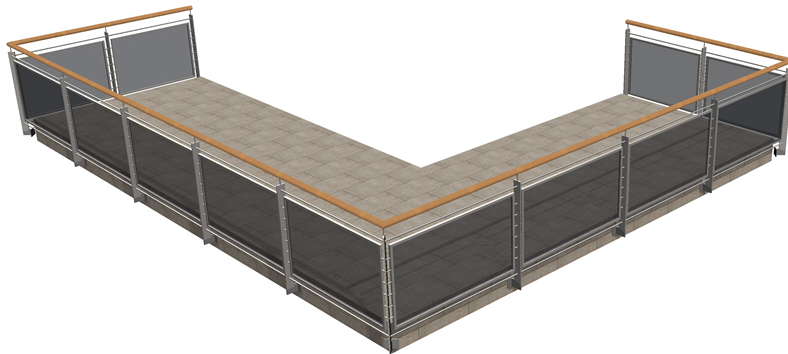

### 12.15.1 Drawing railings

Click on the button **Gelaender**  in **Construction** mode.

#### Catalog for component templates

The easiest way to define all the parameters of the new railing is to select a corresponding component template from the catalog. To do this, open the catalog and click on the relevant template. All values of the template are adopted and the railing can be placed in the drawing.

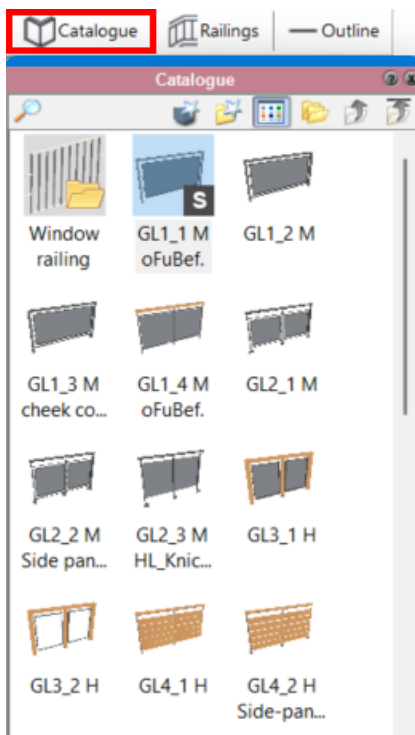



Of course, all parameters can also be changed after assigning a template. Further information can be found in the [General properties dialogs](#) <sup>1341</sup> chapter.



### 12.15.1.1 Input types

- **Railing (open/closed polygon)** 

Required input: n points  
 The railing is entered using any number of corner points. End the input with **[Esc]**. To cancel the action during input, select **Cancel function** from the context menu.

 Possible input options: Offset - the railing is constructed parallel to the input points with offset.
- **Railing (rectangle)** 

Required input: 2 points  
 The railing is entered via two diagonally opposite corner points.

 Possible input options: Offset - the railing is constructed parallel to the input points with offset.
- **Railing (rotated rectangle)** 

Required input: 3 points  
 First define one side of the rectangle with two points. The height of the rectangle is defined with the third point.

 Possible input options: Offset - the railing is constructed parallel to the input points with offset.

### 12.15.2 Property dialogs

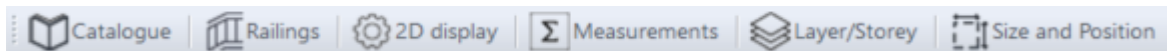

#### 12.15.2.1 Catalogue

Railings that are used frequently are stored in the catalog. Further information on [catalogs](#)<sup>[150]</sup> can be found in the [General properties dialogs](#)<sup>[134]</sup> chapter.

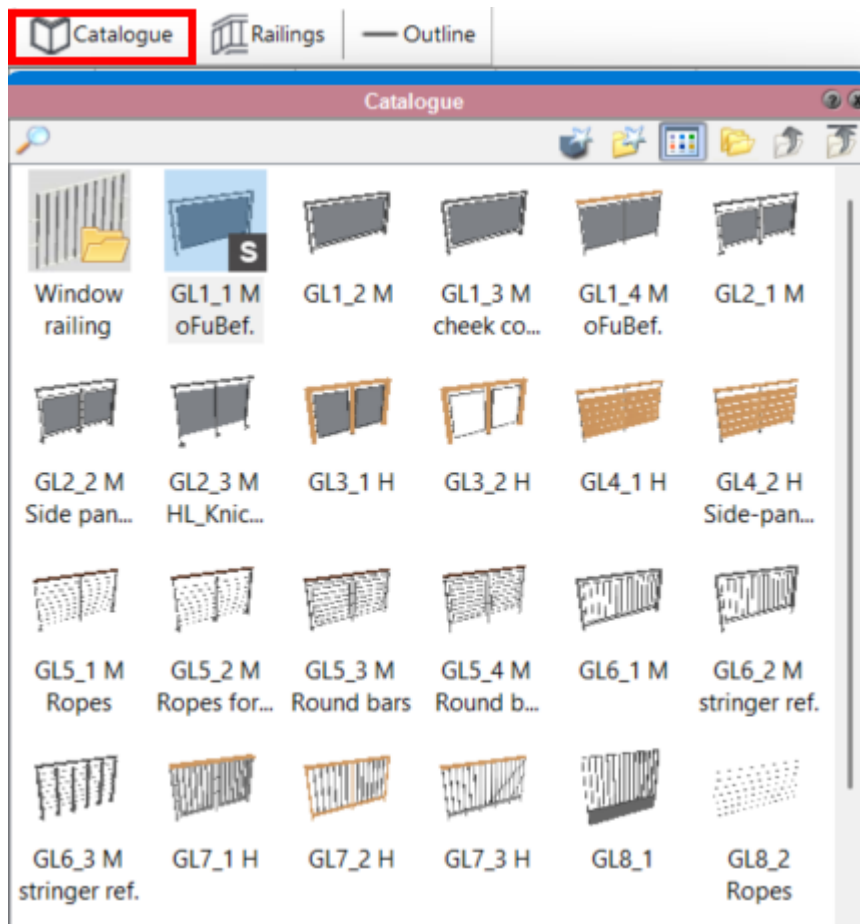

## 12.15.2.2 Railing

### 12.15.2.2.1 General information

Fill	Material	2D display
General	Posts	Handrail

General tab:

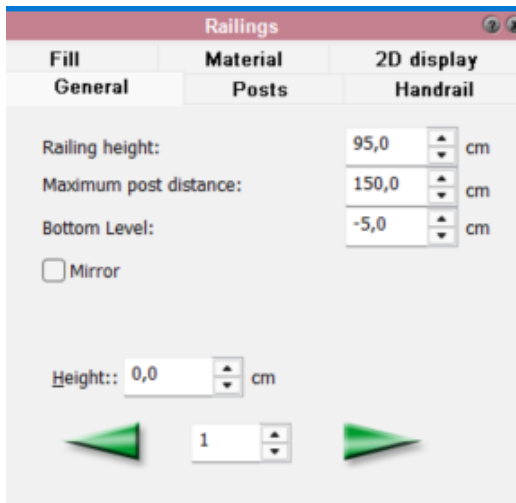

### Options tab:

Set the height of the railing, the post spacing and the distance of the railing to the ground here.

It is also possible to define **individual height levels** at each **polygon point** (select with the **green arrow keys**):

(In this example, the third polygon point of the railing has been assigned a level raised by 70 cm)

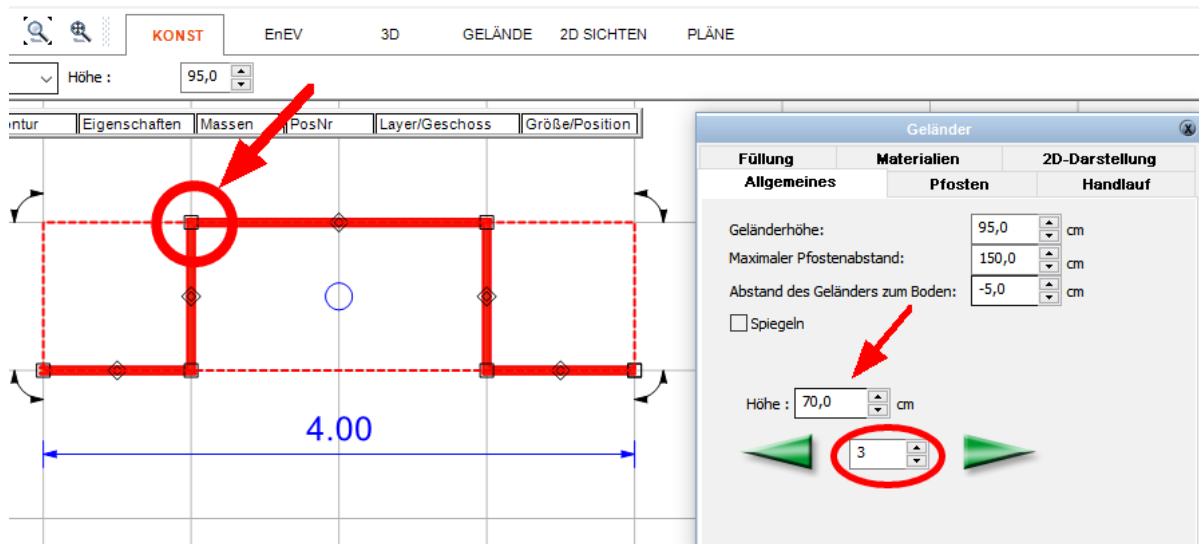

The result in the 3D view:

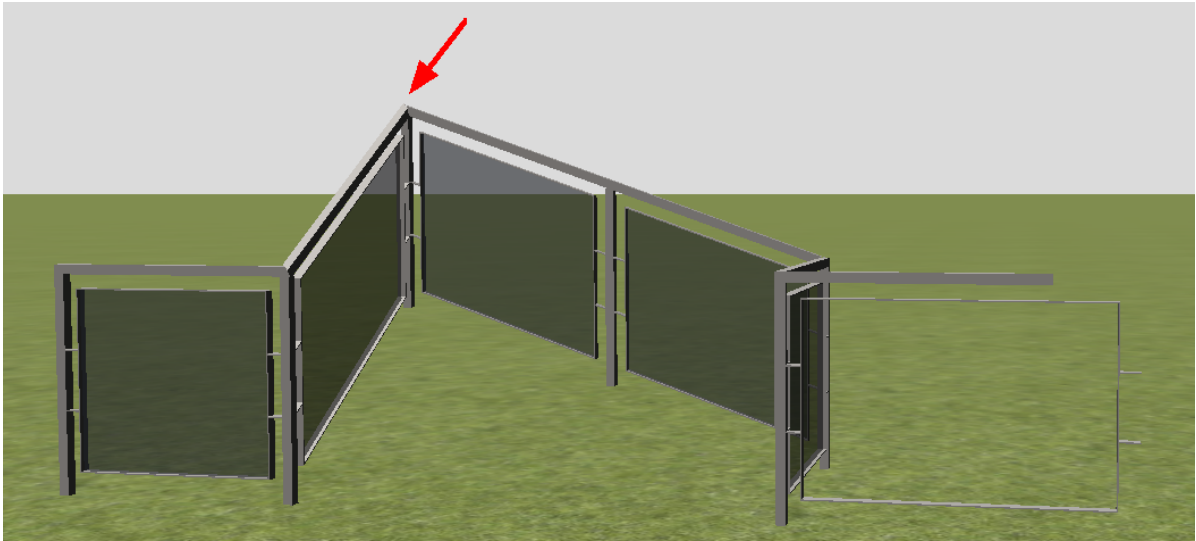

## 12.15.2.2.2 Post

**Post tab:**

**Create posts:** Display railings with/without posts.

**Use 3D object:** Load a 3D object from the template catalog or from a file.

Create **base mounts:** Display base mounts.

Create **handrail mount** : Display a handrail mount.

Specify here which **mount** is to be used.

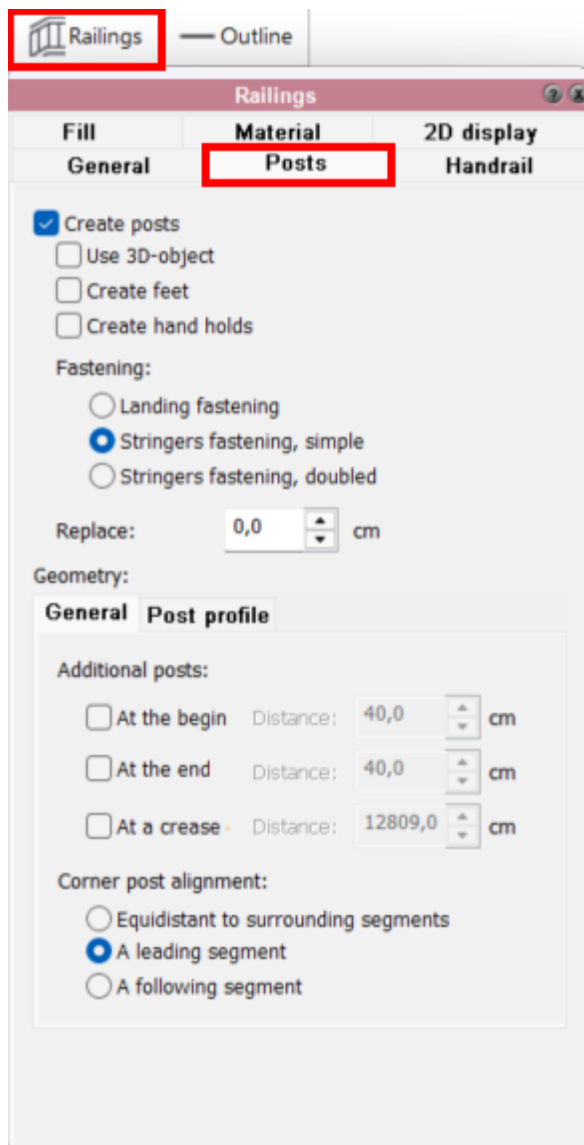

Options-General:

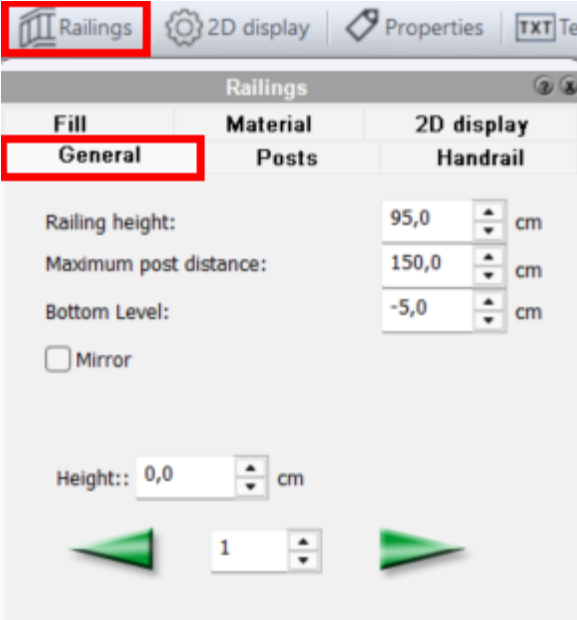

Post profile options:

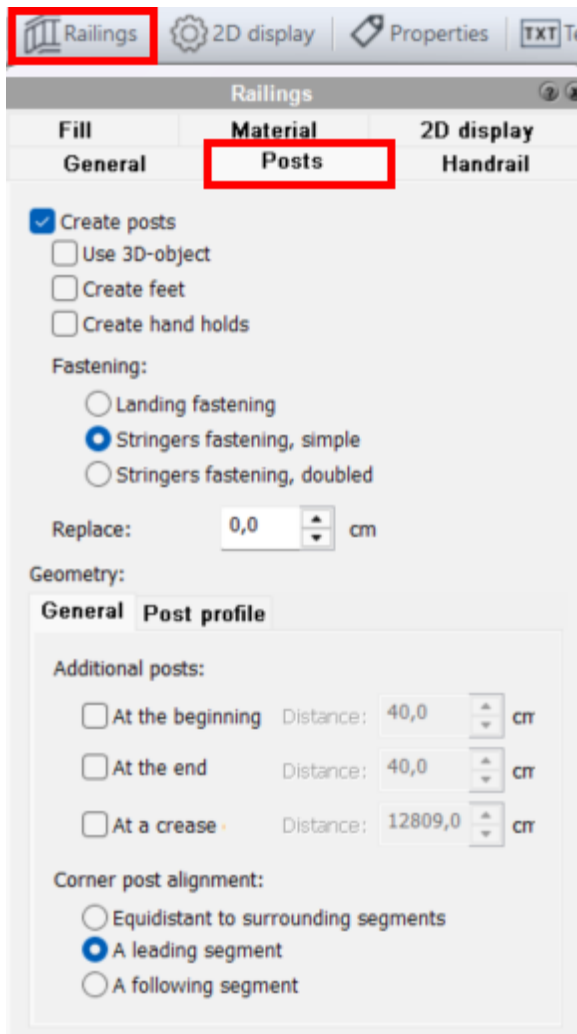

## 12.15.2.2.3 Handrail

**Handrail tab:**

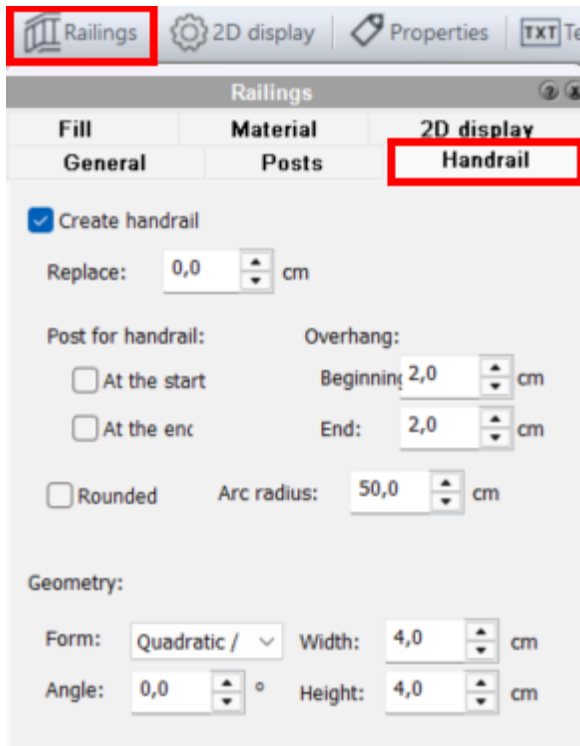

Here you can create a **handrail** for the railing.

The following **options** are available:

Create handrail

Offset: cm

Handrail replaces post

Overhang

at start/beginning cm

at end/end cm

Rounded/bending radius cm

Geometry:

Selection of shape      Width cm

Angle degrees          Height cm

## 12.15.2.2.4 Filling

**Fill tab:**

Create a **fill** for the railing here:

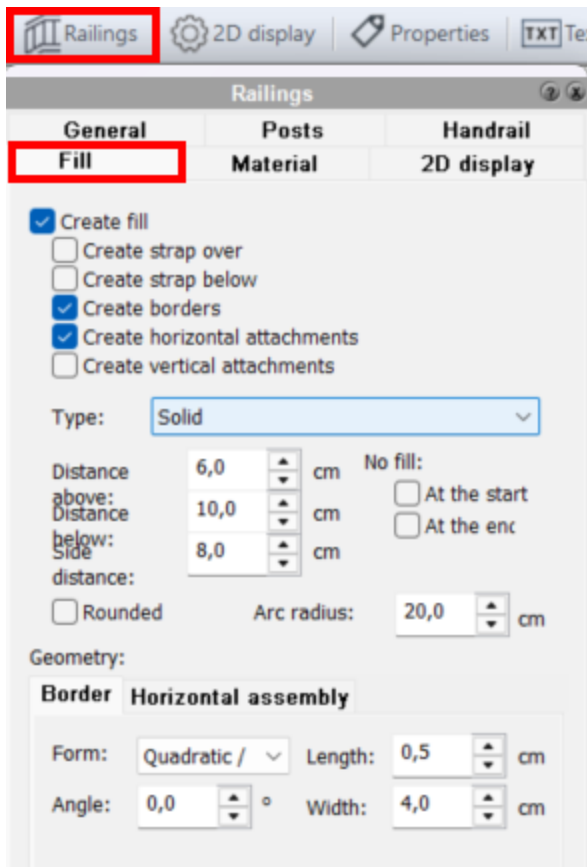

Options **Border**:

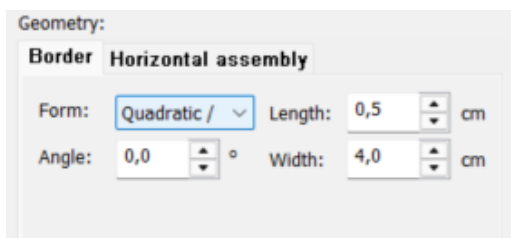

Options Horizontal assembly:

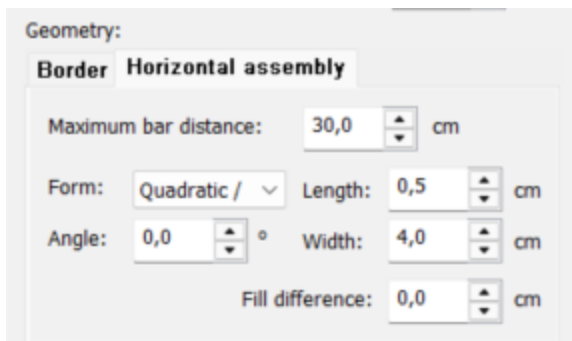

## 12.15.2.2.5 Materials

**Materials tab :**

In this dialog, you can define the railing [materials](#)<sup>[436]</sup> in 3D mode.

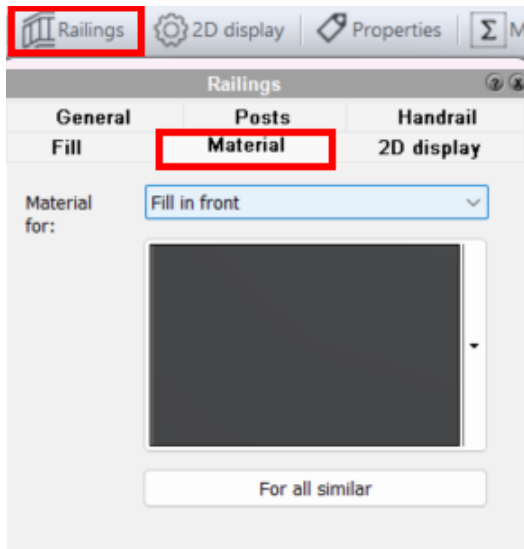

## 12.15.2.2.6 2D representation

**2D representation tab :**

These dialogs are used to define the 2D representation of the railing. Further information on the properties [Contour](#)<sup>[138]</sup> and [Fill](#)<sup>[140]</sup> can be found in the chapter [General properties dialogs](#)<sup>[134]</sup>

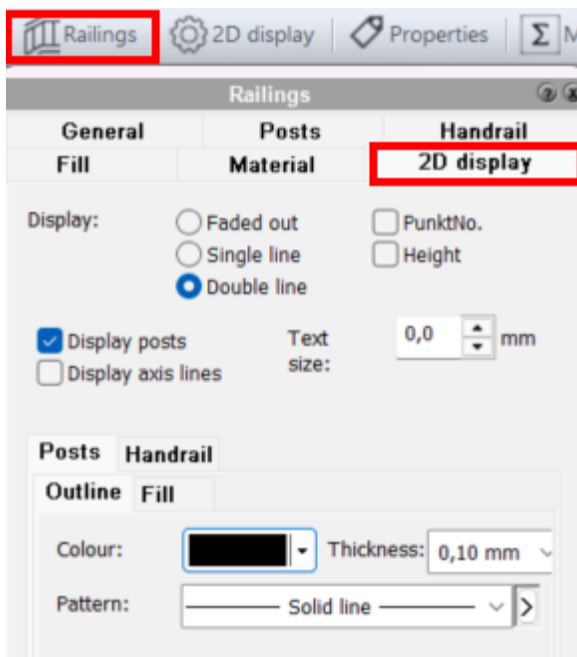

## 12.15.2.3 Contour

Further information on [contour](#)<sup>[138]</sup> can be found in the [General properties dialogs](#)<sup>[134]</sup> chapter.

### 12.15.2.4 Properties

Further information on the [properties](#)<sup>[145]</sup> can be found in the [General properties dialogs](#)<sup>[134]</sup> chapter.

### 12.15.2.5 Masses

Further information on the **masses** can be found in the [General properties dialogs](#)<sup>[134]</sup> chapter.

### 12.15.2.6 Layer/Floor

In this dialog, the layer and the storey of the railing can be changed. If you change the storey, the railing is not also moved in height to the new storey. For more information, see [Layer/storey](#)<sup>[143]</sup> in the [General properties dialogs](#)<sup>[134]</sup> chapter.

### 12.15.2.7 Size/Position

The **Size/Position** form allows you to specify the size of the railing, the rotation and the position in the planning alphanumerically. For more information, see [Size/Position](#)<sup>[143]</sup> in the [General properties dialogs](#)<sup>[134]</sup> chapter.

### 12.15.2.8 Position number (PosNr)

Further information on the [position number](#)<sup>[147]</sup> can be found in the [General properties dialogs](#)<sup>[134]</sup> chapter.

## 12.16 Zones

Similar to the building, a zone is used in Plan7Architect for the hierarchical organization of your project, for example to divide it into apartments, building sections or similar. Unlike buildings, zones have no direct effect on the modeling, but only on the output of area calculations and masses. Zones are assigned to rooms. This is done in the Construction properties dialog.

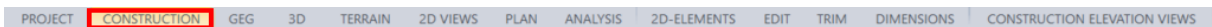

### 12.16.1 Create zone

Create a new zone in the menu **Construction|Project structure|** and enter the name.

### 12.16.2 Rename zone

Use the menu command **Construction|Project structure|** to edit the name of a zone:

### 12.16.3 Delete zone

A zone can be deleted using the **Construction|Project structure|** command. If there are several zones, a dialog for selecting the zone to be deleted appears first.

## 12.16.4 Assign zone

Use the command **Construction|Project structure**

## 12.17 Rooms

### 12.17.1 General information

Rooms are created automatically when drawing walls or virtual walls as soon as the contour of these components results in a closed polygon. If this contour is opened again at any point, the room also disappears again.

You can also create rooms manually at any time using .

If a new room is created, it is indicated in the floor plan by the room stamp of the room. The room name is suggested as **Room 1**, for example. The default values for a new room are defined by the default component. In addition to the room stamp, the room is represented in the floor plan by a polygon. The contour, filling and hatching can be displayed for the floor plan.

The corner points and edges of the room polygon cannot be edited further, e.g. moving a corner point. The room polygon changes automatically as soon as you move the boundary walls or virtual walls. To complete the building model for sections, views and perspectives, the following surfaces are created for each room in addition to the 2D representation described above.

- **Floor surface** - a 3D surface at the height of the finished floor of the room. The floor surface is shown in 3D with the floor texture.
- **Ceiling surface** - a 3D surface at the height of the room's ceiling cladding. The ceiling cladding is shown in 3D with the ceiling texture.
- **Internal roof cladding** - if the room is bounded by a roof, polygons for the internal roof cladding are created at the room/roof interfaces. These polygons are shown with the interior roof cladding texture.

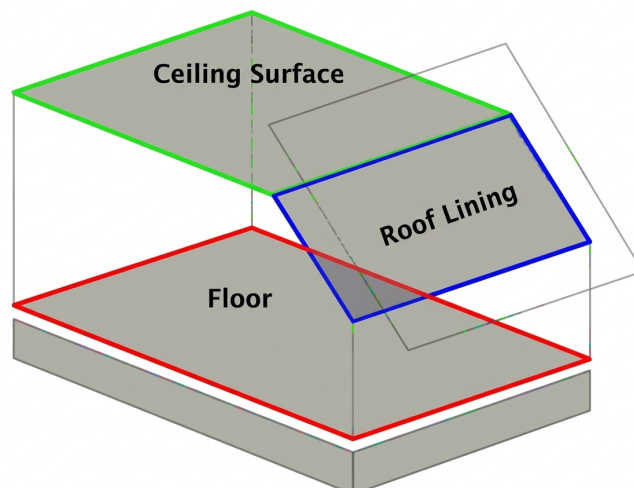

### 12.17.2 Property dialogs

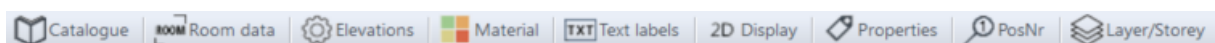

Select a room. The following properties dialogs are displayed:

For more information on the properties *Masses*, *PosNr*<sup>[263]</sup> and *Properties and Layer/floor*<sup>[143]</sup>, please refer to the chapter [General properties dialogs](#)<sup>[134]</sup>.

### 12.17.2.1 Catalogue

The component templates for rooms are listed in the catalog. Further information on [catalogs](#)<sup>[150]</sup> can be found in the [General properties dialogs](#)<sup>[134]</sup> chapter.

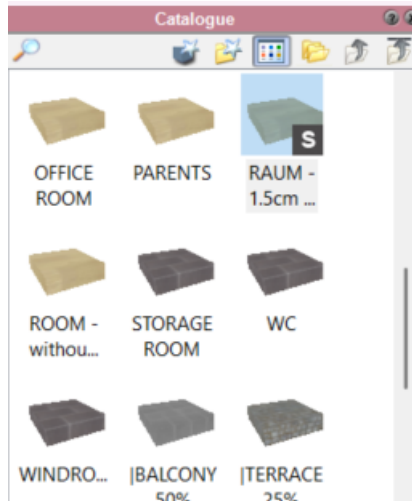

**Direct assignment** of a room from the catalog:

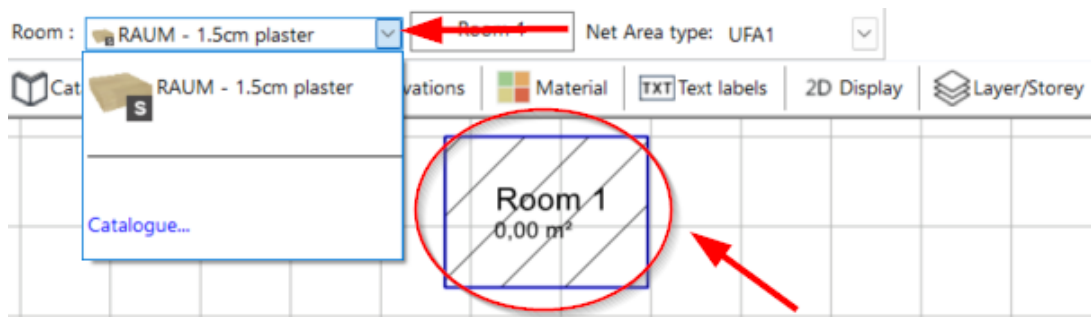

### 12.17.2.2 Room data

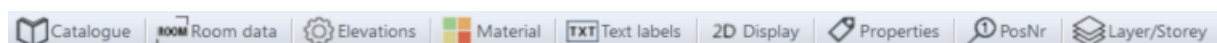

<b>Name</b>	the space allocation
<b>description</b>	a free text field
<b>Floor covering</b>	Text field for the floor covering
<b>Room number</b>	Text field for a room book number
<b>Apartment</b>	Assign the room to an apartment/zone
<b>List in the room info</b>	The room is taken into account in evaluations
<b>Treat as "outside"</b>	the room can be defined as "outside" (e.g. for GEG evaluations)
<b>Usable space type</b>	Assignment of usable space type according to DIN
<b>Enclosure</b>	Type of enclosure for the calculation of living space
<b>Utilization</b>	the living space is calculated at 100%, 50%, 25% or not

**Plaster thickness** Parameters for calculating living space according to DIN

**NEW:** Treat room as **"outside"**: Very helpful setting, e.g. for GEG evaluations: This allows an unheated room, e.g. an attached garage, boiler room/storage room etc., to be marked for the building physics evaluation.

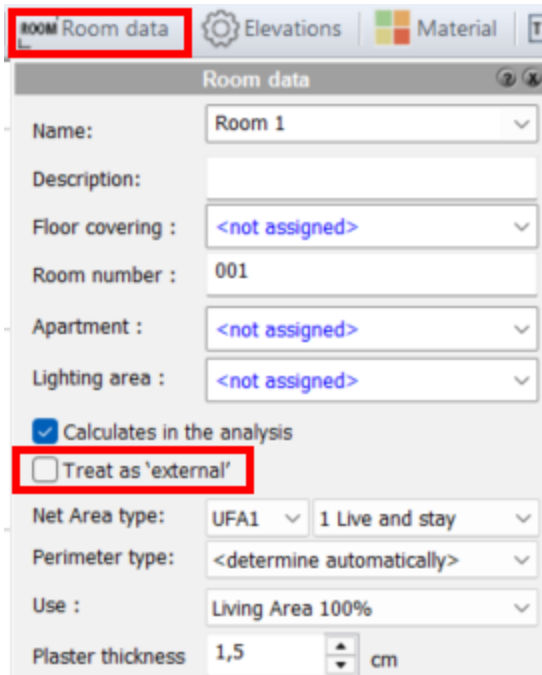

The screenshot shows the 'Room data' dialog box with the following fields and settings:

- Room data** (tab, highlighted with a red box)
- Name: Room 1
- Description: (empty)
- Floor covering: <not assigned>
- Room number: 001
- Apartment: <not assigned>
- Lighting area: <not assigned>
- Calculates in the analysis
- Treat as 'external' (highlighted with a red box)
- Net Area type: UFA1 | 1 Live and stay
- Perimeter type: <determine automatically>
- Use: Living Area 100%
- Plaster thickness: 1,5 cm

### 12.17.2.3 Labeling

#### Room labeling:

Here you can select whether the room labeling is visible or not. There are three options to choose from:

- **Standard:** adopts the setting for the visibility of the room label from the general settings in the *Options|Labeling* menu, *Rooms* tab. The visibility of all rooms with the *Standard* setting can be changed in this menu.
- **Display:** The room labeling is always visible.
- **Do not show:** The room labeling is not visible

**Rotation:** the rotation angle of the room stamp

**Automatic positioning:** You can have the position of the room stamp determined automatically. However, the position of the stamp can be changed at any time using the mouse. The option is then automatically deactivated.

**Use default font:** If this option is active, the font from the standard settings for room labels from the *Project\Labeling* menu - **Rooms** tab is used. If you deactivate the option, the font for this room can be set individually.

**Font for the name:** Font for the room name

The following options are available:

- **Standard** - Settings from the standards in the *Project\Labeling* menu - **Rooms** tab
- **Custom** - You can define your own font
- **Same as rest** - The name adopts the font of the other texts in the room stamp

**Text frame:** creates a rectangular frame around the entire room stamp. Fill and outline are adjustable.

You have three options:

- **Standard** - adopts the standard setting from the *Project\Labeling* menu - **Roomstab**
- **Do not show** - the frame is never shown
- **Show** - the frame is shown, the settings must be made individually

**Room designation 2 lines**

If this option is activated, designations are continued at the first space in a second line.

**Different composition of the room stamp**

In the *Options\Labeling* menu or *Project\Labeling* - **Rooms** tab, you can set which room properties appear in the room stamps. This default setting can be canceled for each room individually. The visible elements are selected using the corresponding option boxes.

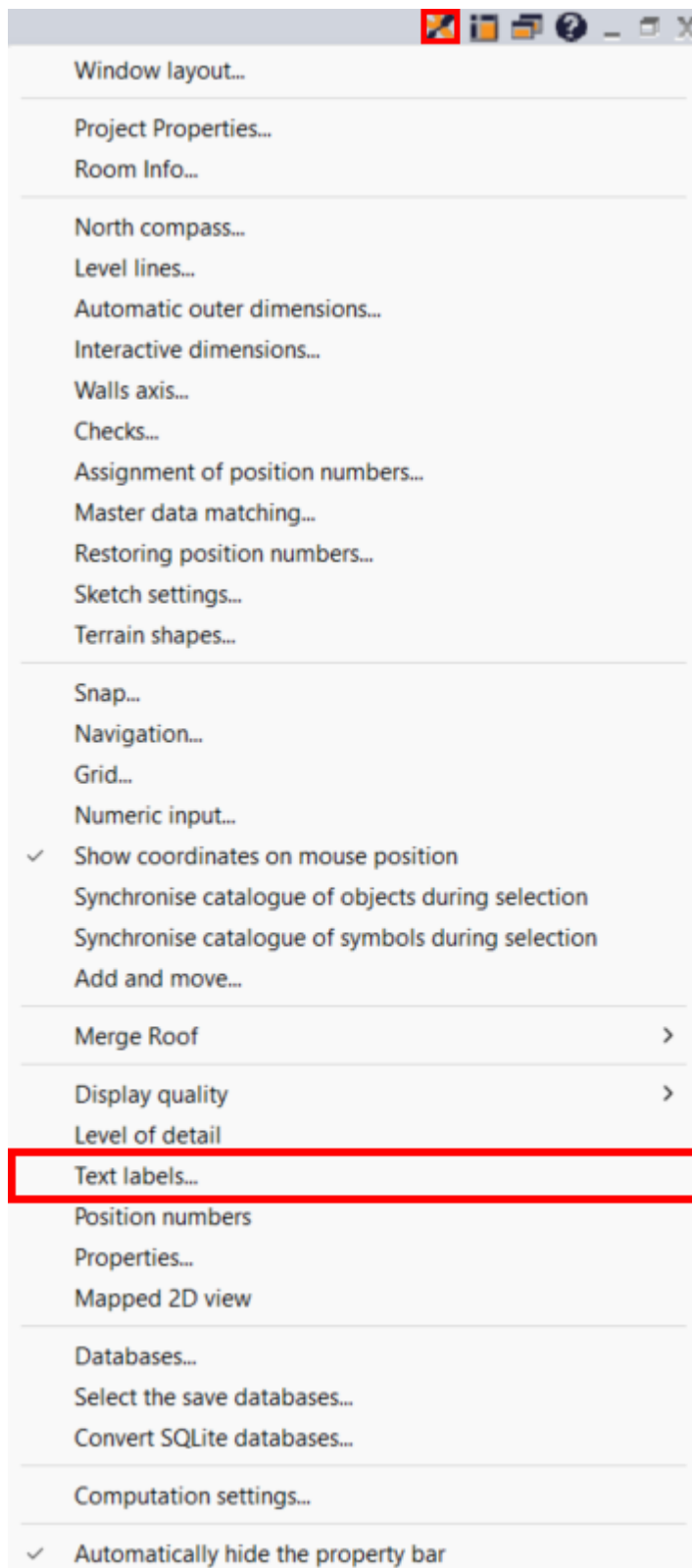

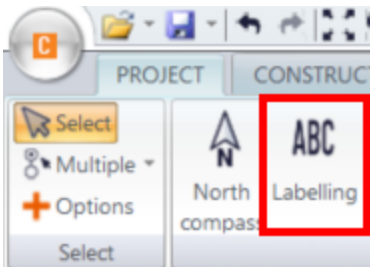

Rooms tab:

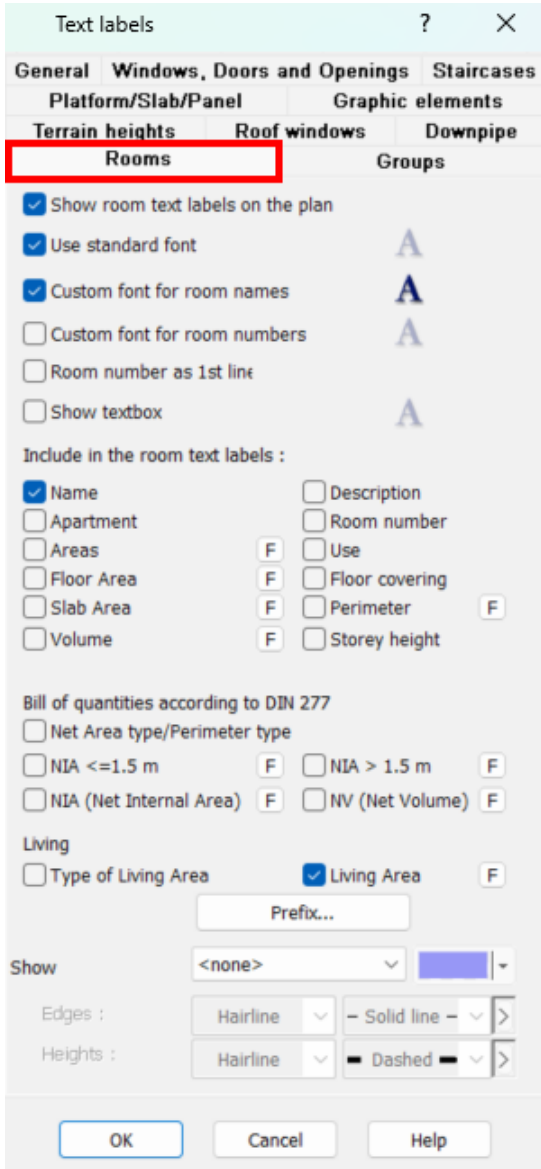

12.17.2.4 Contour

Here you set the line type of the room polygon for the floor plan. The contour of the room polygon is often not displayed (= default value), as the display of lines for doors and floor-to-ceiling windows is not

desired. The *color*, *line width* and *line type* can be changed. The *Fill alternating* property has no effect on rooms, as self-intersecting polygons are never created as room contours. Further information on the [Contour](#)<sup>[138]</sup> properties can be found in the [General properties dialogs](#)<sup>[134]</sup> chapter.

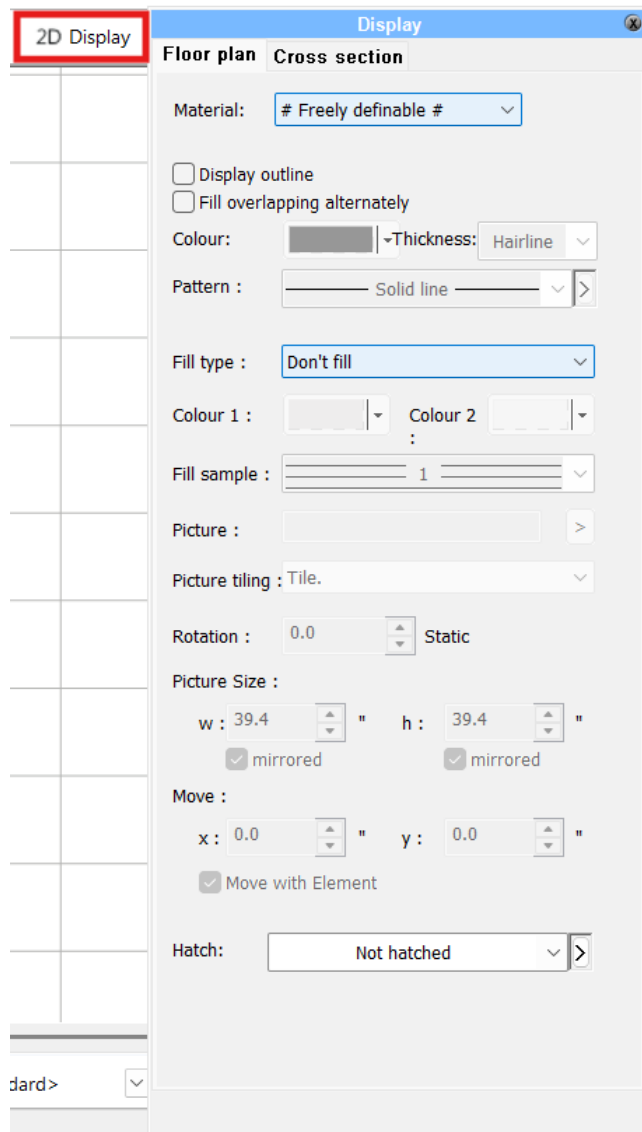

### 12.17.2.5 Filling and Hatching

Parameters for the fill and hatching of the spatial polygon. You can find further information on the [Fill](#)<sup>[140]</sup> and [Hatching](#)<sup>[141]</sup> properties in the [General properties dialogs](#)<sup>[134]</sup> chapter.

### 12.17.2.6 Materials

In this form, you specify the materials for the floor, ceiling and interior roof cladding.

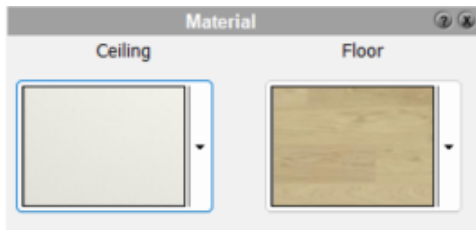

### 12.17.2.7 Levels

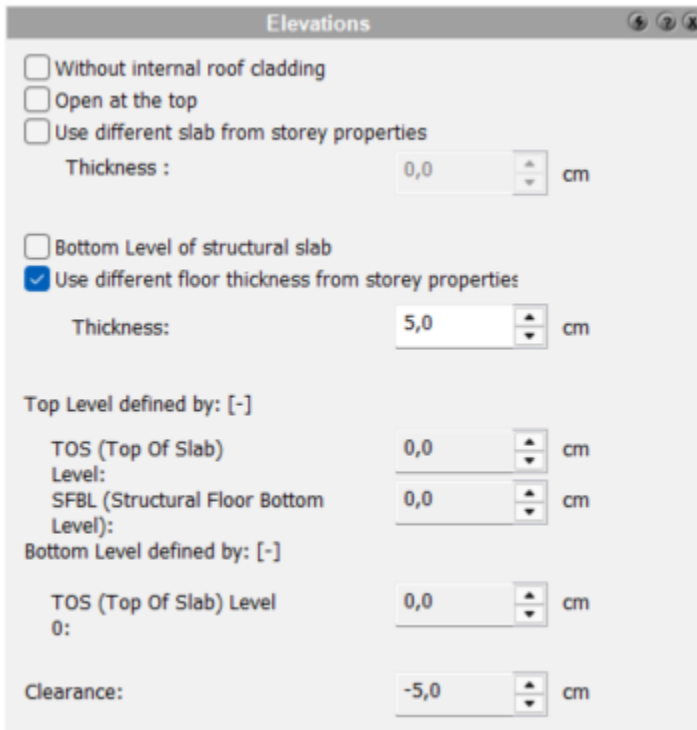

If nothing else is set, a room is displayed at the heights specified by the storey. This dialog can now be used to make different settings.

The options **open upwards/open downwards** hide the ceiling or floor area.

The option **without internal roof cladding** does not show any areas for the internal roof cladding for this room.

The floor structure and suspension of the room can have different values from the storey if the corresponding options are activated.

The height of the room is displayed in the lower section of the dialog.

The upper level is calculated using the upper edge and the lower edge of the ceiling above the room.

The ceiling can either be defined by the storey,

or be drawn in as a free ceiling slab. For free ceiling slabs, the option **Do not trim rooms with ceiling slab** must be switched off.

The lower level is defined via the upper edge of the ceiling below the room.

The dialog shows whether the height of the room is defined by a storey ceiling or a freely drawn ceiling.

The clear height results from the distance between the ceilings and the values for the floor and ceiling suspension.

### 12.17.3 Room stamp

The room stamp is generated automatically. Its layout is determined by the property settings.

Raum 1  
133,55 m<sup>2</sup>

Room properties including stamp can be stored as a new component in the [catalog](#)<sup>388</sup>.

Global visibility parameters are entered here (menu bar **Project|Labeling|Rooms tab**):

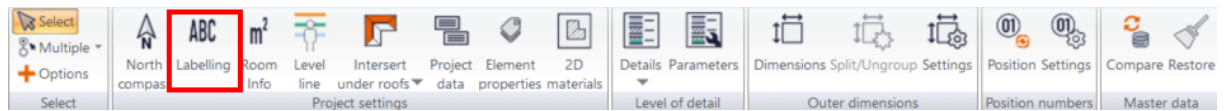

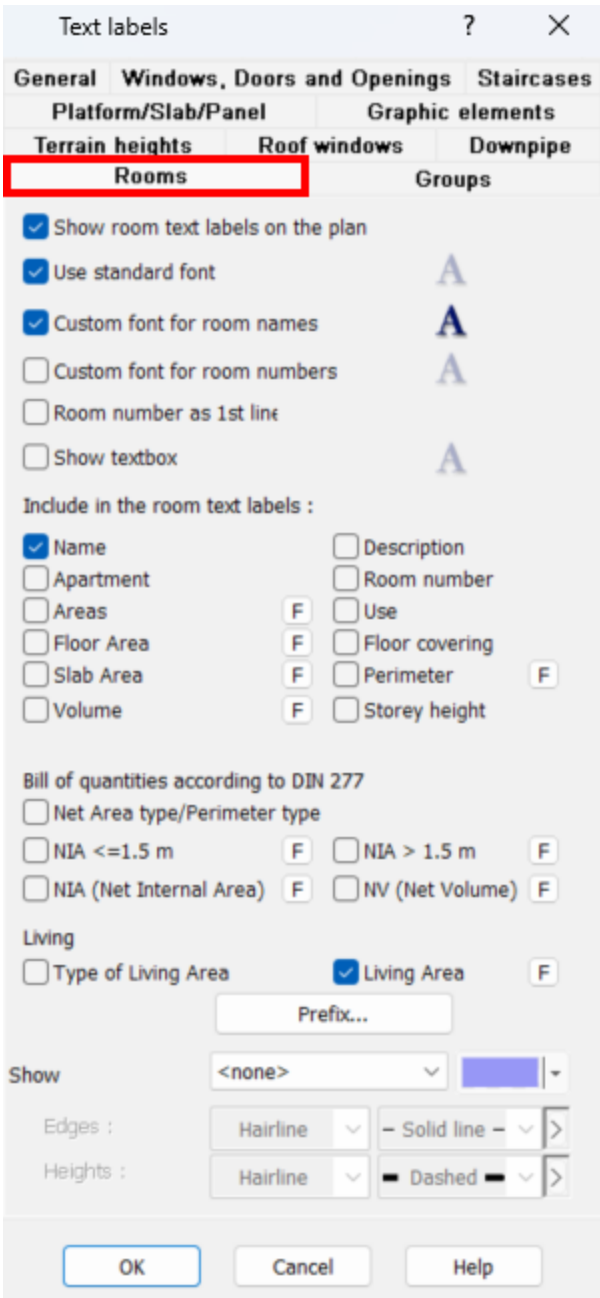

### 12.17.4 Room info

This dialog is selected via the menu bar **Project|Room info...**:

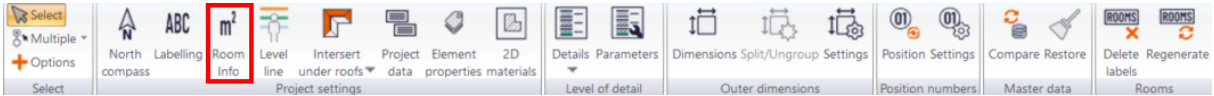

**Room info/DIN277/WoFIV** dialog :

Room info/DIN 277/Livin... ? X

**Room info/DIN 277/Living areas** **Rounding**

Loft areas deduction

Bottom level line

Height: 100,0 cm

Area deduction : 100 %

Top level line

Height : 200,0 cm

Area deduction : 50 %

Use structural dimensions

Deduct standard rate of 3%

Remove chimneys

Minimal Area: 0,0 cm<sup>2</sup>

Area Deduction : 100 %

Columns/Posts/Pillars deduction

Minimal Area: 0,0 cm<sup>2</sup>

Area Deduction : 100 %

Allow for doors

Add windows and openings

If Area is larger than 1000,0 cm<sup>2</sup>

If Depth is larger than : 13,0 cm

Area under staircases Deduct as in the loft stor

Height: 150,0 cm

Ignore all slab openings for Apartment Area and NI

Set with standard values!

OK Cancel Help

In this dialog, specify how the area calculation of the values DIN 277 and according to the Living Space Ordinance should be carried out. The standards are defined according to the applicable regulations and standards.

### ***Rounding*** dialog

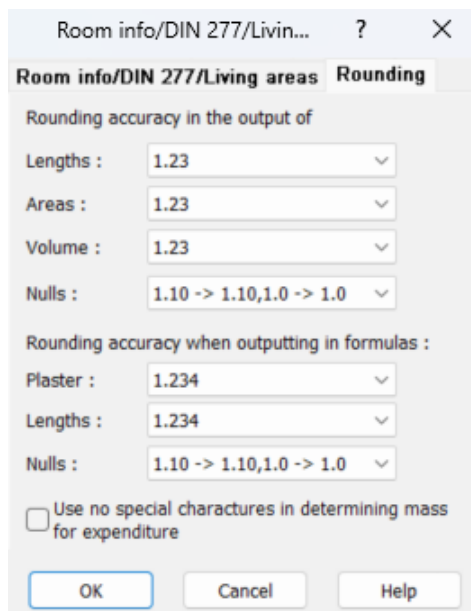

Specify the rounding accuracy for room labels and outputs here.

### 12.17.5 Rounding

This dialog is selected via **Project|Room info**:

**Rounding** dialog

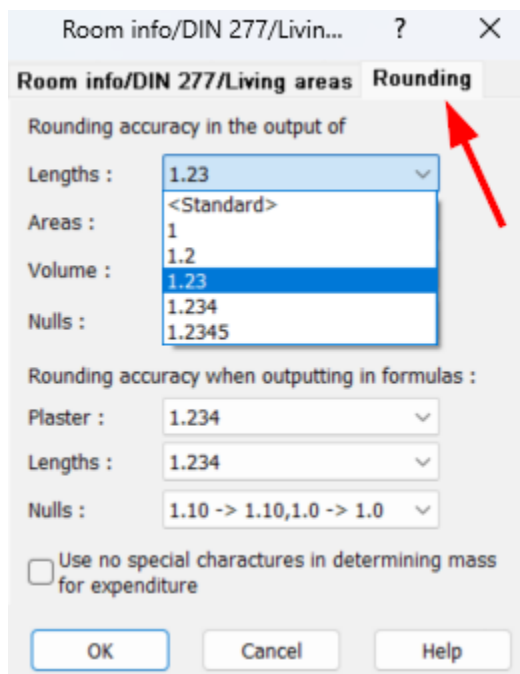

The display of decimal places in the room stamp can be controlled globally here.

### 12.17.5.1 Contour lines

This dialog is selected via the pull-down menu under **Project|Elevation lines...**:

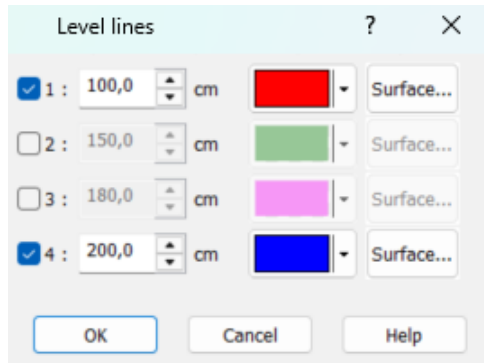
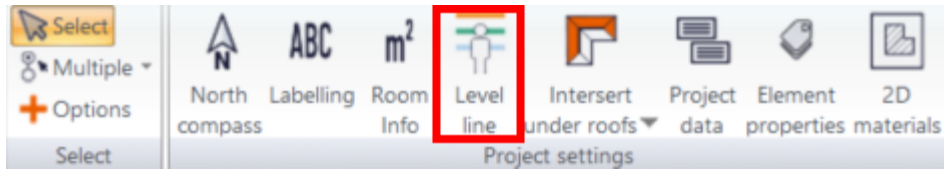

Regardless of the parameters for the area calculation, four contour lines can be displayed in the planning to support the design.

In this dialog, the height position, the color and the planar display of the contour lines are set. The visibility of the contour lines can be selected in the pull-down menu at **Options|Contour lines**.

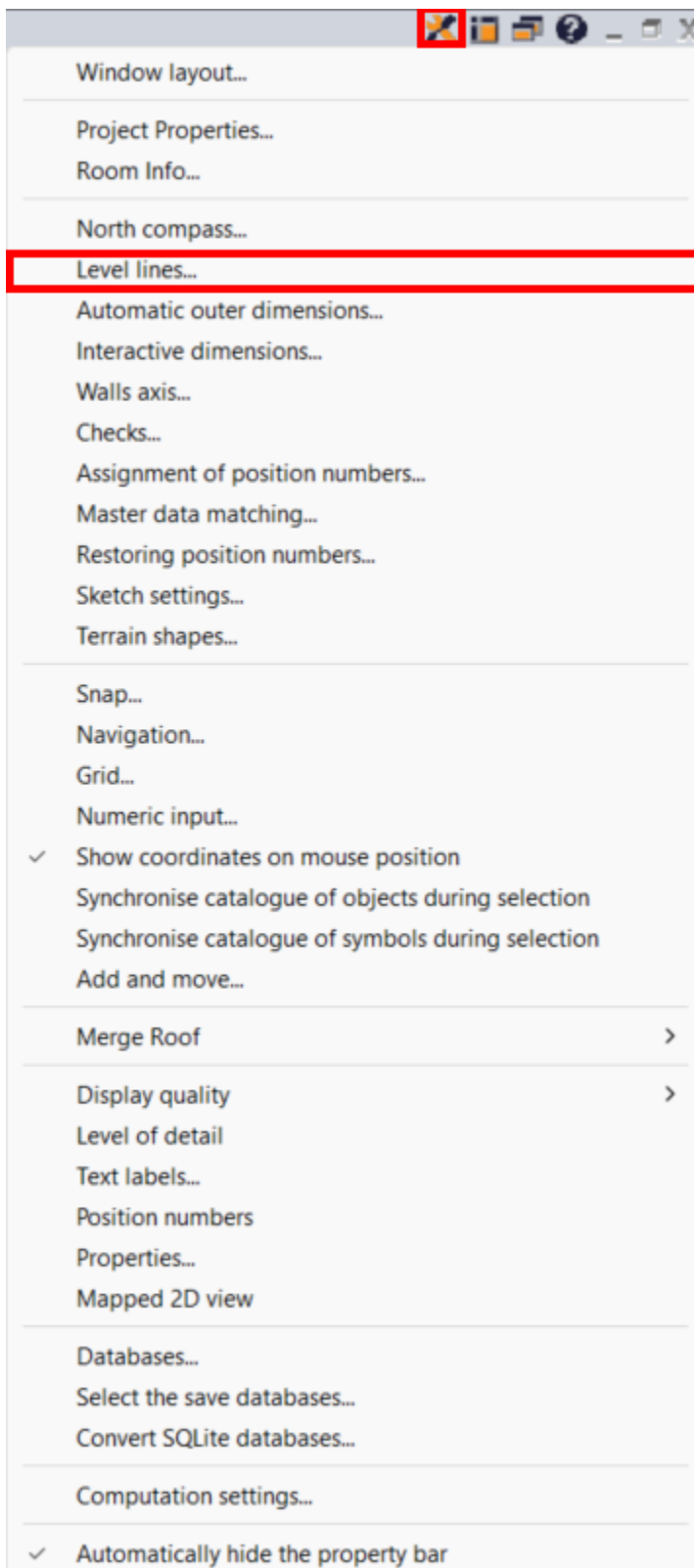

## 12.17.6 Assign rooms

 **Assign rooms** tool.

Use this tool to start entering rooms or assigning master data to rooms that have already been drawn.

1. start the function
2. select a suitable master data entry from the catalog and change the other parameters if necessary.
3. move the cursor over a room and click with the left mouse button
4. the room is assigned. You can assign **several rooms** at once.

You can assign rooms using the corresponding function in the construction bar. A square symbol appears at the mouse pointer, left-click to place it, repeated left-clicks allow you to assign several rooms:

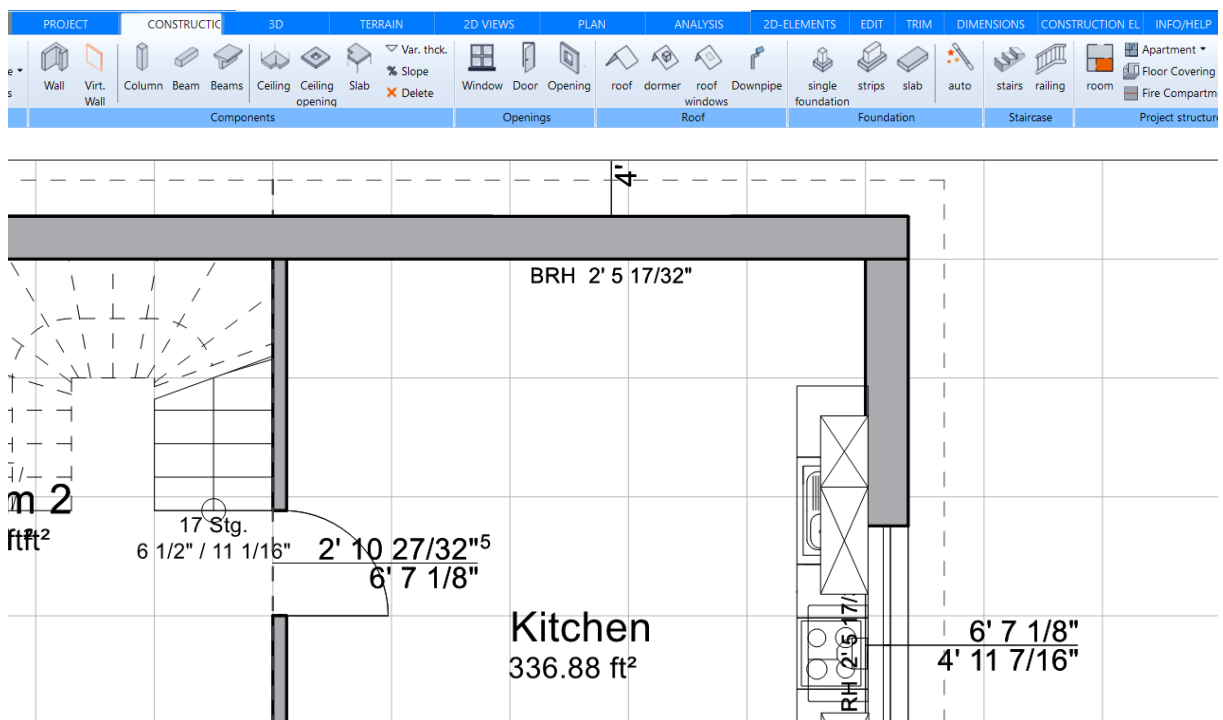

A context menu line now appears with various setting options:

Room :  Kitchen  Apartment <not assigned> Fill colour  Floor covering : <not assigned> Net Area type: UFA1

- 1) Select a room from the **catalog**
- 2) Assign a **room** name (e.g. "Kitchen")
- 3) **Apartment:** Assign the room to an apartment from the drop-down field or create a new apartment
- 4) **Fill:** Assign a fill color to the room by selecting a color with the mouse, the square box next to the mouse pointer now appears in the selected color, now click with the mouse in the room to which you want to assign the color. Multiple assignments are also possible here:

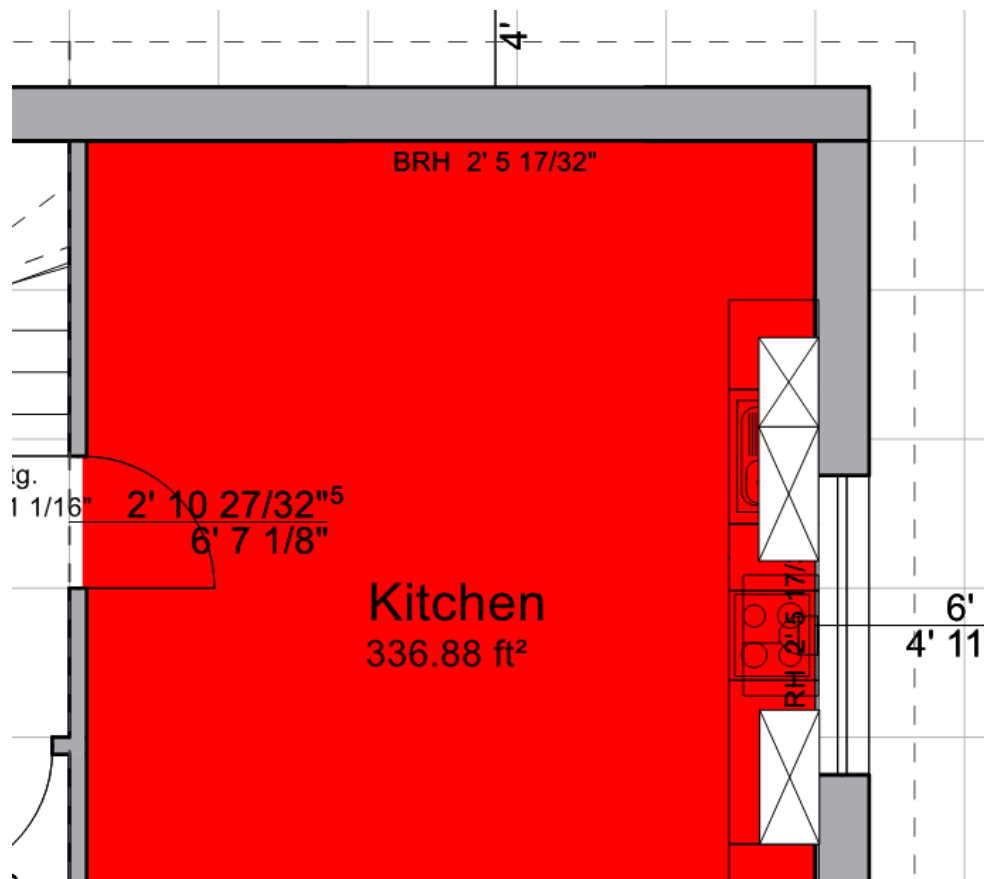

### 12.17.7 Assign apartments

Assign apartments tool.

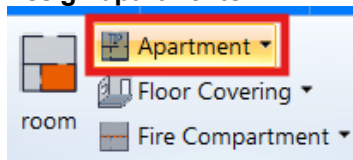

The procedure is similar to that for assigning [rooms](#)<sup>402</sup>. In the same way as rooms are displayed in color, apartments can be displayed in color here:



### 12.17.8 Unbound rooms

The unbound rooms function was developed so that the room data already entered is not lost again during construction as soon as a room contour is opened either intentionally or unintentionally. If you draw a closed room contour, a room bound to this contour is automatically created.

If this contour is opened, for example by moving a wall, the room is transformed into an unbound room. Its contour is displayed as a rectangle and the area = 0. If the contour is closed again, the bound space with all its properties is created again.

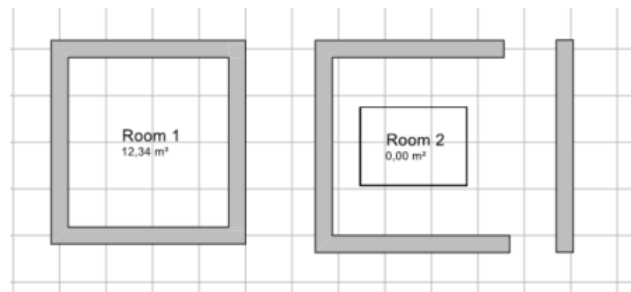

The position of bound rooms is fixed by their outline; only the room text can be moved. Unbound rooms can be deleted, copied and moved.

If you move an unbound room into the outline of a bound room, it takes on all the properties of the unbound room.

An option in the **File|Settings|Program** settings tab can be used to specify that no unbound rooms are to be created.  
When a contour is opened, the bound rooms are deleted and the information is lost.

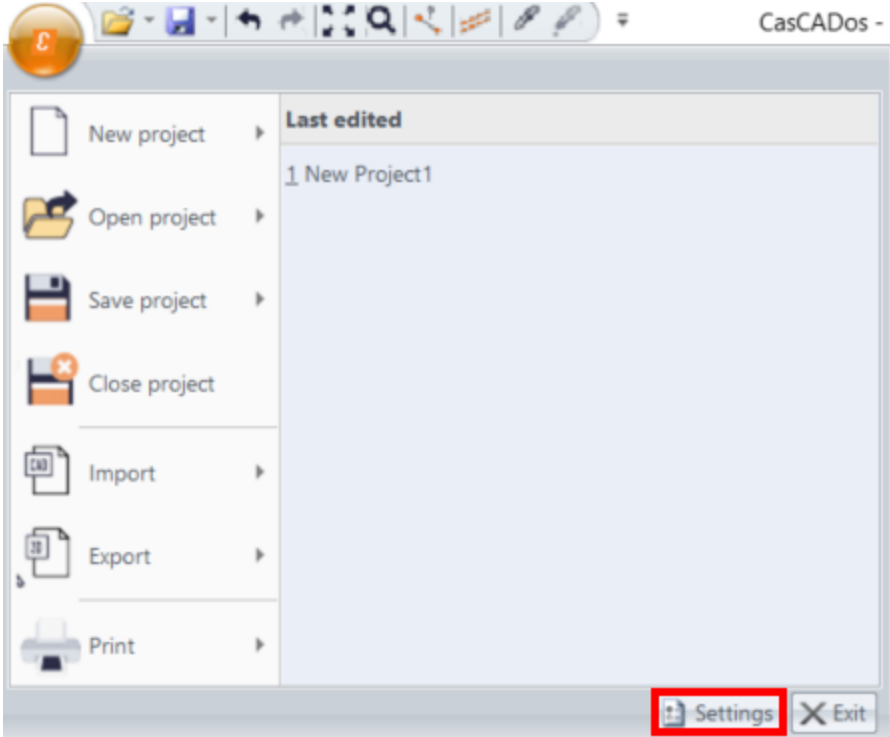

Check the **"Do not create unbound rooms"** box:

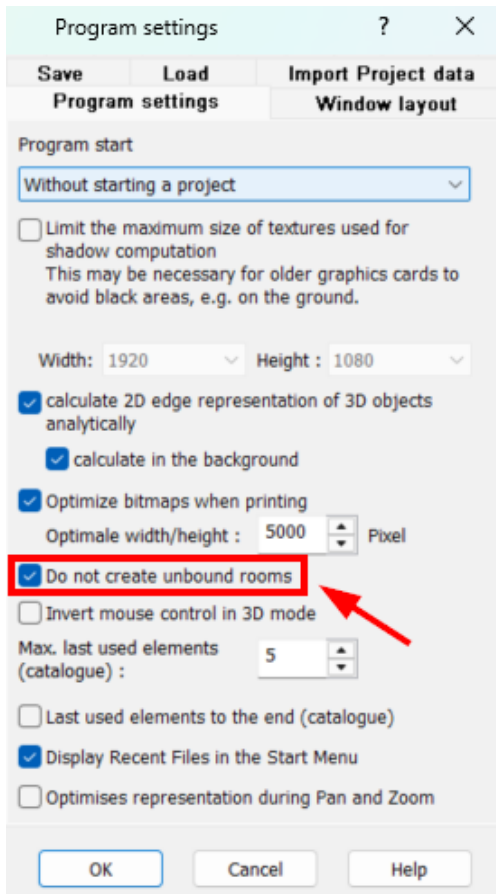

This setting then applies to this workstation, for all projects.

All unbound rooms can be deleted with the Alt+R shortcut key or via the **Project>Delete unbound rooms** function.

### 12.17.9 Copy rooms

Rooms can be copied very easily. The desired room is selected and copied using the context menu with the right mouse button:

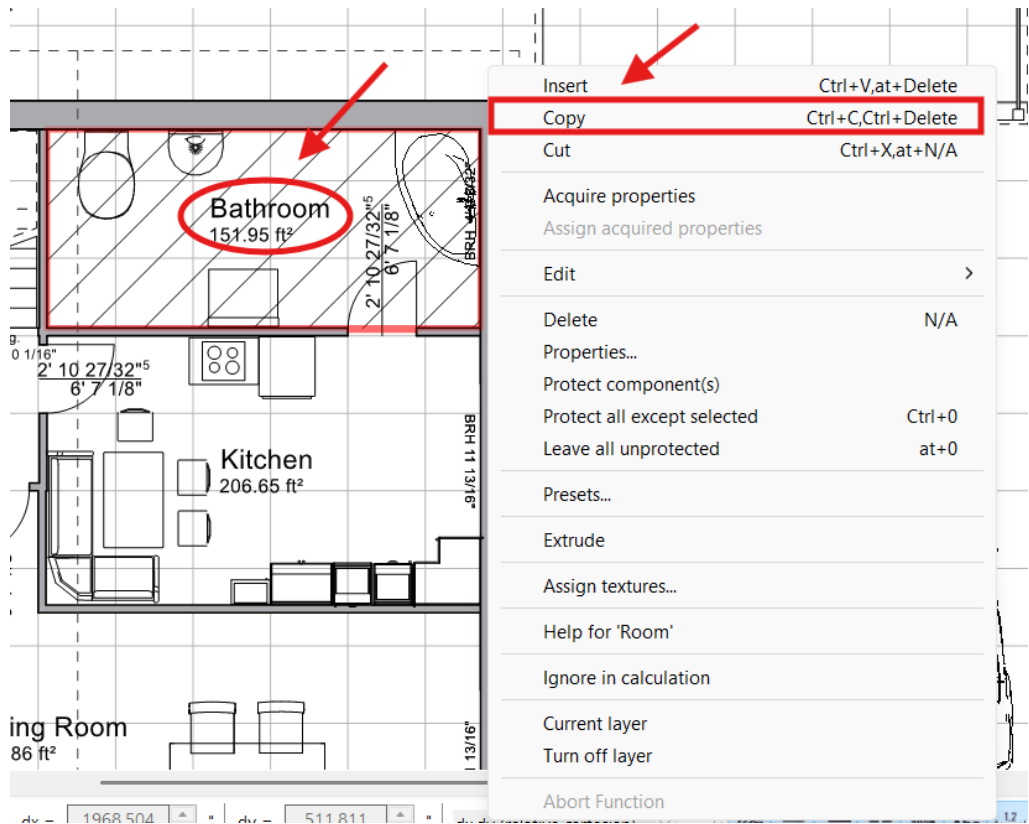

The room to be copied now moves with the Cirsor (even outside the planning) and can be dropped at any location by left-clicking with the mouse (click on the room name of the target room):

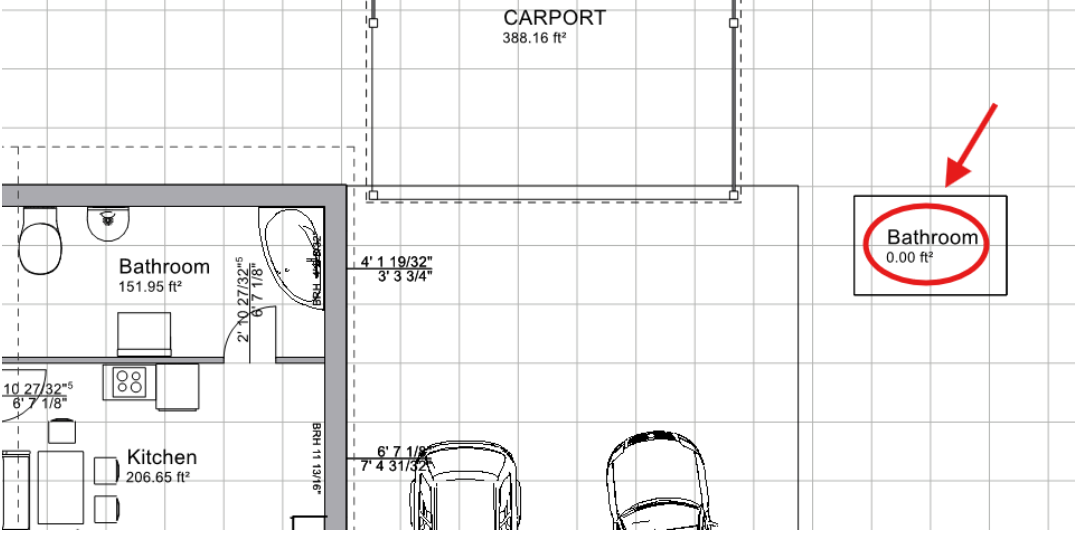

## 13 3D-Modus

In 3D mode, the entire model or parts of it (depending on the setting) are displayed in 3D.



### 13.1 Navigation in 3D mode

#### Zoom scroll wheel

Roll the scroll wheel forwards to enlarge the display. The cursor position determines the center of the magnification.

Roll the scroll wheel backwards to zoom out. The cursor position is also used as the center here.

#### Turning the scroll wheel

Hold down the scroll wheel and move the mouse. The model now rotates around the cursor position, i.e. the viewer position is rotated around the center.

The center of the rotation can be moved by zooming to another point with the scroll wheel

If you also press the **[Ctrl]+** key, the model is moved on the screen.

#### Cursor keys

You can use the cursor keys to move forwards (in the direction of the mouse cursor) or backwards, to the left or right. If you also hold down the **[Ctrl]+** key, the display rotates around the viewpoint.

#### Sections

You can define any number of sections in the **View** menu. The current viewpoint and the perspective settings are saved.

Create a new section in the menu under **View|Section|New**

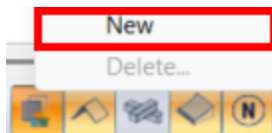

Now enter a name for the section and define the view options:

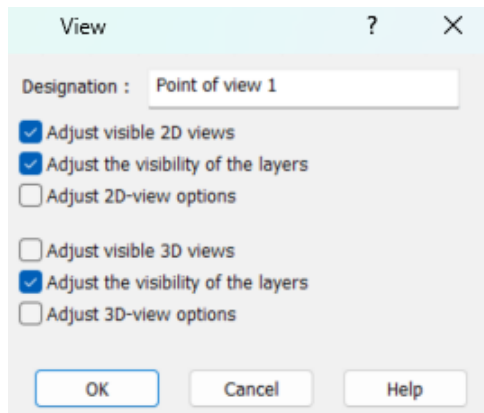

A saved section can be called up in the **View|Section** menu. Sections that are no longer required can be removed again in the **View|Section|Delete section** menu.

## 13.2 Perspective

In this dialog, the parameters of the perspective can be changed by entering values. Open this dialog in the menu bar under **View|Perspective...**



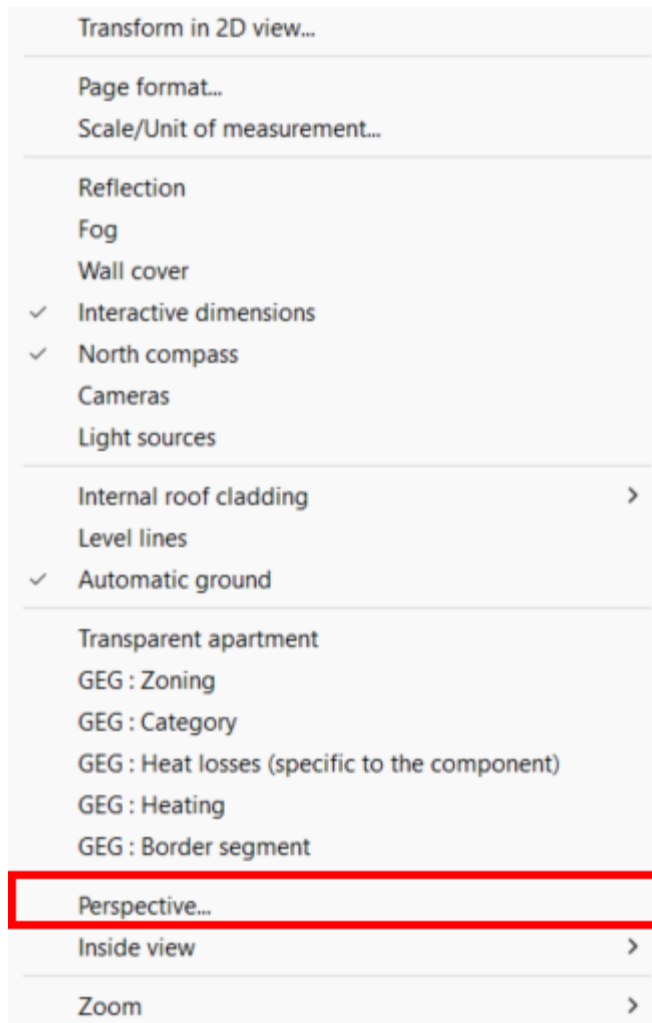

The following options are now available:

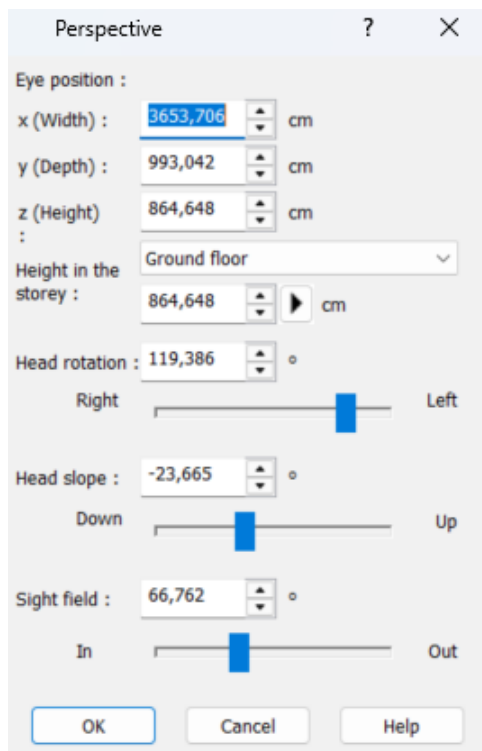

The changes are only applied after closing the dialog.

#### Options:

Position of the eye:

X (width)

y (depth)

z (height)

Height in the projectile

Head rotation

to the right/left

Head tilt

downwards/upwards

Field of vision

narrow/wide

### 13.3 Display quality

The *display quality* can be set in 3D mode in the *View* menu.

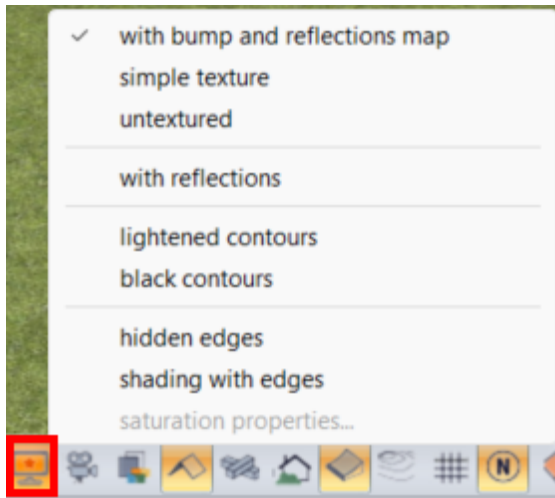

Please note that the setting has a major impact on the display speed, especially with older graphics cards.

Therefore, select a simpler display during editing and only switch to a higher quality during output.

### 13.3.1 with bump and reflection map

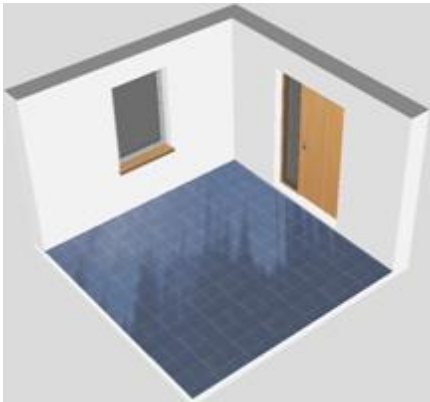

The highest display quality with textures. Bump maps and reflection maps are also shown. This display also requires a lot of graphics performance, but is ideal for the final output of images and videos.

### 13.3.2 Simply textured



No bump and reflection maps are shown in this display. Reflections can be switched on optionally. This display method is recommended for editing.

### 13.3.3 Untextured

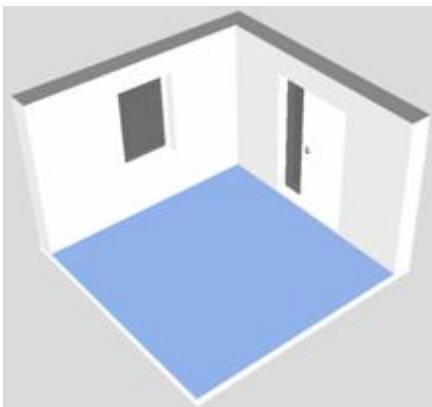

No textures are shown. The colors shown are generated from the color settings of the materials.

### 13.3.4 Illuminated contours

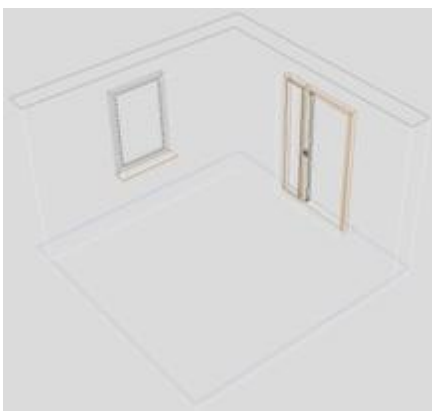

Wireframe representation with colored contours.

### 13.3.5 Black contours

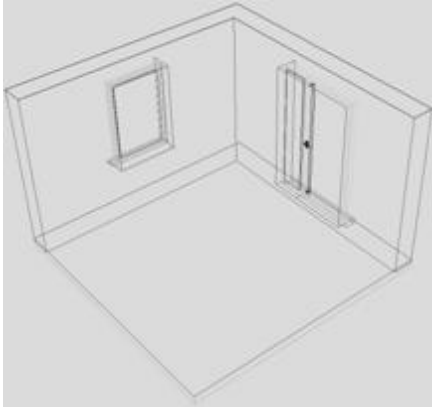

Wireframe representation with black contours.  
This representation is helpful for visually checking the 3D model.

### 13.3.6 Concealed edges

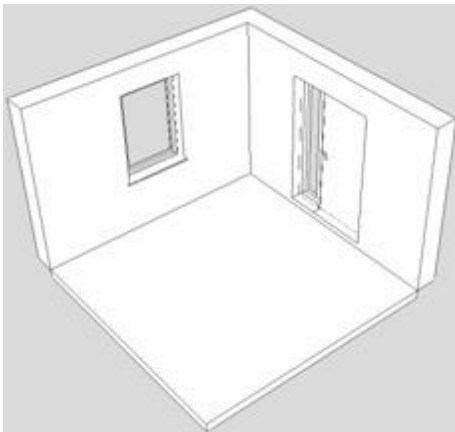

The display with hidden edges in 3D mode. The calculation is always automatic, but this can lead to a slightly delayed display for more extensive models. Please note that this display (but also with a more precise calculation of the hidden edges) is also possible as a 2D view.

### 13.3.7 Shading with edges

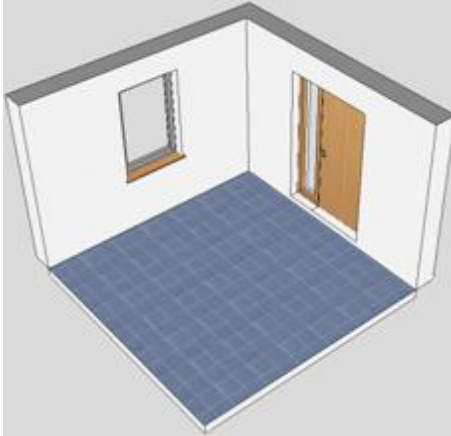

The display with hidden edges and colors/material in 3D mode. The calculation is always automatic, but this can lead to a slightly delayed display for more extensive models. Please note that this display (but also with a more precise calculation of the hidden edges) is also possible as a 2D view. The saturation of the colored shading can be adjusted.

## 13.4 Background

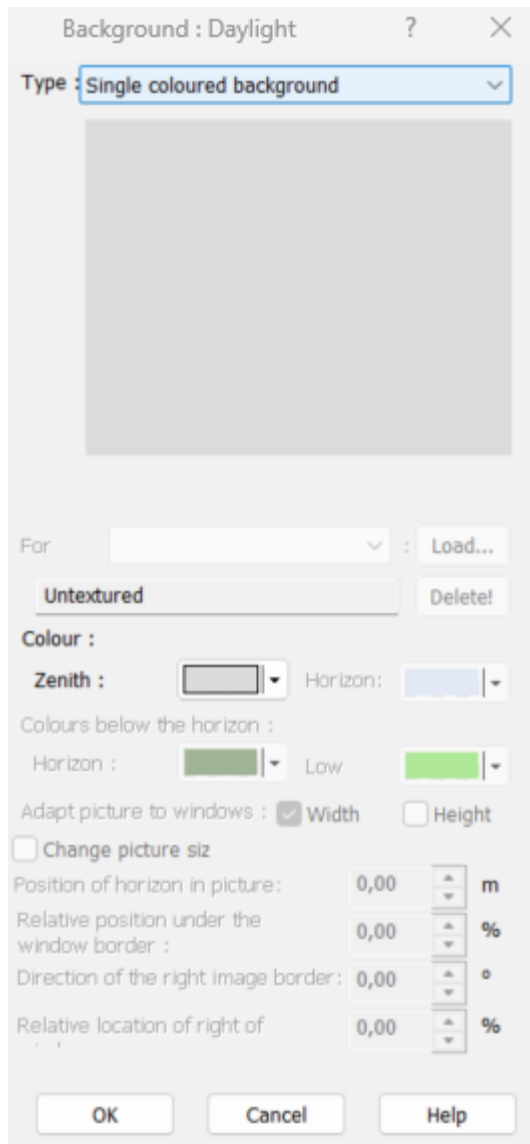

In the **3D Explorer** | **Background**  ...

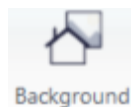

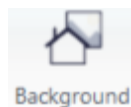
or via this icon:  (under Settings in 3D mode) you can change the display of the background in 3D mode. The settings are always for the current time of day (day, night, time-dependent).

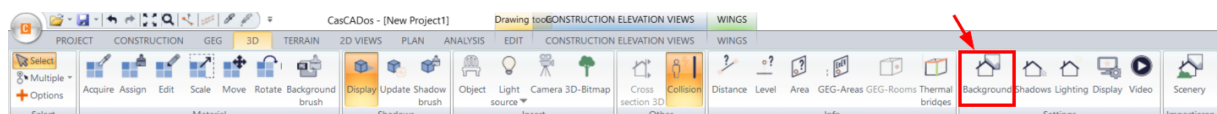

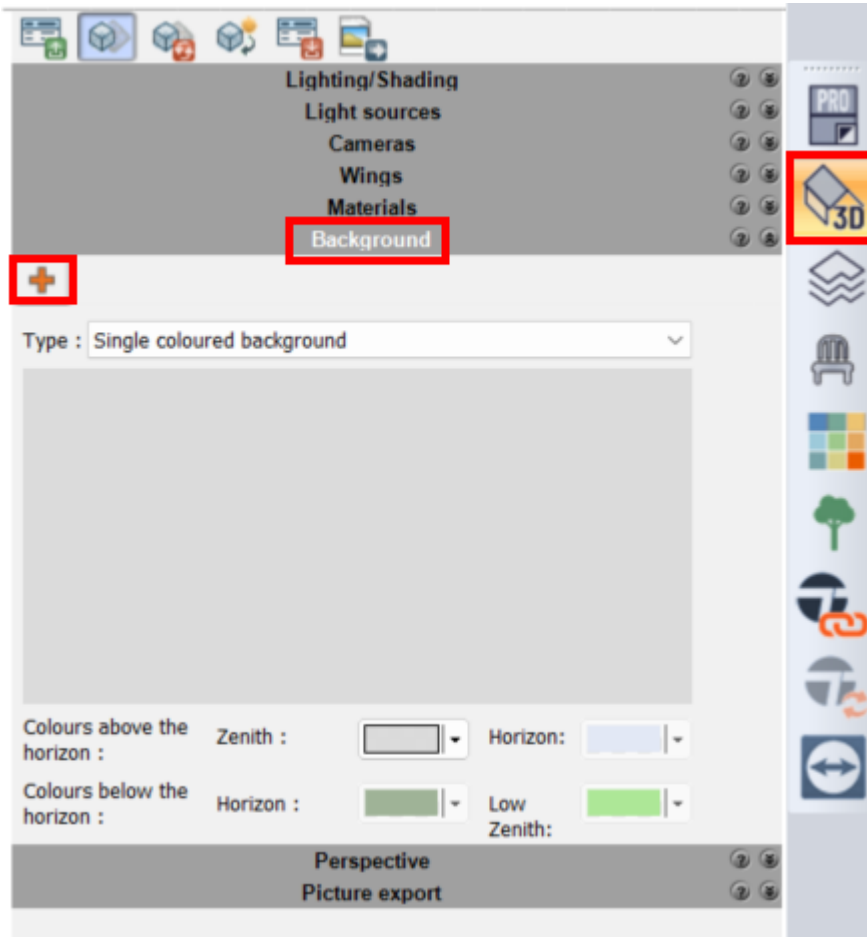

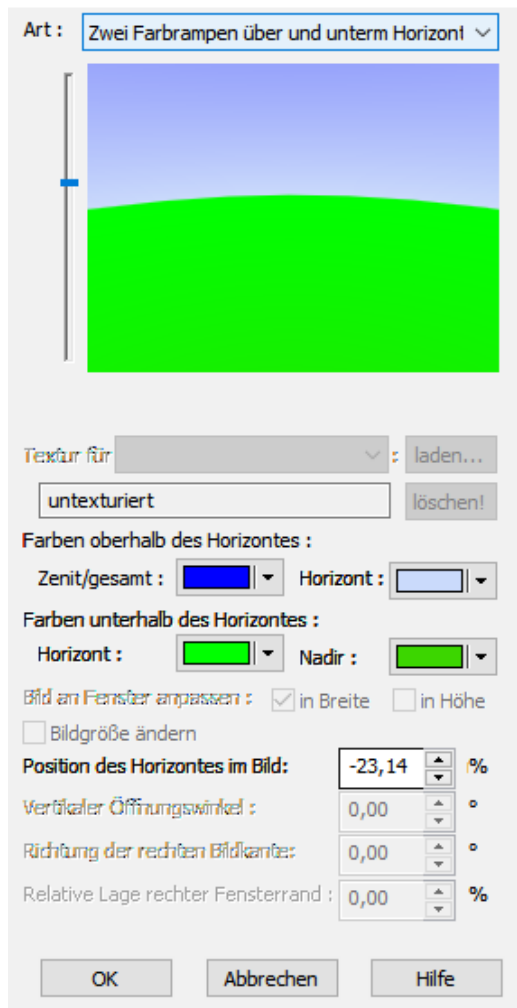

The background of the 3D display is configured in this dialog. Each time of day, i.e. **day**, **night** and **variable**, manages its own background. The type of background can be defined as:

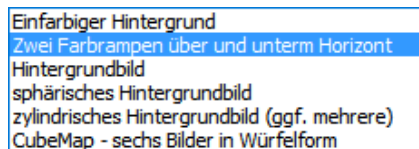

**Single color background:** One color is shown constantly over the entire area.

**Two color ramps above and below the horizon:** A total of four colors are defined. The sky is displayed as a color gradient from the zenith to the horizon. The terrain is also shown as a color gradient from the nadir to the horizon.

**Background image:** Load an image file. The width and height of this image file can be adapted to the screen resolution. The image will be distorted. The image size and the relative position of the edges to the edge of the screen can be changed. All areas of the section that are not covered by the image can be assigned a color.

**Spherical background image:** Works in a similar way to the normal background image. However, the image is not applied to a plane but to a hemisphere. This enables a realistic representation of the surroundings when walking through the scene, but requires special 360° images of the surroundings.

**Cylindrical background image:** Like spherical background image, but displayed as a cylinder. Optionally, several image files can be used.

**Cubemap:** A cube is shown as the basis for the background. An image can be loaded for each side of the cube.

## 13.5 3D cut

### 2D cut

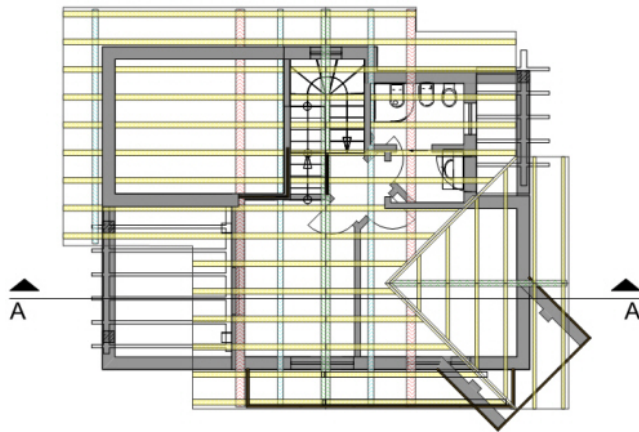

### 3D cut

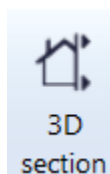
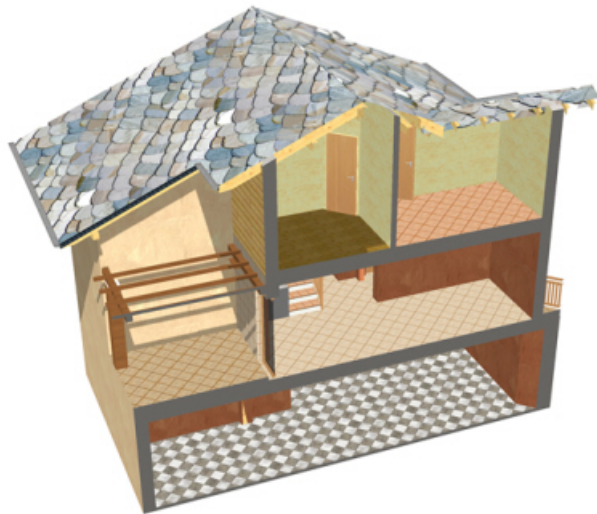

Sections can also be displayed in 3D mode. Clicking on the **3D cut** button  takes you to the list of sections in which you can make your selection. Further information can be found at [cut](#)<sup>483</sup> in the **2D views** chapter.

## 13.6 Collision control

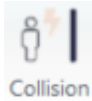

The button on the top toolbar only has an effect when moving through the apartment. If the button is not pressed down, you can move through your home as if you were "material-free", i.e. you can walk through walls and furniture without any problems.

## 13.7 Catch

### The dialog

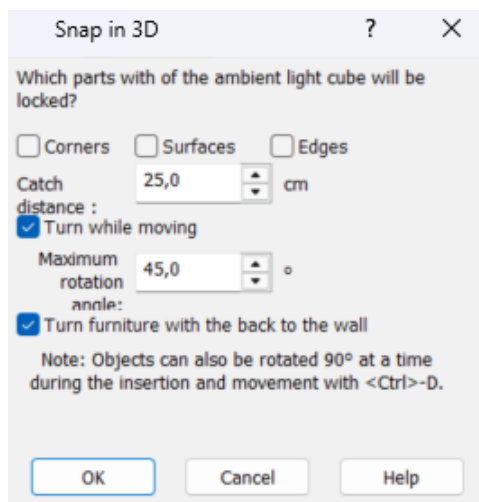

The dialog is opened under pull-down menu **Options|Catch...** in **3D mode**.

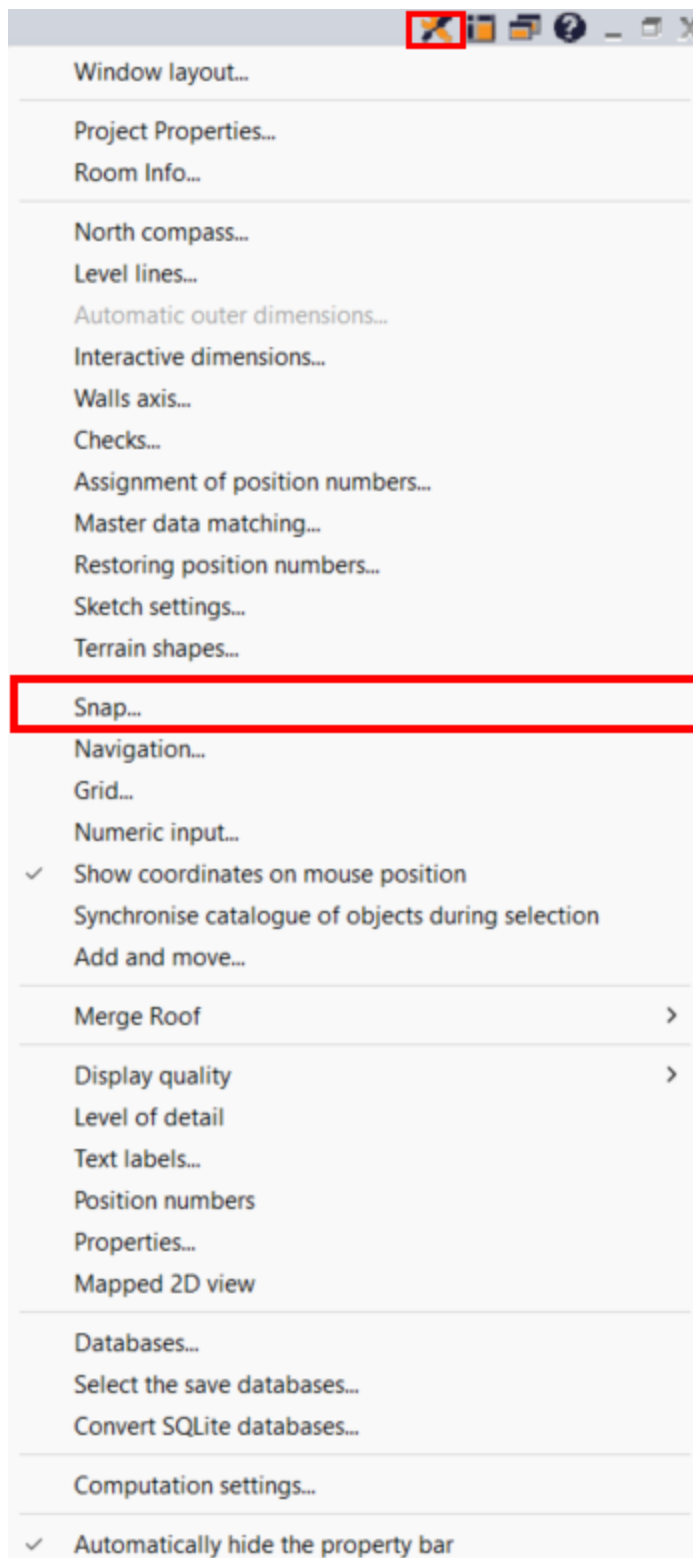

## 13.8 Measuring in 3D mode

Using the **Measure surfaces** button in 3D mode, you can measure surface areas very easily with a single mouse click.

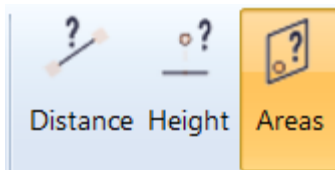

To do this, after activating the **Measure** areas button (a tool symbol now appears on the mouse pointer), left-click on any area in the 3D model:

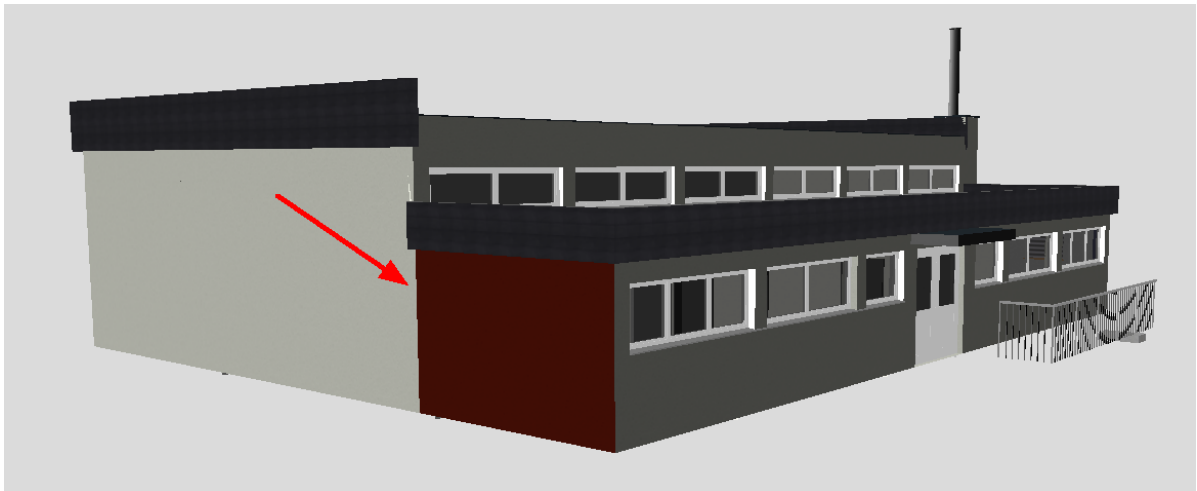

The selected area is now highlighted in color and a window appears in which the measured area is displayed:

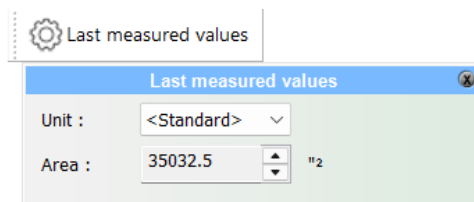

Under Unit, you can select the desired numerical unit (metric/Anglo-American system) from the drop-down list.

Switch to the construction level with the button **CONSTRUCTION**, then switch to the dimensions level. Here again you will find the Measure button.

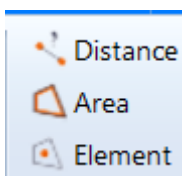

If you now measure the façade area above the window front, for example, after pressing the **Measure area** button, not only the area is displayed, but also the width, height and circumference.

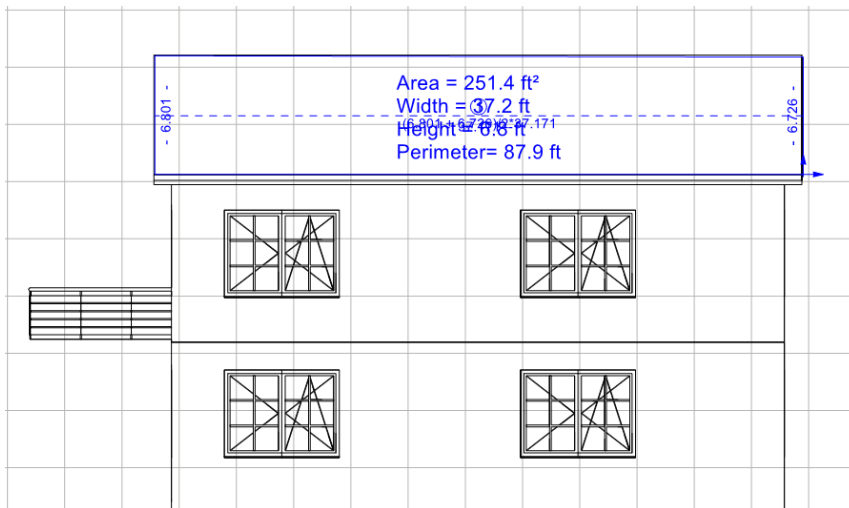

In 3D mode, you also have the option of measuring **distances and height**. The functions for this can be found on the menu bar under the measuring tools:

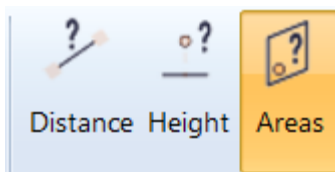

To measure a **distance** in 3D mode, click on the **Measure distance** button, the cursor will now turn into a small red ball, click with this on the starting point of the distance to be measured, a blue distance symbol will now appear, click again to define the end of the measured distance:



When the measurement is complete, a window appears showing a summary of the measured values:

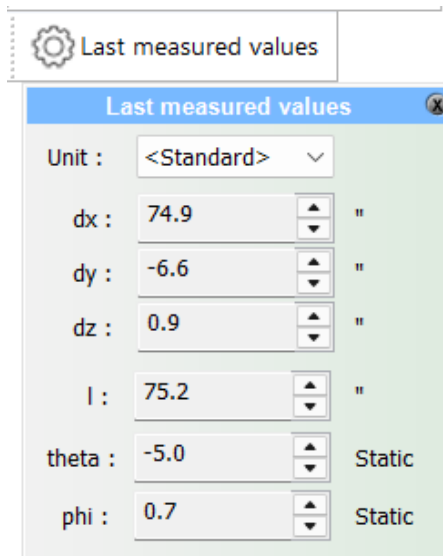

The unit of measurement can be selected as required from the drop-down field, the default unit is cm. If the unit of measurement is changed, the measured values are automatically converted.

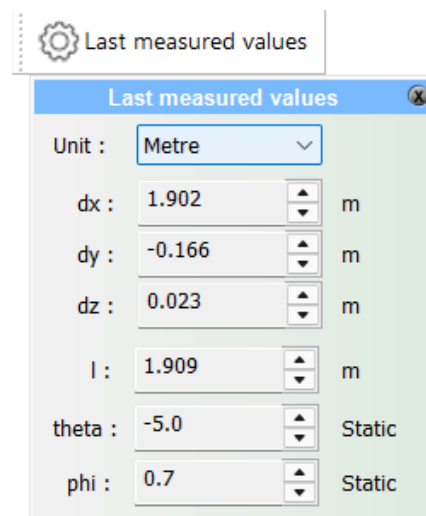
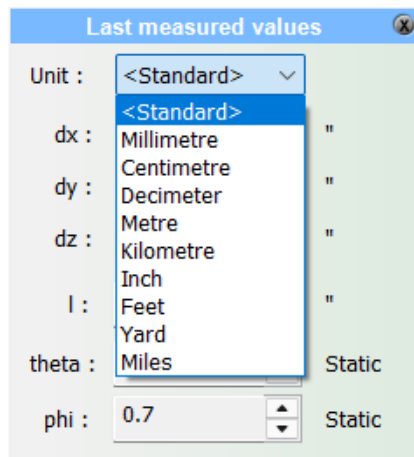

To determine a specific **height and position** in 3D mode, click on the **Determine height and position** button , the cursor will now turn into a small red ball, click on the component whose height and position you want to determine.



Once the measurement is complete, a window appears showing a summary of the measured values:

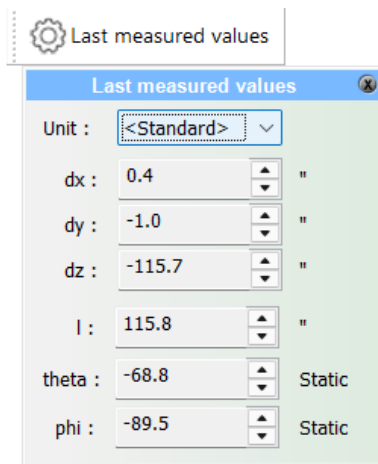

The unit of measurement can be selected from the drop-down field, the standard unit is cm. If the unit of measurement is changed, the measured values are automatically converted.

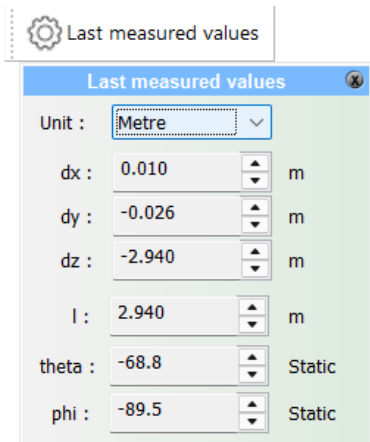

## 13.9 Light and shadow

### 13.9.1 General information

A good picture always depends on the perfect lighting of the scene. Naturally, there can be no one-size-fits-all guide to ideal lighting. The requirements and starting situations are simply too different. The simplest and quickest way to light a scene is with daylight from the sun. However, if you have time, we recommend experimenting with light sources and their parameters. You will achieve great improvements in display quality.

#### 13.9.1.1 Light components

We distinguish between three light components: Ambient light (ambient component), diffuse light and specular light (specular, reflective component).

These light components are used for daylight and for each freely positioned light source in night vision. In addition, values for these light components are set for all materials in order to define the reaction of the material to this light.

The general rule is

$$\begin{aligned} \text{Luminance} = & \text{ambient light component} \\ & + \text{diffuse light component} \\ & + \text{specular-reflective light component} \end{aligned}$$

The total brightness of the surface is therefore the sum of the three light components.

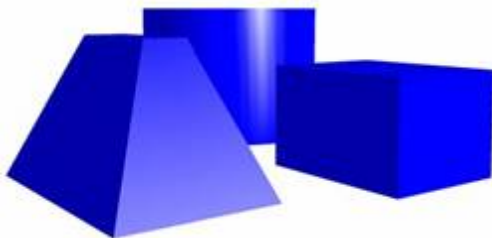

All three light components are shown in the picture on the left.

##### 13.9.1.1.1 Ambient light (ambient light)

This is the proportion of light that comes evenly from all directions. When it hits a surface, it scatters evenly in all directions.

Only objects illuminated by ambient light are always illuminated in exactly the same way on their surfaces. The brightness of all surfaces is directly proportional to the light intensity.

Uniformly illuminated body surfaces are typical of ambient light.

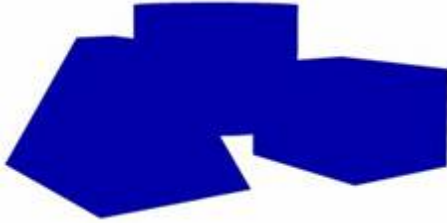

The picture above only shows the ambient light component.

If a room is indirectly illuminated, this light has a high ambient light component. A spotlight outdoors, on the other hand, has a very small proportion because, firstly, large parts of the light are directed and, secondly, due to the open terrain, only a small amount of scattered light reaches the observer's eye.

#### 13.9.1.1.2 Diffuse light

Diffuse light is the light component for materials that depends on the position of the light source in relation to the illuminated surface. An object that is illuminated by a light source whose light rays run evenly in all directions from a single point varies the brightness on its surface.



The image above shows the diffuse light component.

The brightness of a surface depends on the angle of incidence of the light. If the light source is positioned exactly vertically above a surface, it is illuminated to the maximum. If diffuse light hits a surface, it is scattered evenly in all directions. As a result, it always appears uniformly bright, regardless of the position of the observer.

#### 13.9.1.1.3 Highlight

In addition to ambient light and diffuse light, specular light is the third component of the lighting model. This light comes from a specific direction and is reflected by surfaces in a predefined direction. Bare metal and plastic have a high value of specular component, while dull or matt materials such as wood have a low value. Specular highlights allow the viewer to see a bright highlight on the object because the light from the light source is reflected in the direction of the viewer.

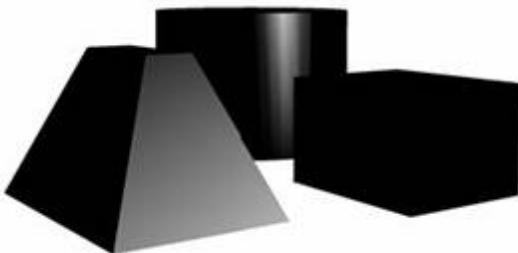

The picture above shows highlights.

#### 13.9.1.1.4 Self-luminous

Independent of all light sources, a material can be displayed as self-illuminating, i.e. the set color is shown by the non-illuminated surface. This light component is added to the three other light components. Self-illuminating materials are rarely used, for example billboards, etc.

### 13.9.1.2 Light and material

Concrete materials react differently to the influence of the three light components. The correct, realistic representation of materials such as metals, wooden surfaces or carpets is achieved in their material properties with the corresponding values.

Each light component of the light source(s) is multiplied by the light component factor of the material.

Here is an example:

All values in this example are given as a percentage for the sake of simplicity. However, the light components themselves are always specified in the RGB or HLS color space. The value range includes values from 0 (0%) to 255 (100%). All values set to 0 correspond to black, all values set to 255 correspond to white. You can find more information in the *Basics chapter*.

There is one light source in the project, a point light.

The light components are defined as

Ambient light 20%

Diffuse light 60%

Glow light 40%

In this project, a cube with material is shown, the light properties are

Ambient light 50%

Diffuse light 100%

Specular light 50%

The material is displayed with:

Brightness of all surfaces, regardless of orientation (= ambient light)

50% of 20% = 10%

The diffuse light adds a maximum, i.e. for the side oriented directly towards the light source

100% of 60% = 60%

The brightest side therefore has 70% of white, the others are darkened proportionally to the orientation, to a maximum of 10% for the side opposite the light source.

The proportion of specular light is also added at eye point positions where the light source is reflected.

50% of 40% = 20%

The brightest surface appears at this particular position with 90% of white.

## 13.9.2 Light sources

### 13.9.2.1 General information

There are two basic ways of using light sources in Plan7Architect. The first option is automatic illumination with sunlight or moonlight. The second option is individually positioned light sources. With day vision, the sunlight is switched on. If you switch to night vision, only the moonlight is active. The time of day can be changed in the *View|Time* menu.

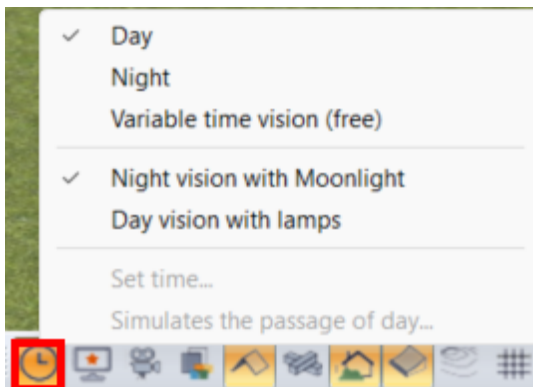

### 13.9.2.1.1 Sunlight

Sunlight is a **directional light source**. Individual settings can be made in the **Settings|Lighting** menu (see **Light settings**).

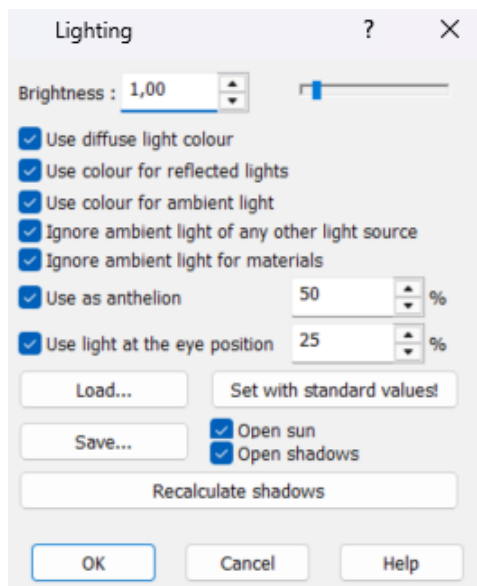
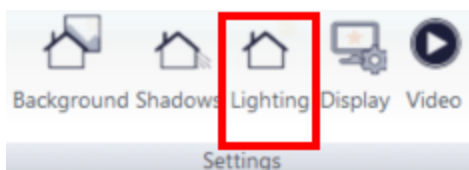

In addition, the geographical position can be recorded as a vertical and horizontal angle. These parameters influence the position of the directed sunlight. In addition, an optional counter sun and a light above the viewer's position can be used. The counter sun has 50% of the diffuse light of the sun, but no ambient light.

The **counter** sun enables an automatically spatially well contoured display.

The light above the viewer's viewpoint always hovers slightly above the eye point of the current 3D perspective and ensures better illumination of the areas currently being viewed. This light also has no ambient component.

A special method of using light is **moonlight**. It is displayed with RGB (60/60/60) and has no diffuse and no shining light component.

## 13.10 Material

### 13.10.1 Introduction

Materials are defined in Plan7Architect as a combination of textures and colors. Textures are used as texture maps, bump maps and reflection maps.

Homogeneous colors are entered without textures directly via the color values in RGB or HLS.



A **texture** is a bitmap that is applied to a 2D or 3D object using a process called **texture mapping** in order to create a realistic scene. The advantage of a texture is that different details of a scene no longer have to be represented with many individual surfaces, but instead a detailed image is stretched over a single polygon.

If areas are covered with material that shows a texture, the brightness of the texture is changed by the light components of the material. The color and structure of the texture are retained.

**Bump mapping** is a special version of texture mapping. It gives the impression that a texture is not smooth and unnatural, but has a rough or structured surface.

**Reflection maps** offer a simple way of simulating reflective surfaces. If a material with a reflection map is applied to a 3D model, the texture of the reflection is mirrored in the model's surface, regardless of the environment. For a realistic reflection, the scaling of the texture and the proportion of reflection must be taken into account.

### 13.10.2 Materialexplorer

The material explorer is displayed in 3D mode with the  button in the explorer bar. The content is divided into folders and sub folders. All folders are marked with the symbol . Materials only show the preview image.

The view of the content area can show small or large preview images.

Switch between the two options using the button  *Details*.

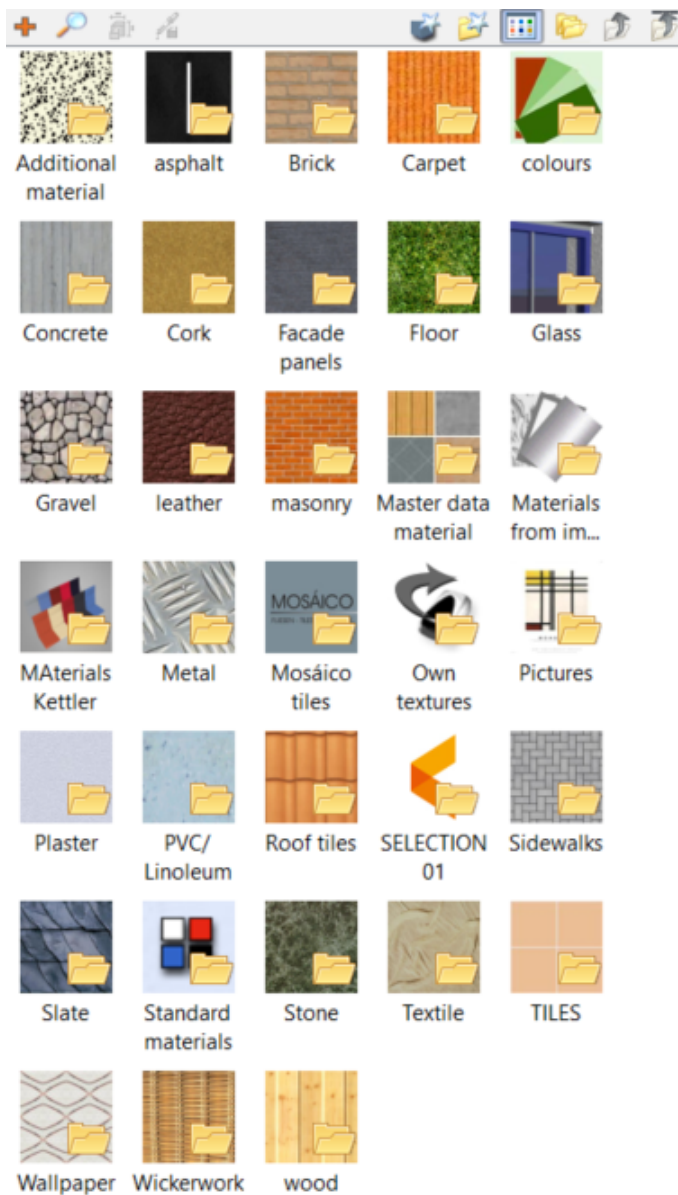



### Show folder structure as a tree

The folder structure can also be displayed as a tree. To do this, click on the button  **Show folder** in the Explorer. The structure is displayed in the upper area.

### Change folder

Double-click on the desired folder in the content area or click on the folder in the folder structure. The folder is opened and the contents are displayed.

Use the button  **Move up one folder** to switch back to the parent folder. The button  **Go to top folder** takes you back to the top of the structure.

### 13.10.2.1 The content area

#### Create new folder

Click on the button  **Create new folder**.

A dialog appears, please enter the name and select a suitable preview image. The new folder is created within the current folder.

#### Edit folder

Click on the folder in the content area and press the right mouse button. Select **Edit** in the context menu. You can change the name and change the preview image.

#### Delete folder

Click on the folder in the content area and press the right mouse button. Select **Delete** in the context menu. The folder and all the materials it contains are now deleted from the database.

#### Move folder

Click on the button  **Show folder** to display the folder structure as a tree. Click on the relevant folder and, holding down the left mouse button, drag it to the folder in the tree view in which the folder should be located.

#### Create new material

Click on the button  **Create new element**. The dialog with the material properties opens. Enter a material name in the **General properties** tab, enter the desired properties and close the dialog by clicking **OK**. The material is created in the current folder.

#### Deleting a material

Click on the material in the content area and press the right mouse button. Select **Delete** in the context menu. The material is now deleted from the database, but may remain in the scene.

#### Duplicate material

Select **Duplicate** in the context menu and the material is copied.

#### Edit material

Double-click on the material in the catalog and the dialog with the material properties opens. The properties are described in the **General properties** section below.

#### Move material

Click on the relevant material and, holding down the left mouse button, drag it to the folder in the tree view where the material should be located.

#### Databases

In Plan7Architect, materials are saved in databases. On startup, all databases with materials are loaded according to the current settings and displayed in the catalog. In the **Options|Select databases for saving** menu, you can specify in which database newly created materials are to be saved. By default, this is the **Own materials** database.

If you change a material, the material is changed in the database in which the material was originally saved; this can, but does not necessarily have to be the writable database.

#### Other folders - Show external files in the catalog

You can access this option by right-clicking in an empty area of the catalog and selecting **More folders** from the context menu. A dialog for selecting a directory opens. Select the desired directory and confirm your selection with **OK**. All image files in this directory and its subdirectories are read and integrated into the material catalog as a structure.

After a restart, the directory is displayed in your catalog and remains logged in for all further processing. Each folder integrated in this way is always displayed at the top level of the structure. Several directories can also be integrated into the catalog if required.

To remove the folder from the catalog again, right-click on an empty area of the catalog and deselect the folder in the context menu. A message appears stating that the change will only be visible after restarting Plan7Architect.

## 13.10.3 Use materials

### 13.10.3.1 Tap - Transfer



The pipette can be used to pick up material from the scene. Click on the area containing the material to be transferred. The **Transfer** function is now automatically activated. Click in turn on the areas that are to receive the selected material. **[Esc]** ends this process.

#### 13.10.3.1.1 Assign material

Hold down the left mouse button and drag the material onto the corresponding area. The material is now transferred.

Transferring material to walls supports additional functions:

- If you drag the material from the Explorer onto a wall (a wall segment), all connected wall segments of an outline (such as a room) are changed, provided they had the same material.
- If you drag the material from the Explorer onto a wall (a wall segment) while holding down the **[Shift]** key, only one segment will be given the new material.
- If you drag the material from the Explorer onto a wall (a wall segment) while holding down the **[Ctrl]+ [Shift]** key, all segments of the contiguous contour are provided with the new material, regardless of their original material.

### 13.10.3.2 Search

Click on the magnifying glass symbol in the Explorer



to open a search mask:



Now you can search for:

**names**

**Keywords**

**Whole word**

### 13.10.3.3 Edit

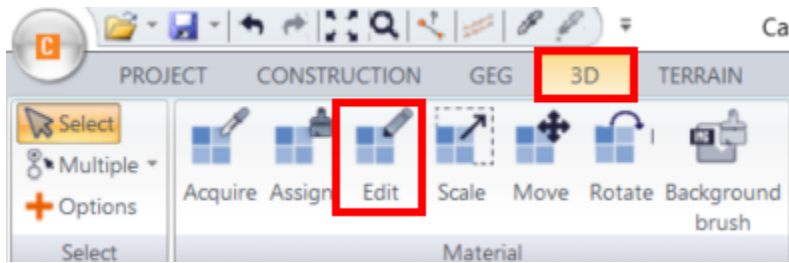

This function opens the dialog for the material settings.

Only the material of the selected area is changed, all others remain the same. Further information on the settings for materials can be found in the following section of this chapter.

### 13.10.3.4 Scale - Move - Rotate

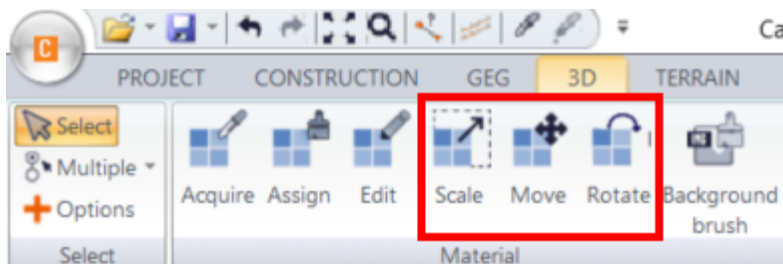

These three functions are used to edit the materials directly in the scene.

Select the function, click on the material to be edited and hold down the left mouse button. When scaling, the texture is displayed larger if you now move the mouse upwards. When rotating, the angle of rotation is increased when you move the mouse upwards. Only the selected material of the surface is edited, all other materials remain unchanged.

### 13.10.3.5 Shadow brush

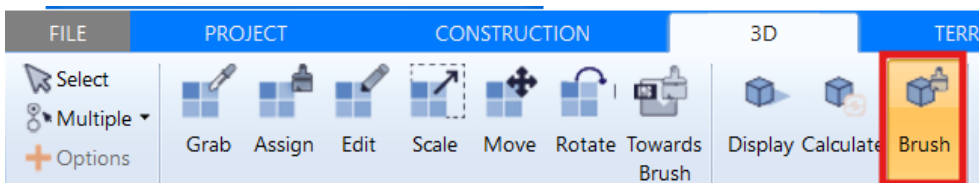

Activate the **Shadow brush** command and click on a surface of a 3D object. This surface can now also display shadows.

The shadow on a 3D object is calculated according to the surface that was clicked with the shadow brush when it was assigned.

### 13.10.3.6 Background brush

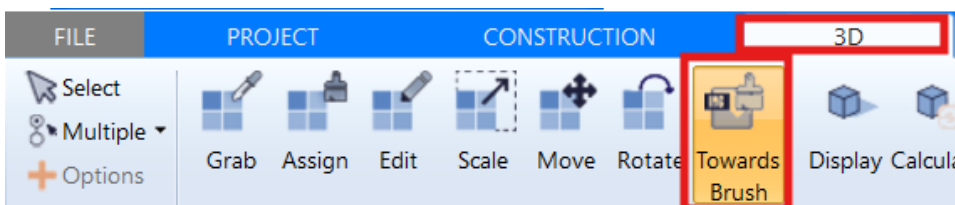

Use the **towards brush**  to transfer the appropriate section of the **background image**  as a material to the selected area. The background image is used as a texture in the material.

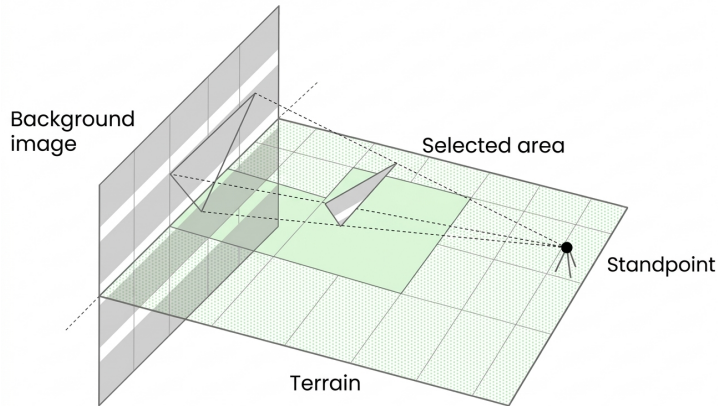

The limits for the material of the surface are calculated from the current viewpoint of the 3D model from the background image and transferred to the surface accordingly. The choice of viewpoint and the perspective parameters therefore influence the result. Areas of the background image that are obscured by the terrain are also taken into account.

In the next illustration, the background image is mapped onto the terrain. You can see the perspective distortion of the image on the surface. From the viewpoint, however, the new material looks exactly like the hidden area of the background image. Although the bars of the background image are originally the same height, they are displayed at different heights on the terrain. This is due to the fact that the distance to the individual bars is taken into account when viewing from the viewpoint. A bar that is further away must now be displayed wider in order to appear the same height.

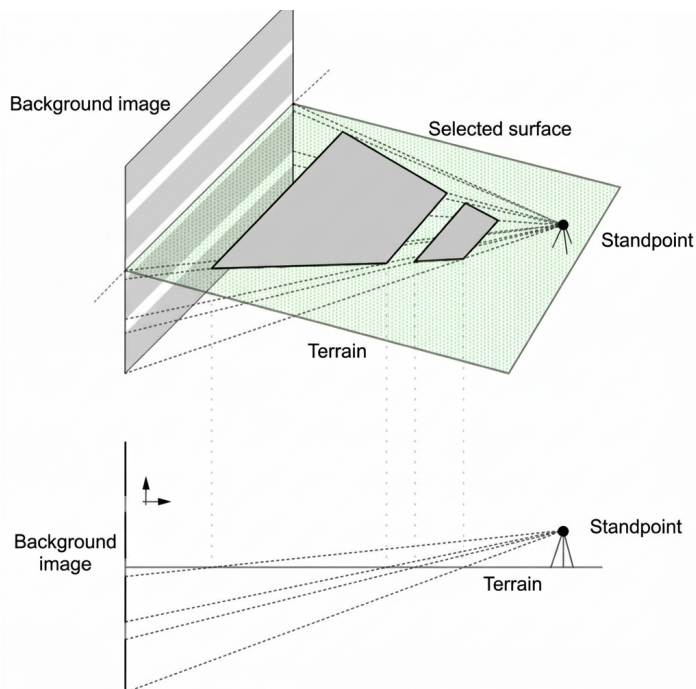

### 13.10.4 General settings

In this tab of the **Material settings** dialog (opened with Edit), you can specify whether the material uses a texture map, a bump map or a reflection map.

If one of the three options is activated, a tab for the settings of this texture is also displayed.

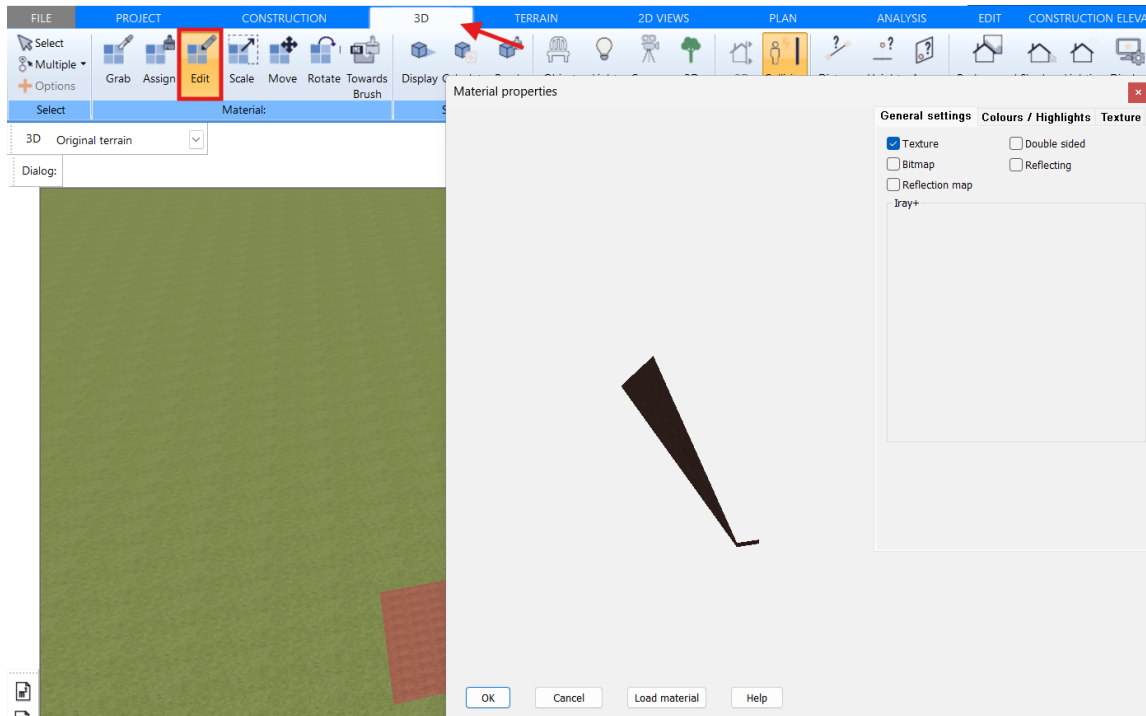

You can also set whether the material is shown **on both sides**. A surface can normally only be viewed from one side in the 3D window. The surfaces of the 3D representation of a wall are displayed correctly from a point of view outside the wall. The invisible, rear surfaces are not displayed. The advantage of surfaces that are only visible on one side is the considerably faster 3D display, but in special cases it may be necessary for the surface to be visible from both sides. This is achieved with the **double-sided** option.

If the **Mirroring** option is activated, the Mirroring tab is displayed.

### 13.10.4.1 Select material

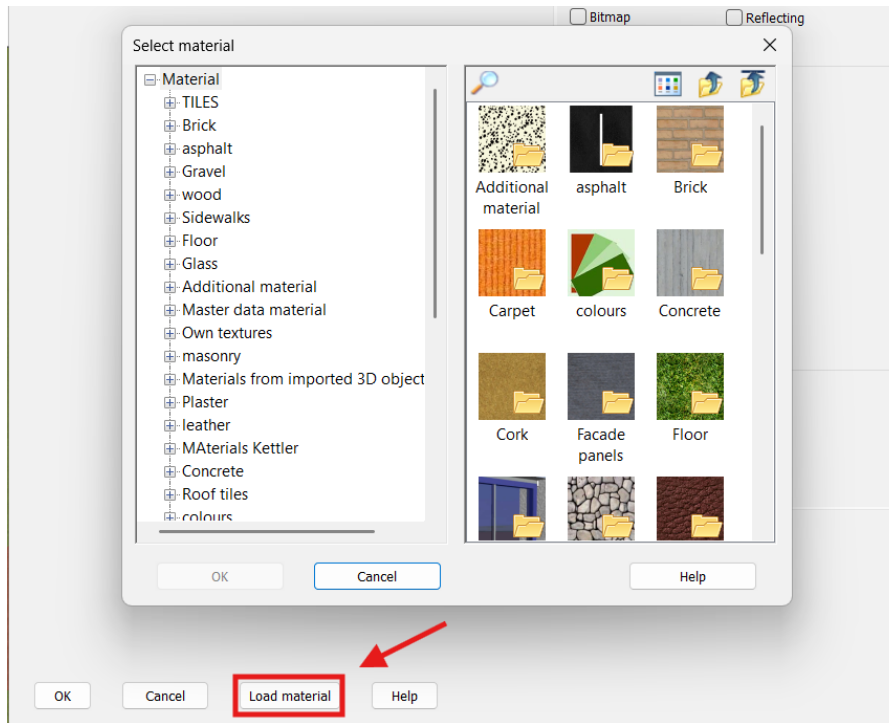

Select the desired material in the tree structure on the left, a preview view appears in the right window, a material preview image, e.g. different plaster categories as in this example.

### 13.10.4.2 Colors/glow lights

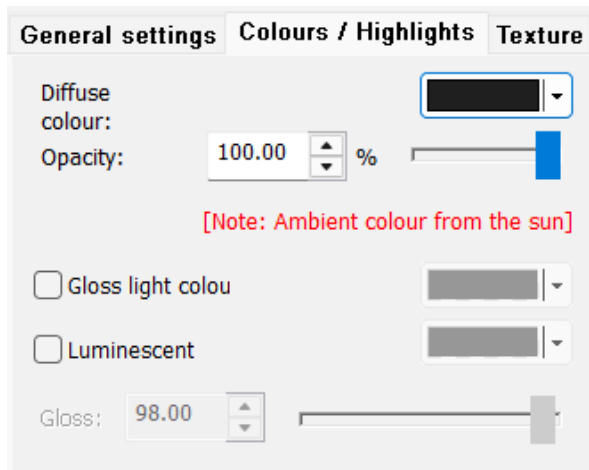

The light components and the **opacity** (transparency) of the material are set in this tab. The description of the effect of the light components can be found in the introduction to the **Light/light components** chapter. However, it is important to note that the diffuse component has no influence on the material when using textures, as the diffuse component is completely described by the texture.

### 13.10.4.3 Reflection

In contrast to the reflection maps, the reflection shows the actual reflection of the scene and not just a texture. The computational effort required to display reflections is very high, so the following should be taken into account:

- While working, the display of reflections can be suppressed to speed things up (menu **View|Display quality|with reflections**).

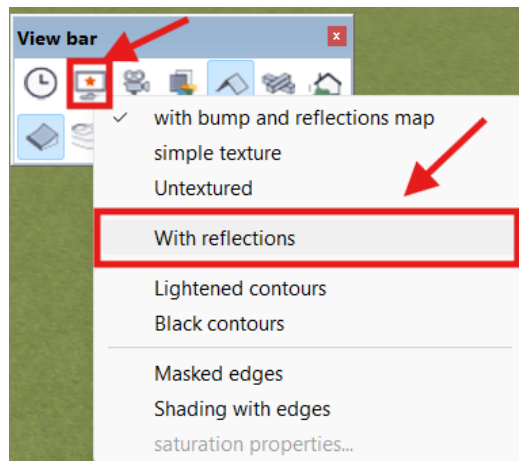

- Only use reflections for those surfaces that are important for the quality of the visualization. Small surfaces in particular (chair legs, window frames) can normally be displayed better with reflection maps than with real reflections.
- Surfaces that lie in one plane require less computational effort. Displaying all floors of several rooms on one floor as reflections is faster than displaying the floors of a few rooms on different floors.

Mirroring cannot be used on surfaces that are displayed transparently.

The reflective proportion of the material can be set in the **Reflection** tab.

A value of 5 % is suitable for a tiled floor, 100 % would be the perfectly reflective surface.

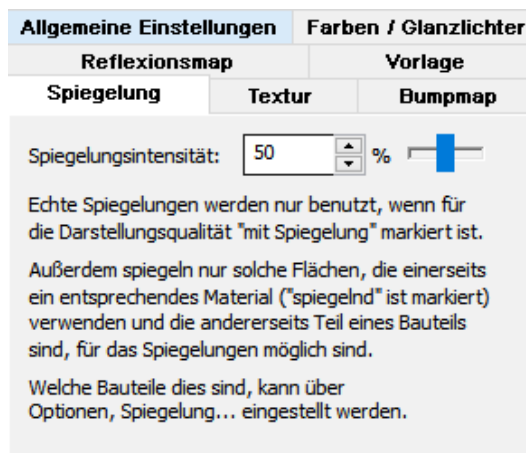

In the **View|Mirroring** menu, you can set which surfaces are reflective.

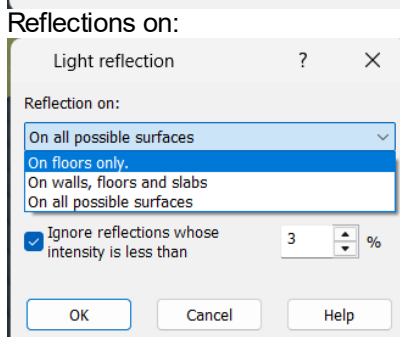
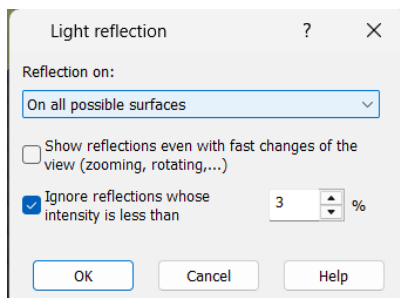
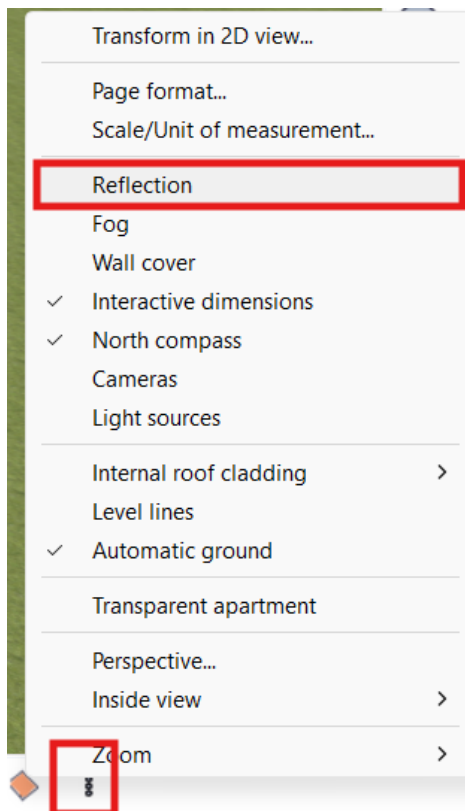

In general, this selection can remain set **for all possible surfaces** if you make sure during editing that you only apply material with a reflective effect to those surfaces that are actually displayed as reflective.

#### 13.10.4.4 Texture

##### Mix with color

Normally, a texture replaces the diffuse color of the object.

The diffuse light component of the material has no influence when using a texture. However, if the Mix with **color** option is activated, the texture is applied together with the diffuse color. This option is helpful when using gray value textures, which determine the brightness of the material. The hue comes from the value of the diffuse color.

### Is mask texture

If you select this option, the object is only displayed in places where the texture used is not exactly black (color component 0,0,0).

You can therefore use textures to "punch out" areas from an object.

### Texture filter

Textures are filtered when displayed on the screen and are therefore slightly blurred, but the filtered display is very suitable for conventional textures, unless checkerboard-like patterns are shown. In this case, the checkerboard effect could be lost due to the filtering.

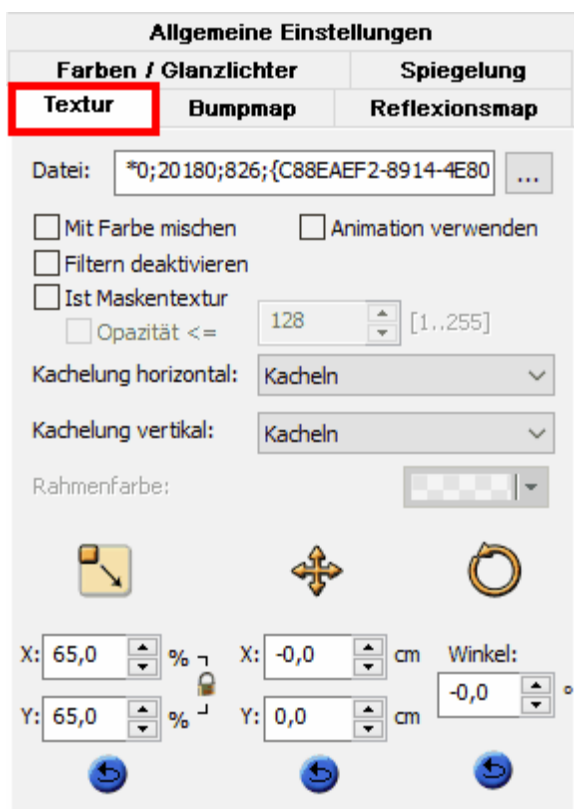

### The Texture dialog

The settings for horizontal and vertical tiling determine the way in which the texture is applied to the surface.

There are four options

1. **Tile** repeats the texture up to the boundaries of the surface
2. **Mirrored repeat** up to the limits of the surface
3. **Extend texture**: the texture is only shown once, the edge area of the texture is extended to the boundaries of the surface
4. **Frame around texture**: the texture is only shown once, the border area is filled with the definable frame color. This color can also be transparent.

The texture can be adjusted in size, position and angle. This is done either via buttons in Construction mode (described in the *Use material* section in this chapter) or via the settings in this dialog. The difference is that the settings in this dialog can be entered numerically.

### 13.10.4.5 Reflection map

If you select **Reflection map** in the **General** tab, an additional tab is displayed for the properties of the reflection map. Reflection maps are also textures, but are seen as a "mirror image". Depending on where you look at an object with this material, you will see different parts of the reflection map. This method of using textures is used to simulate ideal reflections, although it is not the object's surroundings that are reflected in the object, but the texture.

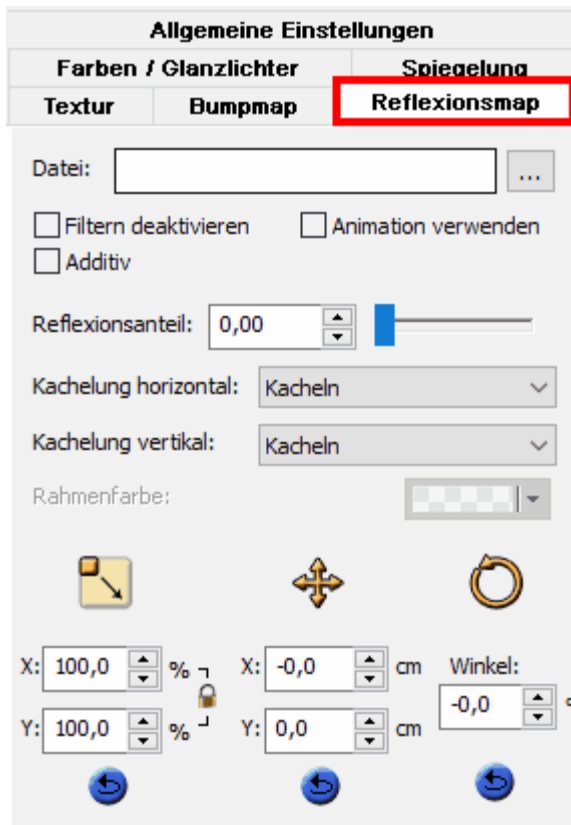

If the **Additive** option is activated, the intensity of the reflection is added to the conventional texture.

The reflection percentage from 0 to 100% determines the proportion of the reflection compared to the texture. A value of 10% provides a slight reflection, 70% a strong reflection.

The other properties are analogous to the properties of textures.

### 13.10.4.6 Bumpmap

Bump maps are used to simulate structured or rough surfaces. In order to remain compatible with older graphics cards, the quality of the display has to make some compromises.

It is assumed that reflection maps are used. The generated relief is only displayed in the reflective part. Non-reflective surfaces are better displayed with conventional textures without bumpmaps.

Bump maps also use image files as a basis. The brightness is decisive for the height of the generated structure. Dark areas are displayed lower, light areas higher. The texture assigned to the material can also be used as a bump map via the **Like texture** property. However, the result is often better if *black/white textures* specially created for bump maps are used.

The strength of the effect can be varied using the **Bump Map depth** value.

The other properties of bumpmaps are analogous to normal textures.

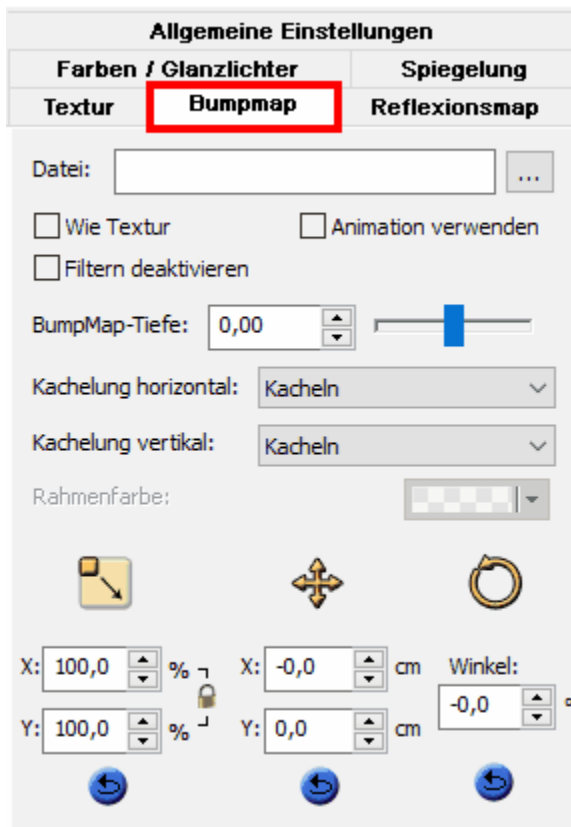

## 13.11 Video

The aim of the video function in Plan7Architect is to create video sequences of the building model quickly and easily without time-consuming input.

Open the bar with the video functions via the **Video** button.

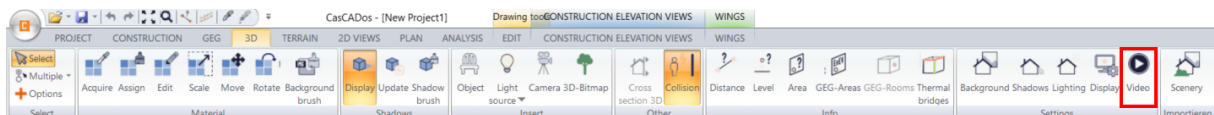

The video function in Plan7Architect works according to the following principle:

An animation is created in the project. This animation is the tour in or around the model.

### The five steps to a building animation:

1. preparing the model and optionally defining the required sections
2. recording the animation
3. if necessary, change to the highest display quality

4. shadow calculation
5. save AVI file

Animation:

- Is only the tour in the project itself, a change to the building has no influence on the animation
- Is saved in the project file
- Any number of animations can be saved in one file

Video:

- Is the result of the output of an animation as an AVI file



### Step by step

Tip: Use a simple model for the first exercises to avoid long waiting times.

### We create a video with a circular flight

- Position your viewing point at the desired start position. The target point is also important. The target point can be changed by zooming to the desired position (using the scroll wheel).
- Check the target point by rotating the model (with the scroll wheel held down)
- Save the position as a section ( *View|Section|Newmenu* )



- Create a new animation by clicking on **the selection list new animation**. Enter a name.
- Now press the record button  , from now on all movements of the position or target point will be recorded.
- Now click on the button **Rotation** 

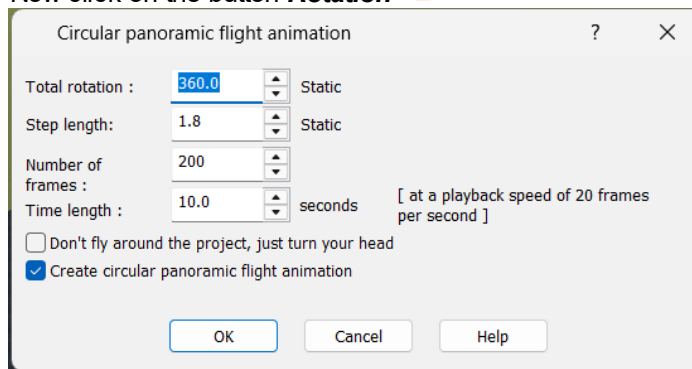

- Select 360° as the total rotation (from the viewer's point of view)
- Select 20 seconds as the duration (alternatively, you could also enter the increment or the number of images here)
- Select the two other options as shown in the graphic above and
- Confirm the entries with **OK**.
- You have now entered a sightseeing flight in the animation.

Animation  <no animation>

Use this button to manage the existing animations in the project.

You can create a new animation, eject the current animation from the recorder (like a video tape) or delete the current animation.

During recording, you can move by pressing the [LEFT ARROW], [RIGHT ARROW], [UP ARROW], [DOWN ARROW] buttons + moving the mouse. The mouse pointer shows the direction to the target point. The [PICTURE UP] and [PICTURE DOWN] keys move the viewpoint up and down. The [SHIFT] + [ARROW LEFT] and [SHIFT] + [ARROW RIGHT] keys move the viewpoint sideways.

If required, you can **load** a new camera using the function in the **Setup|Camera** menu.

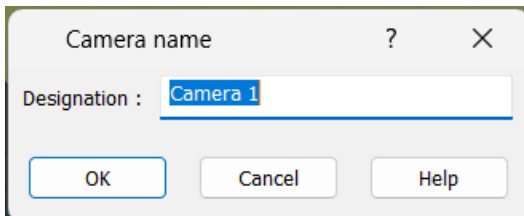
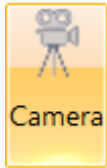

### Recorder buttons



These buttons are only active when an animation is activated (loaded). They work in a similar way to the control buttons on a video recorder. The red button starts and stops the recording process.

### Frames per second (FPS)



Frames per second, a measure of the frame rate

The frame rate refers to the number of individual images that are recorded in a certain period of time. A sufficiently high frame rate enables the viewer to view a sequence of individual images as a continuous image sequence.

The abbreviation fps (frames per second) refers to the number of images per second.

The human eye processes consecutive images as a moving scene from around 16 to 18 frames per second; Plan7Architect uses 20 frames per second as the standard value.

### Still images



This function is only available during recording (REC button pressed).

With this function, still images can be inserted into the animation at any time and the virtual tracking shot can be interrupted for the specified time in seconds.

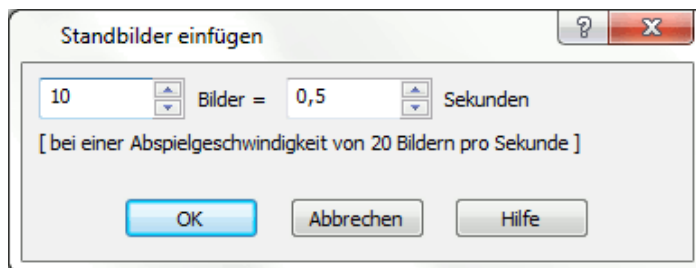

### Sightseeing flight



This function is only available during recording (REC button pressed).

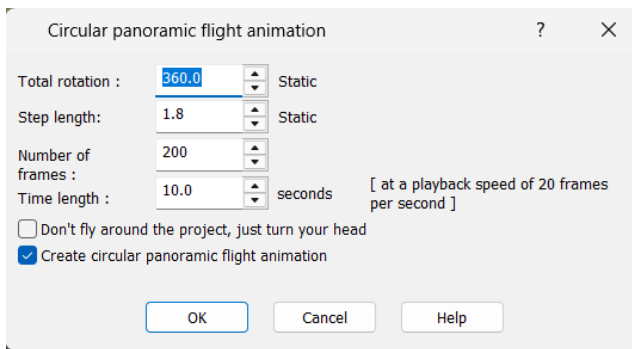

The sight seeing flight always starts at the current viewer position. The longer the video is to last, the more images and the smaller the set increment (angle between two images).

### Flying to a defined section

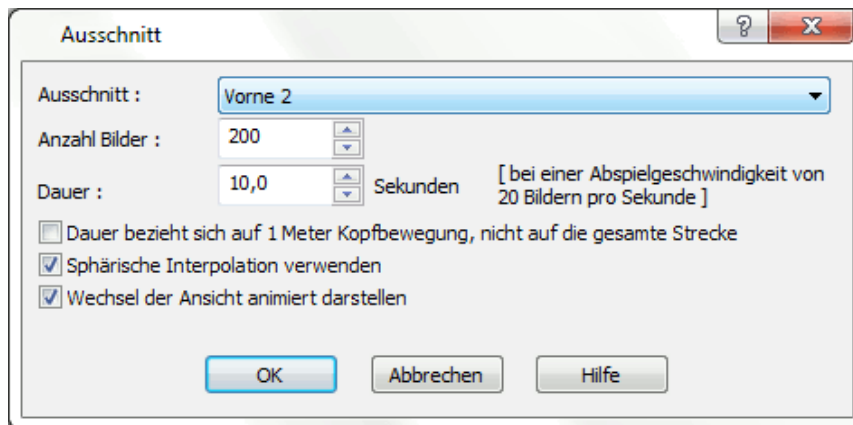

Save some interesting sections in your project in 3D mode. When creating the animation, you can use this function to fly from one section to the next. The movement between the two sections is linear. The time (or the number of frames) can be set in the advanced settings. Another interesting possibility is the option to relate the set parameters to a meter of head movement. This allows you to achieve a continuous speed even between sections that are at different distances from each other.

### Saving as an avi file

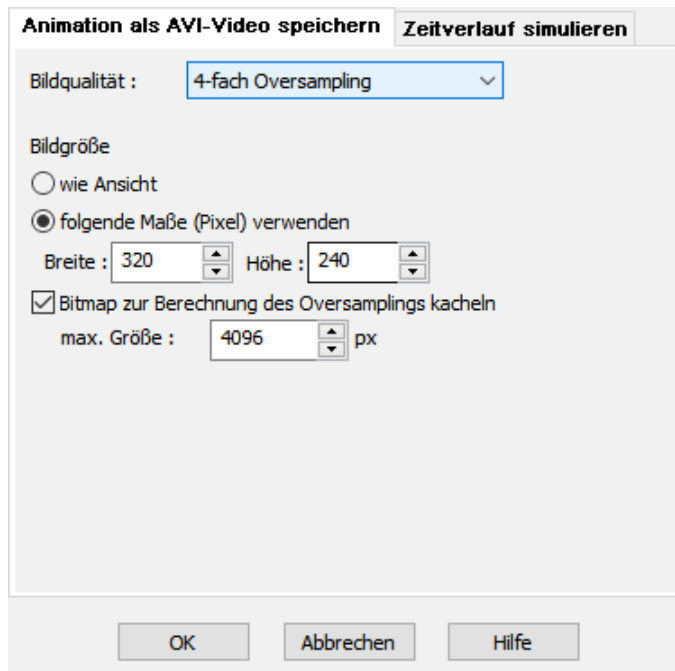
**Image quality:**

- without oversampling
- 4x oversampling
- 9x oversampling
- 16x oversampling

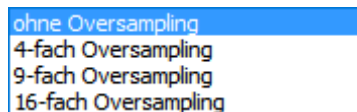

Oversampling blurs color gradients and transitions at edges. These are not jagged, the advantage for videos is that edges do not flicker, making the whole video appear smoother.

Note: The computing time is considerably higher and it is no longer possible to save such high resolutions. It is therefore recommended to use 4x or maximum 9x oversampling.

The technical background to oversampling is as follows: With 4x oversampling (2x2), 2 pixels next to each other and 2 pixels below each other are mixed into one pixel. This reduces the image width and height by half. For the same image size, the computing time increases fourfold.

Since Plan7Architect can calculate internally with 8192 x 8192 pixels, the maximum setting for 4-fold oversampling 4096 x 4096  
9-fold oversampling 2730 x 2730 and  
16-fold oversampling 2048 x 2048 pixels.

Note: If a higher number of pixels is set, Plan7Architect saves the image with the above-mentioned number.

**Image size**

- like view
- Use user-defined dimensions (pixels)

Tile bitmap to calculate the oversampling

max. size in px

### **Simulate time coursetab :**

Here you have the option of simulating the animation for a period of 24 hours, for example.

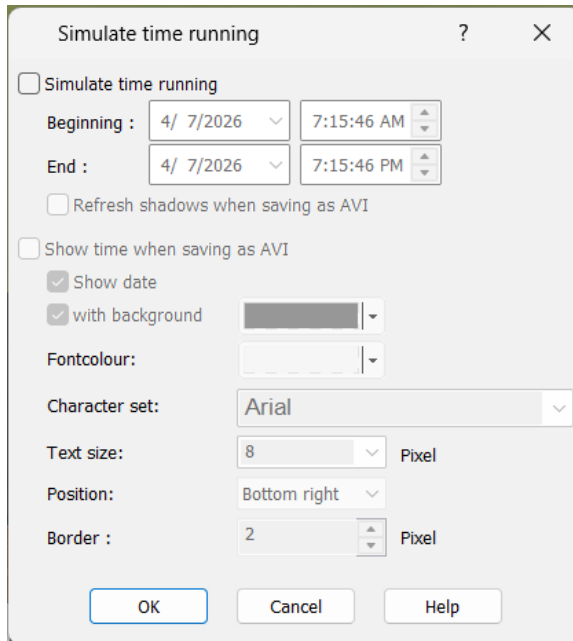

After confirming with **OK**, the name for the .avi file is entered.

## **13.12 3D Player Internet object**

The 3D Player can be used to present a project to the customer without Plan7Architect. The project can be exported in the 3D view

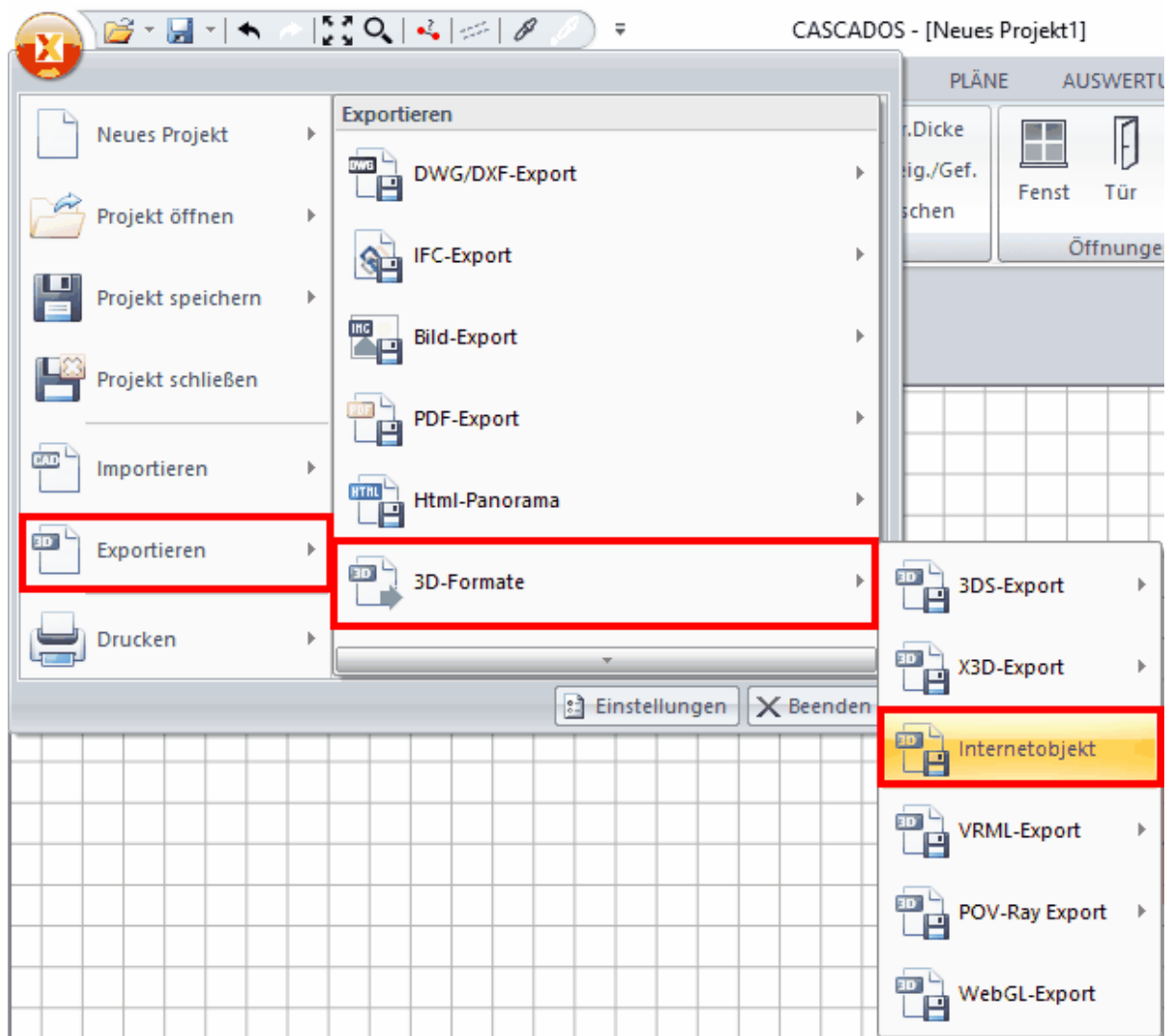

2 files are written

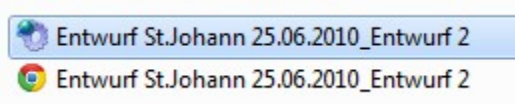

and when the first file is opened, the external player is started at the same time

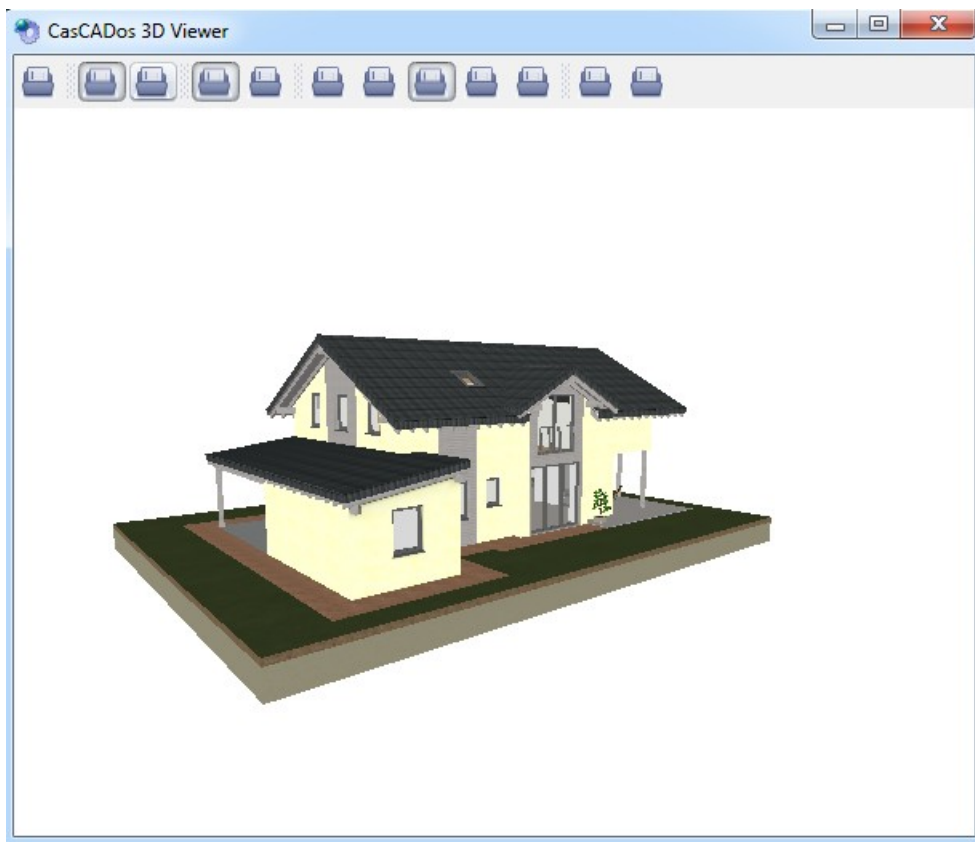

In this player, the project can be rotated, shadows can be calculated, you can set 'Walk through' and other options

## 14 Terrain

### 14.1 General information

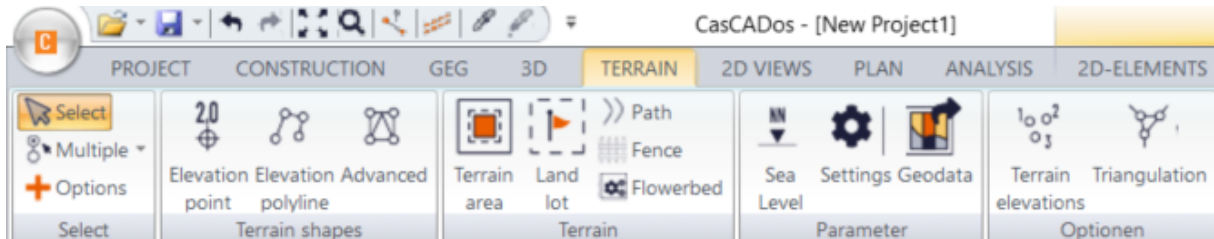

The terrain mode offers you all the functions you need to model a property and its immediate surroundings. In Plan7Architect, a distinction is made between different types of terrain: the landscape, the property and terrain areas. The terrain can be modeled with simple and extended terrain shapes.

3D surveyor data from a surveying office can also be imported.

### 14.2 Landscape

The **landscape** terrain type is created automatically in every Plan7Architect project.

The landscape is an "infinitely" large area, i.e. it always extends to the horizon in 3D mode. The height of the landscape is also changed by using terrain shapes.

Each terrain surface, including the landscape, is divided into so-called facets for the 3D display. These facets are necessary to model height differences in the terrain. The finer the faceting is selected, the more precisely the course of the terrain adapts to the terrain shapes used and the finer the rounding is displayed. However, fine faceting also requires more computing power.

However, a facet node is always created at the reference points of terrain shapes. This ensures that the height of the terrain at an elevation point, for example, exactly represents its elevation, regardless of the faceting selected.

If you click on the **landscape** in 3D mode, both the material and the faceting can be set in the properties dialogs.

The landscape is not displayed in the Construction and Terrain floor plan modes.

In the **View** menu of 3D mode, you can specify whether the landscape is visible or not.

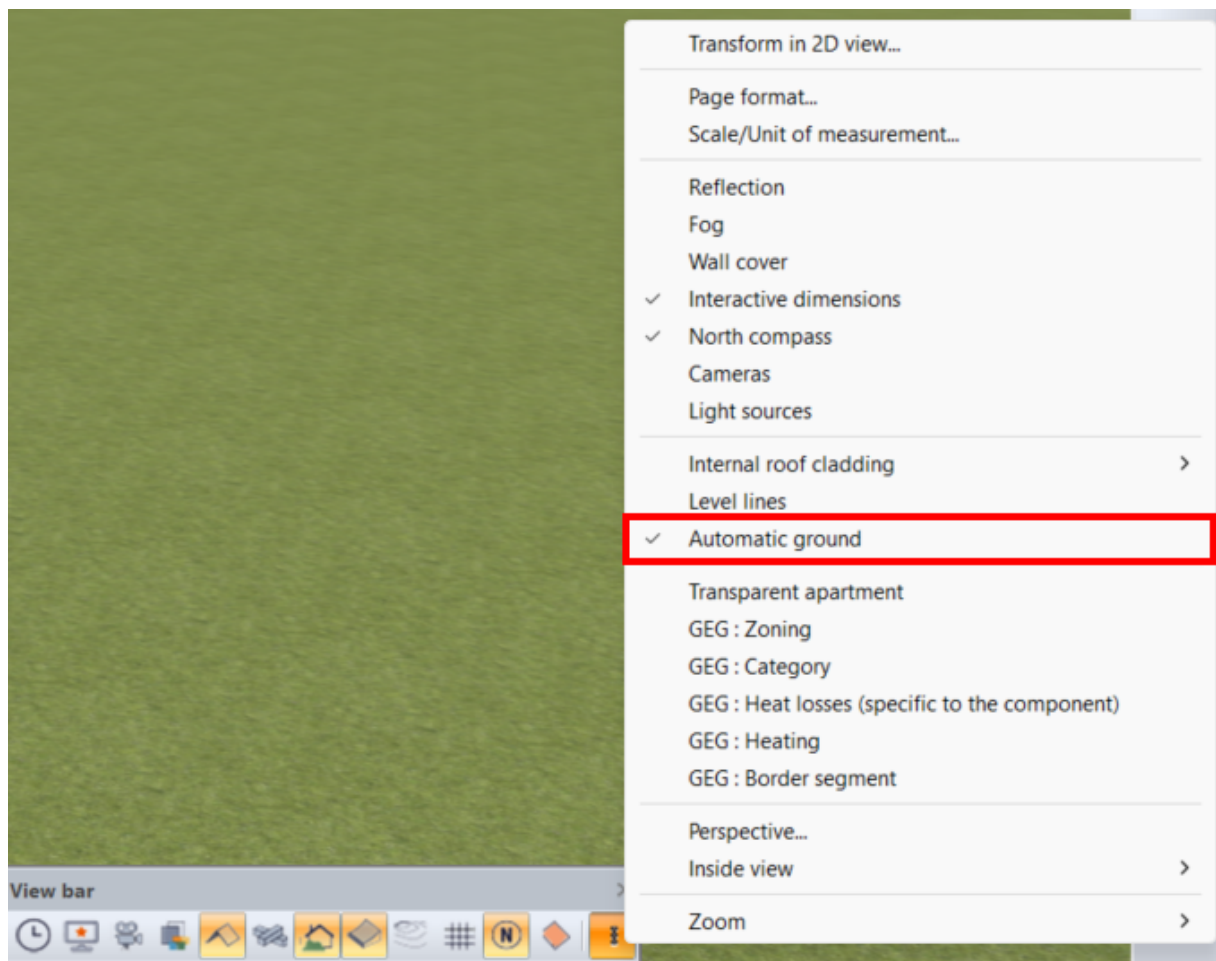

### 14.3 Range

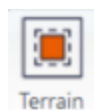

Terrain areas **area** are placed on the property or landscape, always following the elevation of the terrain. Terrain areas can be provided with a texture that differs from the terrain. They are therefore suitable for depicting driveways, forecourts, etc.

Terrain areas that are frequently used are stored in the catalogue. Further information on [catalogues](#)<sup>[150]</sup> can be found in the **General property dialogues** chapter.

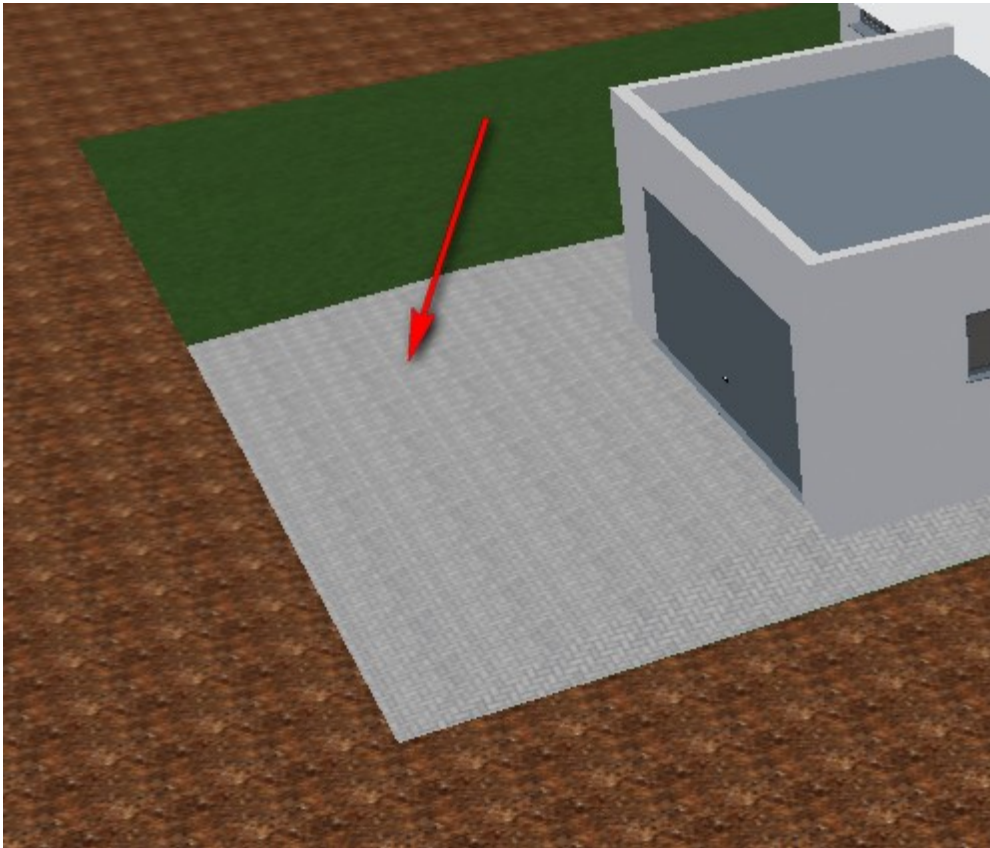

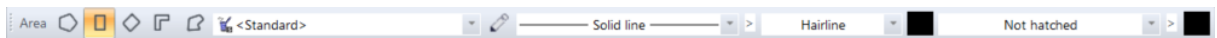

### 14.3.1 Draw area

The following options are available for drawing the property area:





#### Options:

Draw area (polygon) 

Draw area (rectangle) 

Draw area (rotated rectangle) 

Draw area (polygon with fixed width) 

Draw area (spline) 

### 14.3.2 Property dialogues

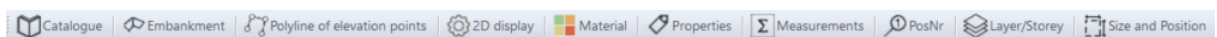

#### Slope

The [Slope](#)<sup>[454]</sup> properties dialogue is explained in the [Terrain](#)<sup>[450]</sup> chapter.

### Ridge

The [Elevation](#)<sup>[456]</sup> properties dialogue is explained in the Terrain [shapes](#)<sup>[455]</sup> chapter.

The properties dialog use [Catalogue](#)<sup>[349]</sup>, [Contour](#)<sup>[138]</sup>, [Fill](#)<sup>[140]</sup> and [Hatching](#)<sup>[141]</sup>, [Material](#)<sup>[430]</sup>, [Properties](#), [Masses](#), [position number](#)<sup>[147]</sup>, [Size and Item](#)<sup>[143]</sup> are explained in the [General properties dialogues](#)<sup>[134]</sup> chapter.

## 14.4 Property

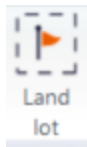

The property [Land lot](#) is drawn as a polygon on the landscape. A material that differs from the landscape can be assigned to the plot. If the landscape is not visible, the project can only be shown with the terrain area of the plot.

Plots that are frequently used are stored in the catalog. Further information on the [catalogs](#)<sup>[150]</sup> can be found in the [General property dialogs](#) chapter.

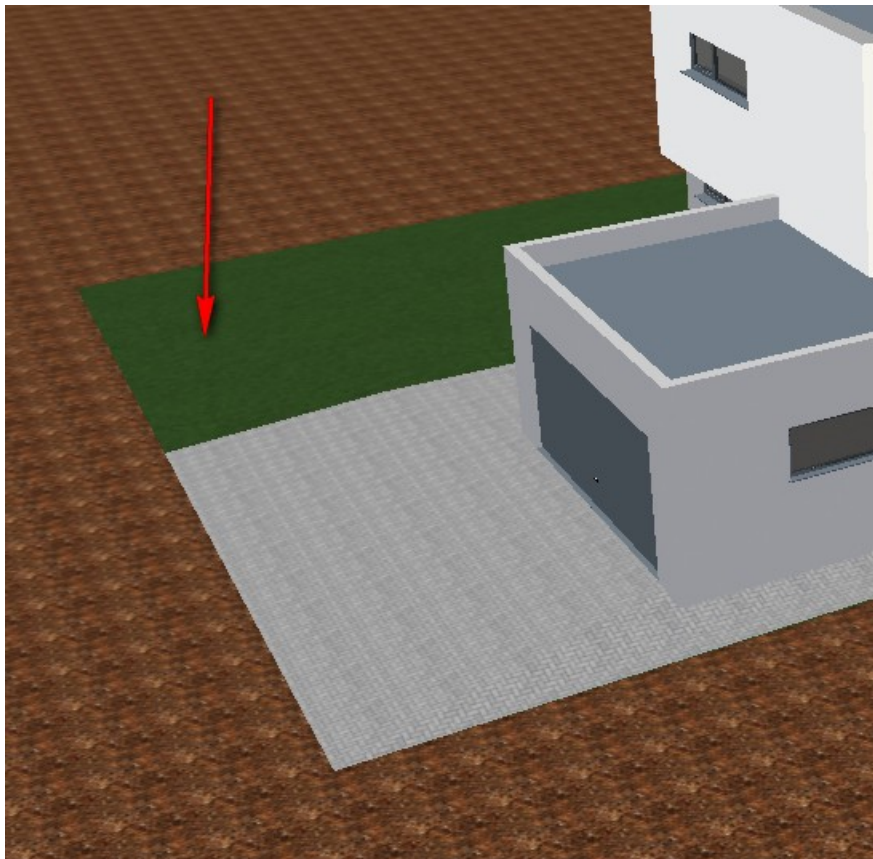

### 14.4.1 Draw property

The following options are available for drawing the property outline:

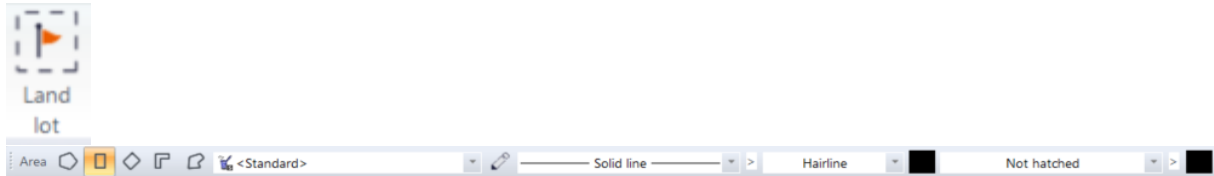

#### Options:

Plot (polygon) 

Plot (rectangle) 

Plot (rotated rectangle) 

Plot (polygon with fixed width) 

Plot (spline) 

### 14.4.2 Property dialogs

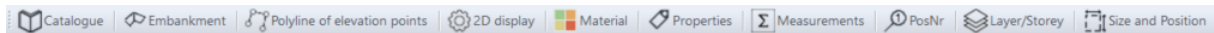

#### Embankment

The property can also be provided with a slope.

#### Elevation

The [Elevation](#)<sup>[456]</sup> properties dialog is explained in the [Terrain shapes](#)<sup>[455]</sup> chapter.

The [Catalog](#)<sup>[349]</sup>, [Contour](#)<sup>[138]</sup>, [Fill](#)<sup>[140]</sup> and [Hatching](#)<sup>[141]</sup>, [Material](#)<sup>[430]</sup>, [Properties](#), [Masses](#), [position number](#)<sup>[147]</sup>, [Size and position](#)<sup>[143]</sup> properties dialogs are explained in the [General properties dialogs](#)<sup>[134]</sup> chapter.

#### 14.4.2.1 Embankment

Each plot can be provided with a slope. Click on the **Embankment** button in the properties dialog to open the menu:

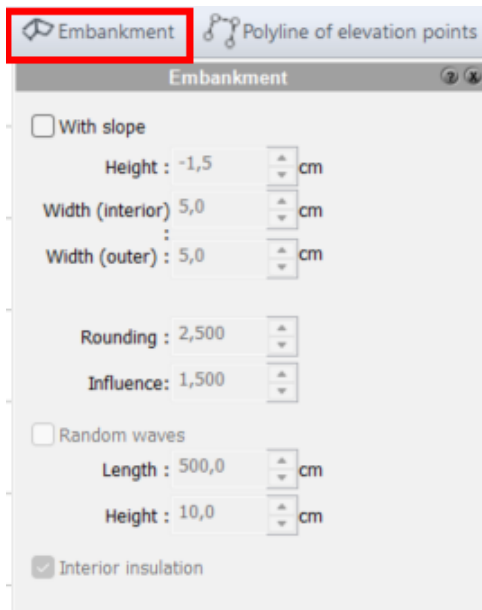
**Options menu:**

With slope

Height cm

Width (inside) cm

Width (outside) cm

Rounding

Influence

With random waves

Length cm

Height cm

Shield the inside

## 14.5 Terrain shapes

### 14.5.1 Simple terrain shapes

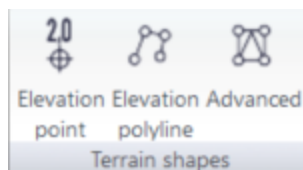

Then select the input type.

### 14.5.1.1 High point

Select the **elevation point** input type

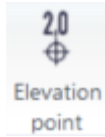

Height points change the height of the terrain at a point. If you place a height point in the planning, the height of the terrain at this point is suggested. Enter the corresponding value.

The values for rounding and influence regulate the type of adjustment of the surrounding terrain at this elevation point. The greater the rounding, the steeper the surrounding terrain rises or falls. The influence determines the extent to which the height of the point influences the surrounding terrain.

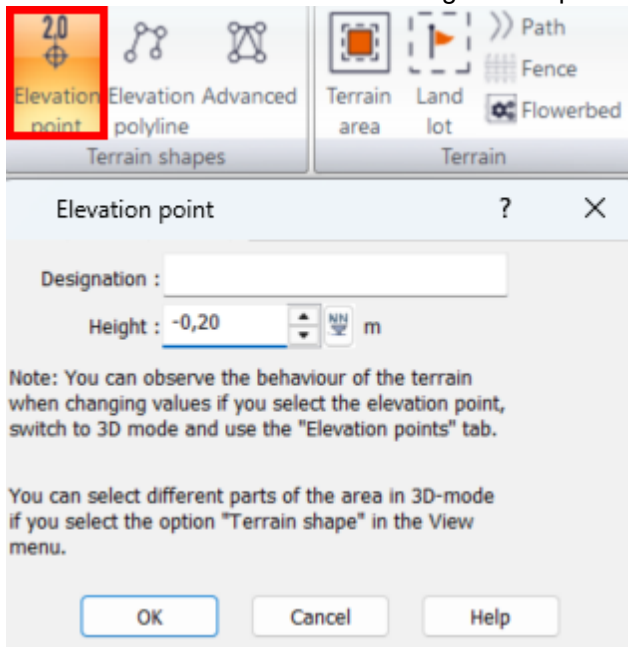

### 14.5.1.2 Ridge

Select the input type **contour** line

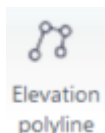

A contour is entered as a polygon with any number of elevation points. End the entry with **[Esc]**.

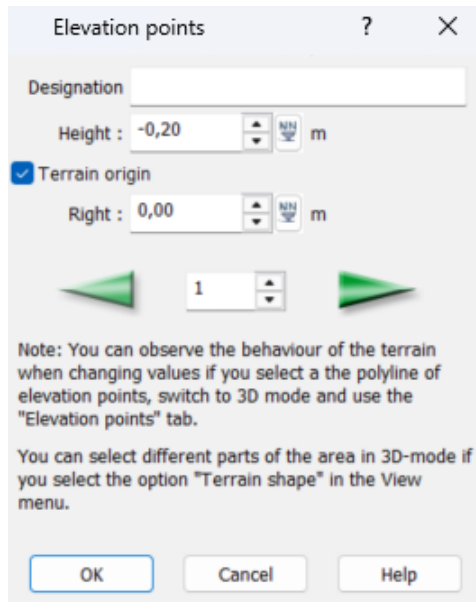

A contour course can also be entered as a closed polygon. Please note that for contour lines with constant heights, the value can be set as a global setting, meaning that the height entry for all individual points can be omitted.

The values for rounding and influence apply analogously to the height point.

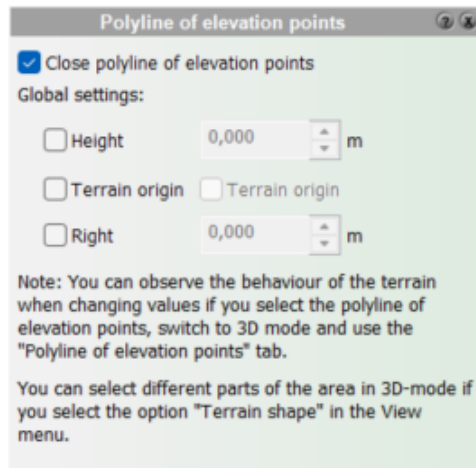

## 14.5.2 Extended terrain shapes

Click on the **Advanced terrain shape** button in **Terrain** mode.

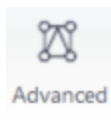

### 14.5.2.1 Overview of terrain shapes

Each terrain shape is shown in plan view and in 3D mode. In 3D mode, the terrain shapes can also be displayed without the yellow markings (menu bar **View**|**Terrain shapes**).

#### Ramp

creates a sloping flat rectangle in the terrain

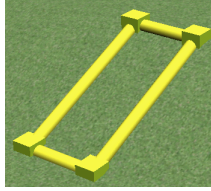
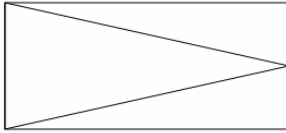

### Hill

The minimum value of the terrain shape applies to the outer rectangle, the maximum value applies to the center. It is certainly necessary to vary the influence and rounding factor in order to achieve appealing shapes.

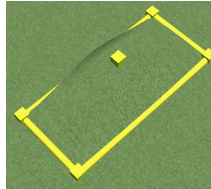
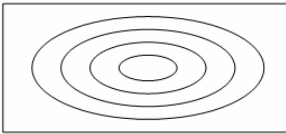

### Plateau

The plateau creates an inner flat rectangle on the maximum, the outer rectangle lies on the minimum of the terrain shape.

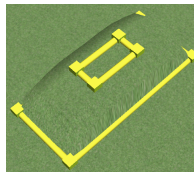

### Edge

Two rectangles are displayed. One is at the maximum, the other at the minimum value of the terrain shape. The course of the edge can be changed by rotating or mirroring the terrain shape.

#### 14.5.2.2 Properties dialog Terrain shape

The terrain shape is selected in the first selection list. An overview of the individual terrain shapes can be found in the previous chapter.

The minimum and maximum values are recorded in relation to the absolute height.

Each terrain shape consists of several elevation points. These height points also influence the surrounding terrain.

The height profile can be mirrored or rotated using the corresponding options.

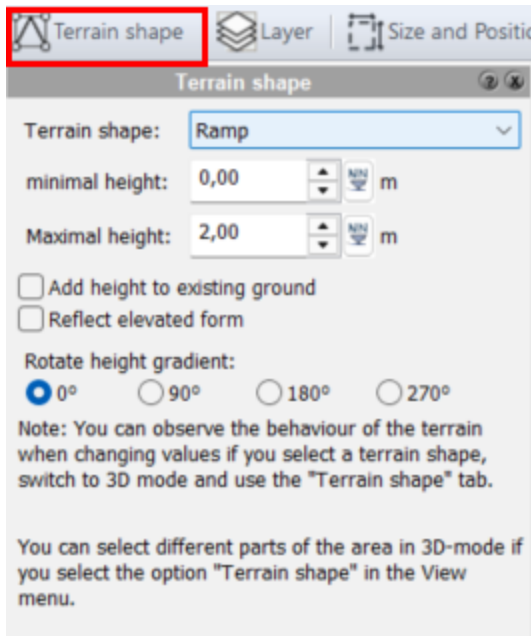

### 14.5.2.3 Drawing extended terrain shapes

First select the desired input type. Then specify the type of terrain shape in the Terrain shape properties dialog.



The input types for extended terrain shapes:

- **Terrain shape 4 points**  
 Required input: 4 points  
 The railing shape is entered using any four corner points.
- **Rectangle terrain shape**  
 Required input: 2 points  
 The terrain shape is entered using two diagonally opposite corner points.
- **Terrain shape rotated rectangle**  
 Required input: 3 points  
 First define one side of the rectangle with two points. The height of the rectangle is defined with the third point.

## 14.6 Paths

Click on the **Paths** button  in **Terrain** mode.

A path is placed as a polygonal area on the terrain; the path follows the elevation of the terrain. A path is entered as a single section, polygon or spline; the path width is variable.



### 14.6.1 Draw paths

Paths are always stored on the **Terrain** layer. However, this assignment can be changed later. Select the desired input type before drawing the path.

 possible input options:

**Offset** - the path is constructed parallel to the input points with offset.

#### Input types

- **Path (line)**   
Required input: 2 points  
The path is entered via two end points.
- **Polygon**   
Required input: n points  
The path is entered via any number of corner points.
- **Spline**   
Required input: n points  
The path is drawn as a spline with any number of points.

## 14.6.2 Property dialogs

### **Path**

Define the width of the path here.



### **Slope**

Here you can optionally define the properties for the slope of the path.

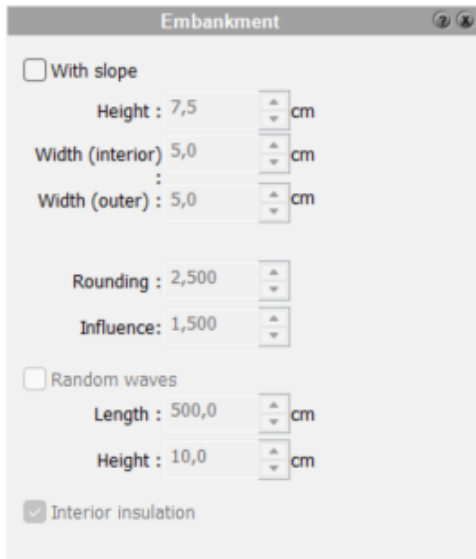

### **Catalog**

Component templates are offered in the catalog. If you select a component template, all parameters of the path are adjusted. You can find more information on [catalogs](#)<sup>[150]</sup> in the **General properties dialogs** chapter.

Further information on the properties [Layer](#)<sup>[143]</sup>, [Size/Position](#)<sup>[143]</sup>, [Contour](#)<sup>[138]</sup>, [Fill](#)<sup>[140]</sup> and [Hatching](#)<sup>[141]</sup> can be found in the General **properties dialogs** chapter.

## 14.7 Beete

Click on the **Beds** button  in **Terrain** mode.

Beds are used to add planting objects to selected areas.

Beds are always placed on the **Terrain** layer. However, this assignment can be changed later. Select the desired input type.

### 14.7.1 Input types

 Possible input options:

**Automatic contour recognition for terrain areas** 

Required input: 1 point

The contour of the bed is automatically determined within a drawn terrain area.

The *Show objects during input* option has no effect with this input type.

- **Polygon** 

Required input: n points  
The bed is entered using any number of corner points. End the function with **[Esc]**
- **Polygon with fixed width** 

Required input: n points  
The bed is entered using any number of corner points. A "band" of the set width with a closed contour is created.
- **Rectangle** 

Required input: 2 points  
The bed is entered using two diagonally opposite corner points.
- **Rotated rectangle** 

Required input: 3 points  
First define one side of the rectangle with two points. The height of the rectangle is defined with the third point.
- **Spline** 

Required input: n points  
The bed is drawn as a spline with any number of corner points.

## 14.7.2 Property dialogs

### Catalog

Component templates are offered in the catalog. If you select a component template, all parameters of the bed are adjusted.

You can find further information on [catalogs](#)<sup>[150]</sup> in the General properties [dialogs](#)<sup>[134]</sup> chapter.

Further information on the properties [Layer](#)<sup>[145]</sup> and [Size/Position](#)<sup>[145]</sup> can be found in the General [properties](#)<sup>[134]</sup> dialogs chapter.

### 14.7.2.1 Planting objects

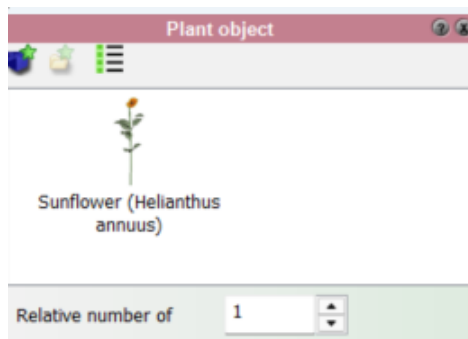

The planting object(s) is/are defined in this dialog. Click on the **Add plant object** button to open the dialog for selecting the object from the 3D object catalogs. An object can also be loaded from a file in this dialog if necessary.

If several objects are added, the number can be specified for each element. As an alternative to a total number of all objects in the bed, a number can be specified for each object. The setting for using the so-called relative species count can be found in the **Placement** dialog.

### 14.7.2.2 Fitting

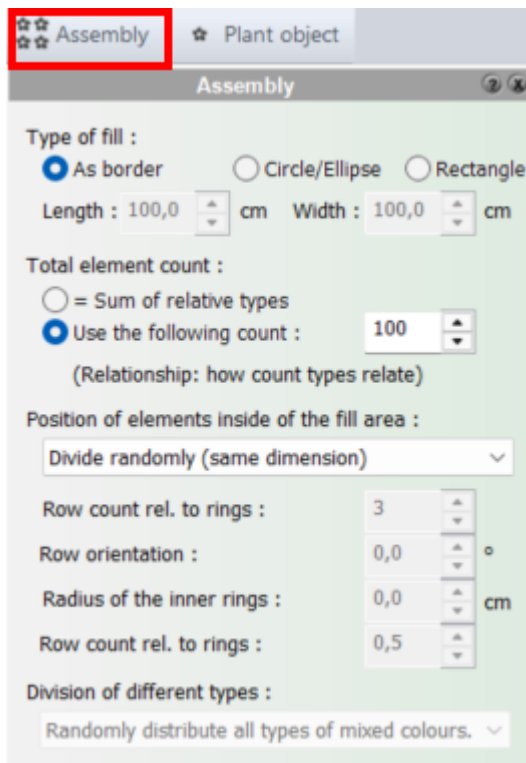

The **shape** of the bed can be represented as follows:

- **like border**  
corresponds to the shape of the contour entered
- **Circle/ellipse**  
The largest possible circle/ellipse within the contour is determined.
- **Rectangle**  
the largest possible rectangle within the contour entered

The **total number** of elements is defined as the sum of the relative number of types or as a fixed value. The relative number of species is defined in the **Plant object** dialog.

The **distribution and positioning** of the objects can be influenced as follows:

- **randomly distributed (evenly)**  
the objects are distributed evenly in the bed without a recognizable pattern.
- **randomly distributed (concentrated)**  
the objects are distributed evenly without a recognizable pattern in the center of the bed.
- **in rows**  
the number and orientation are variable
- **as a roundel (evenly)**  
evenly distributed as a roundel, the number of rings and the inner radius are variable
- **as a roundel (radial)**  
as before, but the distribution density decreases towards the outside

If you use several 3D objects, the **distribution** can be defined:

- **random**  
the objects are alternated randomly
- **Piece by piece**  
the objects are placed one after the other
- **Rows or rings**  
one object after the other is used for each row or ring.

## 14.8 Fences

Clickon the **Fences** button  in **Terrain** mode.









A fence is placed as an outline on the terrain; the fence follows the height of the terrain. 3D objects are automatically placed along the contour of the fence polygon.

### 14.8.1 Draw fences

Fences are always placed in the terrain layer. However, this assignment can be changed at a later date.

 Possible input options:

#### Input types

- **Automatic contour recognition for terrain areas**   
Required input: 1 point  
The contour of the fence is automatically determined within a drawn terrain area.  
The **Show objects during input** option has no effect with this input type.
- **Fence side**   
Required input: 2 points  
The fence is entered via two end points.
- **Polygon**   
Required input: n points  
The bed is entered using any number of corner points. End the entry with **[Esc]**.
- **Polygon with fixed width**   
Required input: n points  
The fence is entered using any number of corner points. The result is a "band" of the set width with a closed contour. End the input with **[Esc]**.  
 Additional possible input options:  
**Width** - the width of the polygon.
- **Rectangle**   
Required input: 2 points  
The fence is entered using two opposite corner points.
- **Rotated rectangle**   
Required input: 3 points  
First define one side of the rectangle with two points. The height of the rectangle is defined with the third point.
- **Spline**   
Required input: n points

The fence is drawn as a spline with any number of corner points. End the input with **[Esc]**.

## 14.8.2 Property dialogs

### Catalog

Component templates are offered in the catalog. If you select a component template, all parameters of the fence are adjusted.

You can find further information on [catalogs](#)<sup>[150]</sup> in the General *properties* dialogs chapter.

Further information on the properties [Layer](#)<sup>[143]</sup> and [Size/Position](#)<sup>[143]</sup> can be found in the General *properties* dialogs chapter.

### 14.8.2.1 Border object

3D objects can be lined up along the side edges of a fence.

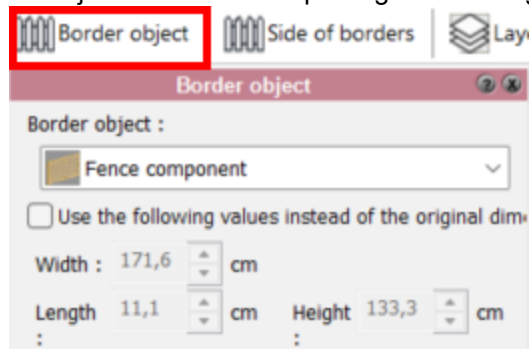

Select the desired object from the selection list. If no borders have yet been used in this project, only the **Load object** entry is available in the selection list. This allows you to select a 3D object from the object library.

If a 3D object is selected, the dimensions of the object are displayed in the **Width**, **Length** and **Height** fields. Optionally, these values can also be changed.

### Border

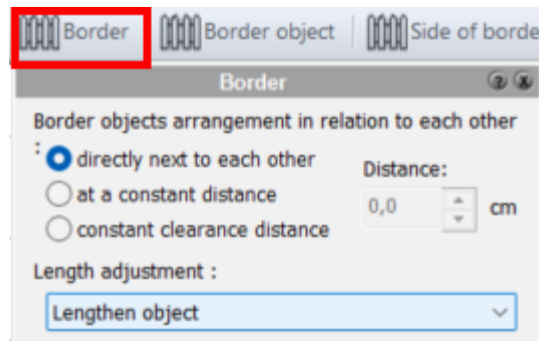

In the **Border** properties dialog, you specify whether the objects along the side edges

- directly next to each other (without spacing)
- with constant spacing (distance from axis to axis)
- with a constant clearance (distance between the objects). The spacing for the 2nd and 3rd option is set in the input field.

### Extend objects

The objects are automatically placed along the side edges. The object is inserted as often as the object width and the selected optional distance between the objects allow. However, for all side lengths not equal to a multiple of the object width plus the distance, a residual piece remains.

If you select **Extend objects** in the selection list, you can set how this remaining piece is divided up.

- Extend objects  
The object width is increased so that there is no remaining piece.
- Leave space at the beginning  
The remaining piece is left free at the beginning of the page.
- Leave space at the end  
The remaining piece is left free at the end of the page.
- Leave space at the beginning and at the end  
Half of the remaining piece is left free at the beginning and half at the end of the page.
- Extend the space between the objects  
The distance between the objects is increased so that there is no leftover space.

### Border pages



In this dialog, select which side of the fence is to be equipped with border objects.

## 14.9 Terrain modeling (Delaunay triangulation)

### 14.9.1 General information

**Delaunay triangulation** is a common method for creating a triangular mesh from a set of points. It is named after the Russian mathematician Boris Nikolayevich Delone (1890-1980, French form of the surname: Delaunay), who dealt with it in a publication in 1934.

Application:

With the Delaunay triangulation method, points in the  $\mathbb{R}^2$  are meshed to form triangles in such a way that no other points are contained within the circle on which the three triangle points lie. This method is used, for example, to optimize calculation meshes for the finite element method.

In a Delaunay triangulation, all triangles of the triangle mesh fulfill the so-called circumcircle condition: The circumcircle of a triangle of the mesh must not contain any other points of the specified point set. As a result, the triangles of the mesh have the largest possible interior angles; mathematically speaking, "the smallest interior angle is maximized over all triangles". This property is highly desirable in computer graphics, as it minimizes rounding errors.

The Delaunay triangulation is not unique if there are more than three points on a circumference, i.e. the user can arbitrarily choose which three points to connect to form a triangle.

In three-dimensional space, the analogous circumcircle condition is used instead of the circumcircle condition, which then generates a tetrahedron from every four points.

#### Connection with Voronoi diagrams

The Delaunay triangulation is the dual graph of the Voronoi diagram of the point set: The vertices of the Voronoi cells are the circumcircle midpoints of the triangles of the Delaunay triangulation (the Voronoi cells are obtained by drawing the mid perpendiculars of all triangle sides up to the common intersection point with the other two midperpendiculars of the same triangle; this point may, for obtuse-angled triangles, lie well outside the triangle area, for right-angled triangles it is the point that bisects the hypotenuse).

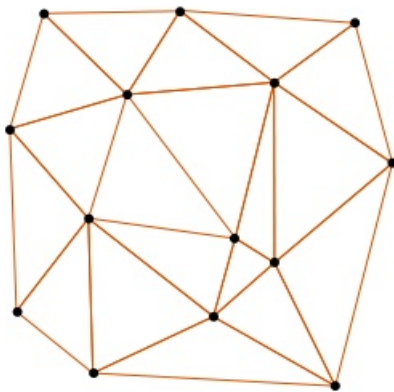

Delaunay triangulation of a set of points in the plane.

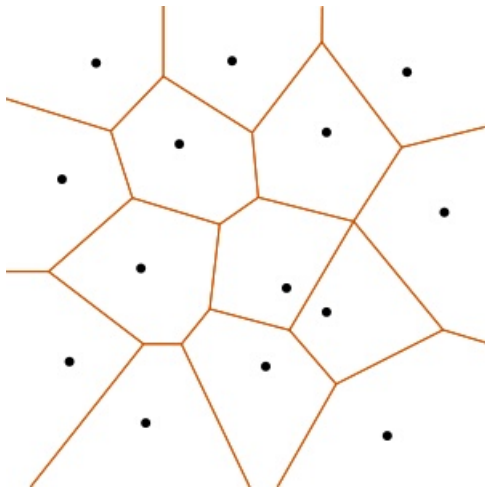

Voronoi diagram of the same set of points.

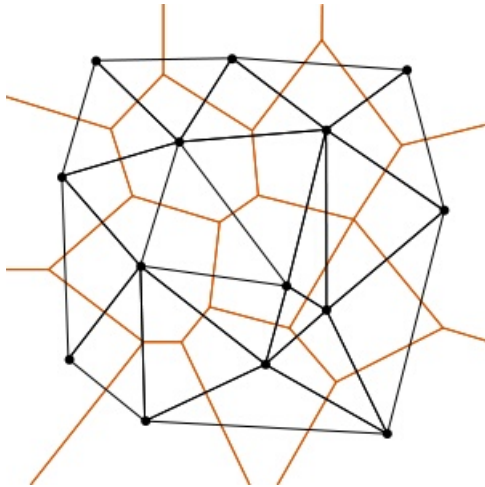

Voronoi diagram (orange) and Delaunay triangulation (black)

[Source: <https://de.wikipedia.org/wiki/Delaunay-Triangulierung>]

### 14.9.2 Insert geometer data

Geometer data can be imported in terrain mode and is then displayed in three dimensions. The following geometer files can be read in:

- **ASCII files**
- **XLS files**



The 'Import surveyor data' command is located in the day bar

The corresponding file is selected:

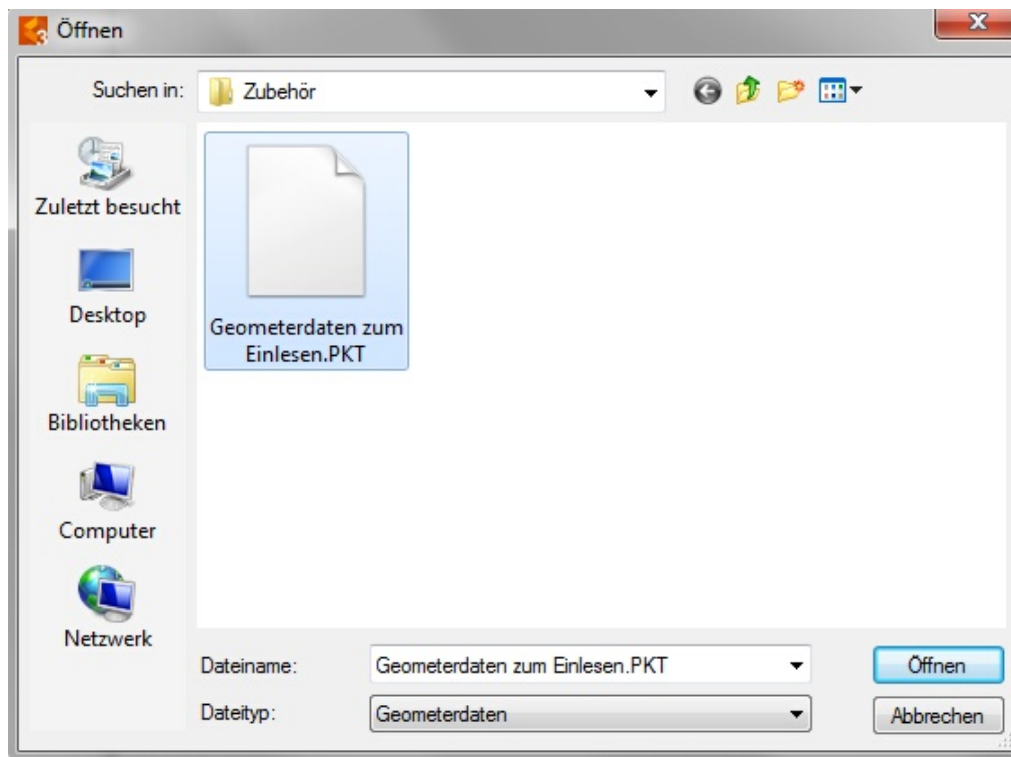

The corresponding settings can still be made:

Geometerdaten

F1	F2	F3	F4	F5
HA1003...	9040	346183...	556041...	328.575
HA1003...	9040	346185...	556041...	328.689
HA1003...	9040	346186...	556045...	334.052
HA1003...	9040	346186...	556045...	333.663
HA1003...	9040	346186...	556043...	331.609
HA1003...	9048	346185...	556042...	330.480
HA1003...	9049	346185...	556041...	328.687
WP538	9040	346180...	556037...	323.773
WP537	9040	346179...	556037...	323.922
WP536	9040	346179...	556037...	323.839

Bezeichnung X Y Z

in Spalte

Einheit der Geometerdaten :

	Minimum	Maximum	Bereich
X	3461746,5 m	3461877 m	130,53 m
Y	5560375,5 m	5560459 m	83,58 m
Z	323,246 m	334,052 m	10,806 m

In Ursprung verschieben :

Höhe Gebäudeniveau Null :  m

Beeinflusste Gelände :

Grundstück erzeugen

Interaktiv einfügen

The 3D points are attached to the cursor and are placed on the drawing surface:

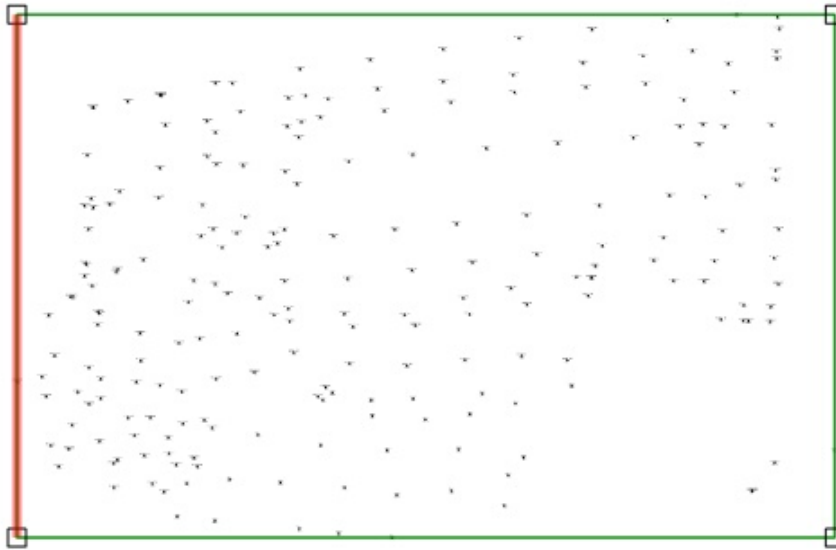

The terrain and all elevation points are now visible in three dimensions:

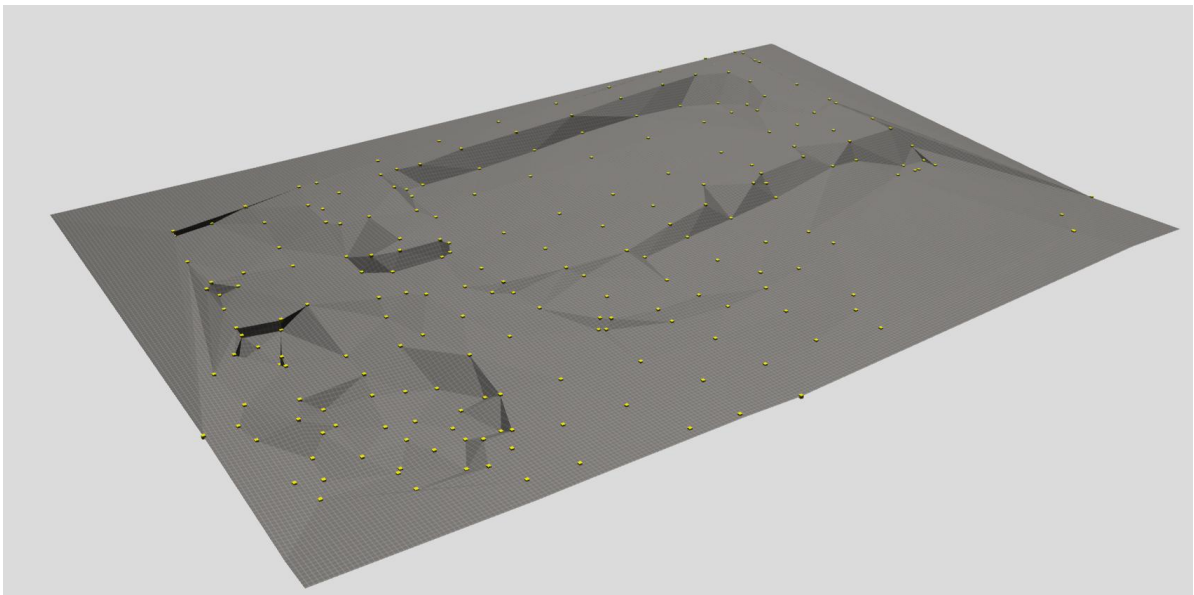

### 14.9.3 Settings

Various settings can be made for the terrain under the menu item **Terrain|Parameters|Settings** :

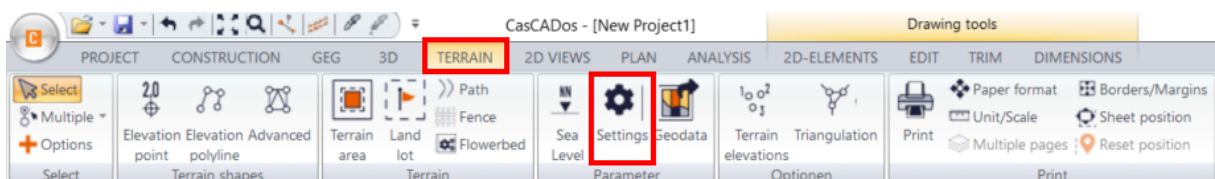

General terrain settings: The landscape display can be switched off so that the property is more visible:

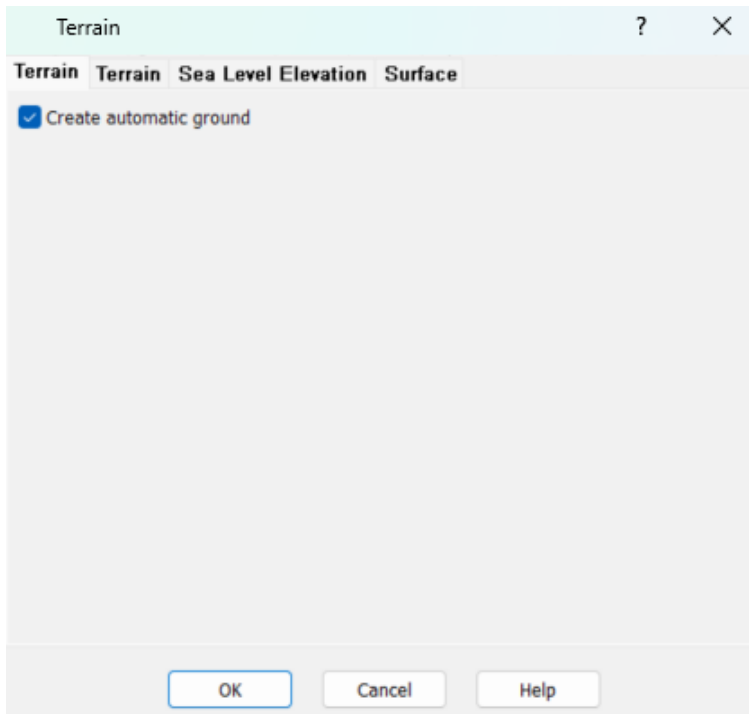

Detailed terrain settings:

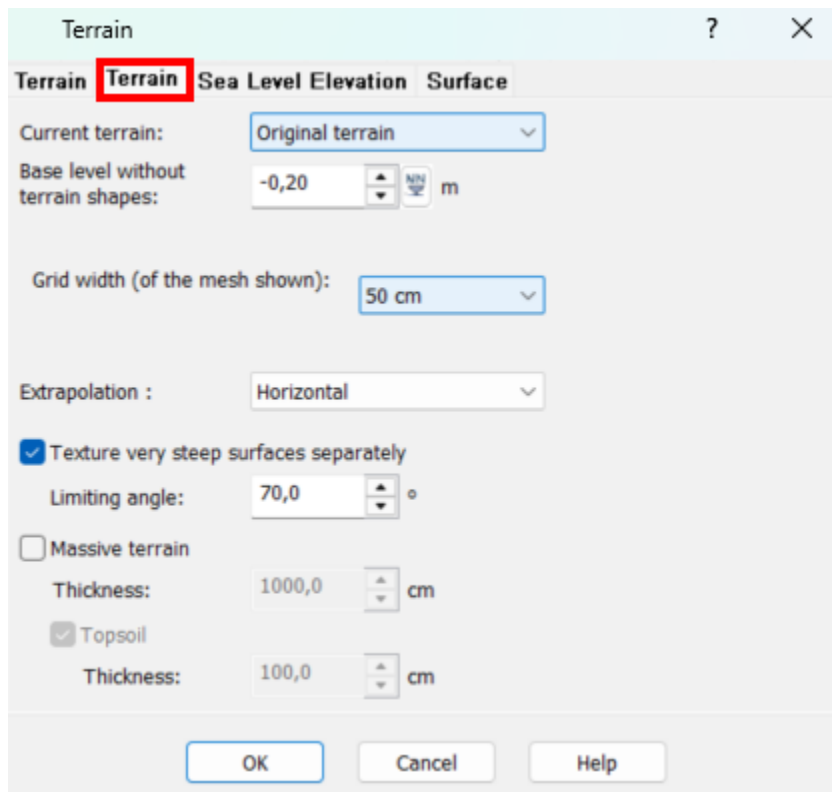

Current terrain:

A distinction can be made between the **original terra** in and the **projected terra** in:



Entries e.g. elevation points apply to one or the other terrain or simultaneously to both terrains!

Base level:

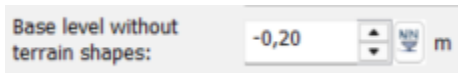

e.g. a base level can be assigned to the entire terrain

Important settings are still available:



This gives you a good representation in 3D mode:

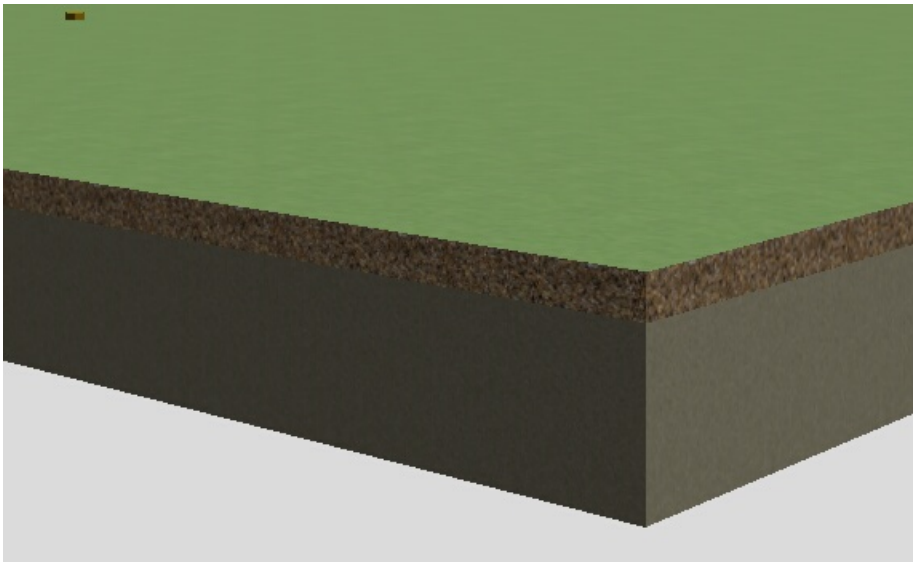

Settings Height above normal zero

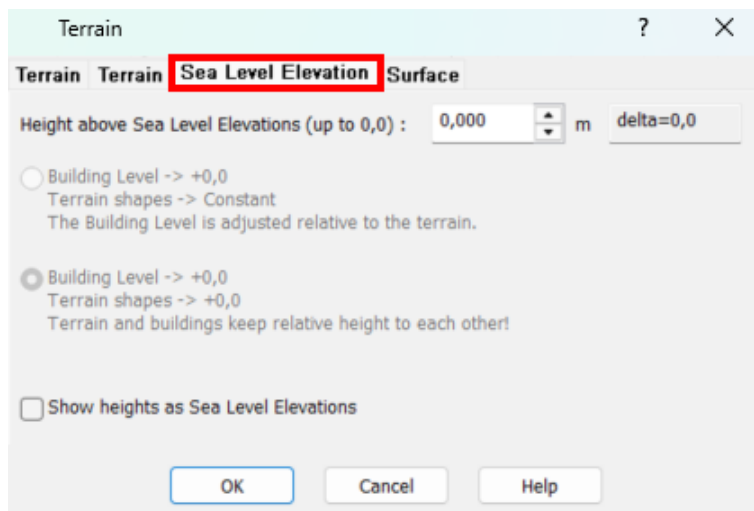

(These options also appear when you click on the button  )

In order to be able to work with the real heights, the 0.00 height OKFF EG is assigned to a height above zero

The settings for the textures can be predefined for the surface:

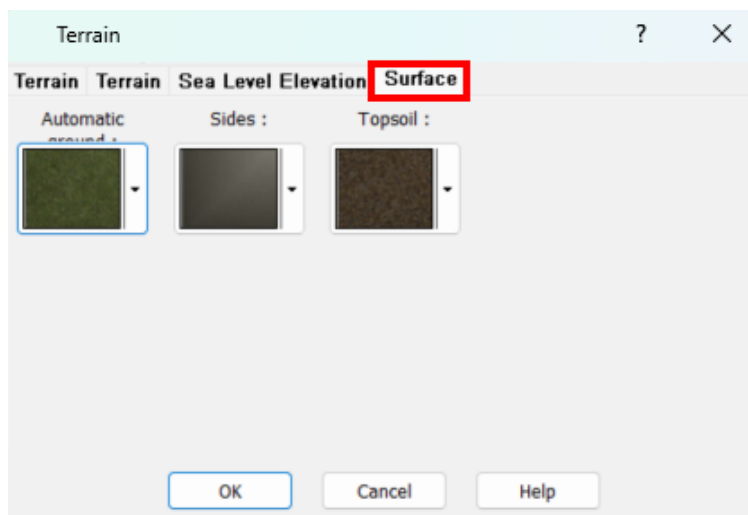

#### 14.9.4 Terrain types

We distinguish between the

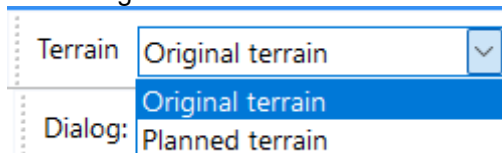

**Original terra** in: includes the heights that are decisive before the start of construction

**Projected** terrain: contains the heights that are decisive as finished terrain

Both terrains can be edited and displayed separately, this also works in the section views!

### 14.9.5 Subsequent processing

**Vertical surfaces:** Elevations can be provided with exactly vertical slopes.

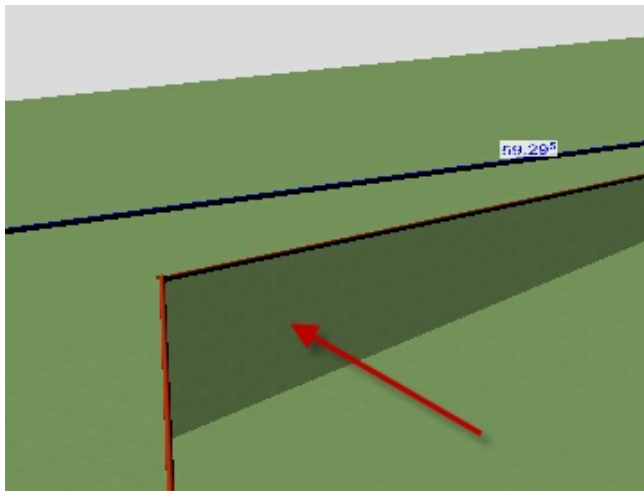
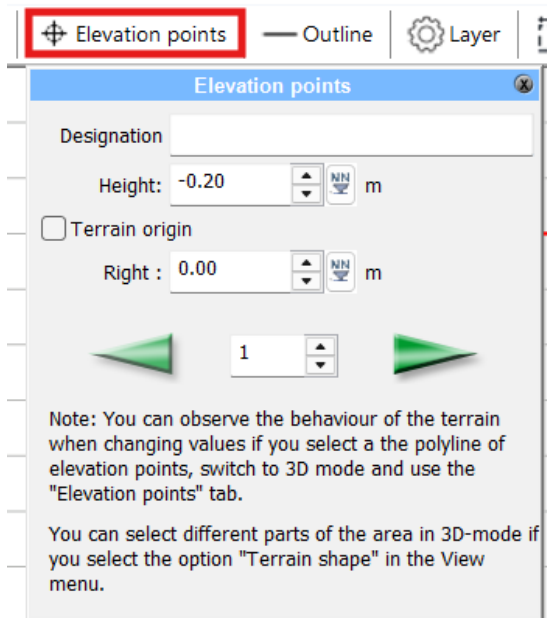

- Points can be subsequently inserted or removed from contour lines

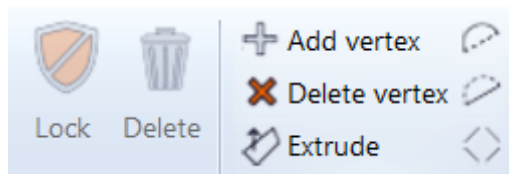

#### Further editing options:

- Change elevation together by difference amount
- Change elevation points vertically in 3D using drag & drop
- Point labeling - directly selectable for input

## 14.9.6 Representation

Display options:

- **Labeling of height points** - Point number/height

HA260309088

○  
+326,2

- Selectable size/color of terrain shapes
- **Grid for terrain display** - freely selectable size

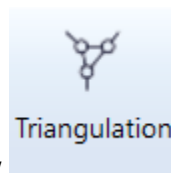

- **Show triangulation in plan view**
- Display of elevation shapes in the currently switched terrain (original terrain/projected terrain)

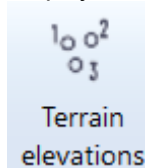

The terrain shapes can be displayed in the 3D view if you activate the **View|Terrain shapes** function.

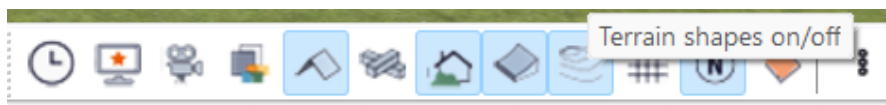

The display options are selected in the menu bar under **Options|Terrain shapes...** :

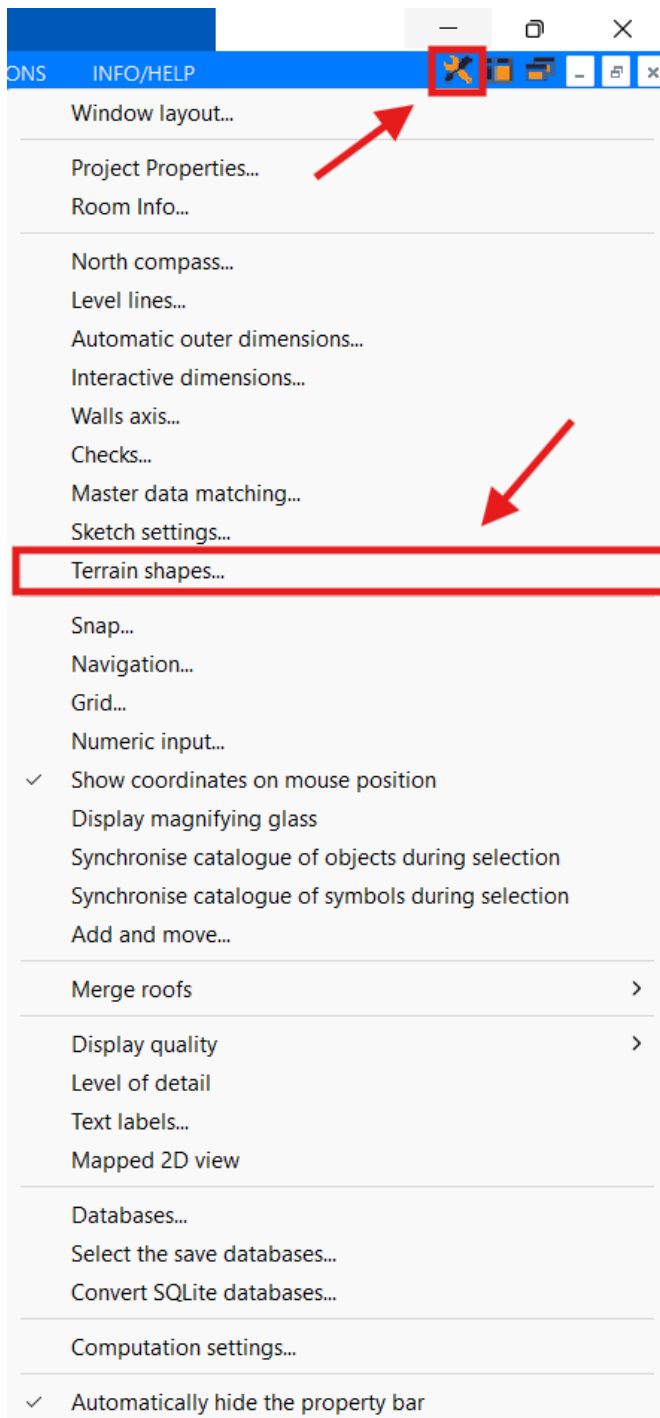

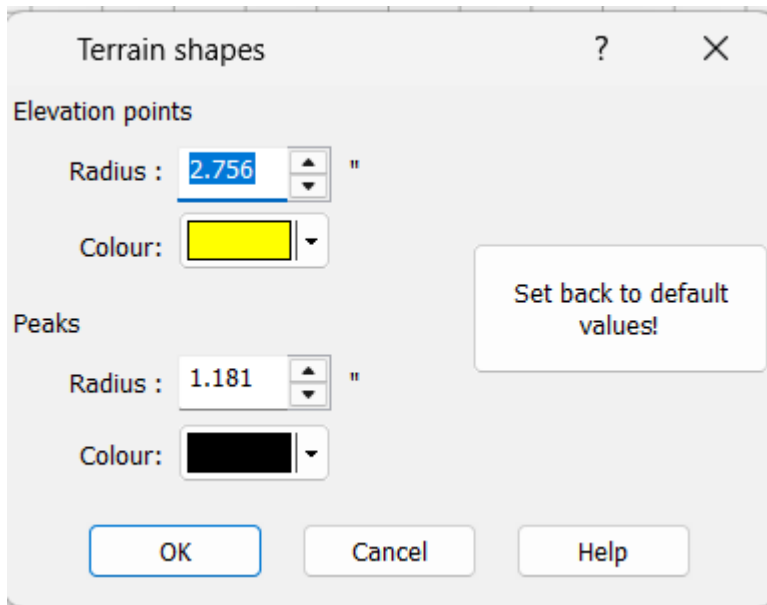
**Options:**

Elevation points

Radius cm

Color Selection

Ridges

Radius cm

Color selection

Reset to default values!

Show the terrain grid under menu **View**|**Terrain grid**:

## 15 2D views

### 15.1 Introduction

**Views, sections**, views of the 3D model (*perspectives* or isometrics) and 2D drawings generated from the floor plan are referred to as 2D views. These views each have their own layer structure that is independent of the model. The layers of the construction are not listed in the layer management of views. However, you can define separate layers for each view. This is particularly important in connection with labels, dimensions or additional features (trees, etc.).

A 2D view is generated from the model. If the view is a view or a section, the view remains linked to the model. Changes in the model (e.g. in construction mode) are updated in the view as required. If a floor plan view is converted from construction mode to a 2D view, there is no connection to the model. The result is 2D elements.

To display a view or a section, it is necessary to hide the hidden edges that are not visible. This is done automatically when the 2D view is created and is recalculated when it is updated. The calculation process for hiding (in the menu bar under: **View|Hide**) can take some time, especially for large projects.

### 15.2 Overview

**Plan7Architect** provides **the following 2D views**:

2D view	Application	Properties
<b>Free view</b>	Drawings completely independent of the model (details, system sketches, etc.), a new view opens without content.	No updating No hiding of lines No dissolving
<b>Free view from K mode</b>	Like free view, but with the floor plan of the construction mode broken down into 2D elements. See also Project view.	No updating No hiding of lines No dissolving
<b>View</b>	Predefined views of the model (front, back, right, .....)	Refresh Hide lines Dissolve
<b>Section</b>	2D view from a section line defined in the floor plan (any angled views can also be created in this way)	Refresh Hide lines Dissolve
<b>Project view</b>	View of the floor plan in construction mode.	Always updates automatically. No hiding No dissolve
<b>3D view (Persp.)</b>	Creates a 2D view of the 3D display. The viewing point is taken from 3D mode.	Refresh Hide lines Resolve
<b>Parallel 3D view</b>	As before, but as a parallel projection	Refresh Hide lines Resolve
<b>Isometry</b>	As before, but as isometry from	Refresh

	a defined viewpoint.	Hiding lines Resolve
<b>BGF, KGF, BRI, KRI</b>	Special variant of the project view. Displays the comprehensible calculation of the corresponding key figures in the floor plan.	Always updates automatically

With the exception of the **free views**, the type of display can be selected for each of the 2D view variants listed.

### 15.3 Free 2D view

Free 2D views are used to create 2D drawings independent of the building model. One area of application would be detailed drawings. In 2D views mode, all functions for 2D design are available to you.

Switch to **2D views** mode and select **Add new 2D view...** from the Views selection list :

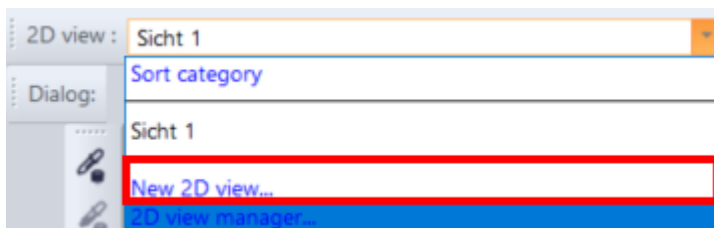

Now select **Free view** in the selection list and confirm the selection with **OK**.

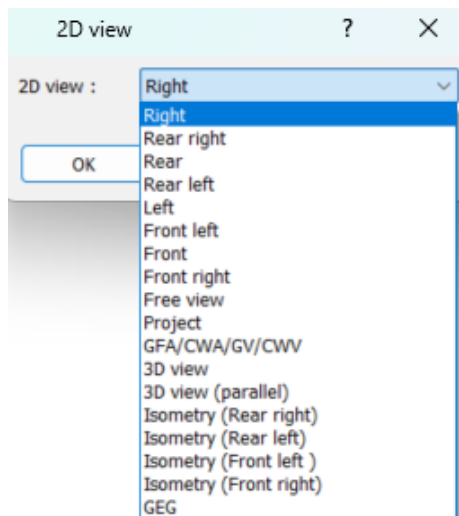

You can now enter the name and scale of the view.

In free 2D views, there is no updating, no visible storeys or layers of the building model. They have a layer structure that is independent of the model.

## 15.4 Views

Switch to the "**2D views**" mode.



If you have already created a 2D view in this project, it will be shown.

To create a new view, go to the **2D** menu bar and select **Views|Add new 2D view...** and the **2D view** dialog appears.

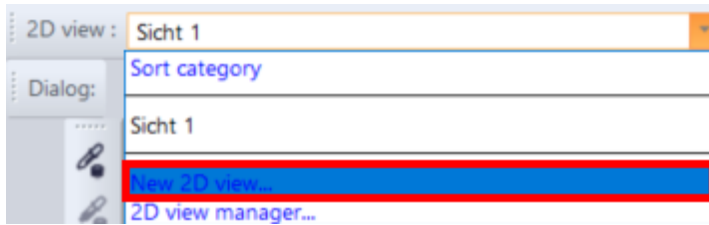

If there is no 2D view in the project yet, the dialog appears immediately after switching to **2D views** mode.

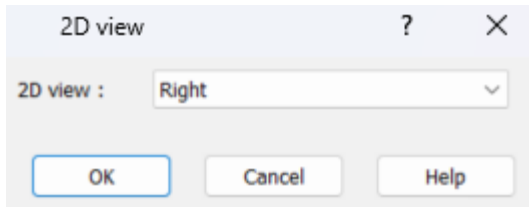

for the view and confirm the selection with **OK**. Eight predefined viewing directions are available; their viewing direction does not depend on the north direction or the orientation of the building in the plan.

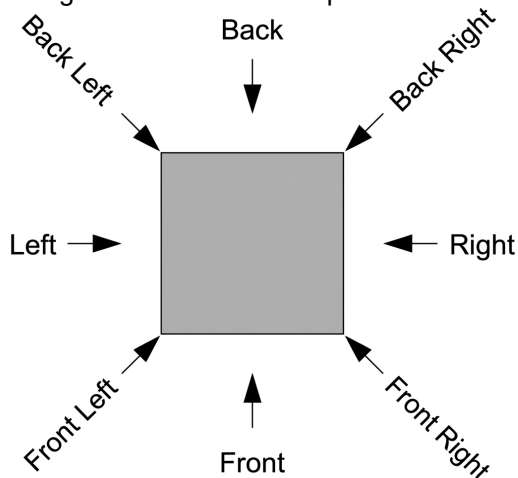

Free views with any angle of view of the object are defined like a section. More information on this can be found in the following chapter **Create section**. The view is stored on the Contours layer.

## 15.5 free view

In addition to the sections, 'free views' can be created.

These free views are placed in the **construction mode** via two points

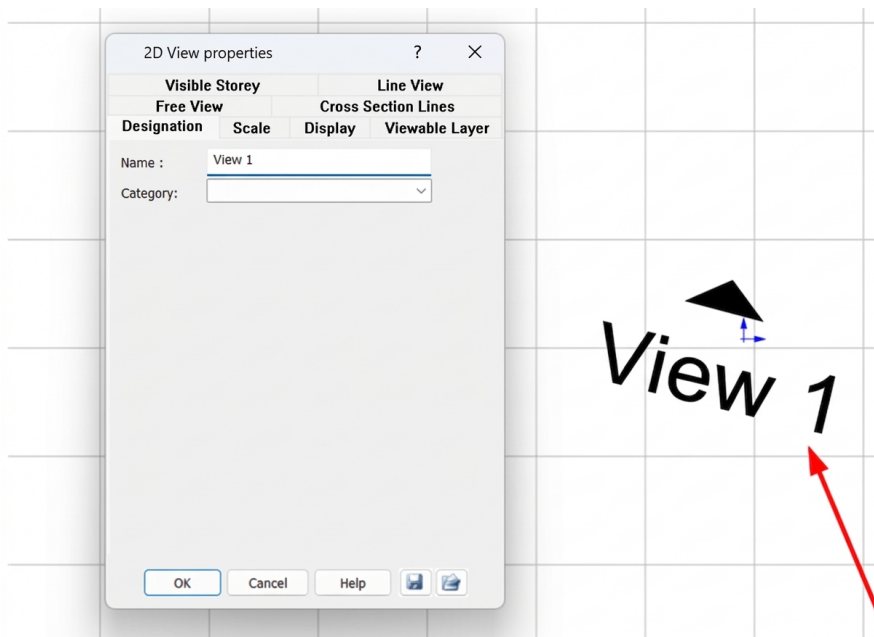
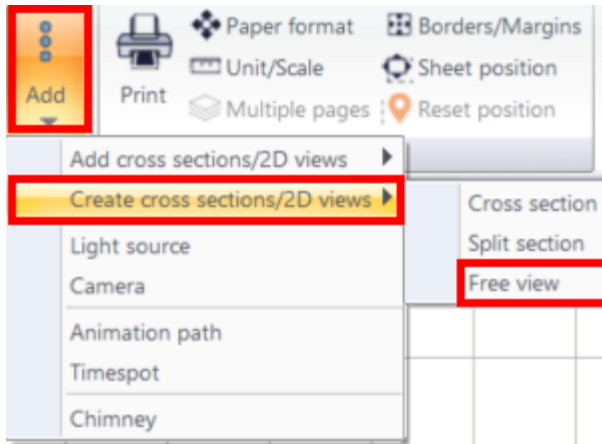

You are also immediately taken to the settings:

Once all settings have been made there, the view is created by pressing the 'OK' button.

## 15.6 Delete 2D view

A 2D view can be deleted with the command Menu bar **2D views|Delete active 2D view**.

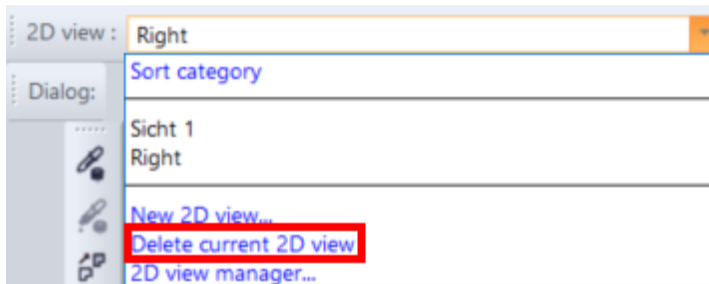

## 15.7 Cuts

A section is created with a section line in construction mode.

To do this, select **Insert** then **Create sections/views** in the construction bar and then the input type **Section**.

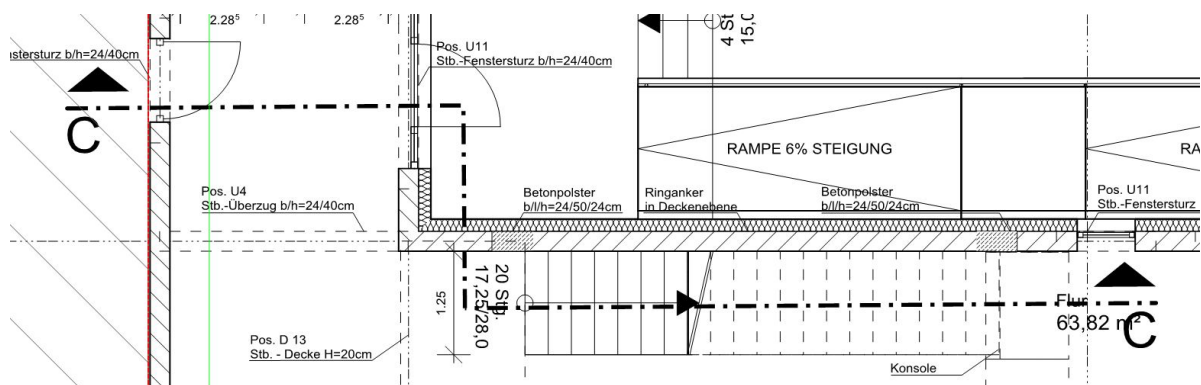
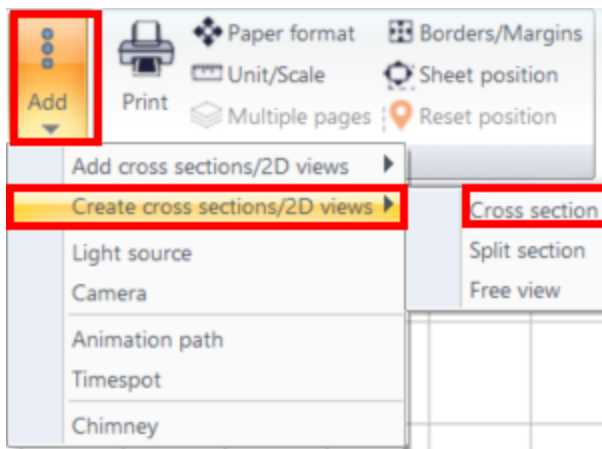

### 15.7.1 Create cutting line

Before a section can be calculated, a corresponding section line must be created in the construction:

Click on **Add** then on **Create sections/views** and select the type of section line from the selection bar:

**Cross section**

**Split section**

The section line is created counterclockwise. Once the cutting line has been set, the following dialog appears:

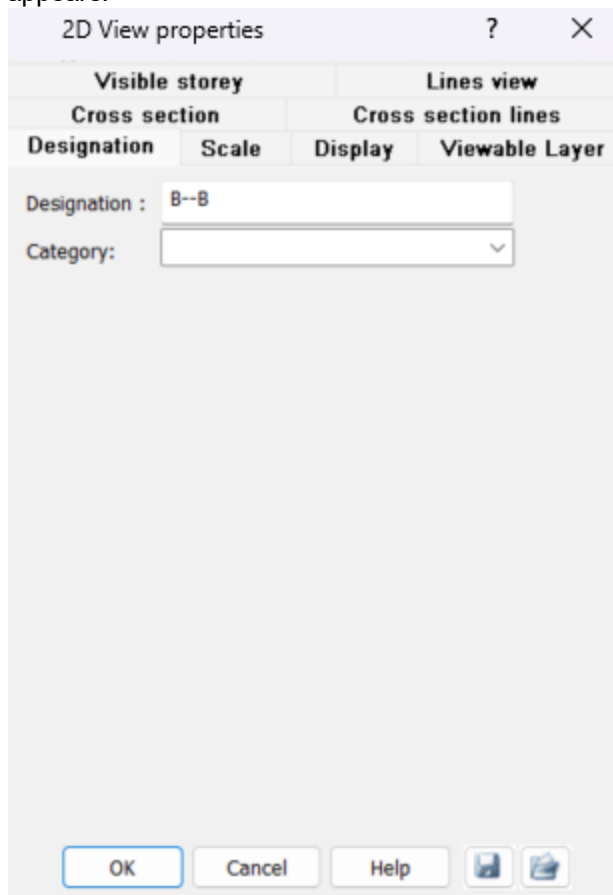

Once all settings have been made, the section is created by pressing the 'OK' button. If this dialog is cancelled, a section must be created under the 2D views as described below.

### 15.7.2 Properties of the cutting line

Select the section line by clicking on it in construction mode. The properties dialogs for the section line are displayed. Select the **Section** properties dialog. The **Section** dialog opens

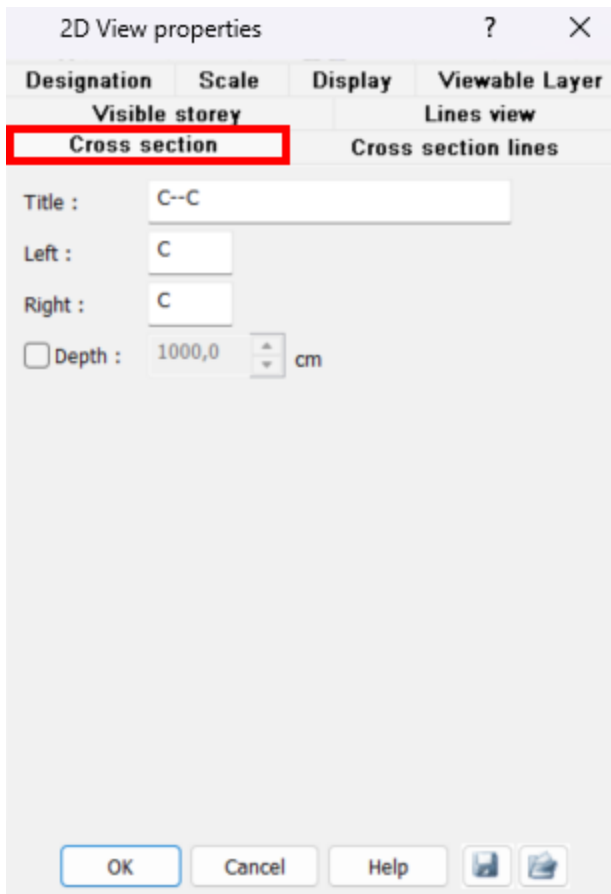

**Title:** The title of the section is suggested, but can be freely changed. This name of the section is used in the selection lists of the 2D views and plan layout modes.

**Left and right:** The labeling of the section line is also suggested automatically and can be changed freely.

**Depth:** Select this radio button and enter the visible depth of the section. All elements outside the visible depth are now hidden in the section.

### 15.7.3 Edit cutting line

#### Properties of the cutting line

The properties of the contour can be defined for the cutting line. Select the cutting line by clicking on it and open the **Contour** properties dialog. The thickness, line type and color of the cutting line can be changed in this dialog. Click on the section line to select it and open the **Section symbols** properties dialog. The size and type of the symbol and text can be changed in this dialog.

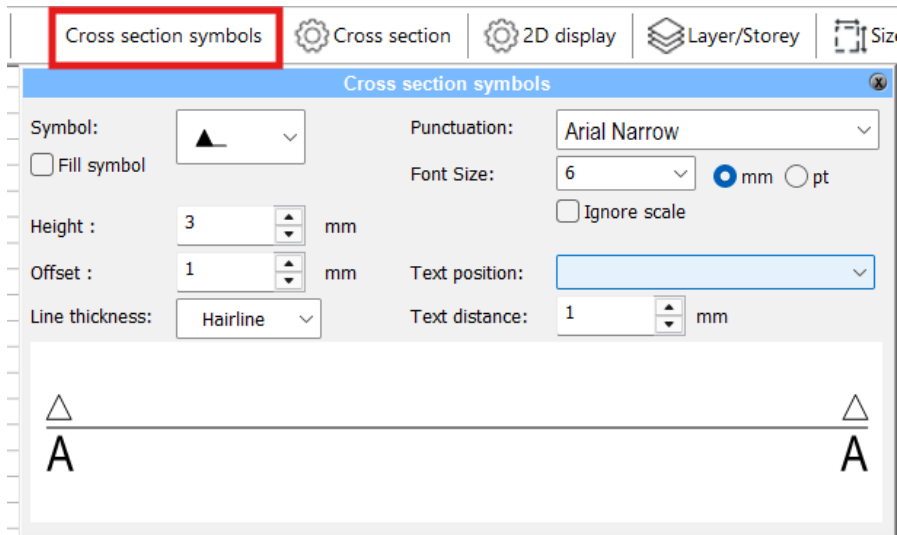

### Move cutting line

If a section line is moved in construction mode, the display in the associated 2D view also changes. To move a section line with the mouse, select the section line and drag it to the desired position with the mouse.

The position of the section line can be defined with coordinates using the **Size/Position** properties dialog. This dialog also contains the numerical input of the length and angle of the cutting line.

The **Move** command can also be used for section lines, e.g. to move a section line exactly 1.00 m.

### Delete cutting line

Select the cutting line and press the **Del key** or **Edit>Delete** in the menu. The section line is deleted and only the additionally drawn elements remain in the 2D views created from it.

## 15.7.4 Properties of the sections and free views

Many settings can be made in the sections and free views, which enable a correct display in the 2D views.

After setting the section line or the free view, the following dialog box appears...

This can also be called up in the 2D views under **2D views|Options...** can also be called up:

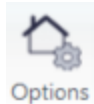



Dialog box:

2D View properties ? X

Viewable Layer	Visible storey	Lines view
Designation	Scale	Display

Designation :

Category:

OK Cancel Help  

The title for the section or view can be entered in the **name** field; this will then appear in all selection bars:

2D view :

Under **Scale**, the scale for this 2D view can be set, either the same as the project scale or different:

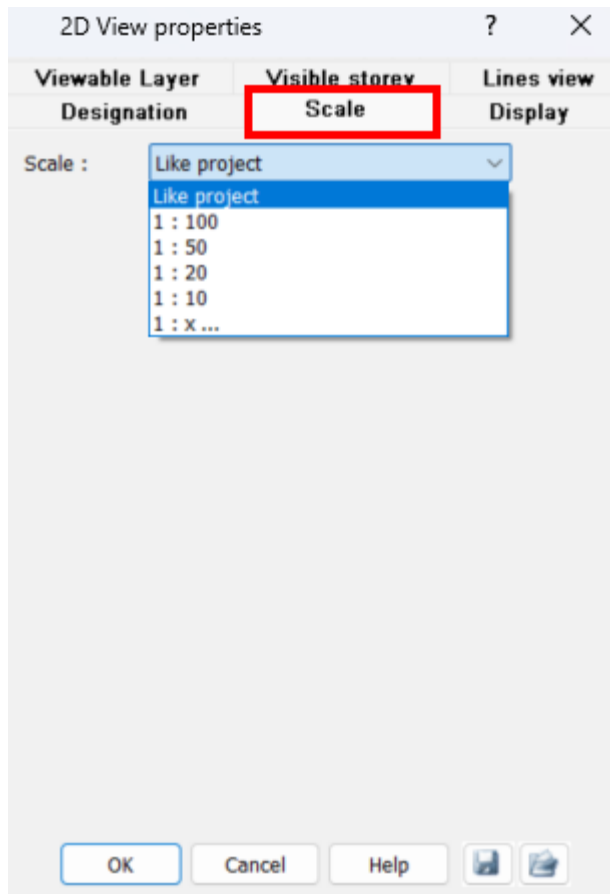

A wide variety of settings for the views are possible in the **Display** tab. Here, for example, you can also 'Show' the timber construction or 'Switch off' the north direction:

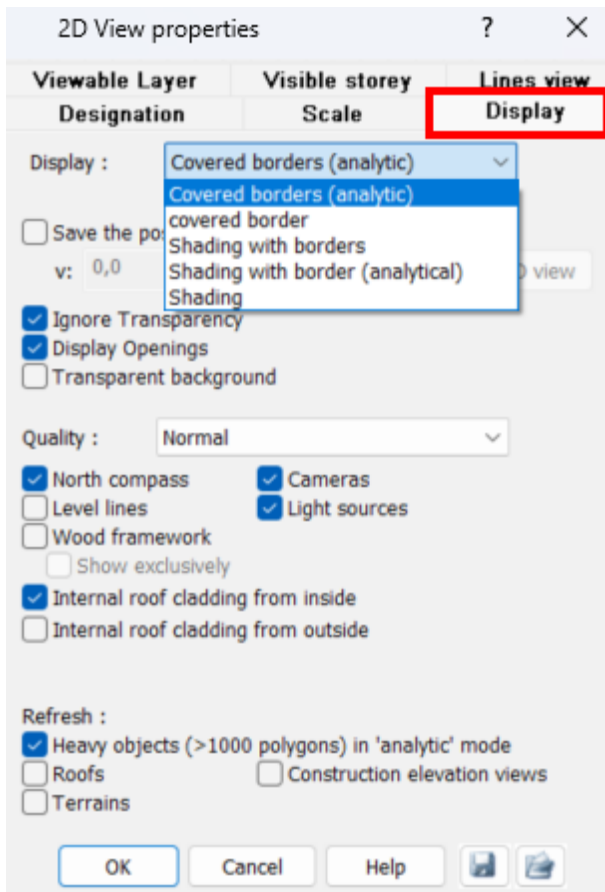

All settings for the calculated lines that are not cut are made in the **View lines** tab:

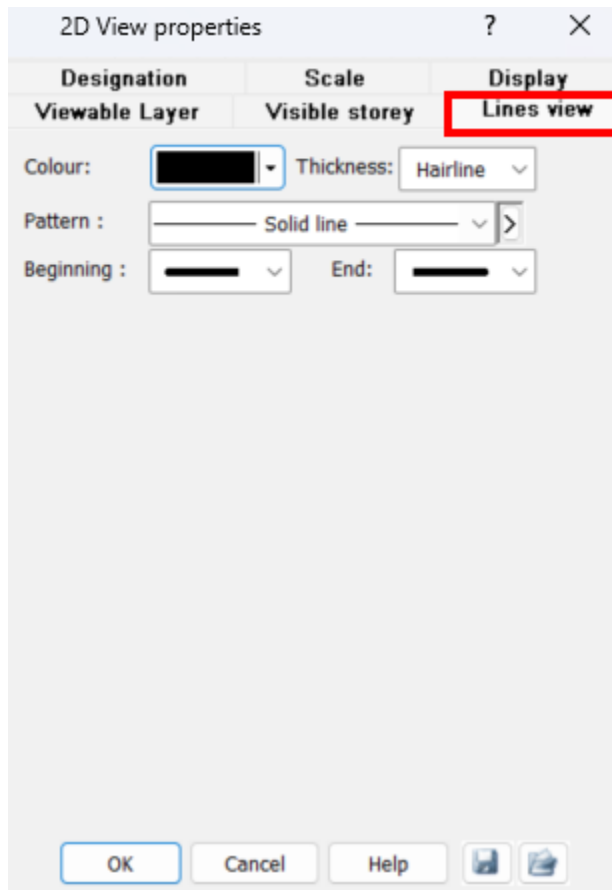

Under **Section**, the properties of the section line are set, as well as a possible depth limit in the section:



**Cut lines** is about the detailed settings for the cut components:

Standard : ...

Slabs : Of the type ...

Storey Slabs : Of the type ...

Floor detail : Of the type ...

Walls : Of the element ...

Wall Layers : Of the element ...

Wood framework : Of the element ...

Roofs : Of the element ...

Chimneys : Of the element ...

Columns/Posts/Pillars : Of the element ...

Platform/Slab/Panel : Of the element ...

Beam : Of the element ...

Profiled beam : Of the element ...

Raft foundation : Of the element ...

Strip foundation : Of the element ...

Pad foundation : Of the element ...

Original terrain : Of the type ...

Terrain planned : Of the type ...

Terrain edges d = 0,000

Fills up to z = 0,000

OK Cancel Help

A wide variety of settings can be made there for all components, which can be used from the design to calculate the cut.

First of all, standard settings can be made by clicking on the three dots behind "Standard":

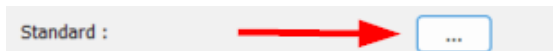

This takes you to the following settings:

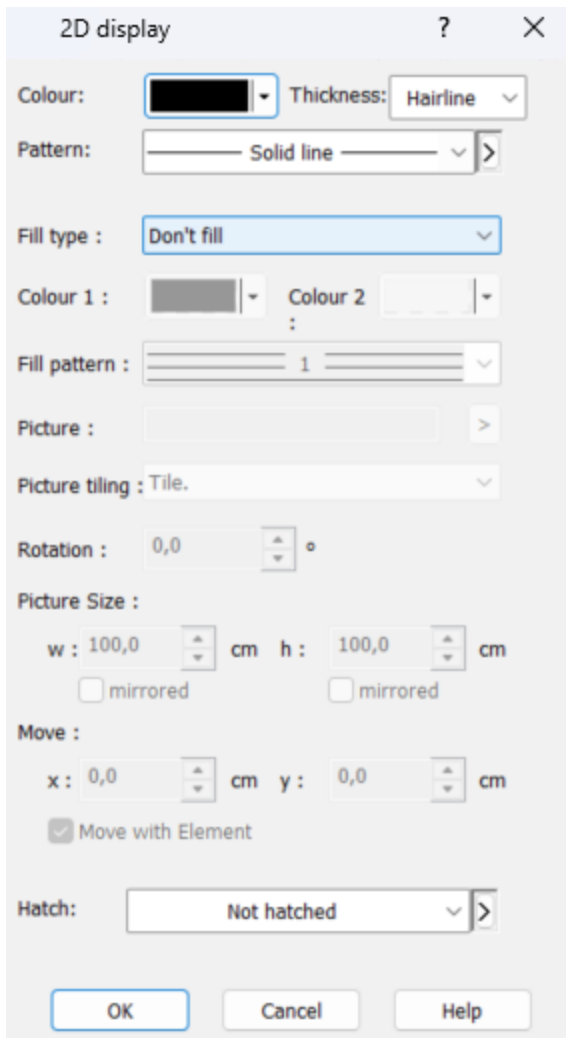

Settings that are frequently used can be made here for a cutting standard; the method of operation is analogous to the other identical setting options.

For each component separately, you can now determine whether the section standard should apply:

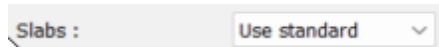

whether the properties of the element should come from the design:

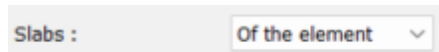

or whether a separate standard should be set for this type:

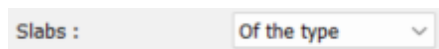

To do this, click on the three dots again and make the settings!

### Hiding element edges below the terrain

Original terrain :	Of the type	▼	...
Terrain planned :	Of the type	▼	...
Terrain edges d =	0,000	▲	▼
Fills up to z =	0,000	▲	▼

The building parts below the edge of the terrain can be automatically hidden in free views and sections. The following settings are required for this:

1. enter the original terrain or the projected terrain in the model
2. select the desired terrain for the display
3. specify the fill and hatching for the terrain type (see dialog above)
4. thickness of the terrain edge d in meters (e.g. 1.00 m)
5. fill up to z defines the z-height up to which the edges are covered. (e.g. -5.00 m)

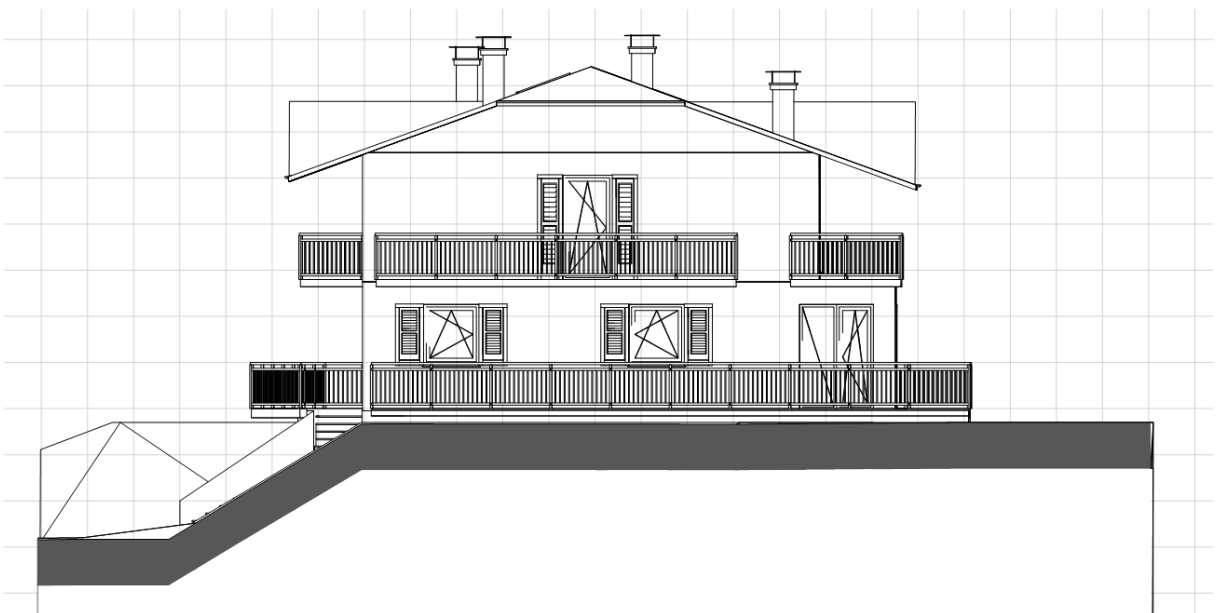
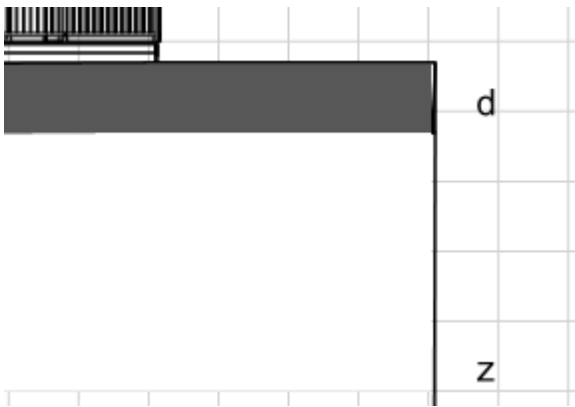

Settings for the [visible layers](#)<sup>1131</sup> and the [visible floors](#)<sup>1261</sup>:





this controls which layers and which storeys are used for the section calculation. In particular, you should only select the layers that are relevant for the section to save unnecessary calculation time!

#### 15.7.4.1 Create cut

The section is created from a drawn section line in **2D views** mode. To do this, select the **New 2D view** entry from the **Views** selection list. The dialog for selecting the section properties opens:

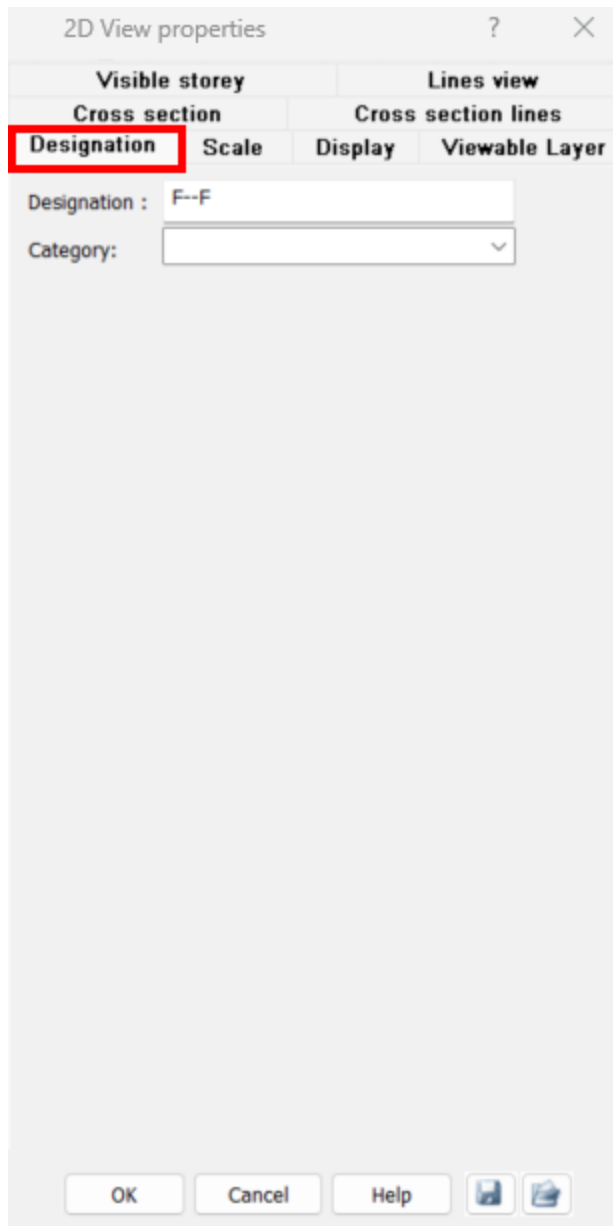

Select the section from the selection list and confirm with **OK**. The section is created.

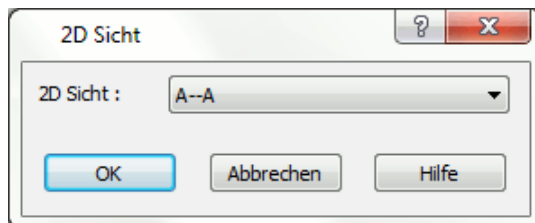

Three layers are created:

- Cut edges, for all cut edges
- Cut surfaces, all cut surfaces (filled, hatched)
- Contours for all non-cut edges (view)

## 15.8 2D views of the construction (floor plan)

### 15.8.1 as an unobstructed view with the crumbling floor plan

This function can be used to convert floor plans from **construction** mode into a 2D view. All components "break down" into 2D elements such as lines, arcs etc.

The 2D view is no longer linked to the model. Changes to the model are therefore not updated in the 2D view. The **Calculate 2D layer** button is not active.

This function is used if the plan is to be completed exclusively with 2D functions, e.g.

- a site plan that is created based on the plan view from the model
- Detailed drawings from the floor plan

Procedure:

- In construction mode, make all storeys and layers visible that are to be included in the 2D view.
- In the **View** menu, click on **Convert to 2D view...**

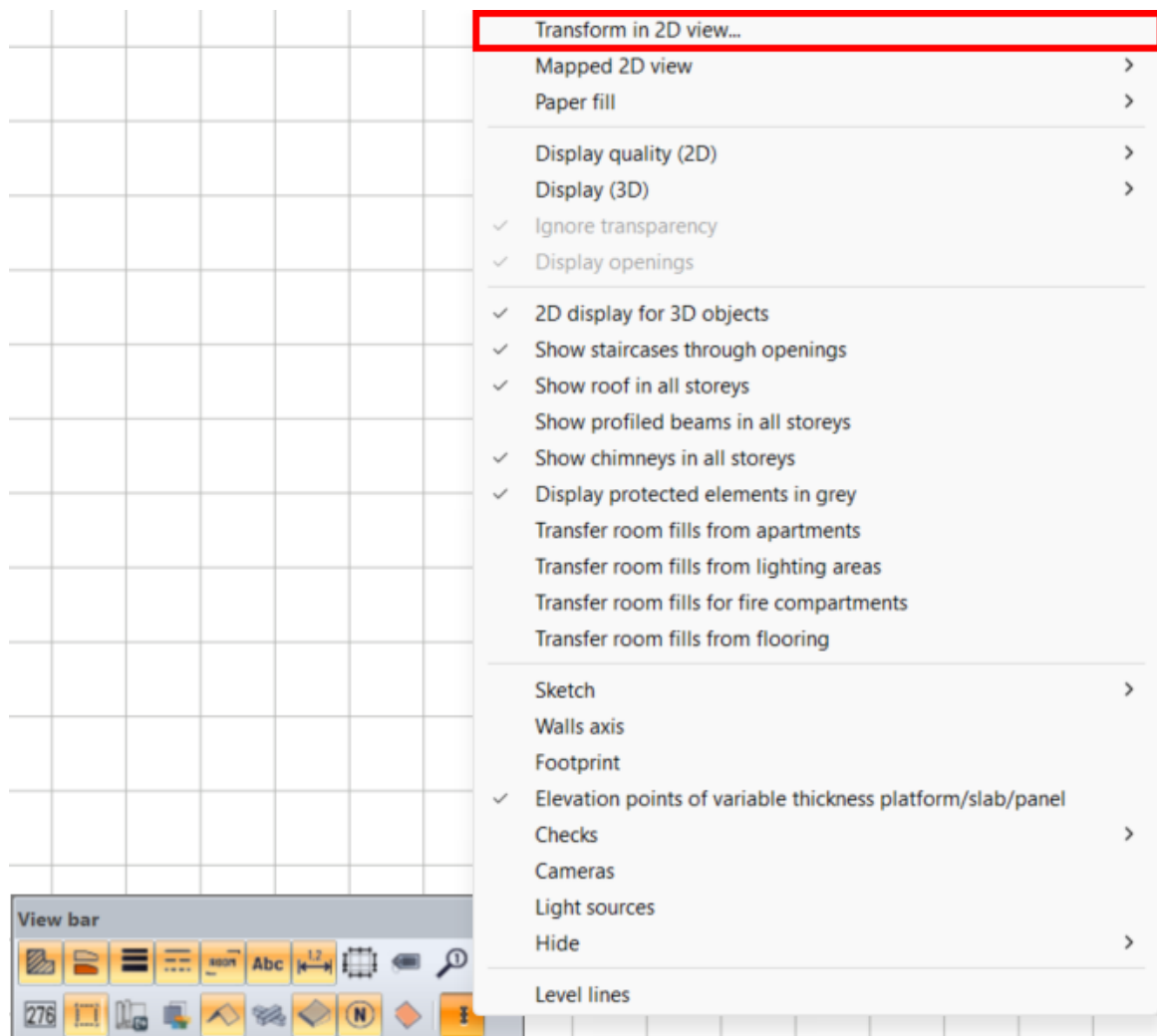

- Enter the name of the new 2D view and confirm with **OK**.

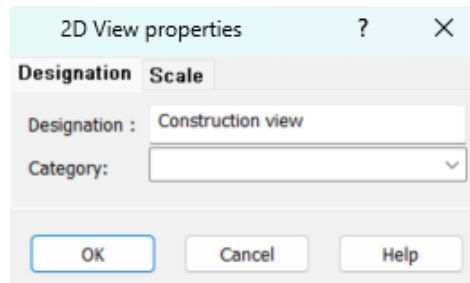

The 2D view is now created. The layer structure of these 2D views corresponds to the structure in construction mode.

### 15.8.2 as a view of the floor plan

This procedure is recommended for creating a 2D plan based on the construction view (building floor plan), but changes to the building are automatically updated.

- **Advantage:** automatic updating
- **Disadvantage:** the model can not be edited. Only the visibility of the buildings and layers can influence the display.

Procedure:

- Switch to the 2D views mode
- In the **View** menu, click on **Convert to 2D view...**
- Enter the name of the new 2D view and confirm with **OK**

The 2D view is now created.

## 15.9 Display of 3D content in 2D views

The following 3D views of the model can be displayed in 2D views:

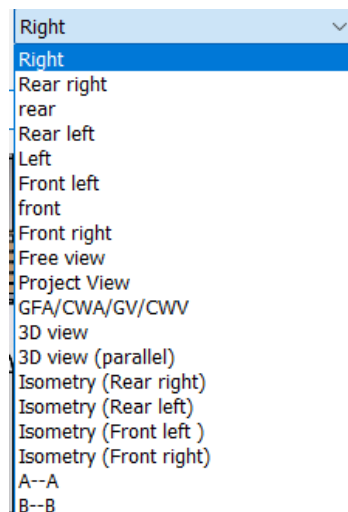

and the following display variants can be selected for these in turn:

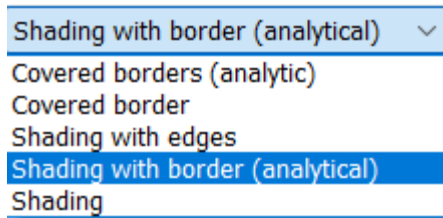

The advantages of displaying 3D content as a 2D view are:

- In the 2D view, the viewing point is always retained; it can be set to the section in 3D mode at

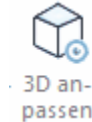

any time using the function **Adapt 2D view to 3D**.

- Lines can be hidden in the view (only with analytical hidden liner).
- The lines (only for analytical hidden liner) can also be displayed as a sketch
- The display can be supplemented with texts, dimensions and other 2D elements. Dimensions will only show the correct number of dimensions in plan and isometric views; in perspectives, the number of dimensions may need to be corrected by manual input.
- The colored display is generated with edge smoothing. If the 2D view with colored 3D representation is used in the plan layout as a project view, the quality is higher than with the project view of the 3D model.



## 15.10 Further settings

In the menu **2D views | Edit active 2D view...** menu, further parameters for the 2D view can be defined.

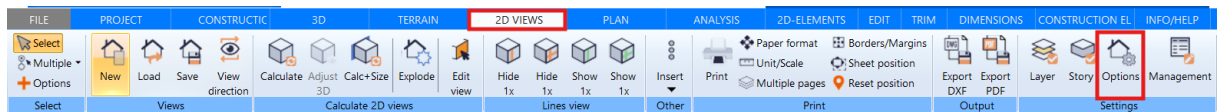

A distinction is made as to whether the view is

- a view (not resolved)
- a section (not resolved)
- or a "resolved" 2D view.

The following settings are available:

**Name:** Define a new name for your 2D view here if necessary. For "resolved" 2D views, this is the only parameter that can be changed.

Visible storey		Lines view	
Cross section		Cross section lines	
Designation	Scale	Display	Viewable Layer
Designation :	<input type="text" value="B--B"/>		
Category:	<input type="text"/>		

**Visible layers:** In this dialog, you can specify which layers of the construction mode should be shown in this 2D view. All layers of the model and not those of the 2D view are displayed in the list. In the **Visible layers** selection list, you can specify whether **all** layers, only the **active** layer or all **selected layers** are visible. The active layer is marked in the list in the **active** column (with the blue circle symbol). The active layer can be changed by clicking on the **active** column in the row of the desired layer in this list. With the **selected** setting, all layers that are **visibly** marked in the column are displayed (symbol with the eye). The default setting for new 2D views is **all layers visible**. This setting is only relevant for this 2D view.

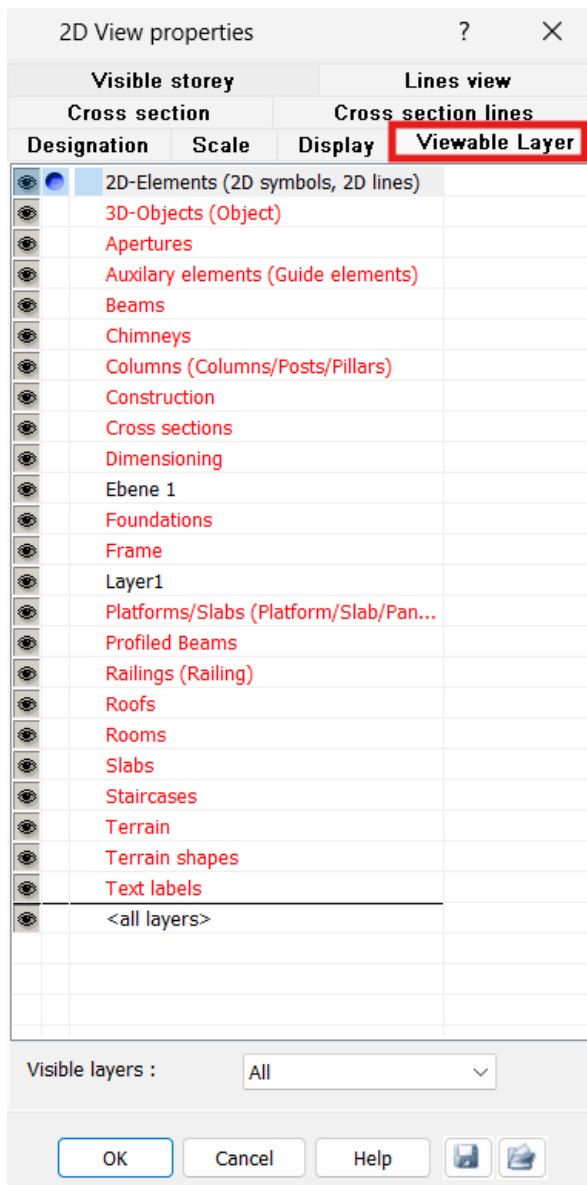

**Visible storeys:** This dialog is used to define which storeys of the model are visible in the view/section. In the **visible storeys** selection list, select whether **all**, only the **active** or all **selected storeys** should be visible. This setting is only relevant for this 2D view.

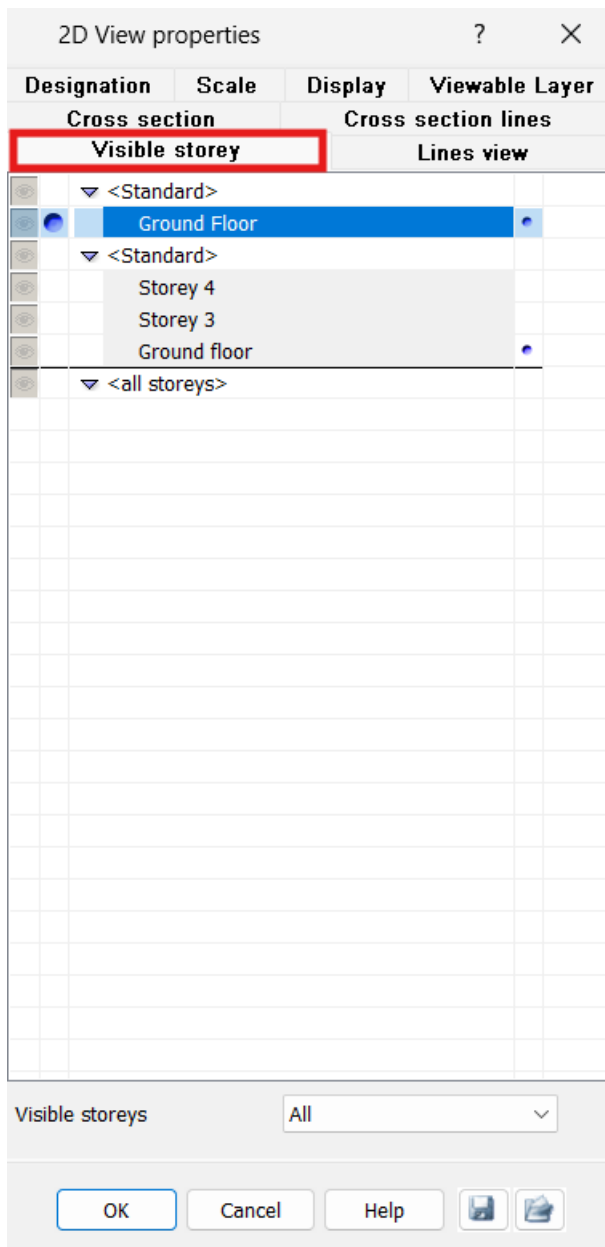

**Display:** The method for calculating the hidden edges can be set in the *Display* dialog.

There are five options:

- **Hidden edges (analytical)**  
The most accurate, but also the most time-consuming method of calculation (default setting)
- **Hidden edges**  
Provides fast results, but less accurate in detailed areas
- **Shading with edges**  
Calculates the hidden edges, but also shows the materials of the 3D representation in the background.  
This display requires a relatively large amount of computing power, so it is recommended that you select one of the other two display methods for processing the view and only switch to this variant for plan output. The lines cannot be hidden.
- **Shading with edges (analytical)**

As before, but with the most accurate calculation method for hidden lines. The lines can be hidden.

- **Shading**  
Only the materials of the 3D representation are shown.

**Save position of the sun**

Relevant for all views in which shadows are shown. If the option is activated, the position of the sun for the shadow calculation can be taken from the current 3D view, optionally also defined via the values v vertical angle and h horizontal angle.



When the view is recalculated, the position of the sun is used for the shadow calculation.

**Ignore transparency:** If this property is active, transparent surfaces (window glass) are not calculated as transparent. Edges of furnishings inside the building are not shown in the view.

**Show opening type:** Windows are displayed in the 2D views with the opening symbol.

**Quality:** Determines the size/quality of the colored background (of the bitmap) in the display variants **Shading with edges** and **Shading with edges (analytical)**

**Refresh:** The colored display is updated according to the setting.

- **Always:** every time the screen section is changed (slowly)
- **When updating:** when updating the 2D view 
- When updating **and printing:** when updating the 2D view  and before printing

**Other parameters:** Select whether north direction, contour lines, timber construction, cameras and light sources are displayed in the 2D view.

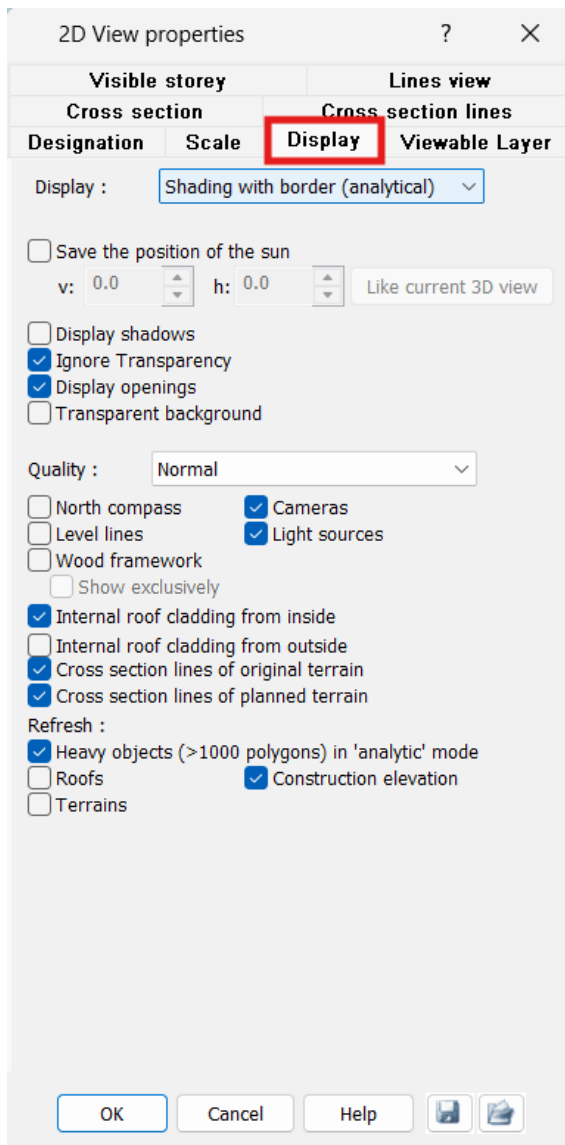

**View lines:** The parameters color, thickness, line type and line ends of the view lines are defined in this dialog. View lines are created by calculating the view/section for all areas of the model that are not sectioned (i.e. the entire display in views). 2D drawing elements subsequently added with the 2D functions are not affected by this setting.

**Section lines** (only available in sections): The display of all cut edges and surfaces. The representation of the cut edges and surfaces can be entered separately for each component type. The following can be selected in the selection list:

- **of type**  
The settings in this dialog are used for the respective component type. If you select this setting for floor construction, for example, all floor constructions of this section are displayed with the settings that were set directly for this component type in this dialog.
- **From element**  
The display in the section is taken from the 2D display. The settings for the component type in this dialog have no effect. If you use this setting for walls, for example, the display of the sectioned wall is taken from the settings in the floor plan.
- **Use standard**

In this dialog, a setting for cut edges and surfaces can be defined as the default in the list at the top. All elements without the option of setting their own parameters (such as stairs) and all elements with the use **default** property are displayed with these parameters.

**Important notes:** The parameters for floor slabs and ceiling slabs are listed separately. Floor slabs are the slabs automatically displayed when rooms are created. Ceilings slabs are entered separately by the user using the **Ceiling slabs** function in construction mode. Walls and wall layers can be provided with their own parameters in the sectional view. 2D drawing elements subsequently added with the 2D functions are not affected by this setting.

**Section:** In this properties dialog, the designation, the title of the section, the labeling of the section line and the viewing depth of the section can be defined.

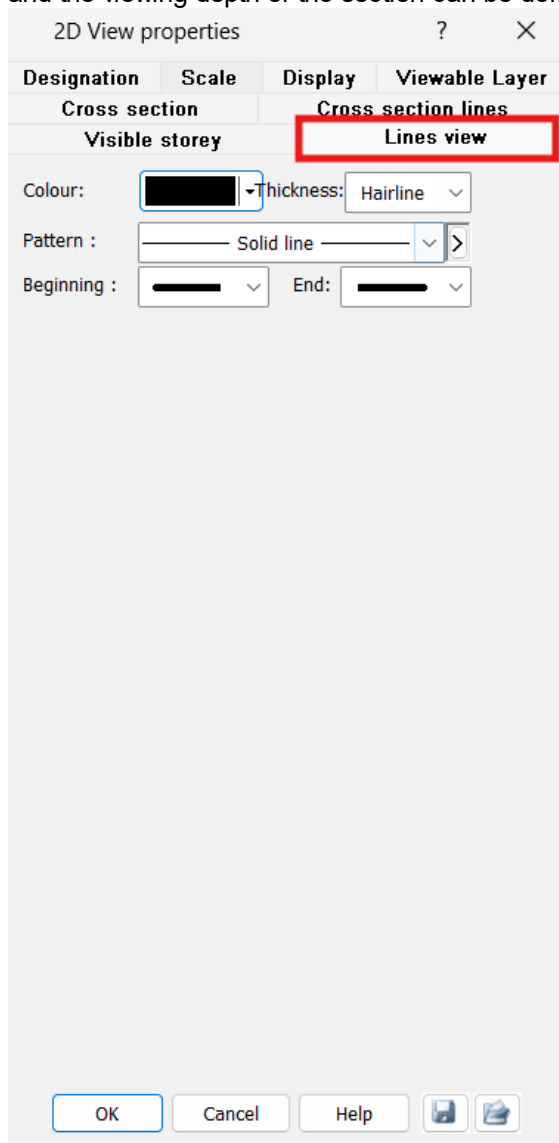

## 15.11 Working in 2D view mode

### 15.11.1 Hide lines

In 2D views, the display for the view and section is calculated from the 3D model. Edges that are covered by other elements are automatically hidden. However, if two elements meet at an edge, as shown in the illustration, this edge is visible.

#### Floor plan

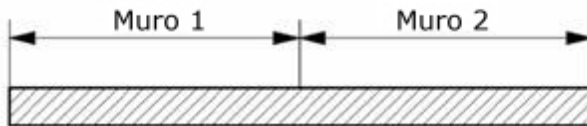

#### View

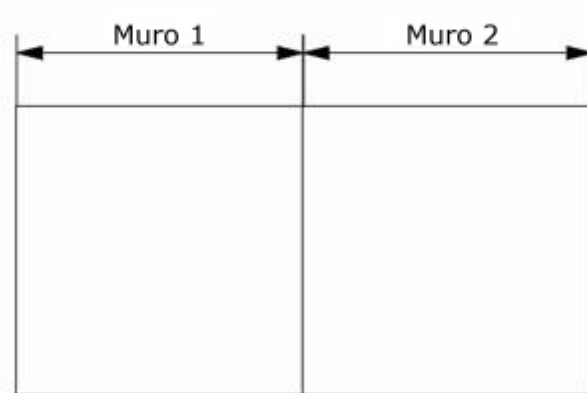

The following tools are available to hide edges:

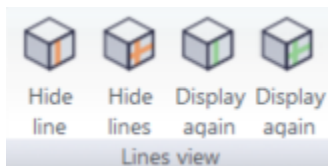

- **Hide line** (single)  
Select an edge of the view and it will be hidden. After updating, edges remain invisible as long as the position of this edge does not change. (If a wall becomes higher, the edge also becomes visible again).
- **Show lines** (individually)  
All lines that have already been hidden are initially highlighted in red. The line selected with a mouse click becomes visible again.
- **Hide view lines** (several via box)  
All edges within the defined rectangle (input via 2 diagonally opposite corner points) are hidden.
- **Display again** (several via box)  
All lines that have already been hidden are initially highlighted in red. The lines within the defined rectangle (input via 2 diagonally opposite corner points) become visible again.

### 15.11.2 Refresh

All connected, unresolved 2D views can be updated. This is necessary if the model has changed and these changes are to be reflected in the 2D view.

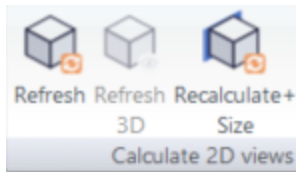

In **2D view** mode, click on **Calculate** in the drawing bar. Views of the floor plan are always updated automatically.

If a 3-D view, for example a perspective, is displayed in the 2-D view, you can use the **3-D Adjust** function to adopt the current viewing angle from the 3-D mode.

Calculate and size: The hidden lines are recalculated and the background image (if displayed) is resized to fit the current screen section.

### 15.11.3 Saving and loading

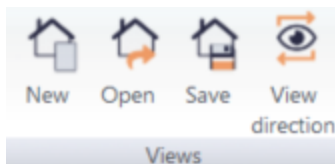

**New:**

A new 2D view is created. You can select the type of 2D view to be created in the dialog [Overview](#)<sup>1479</sup>.

**Load and Save:**

are commands for quickly transferring all elements and settings of a 2D view from one project to another.

Default settings for 2D views can also be made elegantly in this way.

**Load:**

A 2D view saved as a .view file is loaded into the project with all layers and all drawing elements. The type of 2D view and the desired viewing direction can be adjusted using the "Viewing direction" function.

**Save:**

The current 2D view is saved externally as a .view file. All settings, layers and drawing elements are contained in this file.

**Viewing direction:**

This command can be used to change the "Viewing direction" for a 2D view. You can select all directions as a view, all sections, but also other 2D view representations.

### 15.11.4 Visible layers and storeys

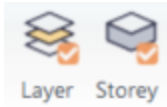

The user can define the [visible layers and storeys](#)<sup>4951</sup> for all connected, non-resolved 2D views. For views with analytical calculation, the visibility of the edges is recalculated.

### 15.11.5 Height dimensioning

In contrast to the height dimensioning in the floor plan, the triangle symbol is used in 2D views instead of the circle symbol. The height above zero is automatically calculated and updated if the dimensioning is moved.

If a 2D view is exploded, the height dimensioning can still be used; the reference to the zero height is retained after exploding. However, if you change the storey heights after exploding the view, the display can no longer be updated. In order to be able to work with the height dimensioning in a meaningful way, the drawing elements should be moved accordingly.

### 15.11.6 Export

A 2D view can be exported as an image file or as a vector file.

**Image file:** When exporting to an image file, exactly the current screen section is saved. Therefore, define the correct section and the visible layers before exporting. Select **File|Export|As image file...** from the menu.

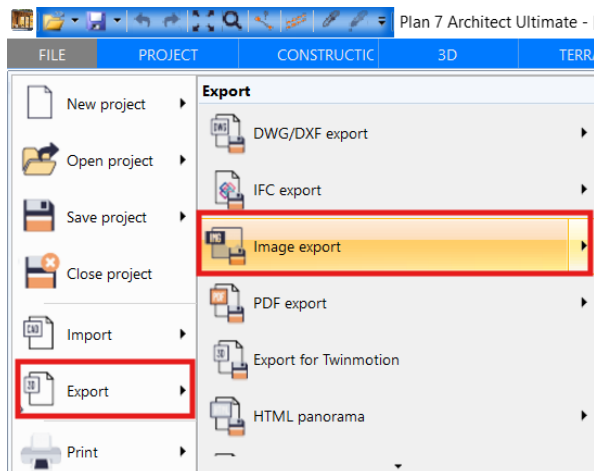

A window now appears in which you can specify the export options:

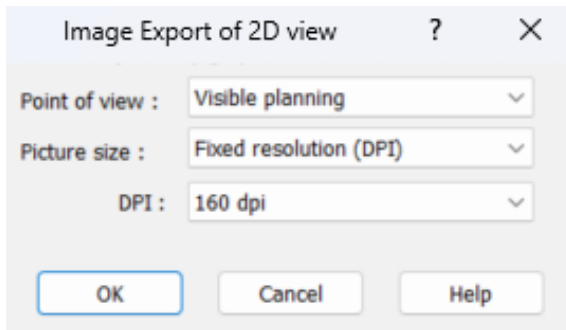

Specify the (image) **section** to be exported:

Visible planning  
Whole page  
Current point of view

visible planning:

Whole page

current point of view

Select the **image size**:

Fixed resolution (DPI)  
Fixed size

fixed resolution (DPI)

fixed size

If you select the **fixed size** option, you can now define the width and height of the section to be exported yourself:

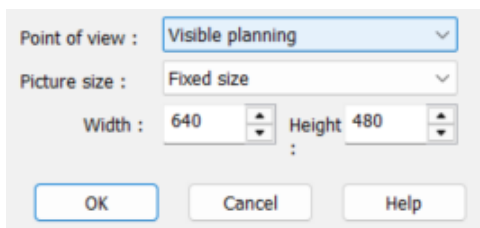

If you select the fixed resolution (DPI) option, you can now set the image quality in **DPI** (dots per inch):

<like screen>  
<like printer>  
72 dpi  
75 dpi  
96 dpi  
120 dpi  
150 dpi  
160 dpi  
180 dpi  
200 dpi  
300 dpi  
320 dpi  
360 dpi  
400 dpi  
500 dpi  
600 dpi  
Edit resolution...

By default, the resolution <as printer> is set here, select a predefined setting from the drop-down field:

<like screen> :

<like printer> :

If you want to define a resolution that is not in the list, click on :

**Other resolution...**

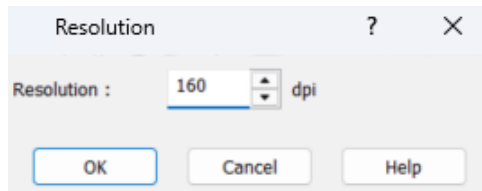

and enter the desired resolution here.

Once you have selected a resolution from the list, confirm with **OK** and the **Save as** dialog opens. Select the storage directory, the file name and the file format and click on **Save**.

The following file formats are available:

- WMF
- EMF
- BMP**
- JPEG
- GIF
- TIFF
- PNG

**Vector file:** DXF and DWG files can be exported. Under menu bar **File|Export|As DXF/DWG...** Please note that when exporting a 2D view, only the visible layers are exported.

## 15.12 Scale, paper format and printing

The scale and paper format are defined for the view at the start and can be changed at any time in the **View** menu. These settings only ever affect the current 2D view.

Select **View|Show borders** from the menu. The margins of the set plan format are displayed.

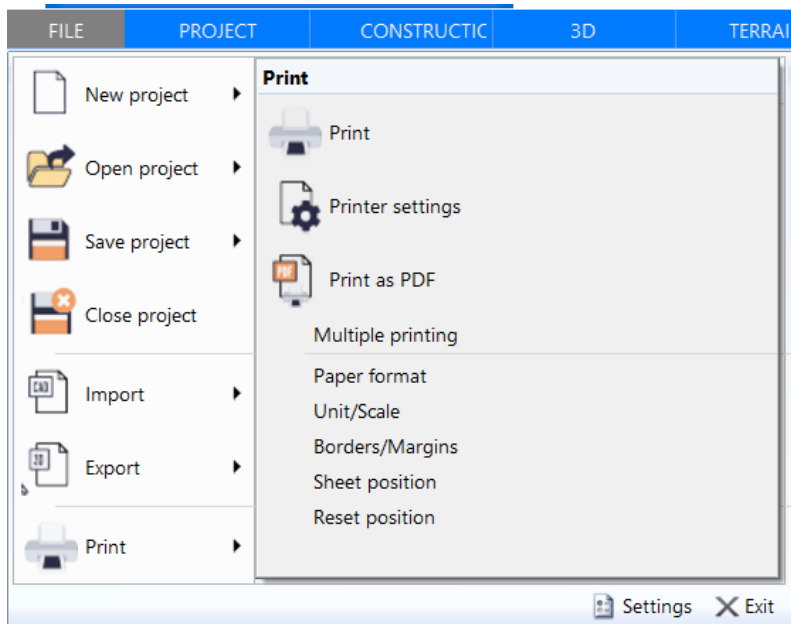

The position of the plan format in relation to the drawing can be defined with **View|Position sheet**. The reference point can be varied as usual using the **W button**.

The **Multiple pages** setting shows how the printout of a plan is divided if the plan format is larger than the paper format of your printer/plotter.

## 15.13 Tips and tricks

### In section: Ceilings up to the outer edge of the wall

Storey ceilings are drawn in sections up to the outer edge of the core area of the wall. If the ceiling is only to be drawn up to the outer edge of the load-bearing masonry and the full thermal insulation is to go through to the upper edge of the ceiling, the full thermal insulation must be outside the core area in the wall settings.

### Quick hidden line calculation - deactivate layer

The calculation effort required to create or update a 2D view with hidden hidden edges increases disproportionately to the bodies contained in the scene. It is therefore recommended to deactivate those layers that only contain invisible objects before the first calculation.

Example: All interior fittings are invisible when calculating an exterior view, so the layer can easily be hidden without affecting the result.

## 15.14 Sketch

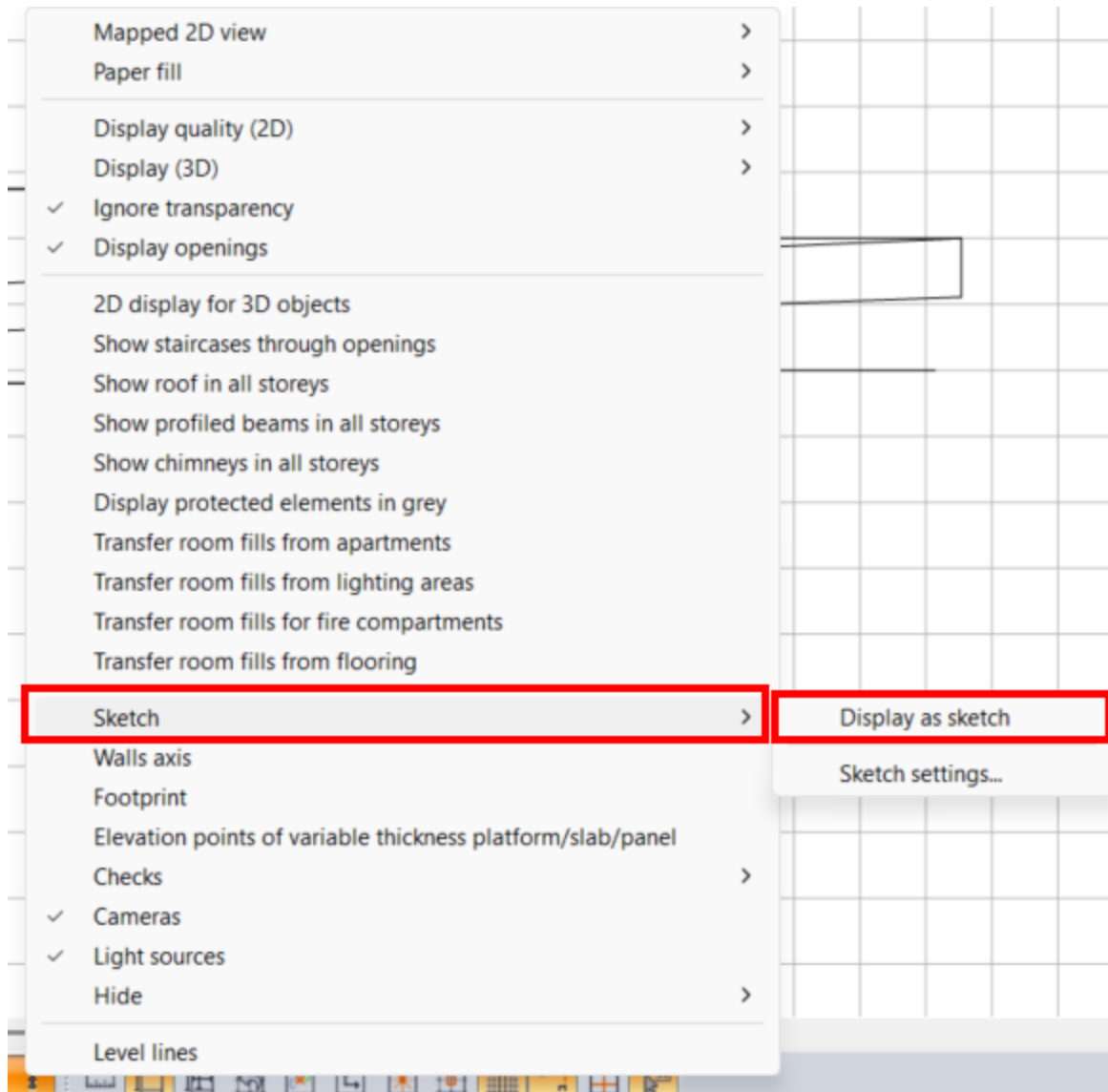

Floor plans and 2D views can be displayed as sketches. All edges of the drawing are blurred according to the **sketch settings**, giving the impression of a freehand drawing. Dimension lines, arcs and circles are currently not blurred. Please note that texts are not displayed in a different way. Use a freehand font if necessary.

### **Sketch settings:**

The following sketch parameters can be influenced separately for lines and hatching:

#### **Use**

Only applies to hatching. Deactivate this option to hide hatching in the sketch display.

#### **Blur**

Lines or hatchings are displayed blurred.

**Average amplitude**

How much the blurred line deviates from the straight line.

The values are entered in cm on the printout, so the result depends on the scale.

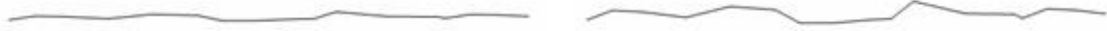

small amplitude (0.5 cm) large amplitude (1.0 cm)

**Period length**

Small period length (1.0 cm) Large period length (3.0 cm)

**Average extension**

The freehand lines are extended at the corners. To give a realistic impression, this extension varies according to a random generator.

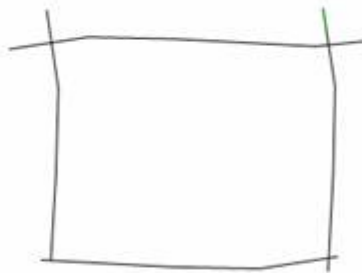

A rectangle of four lines. The end points lie exactly on top of each other. The extension is generated by the sketch display.

**Color and line thickness**

Optionally, all lines can be shown in a selected color and thickness for the sketch display.

**Note:** The usual architectural representation of "overdrawn corners" with otherwise straight lines is achieved by setting the value for the amplitude to  $0$  and therefore only the corresponding value for the **middle extension** is relevant.

## 15.15 2D views management

Projects often have a large number of 2D views. To maintain a quick overview, make changes quickly or select a 2D view, there is the **2D view Manager**. In **2D views** mode, click

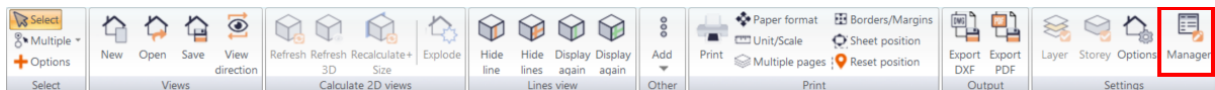

mode, click on the **management** button

The 2D view management window now opens:

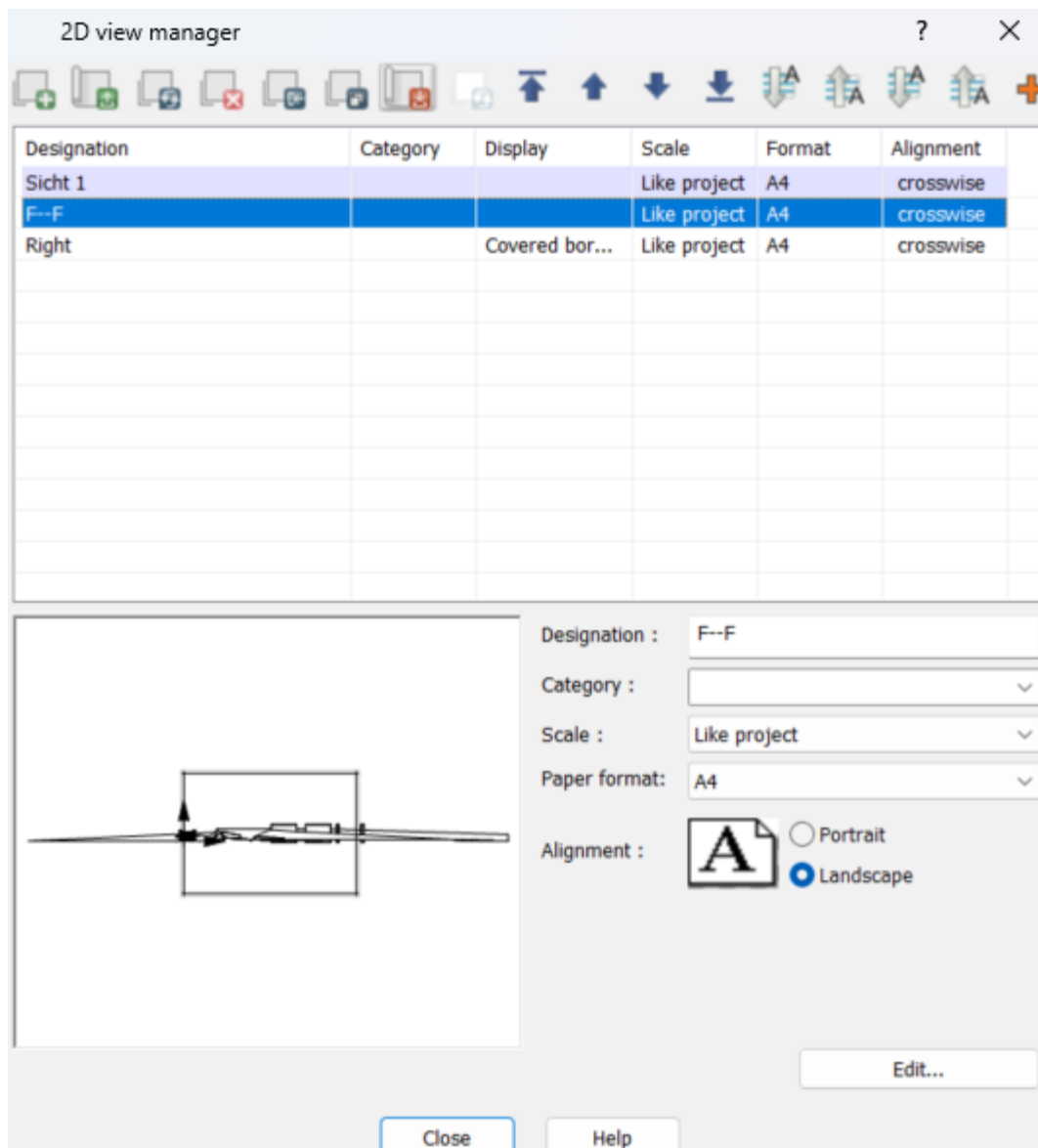

### 15.15.1 View management settings

Various settings can be made in the view management:

Upper command bar:



- 1: Create new 2D view
- 2: Load view
- 3: Recalculate all
- 4: Delete 2D View
- 5: Open View
- 6: Duplicate View

- 7: Save View
- 8: At the beginning
- 9: Page up (highlighted view)
- 10: Page down (highlighted view)
- 11: At the end (highlighted view)
- 12: Sort (name) ascending
- 13: Sort (name) descending
- 14: Sort (category) ascending
- 15: Sort (category) descending
- 16: Category display filter

View management - overview:

Designation	Category	Display	Scale	Format	Alignment
Sicht 1			Like project	A4	crosswise
F--F			Like project	A4	crosswise
Right		Covered bor...	Like project	A4	crosswise

Editing options for each selected view in the overview:

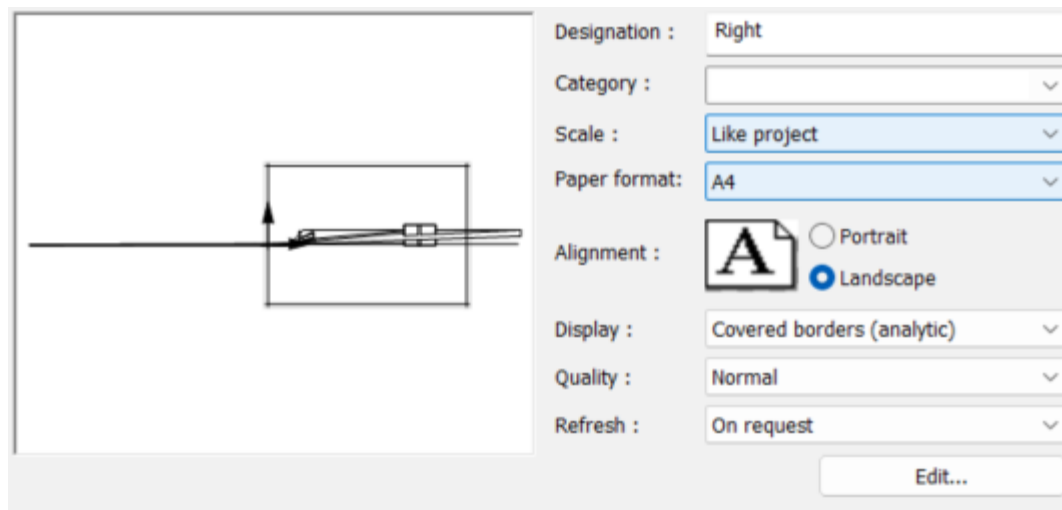

**Name:** Enter any name for the view here.

**Category:** Free field, can be sorted by category

**Scale:** Use the same scale as for the project, select a scale from the list or define your own scale using the **1:x ...** option .option to define your own scale:

Like project  
 1 : 100  
 1 : 50  
 1 : 20  
 1 : 10  
 1 : x ...

**Paper format:** Select the desired paper format

**Orientation:** Choose between portrait and landscape format

**Display:** Choose between several display options

Covered borders (analytic)  
covered border  
Shading with borders  
Shading with border (analytical)  
Shading

**Quality:** Select the quality of the 2D view (the higher the quality, the longer the calculation takes!) The "High" option is recommended as a compromise between quality and computing capacity.

Very high  
Tall  
Normal  
Low  
Very low

**Refresh:** Select here when the update of changes in the 2D view should take place

always  
On request  
On request or when printing

Finally, always click on the **Apply** button to apply the changes you have made.

Clicking on the **Edit..** button opens an additional **2D view properties** menu:

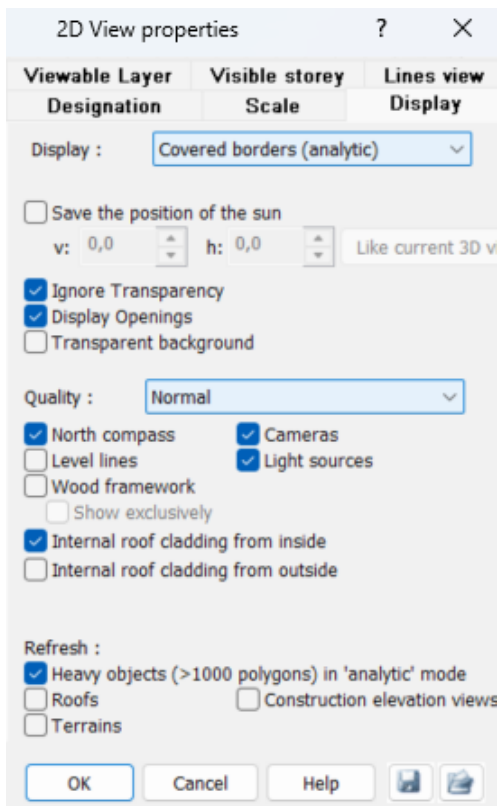

Additional settings and formatting of the 2D view can be made in the Display tab.

**Options:**

Ignore transparency  
Display opening type

Display of:

North direction  
contour lines  
Wooden construction / exclusive  
Cameras  
Light sources

Interior roof cladding from inside / outside

Section lines original terrain / projected terrain

Hide the following component types:

Roofs  
terrain  
Construction levels

By clicking on the **Save** button  , the settings made here can be saved (as a .gvp file) or an already saved settings file can be loaded by clicking on the Open button and applied to the current 2D view.

settings file can be loaded by clicking on the **Open** button  and applied to the current 2D view.

## 16 2D elements

### 16.1 General information

A distinction is made between the following **2D elements**:

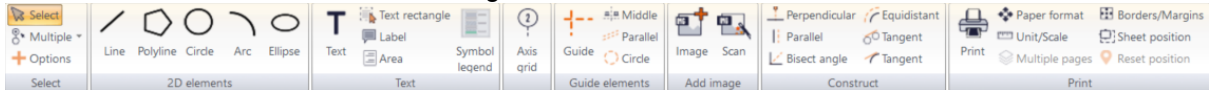

- Graphic elements such as line, polygon, circle
- texts
- Axis grid
- Auxiliary elements such as auxiliary lines and auxiliary circles
- images

**2D elements** are used for construction and not for visualization. In contrast to the components, 2D elements are not used in 3D mode. 2D elements support you in placing the components (design aids), supplement the plan with details or allow you to add further information (dimensions, text) to your plan in addition to displaying the components.

All elements can be assigned to layers. Dimensioning and auxiliary elements are automatically assigned to their own layer, the others to the current layer.

2D elements can be entered in the **construction**, **terrain**, **2D views** and **plans** modes.

### 16.2 Lines

Lines are placed on the current layer.

Click on the **lines** button  in the **construction bar**

**+** Possible input options:



**Horizontal/vertical only** - only horizontal and vertical lines can be drawn

**Offset** - the line is constructed parallel to the input points with offset.

Before drawing lines, select the desired input [type](#)<sup>[520]</sup> and [properties](#)<sup>[522]</sup>.

#### 16.2.1 Input types

- **Any line**



Required input: 2 points

The line is entered using the start and end points.

In the Construct section you will find

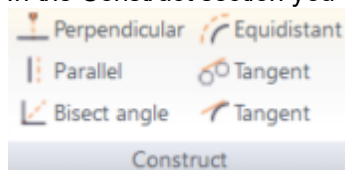

- **Angle bisector**

Required input: 2 directions, 2 points

First, the two directions are snapped in order to construct the angle bisector. To do this, click on the two reference edges. Once both directions have been determined, the angle bisector is displayed. The start and end points must now be entered. These points can only lie on the angle bisector.

- **Drop perpendicular**

Required input: 1 direction, 1 point

Select the edge to which the perpendicular is to be dropped. Then enter the end point of the perpendicular line. The starting point is always on the edge.

- **Parallel line**

Required input: 1 selection line, 1 point for the side, 2 points

A line is drawn parallel to an existing line or edge. The start and end points are placed freely on this parallel line.

First a line is selected to determine the direction. Then a point is determined with the mouse, which determines the starting element in relation to the side.

If the **Ask value** option is not active, this point

- this point also determines the distance, otherwise
- you will be asked for the distance. Enter the desired value and confirm with **OK**.

Finally, the start and end points are placed on the straight line.



Possible input options:

**Fixed distance** - the parallel line is created with a fixed distance.

**Ask for value** - the value for the distance is asked for each entry.

- **Parallel to a line**

Required input: 1 selection line, 1 point

First select the line to which a parallel line of the same length is to be drawn. The next point determines the position and the distance to the starting line.

If the **fixed distance** option is selected, the second point only determines the position, but not the distance.



Possible input options: **Fixed distance** - the parallel line is created with a fixed distance.

- **Tangent to two circles/ellipses/arcs**

Required input: 2 selection

Select two circles or arcs. The tangent is constructed.

- **Tangent to circle/ellipse/arc**

Required input: 1 selection, 1 point

Select a circle or arc. The end point of the tangent can now be drawn.

## 16.2.2 Property dialogs

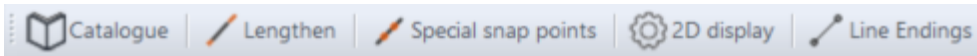

### Catalog

Lines that are used frequently are stored in the catalog. Further information on [catalogs](#)<sup>[150]</sup> can be found in the **General properties dialogs** chapter.

### Extend

The [Extend](#)<sup>[142]</sup> properties dialog is described in the General **properties dialogs** chapter.

### Special snap points

The Special [snap](#)<sup>[143]</sup> points properties dialog is described in the General **properties dialogs** chapter.

### Contour

The [Contour](#)<sup>[138]</sup> properties dialog is described in the General **properties dialogs** chapter.

### Line ends

The [Line](#)<sup>[142]</sup> ends properties dialog is described in the General **properties dialogs** chapter.

### Layer/floor

The [Layer/Floor](#)<sup>[143]</sup> properties dialog is described in the General **properties dialogs** chapter.

### Size/Position

The [Size/Position](#)<sup>[143]</sup> properties dialog is described in the General **properties dialogs** chapter.

## 16.3 Polygon

Contours are stored on the current layer.  
Click on the Polygon button.



**+** Possible input options:

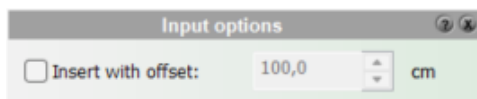

**Enter with offset** - the contour is constructed parallel to the input points with offset

Before drawing contours, select the desired input [type](#)<sup>[523]</sup> and [properties](#)<sup>[524]</sup>.

**Draw polygons with arcs**

During input, you can use these buttons to define how the next segment of the polygon is to be drawn.

1st line

The next segment is a line

2. tangent

The next segment is a tangent to the previously drawn arc

3. tangential arc

The next segment is a tangential arc to the previously drawn segment (line or arc)

4. 3-point arc

The next segment is an arc drawn by entering 3 points



### 16.3.1 Input types

- ✎
**Polygon course**  
 Required input: n points  
 The polygon is entered using any number of corner points. End the input by selecting **[Esc]** or via the context menu **Finish element**.  
 If the first point is entered again as the last point, the polygon is closed. The polygon can also be closed by selecting **Close contour** via the  button or in the **Contour** properties dialog - even retrospectively.

The type of the next segment can be specified during input using the buttons



- ✎
**Polygon with fixed width**

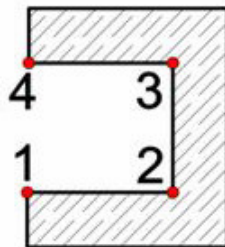

Required input: n points

The polygon is entered using any number of corner points. The result is a "band" of the set width with a closed contour. End the input by selecting **[Esc]** or via the context menu **Finish element**.





Possible input options:

**Offset** - the contour is constructed parallel to the input points with offset.

**Width** - the width of the polygon.

- **Rectangle** 

Required input: 2 points  
The polygon is entered via two opposite corner points (diagonals).
- **Rotated rectangle** 

Required input: 3 points  
First define one side of the rectangle with two points. The height of the rectangle is defined with the third point.
- **General spline** 

Required input: n points  
The polygon is drawn as a spline with any number of corner points. End the input by selecting **[Esc]** or via the context menu **Finish element**.
- **Freehand line** 

Hold down the left mouse button and trace the contour of the polygon.

✚ Possible input options: **Shake correction** - the polygon is smoothed in the specified pixel range after the input .
- **N-corner** 

Required input: 3 points  
The number of corner points is set in the **N-corner** properties dialog.  
First place the center point of the polygon and specify the radius (corner point) with the 2nd point. Use the 3rd point to place a corner point exactly where you want it, so you can still rotate the N-corner around the center point.

A quick swap from **polygon** course to **rotated rectangle** is now possible:

Polygon course is selected, the first two points are set. If the third point is set normally, the input remains polygonal. If the CTRL key is also pressed when setting the third point, the input changes to rotated rectangle.

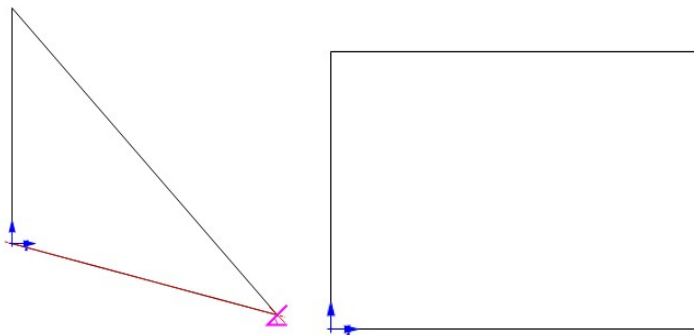

- **Bezier curve** 

Required input: 4 points

### 16.3.2 Property dialogs

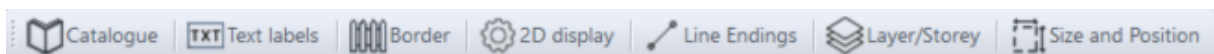

#### Catalog

Contours that are used frequently are stored in the catalog. Further information on [catalogs](#)<sup>[150]</sup> can be found in the **General properties dialogs** chapter.

Labeling

Outline

2D representation

### Contour

The [Contour](#)<sup>[138]</sup> properties dialog is described in the General **properties dialogs** chapter.

### Close contour

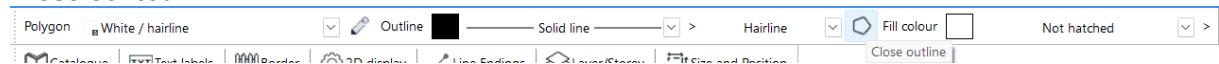

Fills and hatching are only shown when polygons are closed.

### Fill

The [Fill](#)<sup>[140]</sup> properties dialog is described in the General **properties dialogs** chapter.

### Hatching

The [Hatching](#)<sup>[141]</sup> properties dialog is described in the General **properties dialogs** chapter.

### Line ends

The [Line](#)<sup>[142]</sup> endsproperties dialog is described in the General **properties dialogs** chapter.

### Layer/floor

The [Layer/Floor](#)<sup>[143]</sup> properties dialog is described in the General **properties dialogs** chapter.

### Size/Position

The [Size/Position](#)<sup>[143]</sup> properties dialog is described in the General **properties dialogs** chapter.

## 16.3.3 Edit

The commands for insert point, delete point and extrude are described here:

[Contour tools](#)<sup>[548]</sup>

[Edit contours](#)<sup>[548]</sup>

[Extrude contour](#)<sup>[548]</sup>

In addition to polygons, these commands also apply to ceilings, slabs and foundation slabs.

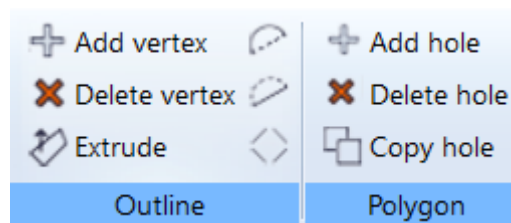

### Edge - Arc and Arc - Edge

These commands are used to subsequently change a polygon segment from line to arc or from arc to line.

**Convert**

Converts a polygon into lines and arcs

**Trimming**

The following trimming commands can be applied to the polygon:

[Break up \(A\)](#) 

[Chamfer](#) 

[Round off](#) 

**16.3.4 Holes**

Holes can also be cut into polygons.

Hatchings and fillings are omitted in the process

The area of the polygon is specified minus the openings.

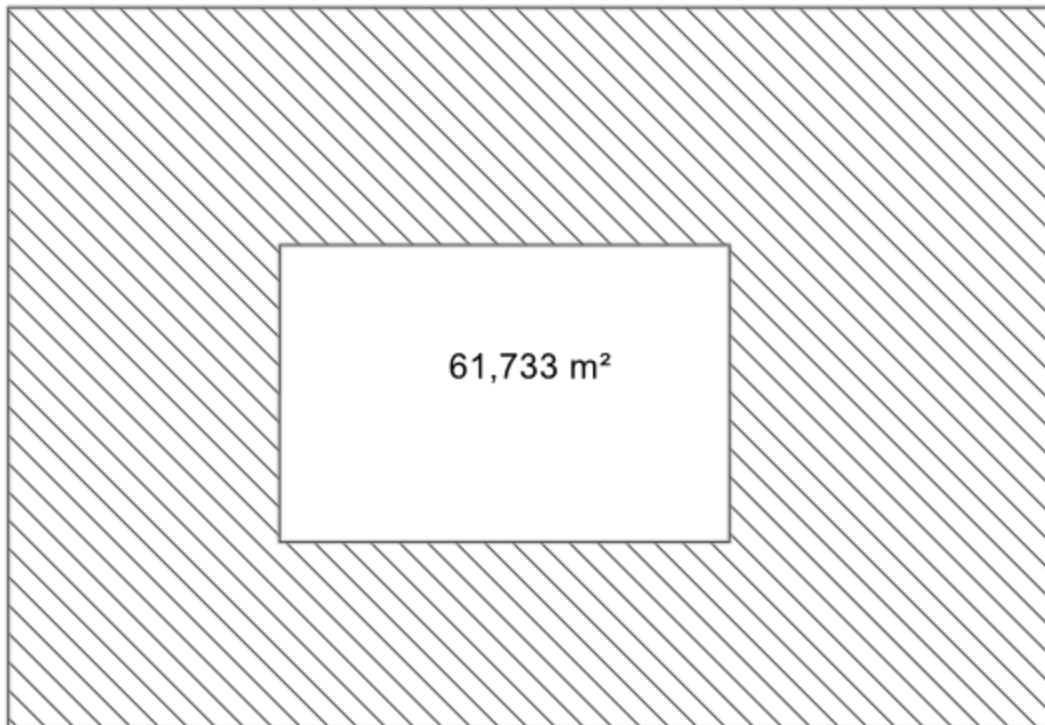

The commands for polygon holes:

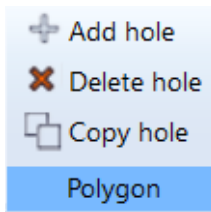
**Assign a hole:**

Draw a polygon and the hole as a polygon as well  
 Select the Add hole command, select the polygon and then the hole polygon

**Remove hole:**

Select the Remove hole command and then the hole polygon

**Copy hole:**

Select the Copy hole command and then the hole polygon.  
 The hole polygon is retained. A new polygon with the outline of the hole polygon is created.

**Edit holes:**

If you move the mouse pointer over the polygon, the handles of the polygon and the hole polygons are displayed.

A hole polygon can be edited like a polygon itself. Points and edges can be moved, inserted and deleted.



## 16.4 Circles and arcs

Click on the *Circles/Circular arcs/Ellipses/Special curves* button.

### 16.4.1 Input types

Select the desired input type before drawing:

#### 16.4.1.1 Arcs

- **Arc through three points**   
 Required input: 3 points  
 First enter the start and end points, then any point on the arc.
- **Clockwise arc**   
 Required input: 4 points  
 The input sequence is center point, point on the arc (radius), start point and end point.
- **Counterclockwise arc**   
 Analog *clockwise* arc

### 16.4.1.2 Circles

- **Circle over center and radius** 

Required input: 2 points  
The first input point defines the center point, the second a point on the circle (radius).
- **Circle through two opposite points** 

Required input: 2 points  
Define 2 opposite points on the circle (diameter).
- **Circle through three points** 

Required input: 3 points  
Define the circle by placing 3 points on the circle.

### 16.4.1.3 Ellipses

- **Clockwise elliptical arc** 

Required input: 4 points
- **Counter clockwise elliptical arc** 

Required input: 4 points
- **Ellipse defined by two axes** 

Required input: 3 points
- **Ellipse** 

Required input: 2 points  
Ellipse over center point and point on circumscribing rectangle
- **Ellipse through circumscribing rectangle** 

Required input: 2 points

## 16.4.2 Property dialogs



### Catalog

Circles and arcs that are used frequently are stored in the catalog. Further information on [catalogs](#)<sup>1501</sup> can be found in the **General properties dialogs** chapter.

### Contour

The [Contour](#)<sup>1381</sup> properties dialog is described in the General **properties dialogs** chapter.

### Close contour



Fills and hatches are only shown for closed polygons.

### Fill

The [Fill](#)<sup>1401</sup> properties dialog is described in the General **properties dialogs** chapter.

### Hatching

The [Hatching](#)<sup>[141]</sup> properties dialog is described in the General *properties* dialogs chapter.

### Layer/floor

The [Layer/Floor](#)<sup>[143]</sup> properties dialog is described in the General *properties* dialogs chapter.

### Size/Position

The [Size/Position](#)<sup>[143]</sup> properties dialog is described in the General *properties* dialogs chapter.

### Arc

Circular and elliptical arcs can be subsequently edited using the **Arc** properties dialog. The radius, start angle and arc angle can be changed.

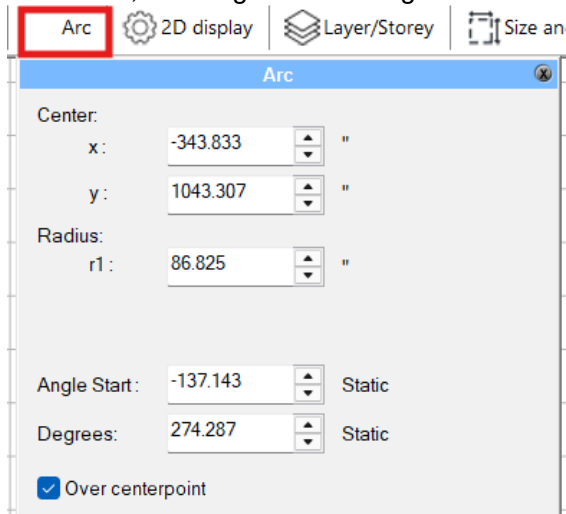

## 16.5 Texts

Select the desired function from the selection list of input types:

- [Text rectangle](#)<sup>[531]</sup>
- [Area composition](#)<sup>[532]</sup>
- [Label](#)<sup>[534]</sup>
- [Text input](#)<sup>[530]</sup>

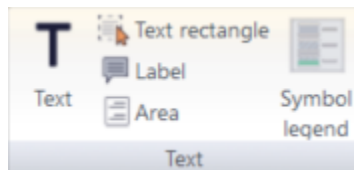

Texts that are used frequently are stored in the catalog. Further information on [catalogs](#)<sup>[150]</sup> can be found in the [General properties dialogs](#)<sup>[134]</sup> chapter.

### 16.5.1 Text input

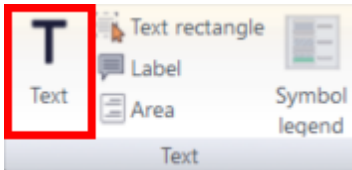

First, the position of the text is defined in the planning with a mouse click. The **Text** dialog opens.

Enter the desired text in the input field.

For formatting multi-line texts, you can select **right-aligned**, **centered** or **left-aligned**.  
Special characters can be easily selected using the



button.

The font size can be entered in **mm** or **points (pt)**.  
The font size is the size of the text on the paper.  
If the **Ignore scale** option is active, the font size is absolute, i.e. independent of the printed scale.

The rotation angle of the text can be defined before it is set.

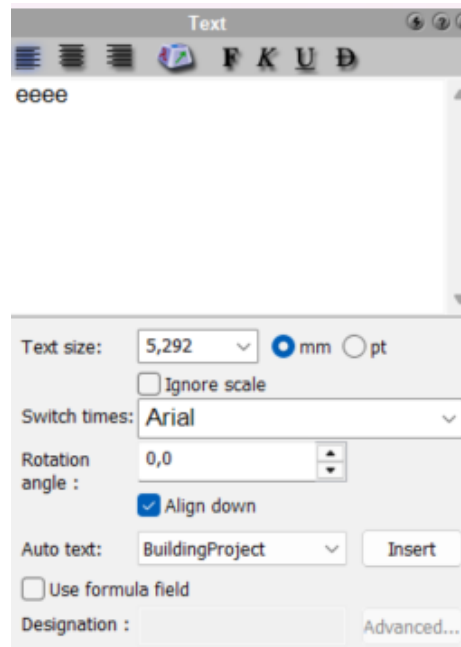

#### Alignment with descenders:

This option was not available in previous versions. The default setting for this option is therefore "Not active"

Texts written with older versions do not change their position.

If this option is activated, the height of the text is aligned to a baseline, regardless of whether characters with descenders or ascenders are present. (e.g. y or Ä)

ABC ABC y,Ä

The baseline is the insertion point of the text. If this option is activated, several texts are now aligned nearly in one line.

Without this option, it would look something like this:

The alignment is not along a line, but solely by the size of the text.

This option is particularly useful for plan headers, as the content no longer changes the position of the text.

**Autotext:** Project data can be used in texts. Select the desired entry from the selection list and click on **Insert**. The autotext is inserted into the text as **\$Project data\$** and evaluated in the planning. If you change project data, all autotexts are corrected.

**Use as form field:** Texts can be changed within groups without having to dissolve the group first. For this purpose, a name can be assigned to make a text easier to recognize. This name is entered by activating the Form field option for the text and entering the associated name (possibly also a prompt). If this text is grouped with other elements, the corresponding text appears next to the name (or prompt) in the Texts dialog of the group.

 Possible input options:

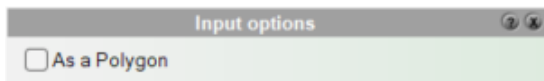

**As polygon:** the text is inserted into the planning as a polygon. This can be used, for example, to subsequently extrude the text. Please note that as soon as this option is active, the text is no longer recognized as text and can no longer be changed as text.

## 16.5.2 Text rectangle



With this type of text input, a rectangle is first defined in the planning using 2 diagonally overlapping corner points, into which the text is then written.

During input, a "Text" button appears , clicking on this button opens a menu with text formatting options:

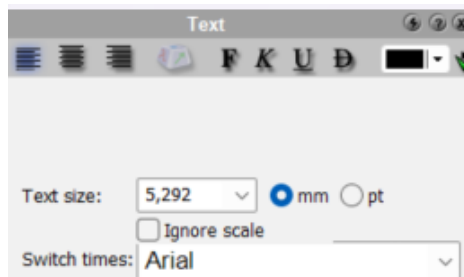

### 16.5.3 Area composition



<b>USABLE AREA BUILDING</b>	
<b>Ground floor</b>	
Room 1	495.04 ft <sup>2</sup>
Room 2	182.88 ft <sup>2</sup>
Room 3	336.88 ft <sup>2</sup>
Room 4	21.78 ft <sup>2</sup>
<b>Sum Ground floor</b>	<b>1036.57 ft<sup>2</sup></b>
<b>Storey 3</b>	
Room 1	495.04 ft <sup>2</sup>
Room 2	182.88 ft <sup>2</sup>
Room 3	336.88 ft <sup>2</sup>
Room 4	21.78 ft <sup>2</sup>
<b>Sum Storey 3</b>	<b>1036.57 ft<sup>2</sup></b>
<b>Sum &lt;Standard&gt;</b>	<b>2073.15 ft<sup>2</sup></b>

An area summary is an automatically generated list of all buildings, storeys and rooms with their areas or volumes.

The areas to be evaluated (living space, floor area, etc.) can be freely selected. For storeys and buildings, the sum of all rooms contained is calculated.

Thanks to the extensive parameters, detailed lists or just a total sum can be displayed.

Area combinations can be used in construction mode, in 2D views and also in plans. In views and plans, it is also necessary to specify the reference storey, which is predefined in construction mode.

The composition is updated automatically whenever changes are made to the model. As with all elements in the catalog, the settings can be saved as a template for easy reuse.

#### 16.5.3.1 The parameters in the Area composition dialog

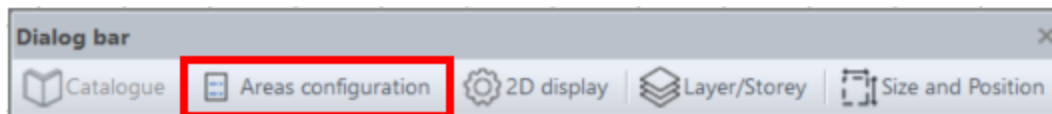

**Reference storey:** This selection is only available when using the *Plans* or *2D views* modes. Select the storey to be evaluated in the compilation here.

**Show:** First select whether the compilation should list all rooms of the storey, the building or the entire project. Then use the selection list to the right to determine which mass (area type or volume) is to be displayed.

**Usable area type/enclosure type:** The usable area type and the enclosure according to DIN can be defined for each room in the Room data dialog. These two selection lists can now be used to select which rooms are to be included in the compilation according to this data.

**Sort rooms :** How are the rooms sorted in the list? Select whether the sorting should be by name (the room name in alphabetical order), by value (e.g. by area, in descending order) or by room number.

**Display room number :** If you have entered a room number for the rooms in your project in the *Room data* dialog, this option can also be used to display it in the area summary.

**Room zone:** Select a zone here to display only the rooms contained in this zone. The zone can be assigned for a room in the *Room data* dialog.

**Border:** This parameter defines the distance between the text of the listing and the border. This setting is naturally important when using a visible contour or a fill.

**Show title :** This text is shown as the heading. Please note that the font for this text can be set individually.

**Show headers/footers:** Free text after the heading or at the end of the compilation with freely adjustable font.

### Display matrix

	Superscript	Schedule	Divider	Sum
Project :	<input type="checkbox"/> A	<input checked="" type="checkbox"/> Buildings	<input type="checkbox"/> A	<input checked="" type="checkbox"/> A
Building :	<input type="checkbox"/> A	<input checked="" type="checkbox"/> Storeys	<input checked="" type="checkbox"/> A	<input checked="" type="checkbox"/> A
Geschoss :	<input checked="" type="checkbox"/> A	<input checked="" type="checkbox"/> Rooms	<input checked="" type="checkbox"/> A	<input checked="" type="checkbox"/> A

Please note that the lines that correspond to the selection under **Display** at the top of the dialog are activated. This matrix is used to set which parts of the compilation are visible. You can choose from:

- **Heading:** shows the name of the respective element. If no total is displayed, the result is displayed in this line.
- **Listing:** The subordinate elements contained in this element (e.g. all floors of the building in buildings) are displayed individually.
- **Dividing line:** A dividing line is inserted after the element.
- **Sum:** A sum is displayed as the last line.

#### 16.5.3.2 Further property dialogs

All settings in the [Layer/storey](#)<sup>[143]</sup>, [Size/position](#)<sup>[143]</sup>, [Contour](#)<sup>[138]</sup>, [Fill](#)<sup>[140]</sup>, [Hatch](#)<sup>[141]</sup> and [Catalog](#)<sup>[349]</sup> dialogs are explained in the [General properties dialogs](#)<sup>[134]</sup> chapter.

#### 16.5.4 Labels

**Labels** are the new text variant for **placing texts with lines, arrows, circles, frames...**

The command can be found under **Texts**



Various settings are possible in the Label container:

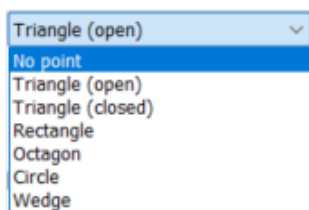
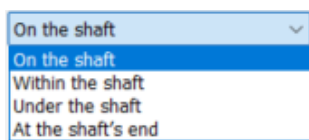
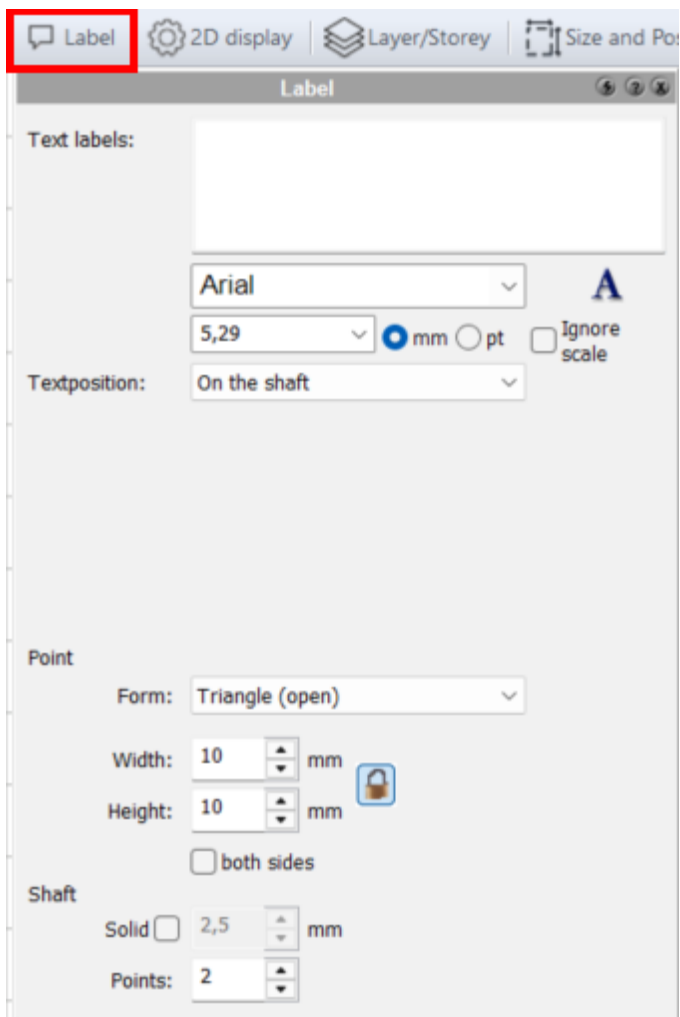

Examples of labels:

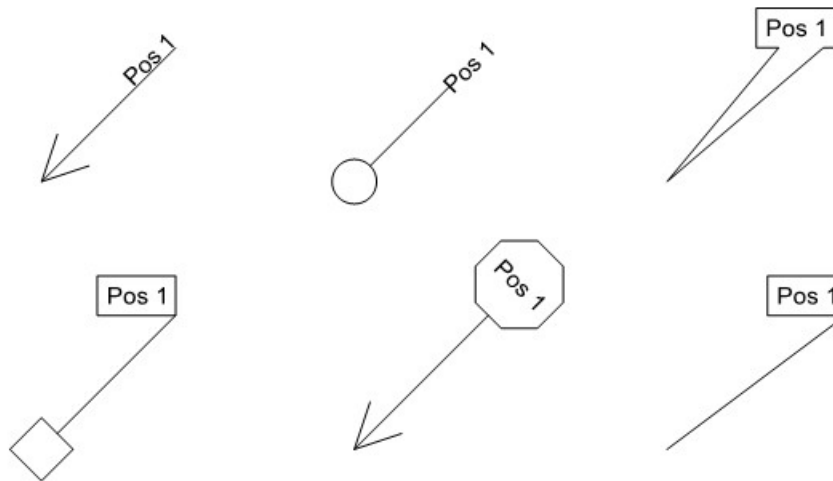

## 16.6 Auxiliary elements

Auxiliary elements are stored on the **Auxiliary elements** layer, but can be assigned to another layer at any time in the **Layer/floor** properties dialog.

You will find the auxiliary elements in the 2-D elements section

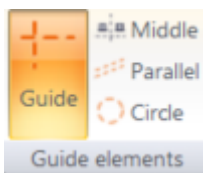

**+** Possible input options:

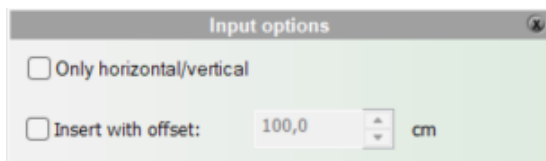

**horizontal/vertical only** - only horizontal and vertical lines can be drawn



**enter with offset** - the auxiliary element is constructed parallel to the input points with offset.

Before drawing auxiliary elements, select the desired input [type](#)<sup>[536]</sup> and [properties](#)<sup>[537]</sup>.

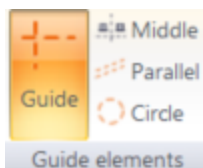
### 16.6.1 Input types



- **Any auxiliary line**  
Required input: 2 points  
The auxiliary line is entered via the start and end points.

- **Parallel auxiliary line**  
 Required input: 1 selection line, 1 point  
 First select the line to which a parallel line of the same length is to be drawn. If the **Ask for distance** option is active, you will now be asked for the distance. If you press **[Esc]**, the distance of the auxiliary line can be freely selected with the mouse.  
 If the **fixed distance** option is selected, the second point only determines the position, but not the distance.  
 Possible input options:  
**Fixed distance** - the parallel line is created with a fixed distance.  
**Ask for distance** - the value is asked for each input.
- **Centered line**  
 Required input: 2 points  
 You click on two input points between which the auxiliary line is created perpendicular to them at a specific division ratio.  
 You can specify the value for the division ratio in the **input options**.  
 Possible input options: **Division ratio**
- **Circle over center point and radius**  
 Required input: 2 points  
 The auxiliary circle is constructed using the center point and any other point of the circle.

## 16.6.2 Property dialogs

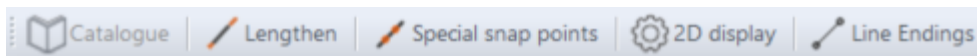

### Catalog

Auxiliary elements that are used frequently are stored in the catalog. Further information on [catalogs](#)<sup>[150]</sup> can be found in the **General properties dialogs** chapter.

### Extend

The [Extend](#)<sup>[142]</sup> properties dialog is described in the General **properties dialogs** chapter.

### Special snap points

The Special [snap](#)<sup>[143]</sup> points properties dialog is described in the General **properties dialogs** chapter.

### Contour

The [Contour](#)<sup>[138]</sup> properties dialog is described in the General **properties dialogs** chapter.

### Line ends

The [Line](#)<sup>[142]</sup> ends properties dialog is described in the General **properties dialogs** chapter.

## 16.7 Pictures

Image files can be inserted in Plan7Architect.

To do this, select the **Import image file** button in the design bar

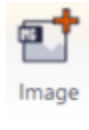

Alternatively, you can call up the same function in the pull-down menu under **File|Import|Import image** ...in the pull-down menu:

The Windows dialog for opening the desired file opens. The file is placed in the current layer in the middle of the planning. The image is displayed in the calculated size as a rectangle.

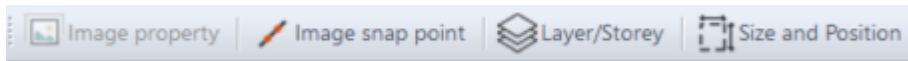

**Image editing** properties dialog

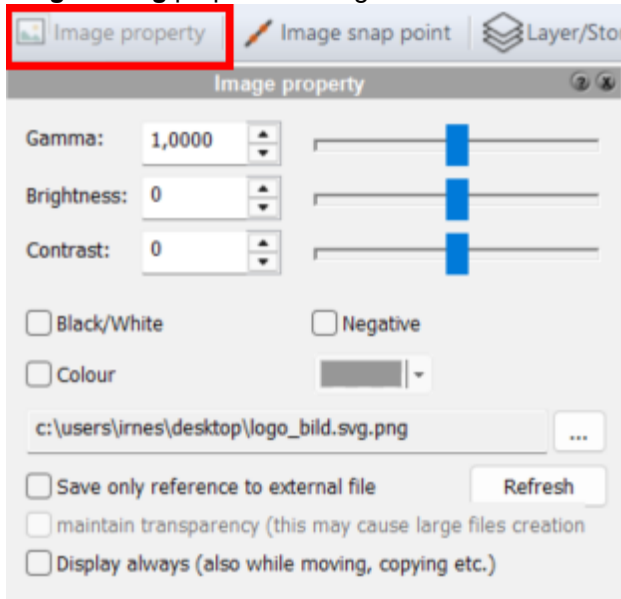

Properties of the image file can be changed here, such as brightness, contrast, etc.

**Image snap points** properties dialog

If required, snapping to pixels can be activated here.

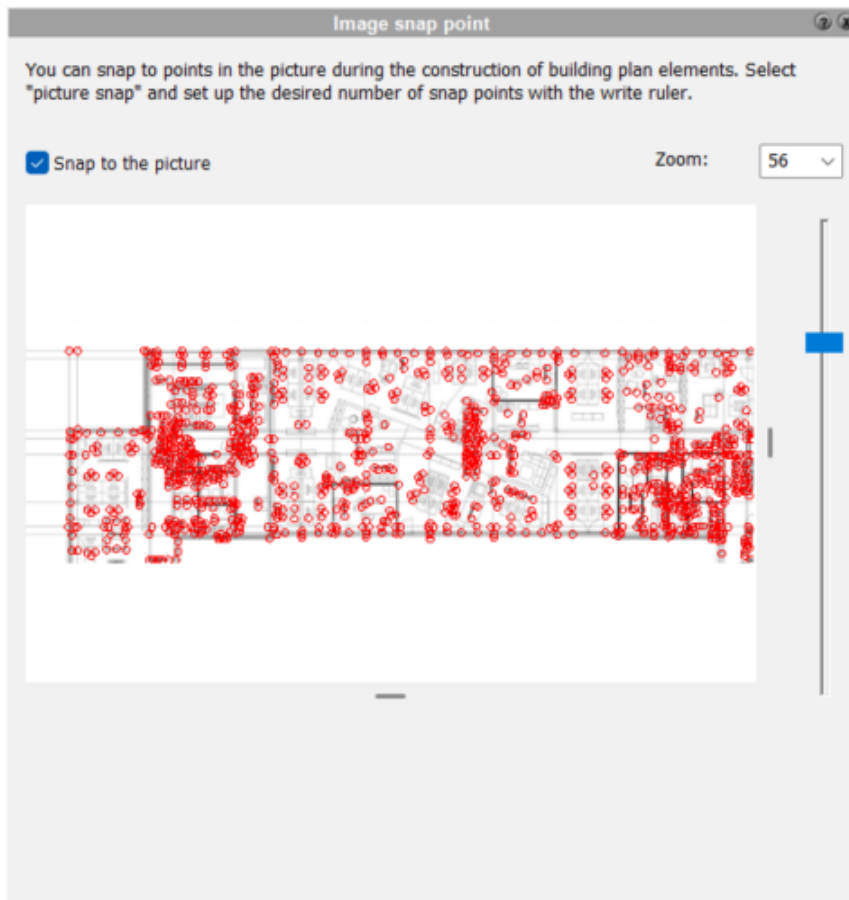

For information on the [Layer/Bullet](#)<sup>[143]</sup> and [Size/Position](#)<sup>[143]</sup> properties dialogs, please refer to the [General properties dialogs](#)<sup>[134]</sup> chapter.

## 16.8 Scanwizard

Information on the Scan Wizard can be found here:

[Scan Wizard](#)<sup>[50]</sup>

[Reload drawing \(image\)](#)<sup>[50]</sup>

[Optimize drawing \(image\)](#)<sup>[51]</sup>

[Alignment](#)<sup>[52]</sup>

[Determine scale](#)<sup>[53]</sup>

[Snap points](#)<sup>[54]</sup>

## 17 Edit

### 17.1 Transfer properties

Click on the **Get / transfer properties** button in quick access



The pipette can be used to quickly transfer properties from one element to other elements. You can determine which properties these are in the input options screen.

This function can actually be used to edit all Plan7Architect elements.

Properties can also be transferred between different elements, for example from rooms to walls. The same properties are always transferred (i.e. fill to fill, contour to contour). Properties that do not exist are simply omitted.

#### Which properties can be transferred?

There are basically two options:

1. for components with master data (these have a catalog), this same master data can be transferred to other elements of the same type. To do this, select Master data in the first selection list.

The lower area of the dialog is not active.

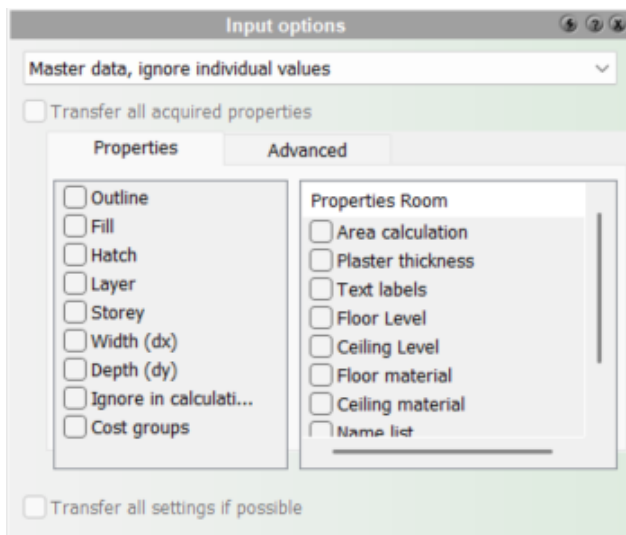

2. contour, fill, hatching, layer and storey can be transferred for all elements with the corresponding properties. (If the element has these properties). For components, the specific properties (here for a wall) are listed on the right. If you select Transfer all properties, all properties are selected and transferred to other elements. In the other case, this can be determined individually for each property.

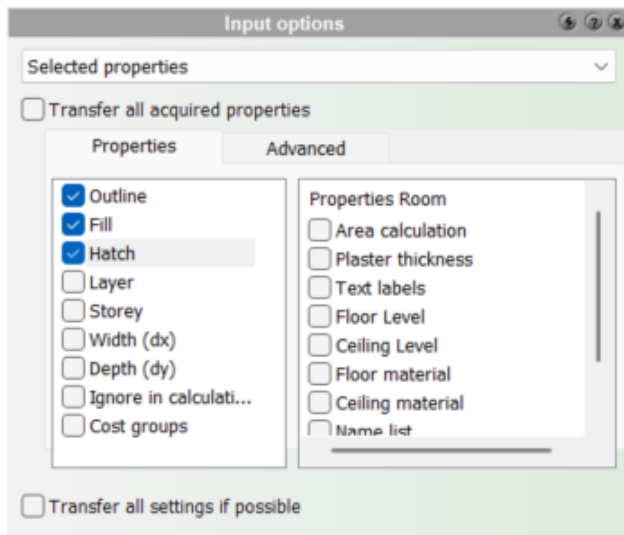

The extended properties for the mass determination can be selected in the Extended tab.

With the project explorer, tapped properties can also be transferred to several elements at the same time.

## 17.2 Editing tools

This chapter describes the **Move**, **Copy**, **Stretch**, **Stretch**, **Rotate** and **Mirror** functions. These functions can be used to select and simultaneously edit any selection of elements. Please note that only elements from unprotected layers and stories can be selected and edited. Please note the settings for layers in the **Basics** chapter.

The following applies to all editing tools: first the drawing elements are selected, the selection is ended with **[Esc]**, then the action is executed.

After execution, the command for re-execution is displayed again next to the selection. You can now select elements again and move them, for example, or end the command with **[Esc]**.

The editing tools are available in all two-dimensional modes.

The examples always use very simple elements such as 2D lines to enable the user to "redraw" quickly.

Click on the **Edit** button.

The various editing tools then appear in the **dialog bar**:

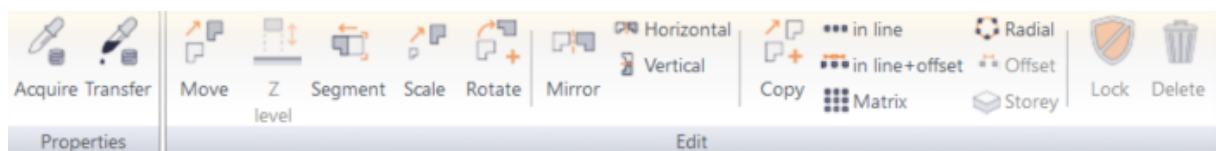

Select the **editing tool** by clicking on the corresponding button.

### 17.2.1 Move

Click on the **Move** button in the dialog bar .

Basic procedure:

- Select the elements to be moved by clicking or dragging an area.



- End the element selection with **[Esc]**.
- Enter the starting point for the move by clicking the mouse (reference point)
- The elements are displayed dynamically at the mouse pointer.
- Now enter the end point of the move by clicking the mouse.
- The elements are placed.
- Exit the command with **[Esc]** or select elements to execute the **Move** command again.

The distance between the start and end point of the move can be determined as follows:

### 1. The distance is a numerical value:

A line should be moved 100 cm to the left and 50 cm upwards.

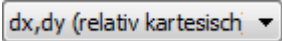
#### Step by step:

1. Draw any line.
2. Change to the coordinate system dx,dy - relative Cartesian.  

3. Select the **Move** command. 
4. Click on the line to select it.
5. Press **[Esc]** to end the selection.
6. Click anywhere on the drawing area for the starting point.
7. Press the **[Space]** key to start entering the coordinates.
8. Enter **100** and confirm with **[Enter]**.
9. Enter **50** and confirm with **[Enter]**.
10. The line has now been moved, press **[Esc]** to end the command.

### 2. The distance can be taken from the planning:

A line is to be moved so that a point on the line is placed on another snap point.



#### Step by step:

1. Draw any two lines.
2. The coordinate system used is irrelevant for this example.
3. Select the **Move** command. 
4. Click on the first line to select it.
5. Press **[Esc]** to end the selection
6. Click on the end point of the first line, which serves as the reference point for the move.
7. Snap an end point of the second line to which the selected end point of the first line will be moved.
8. The line is now shifted, press **[Esc]** to end the command.

### 3. The complicated case: the combination of 1. and 2:

The end point of the line should have a defined distance to a snap point.

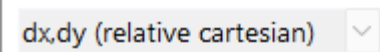
#### Step by step:

1. Draw any two lines.
2. Change to the coordinate system **dx,dy - relative Cartesian**.  

3. Select the **Move** command. 
4. Click on the first line to select it.
5. Press **[Esc]** to end the selection.
6. Snap an end point of the first line as the start point.
7. Press the shortcut key **B** to place the **working point**.
8. Snap an end point of the second line.

9. Press the **[Space]** button to start entering the coordinates.
10. Enter **100** and confirm with **[Enter]**.
11. Enter **50** and confirm with **[Enter]**.
12. The line has now been moved, press **[Esc]** to end the command.
13. The end point of the first line should be at the correct distance (100/50) from the end point of the second line.

All examples are based on the settings ***dx,dy - relative cartesian*** as coordinate system and the unit ***cm***. If the settings differ, the user should take this into account accordingly.

## 17.2.2 Change Z-height

Changing the **Z-height** in 3D mode:



**Change Z-height** dialog:

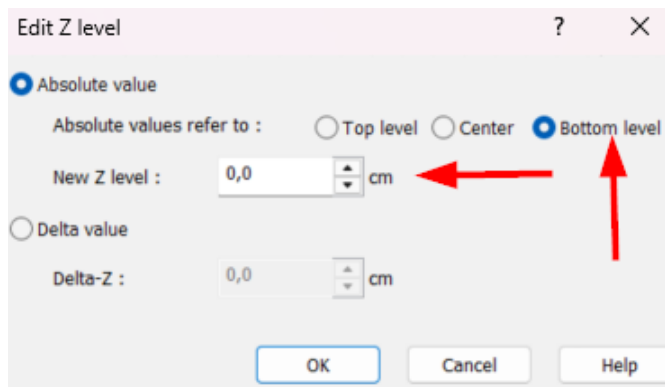

The Z-height of two elements has been moved upwards by 100 cm from the bottom edge:



### 17.2.3 Copy

Click on the **Copy** button in the dialog bar . The **Copy** command is used in the same way as the **Move** command described above, but the source element is retained.

### 17.2.4 Routes (S)

Click on the **Stretch** button . The **Stretch** command causes all end or corner points of elements that lie within the area you have defined to be moved by a distance.

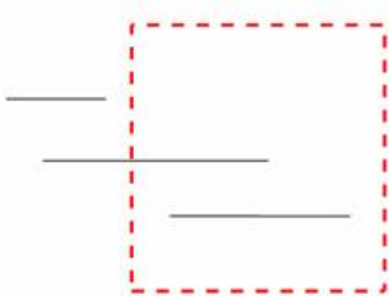

This means for the example above:

- The first line is not stretched, it lies completely outside the area.
- The second line is extended, the right end point is moved by the stretch distance.
- For the third line, both end points are moved.

#### Step by step:

1. Draw a rectangle consisting of 4 lines.
2. Change to the coordinate system dx,dy - relative Cartesian.
3. Select the **Stretch** command .
4. Define an area around 2 corner points of the rectangle (polygonal).

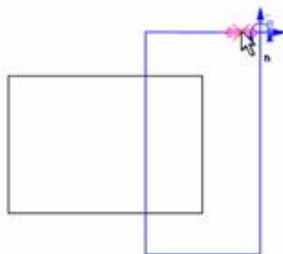

5. End the input of the area with **[Esc]**.
6. Now define the stretch distance.
7. Click anywhere on the drawing area as the first point.
8. Now press the **[Space]** key to start entering the coordinates.
9. Enter **100** and press **[Enter]**.
10. Press **[Enter]** again to confirm **0** in the Y direction.
11. The rectangle has been stretched by 100 cm.
12. Press **[Esc]** to end the command.

## 17.2.5 Stretching

Click on the **Stretch with any center** . With this function, drawing elements can be enlarged or reduced by a % value. X and Y stretching can be defined separately. All drawing elements are changed, but walls retain their original thickness.

 Possible input options:

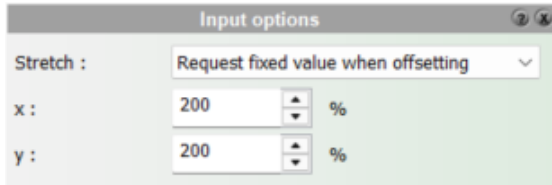

**Elongation** - Should the dialog for entering values be opened or not when the function is executed.  
**x and y** - Value of the elongation in x and y direction

### Application:

- Select the elements to be stretched (individually or by dragging an area)
- End the selection with **[Esc]**.
- Position the stretching center point.
- Enter the desired stretching factors (with the Ask option).

## 17.2.6 Turning (D)

Click on the **Rotate around any point** . This command rotates the selected elements around a freely placeable pivot point.

 Possible input options:

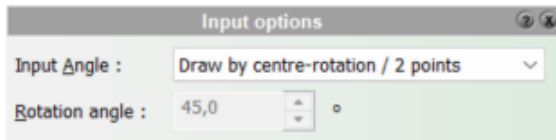

**Angle input** - How would you like to define the rotation angle (see description below)  
**Rotation angle** - value input for entering a fixed rotation angle

### Selection options for angle input

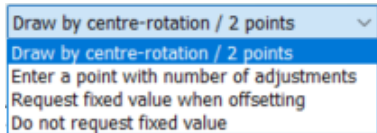

### Enter a point

With this method, the rotation angle can be taken from the drawing of existing elements (and their end points).

- Select the elements to be rotated and end the selection with **[Esc]**.
- Position the pivot point.
- Define the direction of rotation freely with the mouse or by snapping.

### Enter a point with number of adjustments

With this method, the rotation angle can be taken from the drawing of existing elements (and their end points) and subsequently adjusted.

- Select the elements to be rotated and end the selection with **[Esc]**.

- Position the pivot point.
- Define the direction of rotation freely with the mouse or by snapping.
- The form with the rotation angle opens. The current rotation angle is displayed. You can adjust this value if necessary.

#### Request fixed value when offsetting

The rotation angle is entered numerically and can be changed when executing the function.

- Select the elements to be rotated and end the selection with **[Esc]**.
- Position the pivot point.
- The form with the rotation angle opens.

#### Do not request fixed value

The rotation angle is specified numerically in the options. You are not prompted for the value again during editing.

- Select the elements to be rotated and end the selection with **[Esc]**.
- Position the pivot point.

#### Application:

- Select the elements to be stretched (individually or by dragging an area)
- End the selection with **[Esc]**.
- Place the point around which you want to rotate.
- The rotation is carried out according to the specifications in the input options

## 17.2.7 Mirroring (I)

Click on the **Mirror** button . This command mirrors the selected elements on a freely definable axis. The original element can optionally be retained. Required input: Selection of the elements, 2 points for the axis



Possible input options:

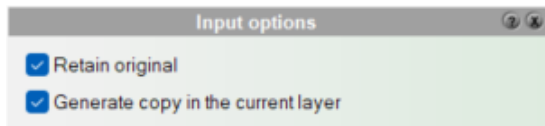



**Retain original** - the selection is mirrored, but the original element is retained

**Copy in current layer** - the copied, mirrored element is stored in the current layer (walls remain in the **Construction** layer )

A line is to be mirrored on a vertical axis, the original element is to be retained. The axis is selected at a defined distance from the line.

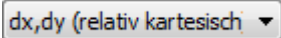

#### Step by step:

1. Draw any line.
2. Change to the coordinate system dx,dy - relative Cartesian  

3. Select the **Mirror** command .
4. Open the input options and select the **Keep original** option.
5. Click on the line to select it.
6. Press **[Esc]** to end the selection.
7. Press the shortcut key **B** to place the working point.
8. Snap an end point of the line.
9. Press the **[Space]** key to start entering the coordinates.
10. Enter **100** and confirm with **[Enter]**.
11. Press **[Enter]** again to confirm the suggested **0**.

12. The first point of the mirror axis is now positioned.
13. Place the second point vertically below the first point. The snap directions should be activated.
14. The line is now mirrored, press **[Esc]** to end the command.

### 17.2.8 Copy series

Click on the **Multiple copy in series** button . The selection is copied multiple times.

The number of copies is set in the **input options**  .

### 17.2.9 Copy row defined distance

Click on the **Multiple copy in row with specified distance** button . The selection is copied several times by the specified distance.

The number of copies and the distance (optional clearance) are set in the **input options** .

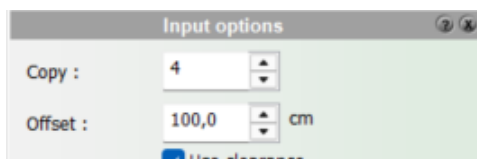

#### Application:

Select the elements to be copied (individually or by dragging an area) and end the selection with **[Esc]**. Define the starting point for the copies and specify the desired direction with another point. The selection is copied according to the specifications in the input options.

### 17.2.10 Copying in the grid

Click on the **Multiple copy in x and y direction with specified distances** . The selection of elements is copied in a grid/matrix (rows and columns).

The number of rows and columns is set in the **input options** . The distance is entered in the same way as the **Move** command.

### 17.2.11 Copying in a circle

Click on the **Circular multiple copy with specified angle** button . The copying process is carried out along an arc whose center is defined by the user. The radius of the arc is the distance from the center point to the center point of the selection (of the circumscribing rectangle).

 Possible input options:

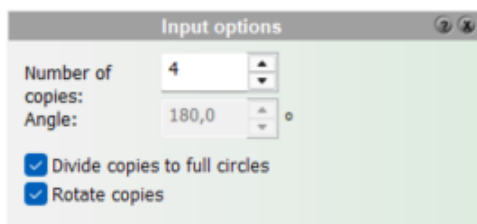

**Number of copies** - how often the selection is copied

**Angle** - the angle between the drop points

**Distribute to full circle** - the set number is distributed to a 360 degree angle, the angle setting is irrelevant for this option

#### Application:

Select the elements to be copied (individually or by dragging an area) and end the selection with **[Esc]**. Define the center point of the circle on whose arc the selection is copied according to the specifications in the input options.

## 17.3 Contour tools

This chapter describes functions for subsequently editing contours

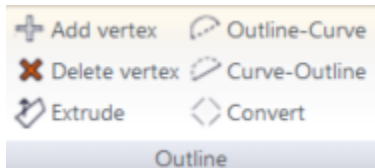

The various contour tools then appear in the *dialog bar*:

Select the contour *tool* by clicking on the corresponding button.

### 17.3.1 Edit contours

The commands described below can be used to insert, delete and edit contour points. These commands are executed in the floor plan view of roof contours, ceilings, ceiling openings and landings.

- **Insert point** **+**. Select the edge of the contour in which the new corner point is to be inserted. The corner point is created immediately.
- **Delete point** **×**. Click on the corner point to be deleted. This is removed and the display is updated. Please note that a contour must always have at least three corner points.

### 17.3.2 Extrude contour

Click on the **Extrude contour** button in the dialog bar . Any contours, for example 2D polygons, circles, spatial polygons etc. are used as the basis for creating 3D objects.

- Draw the plan view in **Construction** mode.
- Start the **Extrude contour** function.
- Select the elements, if necessary by dragging an area.
- The 3D object is created.

A 3D object created by extrusion has the additional **Extrude** properties dialog . This property is retained even after saving in the catalog.

Select the 3D object and open the properties dialog.

The extrusion body consists of a base surface, a cover surface and the side surfaces. The distance between the base and cover is the height.

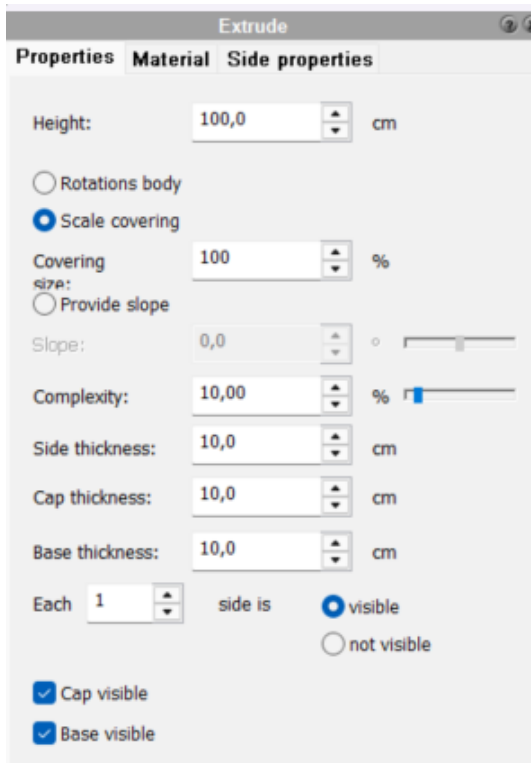

## 17.4 Groups

### 17.4.1 Grouping and ungrouping

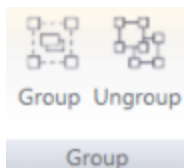

#### Creating a new group

Select all elements that are to be part of the new group. You can find more information on the topic of selecting in the chapter Basic knowledge/Selection. Once you have selected all the desired elements, select the Group command in the Edit menu. Optionally, you can also use the shortcut key **[Ctrl]+[G]**.

#### Dissolving a group

Select the group and choose the *Edit|Ungroup* command or optionally the shortcut key **[Ctrl]+[Shift]+[G]**.

#### Displaying groups

If you move the mouse cursor over an element of a group, the entire group is outlined with a dashed rectangle.

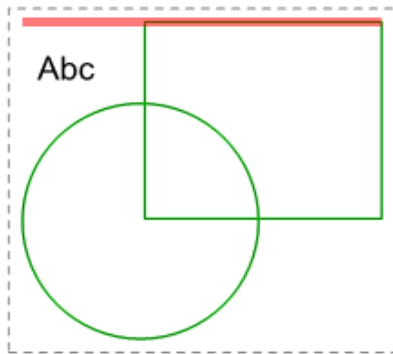

### Layers of groups and their elements

Like any other element, a group has a layer and a storey. All elements of the group are also on this layer/floor, regardless of the component type. If a group is dissolved, the elements are redistributed to the original layers.

### 17.4.2 Texts in groups

If texts are contained in groups, the content can be changed via the Texts dialog, dialog without dissolving the group.

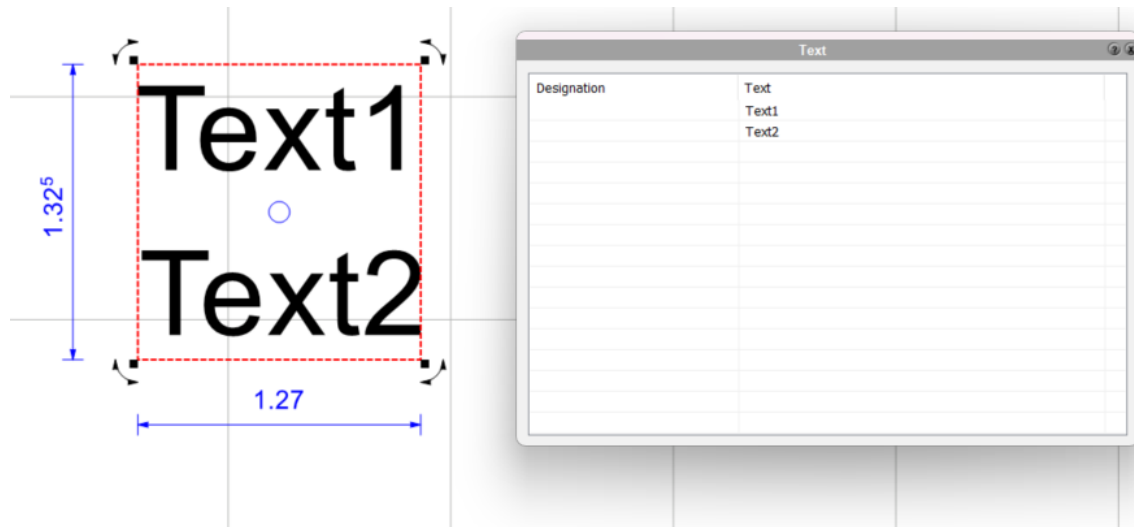

The use of form fields is recommended for more extensive groups, such as plan headers. The name of the form field appears next to the text in the Description column. This makes it easier to identify which field is being edited.

### 17.4.3 Component templates and mass determination

Component templates for groups are managed in the same way as component templates for all other elements.

A part template can be assigned to a group in the catalog. (or via the selection list in the dialog bar). If a new group is created, the assignment can be made in the top selection list. Important! Assigning a template does not change the content of the group (the elements it contains). The assignment only serves to be able to calculate groups correctly with regard to mass determination. On the one hand, this is the addition of the same elements (e.g. all light switches), on the other hand, the content of the group can be excluded from the mass determination with the "Calculate lump sum" option.

An example of this: Several beams, panels and a roof are combined to form the "Carport" group.

Calculated as a lump sum, only a carport is listed in the mass evaluation, but not the grouped components.

If the mass determination of a group is not relevant (for plan symbols), there is no need to assign component templates.

With an additional option, the group can be calculated again with its individual parts after a size change.

#### 17.4.4 Labeling

Groups can be labeled with their name and description.

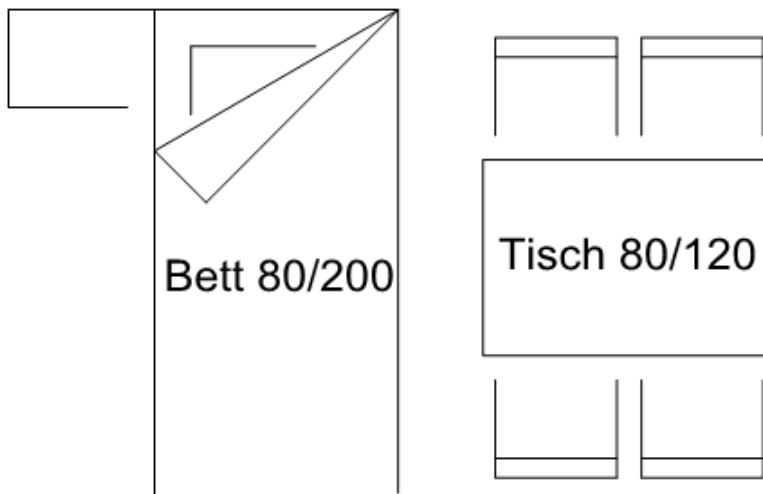

The settings in the *Project|Labeling* menu - *Groups* tab are important for displaying the text. Read more on this topic under [Groups](#)<sup>[210]</sup>

The labeling can be moved freely. Each group also has individual parameters independent of the global settings. Select a group and open the Labeling dialog.

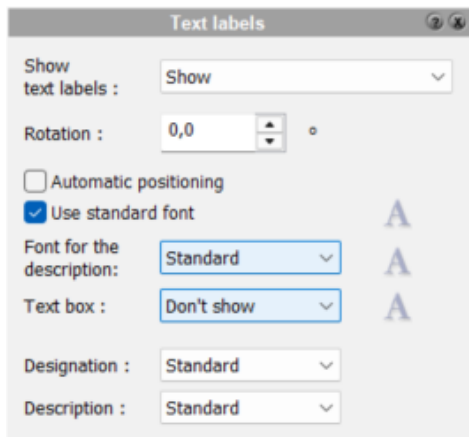

Display the label of this group

The rotation angle of the label

The label is automatically centered below the group. If you move the position of the text, this option is not active. Activate this option to move the text back to the default position.

Display and parameters of the frame around the text

Show label/description

The group labeling can be switched on or off globally (**ProjectLabeling**); this applies to the editing of all other projects until another option is selected again

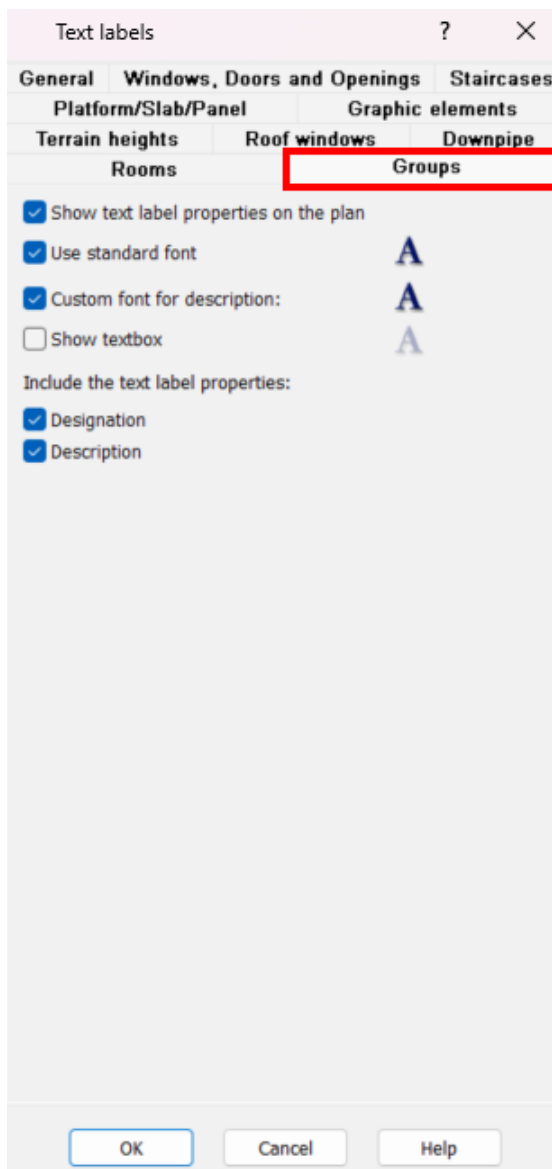

## 17.5 Organize

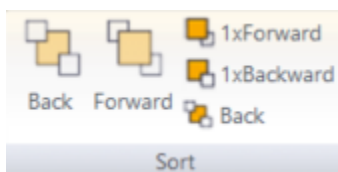

The visibility of elements in the 2D area can be defined using the functions in the Order area. With a few exceptions, the visibility of 2D elements is determined by the order in which they are drawn. For example, if you draw two polygons that overlap, the last one drawn is displayed above. The polygons of rooms, for example, are an exception; they are always completely in the background

These functions can be used to change this order.

At the back ..... Moves the selected element to the very back of the display sequence

Front ....	Moves the selected element all the way to the front in the display sequence
1x Front ....	Moves the selected element forward by one in the sequence
1xBehind ....	Moves the selected element back by one in the sequence

All the way back .... In 2-D views with shading, the image is placed as a bitmap in the background of the 2-D view. If an element is now moved all the way to the back using the function, it is also behind the calculated bitmap.

## 17.6 Clipboard

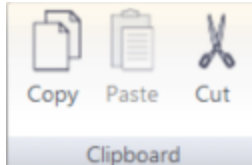

The clipboard functions can be used to copy elements within the drawing but also between different projects.

- Select the desired elements and choose the copy function
- The selected elements are copied to the clipboard
- Select the Paste function in the same or another project and the elements are attached to the mouse pointer for pasting and can be placed

If you use the Cut command instead of the Copy command, the original elements are deleted after the copying process.

## 18 Trimming tools

This chapter describes the functions *Trim*, *Extend* and *Split*.

The various trimming tools then appear in the *dialog bar*:

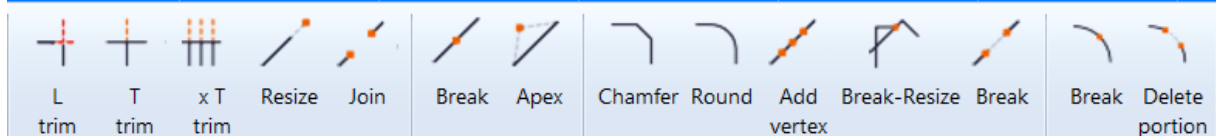

Select the *trimming tool* by clicking on the corresponding button.

### 18.1 L-Trimming (L)

Click on the *L-trim* button in the dialog bar. Two elements are to be trimmed at the intersection point, protruding ends are cut off.

The end that was clicked on during the selection remains.

This command can be used for lines, arcs, circles, walls and beams.

### 18.2 T-Trimming (T)

Click on the *T-trim* button in the dialog bar. An element is cut off at a trimming edge (also an element from the list below) or extended up to the trimming edge.

This command can be used for lines, arcs, circles, walls and beams.

**Procedure:**

- Select the element to be trimmed.
- Select the element as the trimming edge.

### 18.3 T-Trimming (multiple)

Click on the *Trim multiple* button in the dialog bar. This function can be used to trim several elements on one edge.

First select the trimming edge. Now click on the elements one after the other. They are cut off at the edge (if they intersect it) or extended up to this edge. If the element is trimmed, define the side that is retained by clicking (selecting) the element on this side.

### 18.4 Extend (G)

Click on the *Extend* button in the dialog bar. Use this command to dynamically move an end point of a drawing element. The object direction is retained. This command can be used for lines, walls and beams.

**Procedure:**

Select the element near the end to be extended.  
Place the end point.

**Step by step:**

1. Draw two parallel walls of different lengths.

2. Press **G** to **extend**.
3. Select a wall near an end point.
4. Snap to the corresponding end point of the other wall.
5. Both end points should now be aligned.

## 18.5 Connect

Click on the Connect button in the dialog bar. Use this command to reconnect two lines or two walls that have been split.

## 18.6 Break open (A)

Click on the **Break up** button in the dialog bar. Use this command to split a drawing element into two parts at one point. This command can be used for lines, walls and beams.

### Procedure:

- Select the element.
- Place the point at which the element is to be split.

## 18.7 Break open the roof

This function is intended to help you determine the length of a wall in the area of dormers.

Select the dormer wall, the function now expects you to enter a second point.

Move the mouse pointer along the wall axis and a snap point will also be offered in the area where the dormer wall intersects the roof. If you now select this point, the wall will be split at this point.

## 18.8 Chamfering

Click on the **Chamfer** button in the dialog bar. This command can be used for lines. Two lines can be given a chamfer at their intersection.



Possible input options:

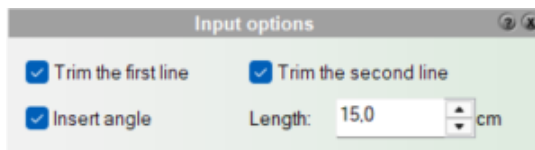

Select 2 line ends with a mouse click. The line ends are given a chamfer according to the specifications in the input options.

## 18.9 Rounding

Click on the **Round** button in the dialog bar. This command can be used for lines. Two lines can be rounded off at their intersection.



Possible input options:

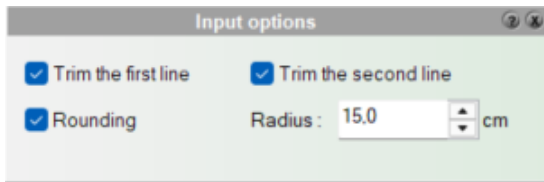

Select 2 line ends with a mouse click. The line ends are rounded according to the specifications in the input options.

## 19 Dimensioning

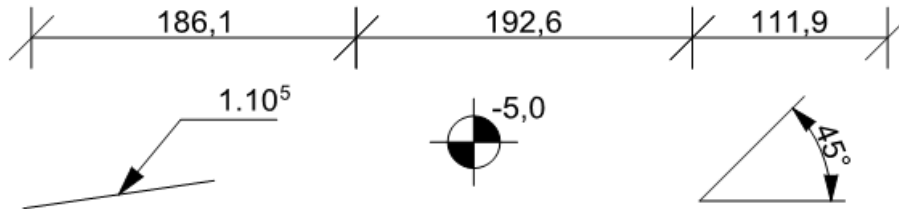

### 19.1 Introduction

Linear distance dimensions are each defined using two dimension points. These points are shown as soon as the dimension chain is selected or the mouse pointer is moved over the dimension line.

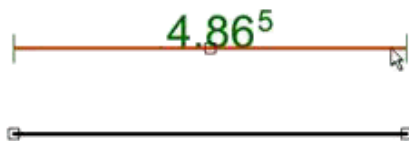

In this example, a line has been dimensioned. You can see the dimension points at the end points of the line. These dimension points define the distance to be measured, i.e. the correct dimension. It is very important to place the dimension points correctly on the element.

The position of the dimension points can be changed simply by moving them with the mouse (left mouse button pressed).

The handle in the middle of the dimension line is used to move the dimension chain without moving the dimension points.

### 19.2 Property dialogs



Essentially, all properties dialogs are always the same for all dimensioning types. All properties dialogs are explained using the example of linear distance dimensioning. Deviations for other dimensioning types are also mentioned in the corresponding chapter.

#### 19.2.1 Catalogue

Measurements that are frequently used are stored in the catalog. Further information on the [catalogs](#)<sup>[150]</sup> can be found in the [General properties dialogs](#)<sup>[134]</sup> chapter.

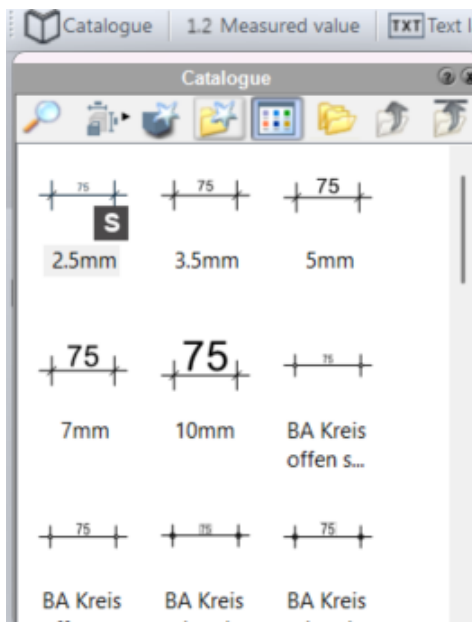

### 19.2.2 Layer/Floor

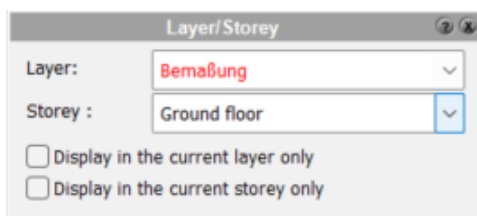

In this dialog, as with all other elements, the layer and storey can be changed according to the dimensions. For dimensions in particular, the **Show only in current layer/storey** options must be selected. This is useful for dimensions, as several layers and storeys are often visible in the construction of buildings, but the simultaneous display of all dimensions is very confusing. For more information, see [Layer/floor](#)<sup>[143]</sup> in the [General properties dialogs](#)<sup>[134]</sup> chapter.

### 19.2.3 Size and Position

The **Size/Position** form allows you to specify the size of the dimensioning, the rotation and the position in the planning alphanumerically. For more information, see [Size/Position](#)<sup>[143]</sup> in the [General properties dialogs](#)<sup>[134]</sup> chapter.

## 19.2.4 Dimension

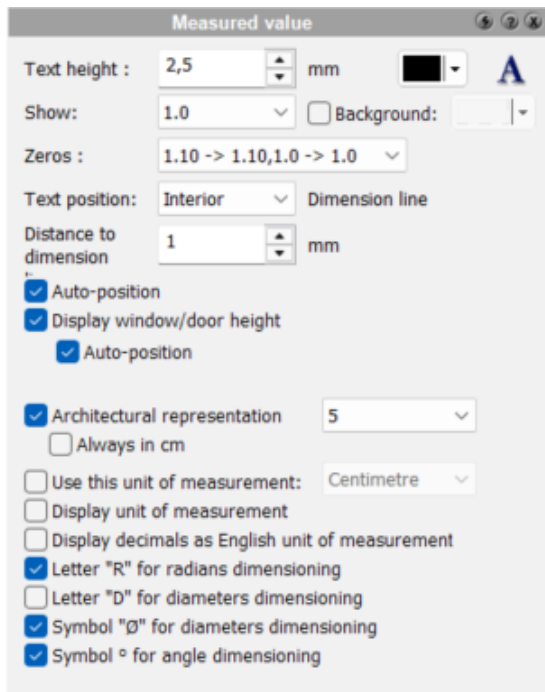

**Text height:** The text height of the dimension in mm on the paper. This value is automatically adjusted when the scale is changed so that the text height on the printout remains the same. The color and font can be changed.

**Display:** Does not apply to architect-oriented display. This parameter controls the decimal places (rounding) of the dimension. The selection ranges from none to a maximum of three decimal places.

**Zeros:** Does not apply for architect-oriented display. This parameter controls the display of the zeros in the decimal point range. For all the following examples, the *Display* value was set to **1,000** (3 decimal places).

### 1,10 -> 1,10; 1,0 -> 1,0:

The number of decimal places remains the same (as selected in Display), regardless of whether the displayed value contains zeros or not.

Examples: 1.000 becomes 1.000  
 1.200 becomes 1.200  
 1.240 becomes 1.240  
 1.243 becomes 1.243

### 1,10 -> 1,1; 1,0 -> 1,0:

Zeros in the decimal place range are truncated up to a maximum of the first decimal place.

Examples: 1.000 becomes 1.0  
 1.200 becomes 1.2  
 1.240 becomes 1.24  
 1.243 becomes 1.243

### 1,10 -> 1,1; 1,0 -> 1:

All zeros in the decimal place are removed.

Examples: 1,000 becomes 1  
 1,240 becomes 1,24  
 1,240 becomes 1,24

1.243 becomes 1.243

**Text position:** Position of the dimension text in relation to the dimension line

**Distance to dimension line:** Distance between the bottom edge of the dimension text and the dimension line

**Automatic positioning:** The dimension text can be moved to any position using the mouse. The **Automatic positioning** radio button is not active. If you activate it again, the dimension text is reset to the automatically calculated position.

**Display window or door height:** The heights of window or door openings are displayed below the dimension line for building-compliant dimensioning. The prerequisite for this is that both dimension reference points are offset at window or door points.

**Architect-compliant display:** Regardless of the **Display** and **Zeros** settings for rounding, all dimensions are always displayed in the architect-compliant display. The parameter **always in cm** controls whether a point is used as a separator before the third digit before the decimal point.

Examples:

architekturegerechte Darstellung  
 immer in cm

1152.35 cm are displayed as 11.<sup>525</sup>

52.35 cm are displayed as<sup>525</sup>

52.15 cm are displayed as 52

architekturegerechte Darstellung  
 immer in cm

1152.35 cm is shown as<sup>11525</sup>

52.35 cm are displayed as<sup>525</sup>

52.15 cm are displayed as 52

**Use your own unit of measurement:** Does not apply to architect-oriented representation. A unit of measurement other than the project unit of measurement is used for this measurement.

**Show unit of measurement:** Does not apply for architect-oriented representation. The unit of measurement is displayed after the measurement.

## 19.2.5 Dimensional labeling

The screenshot shows a dialog box titled "Text labels dimensions". It contains three radio button options: "Use automatic generated text label" (which is selected), "Constant value:" (with a numeric input field containing "0,0" and a unit dropdown set to "cm"), and "Text label:" (with an empty text input field). Above these options are two empty text input fields labeled "Prefix" and "Suffix".

There are three ways to define the content of the dimension.

- The **automatic label** is the value determined from the drawing, i.e. the distance between the dimension points or the angle between two lines, etc.
- The **fixed value** is required to display a number independently of the correct value determined from the drawing.
- The **label** allows free text to be displayed as a "dimension".

#### Pre-texts and post-texts:

These texts are available for all dimensions except wall dimensions.

### 19.2.6 Dimension line

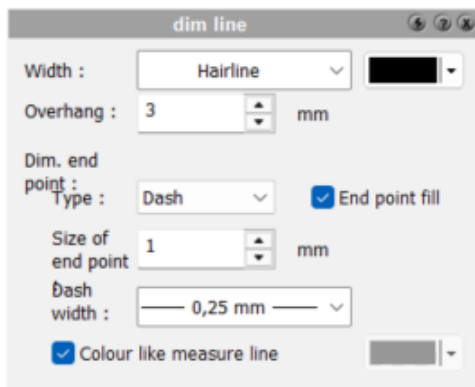

**Width:** Define the line width of the dimension line and select the color if necessary

**Overhang:** The overhang is the lateral extension of the dimension line.

**Dimension ends:** There are four representations to choose from: none, line, circle and arrow

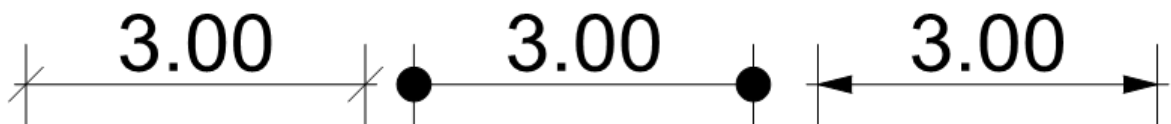

The ends for the circle and arrow can be filled or only displayed with their outline

### 19.2.7 Dimension guidelines

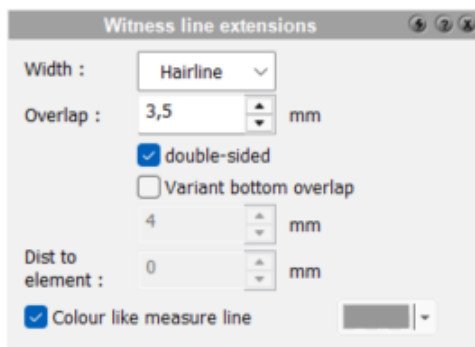

Auxiliary dimension lines are the lines perpendicular to the dimension line at the start and end points. Dimension lines can be routed with the overhang (same at the top and bottom) on both sides or up to the dimension points (with the distance up to the element).

The option **different bottom over** hang allows you to display a dimension chain with different overhangs at the top and bottom.

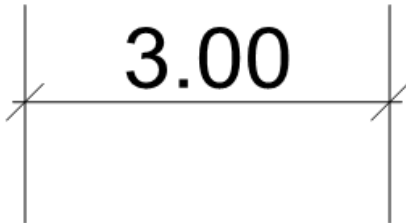

If the option **on both sides** is not active, the dimension line is extended to the dimension points, but the distance is also variable. (Distance to element)

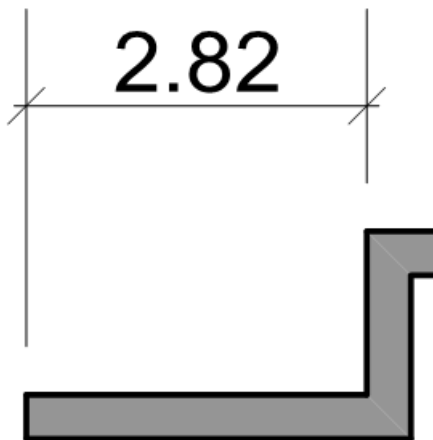

## 19.2.8 Tolerances

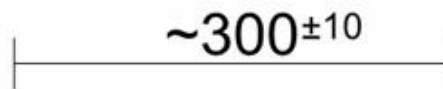
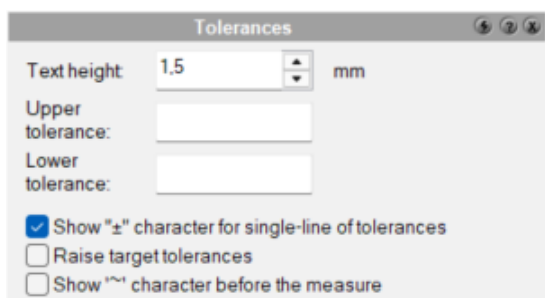

Tolerances can be displayed in addition to the dimensions.

These settings have no effect if the **Architect-specific display** option is selected in the **Dimension** dialog.

## 19.3 Linear dimensioning

### 19.3.1 Distance dimensioning

The distance dimensioning with variable direction is a linear dimensioning. The direction of the dimension line is defined before drawing.

- Click on the distance button  in the linear dimensions
- Various input options are now available to you

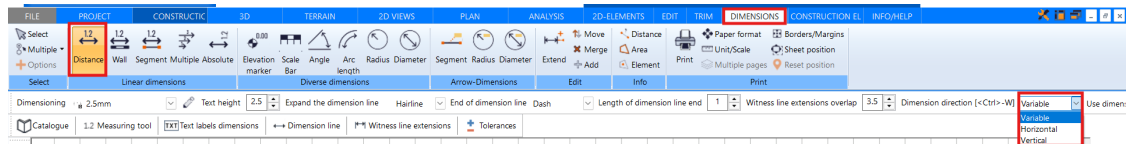

Under Dimension direction, you can select **Variable**, **Horizontal** and **Vertical**.

The **direction** of the dimension chain is defined by

- **Use dimension points** - The first two dimension points define the direction.
- **Enter two points** - Two points that determine the direction are queried before the dimension points are entered.
- **Snap direction** - Before the input, an edge of a drawn element is selected in order to draw the dimension chain parallel to it.
- **Use fixed value** - The direction of the dimension chain is defined by the adjacent value.

Example:

#### Dimensioning an angled wall with snapping to direction

1. Draw a wall with a window, the wall can have any direction.
2. Click on the Distance button  in the construction bar.
3. Select the dimension direction **Variable** and activate **Snap** to direction.
4. Click on a long side of the wall to determine the direction.
5. Snap the first two dimension points (an end point and the point closer to the window reveal).
6. Determine the position of the dimension line by clicking with the mouse.
7. The next point of the dimension line is the nearest point of the window.
8. Now click on the second end point of the wall
9. End the dimension chain with **[Esc]**
10. Exit the dimensioning command with **[Esc]**.

The result could look something like this:

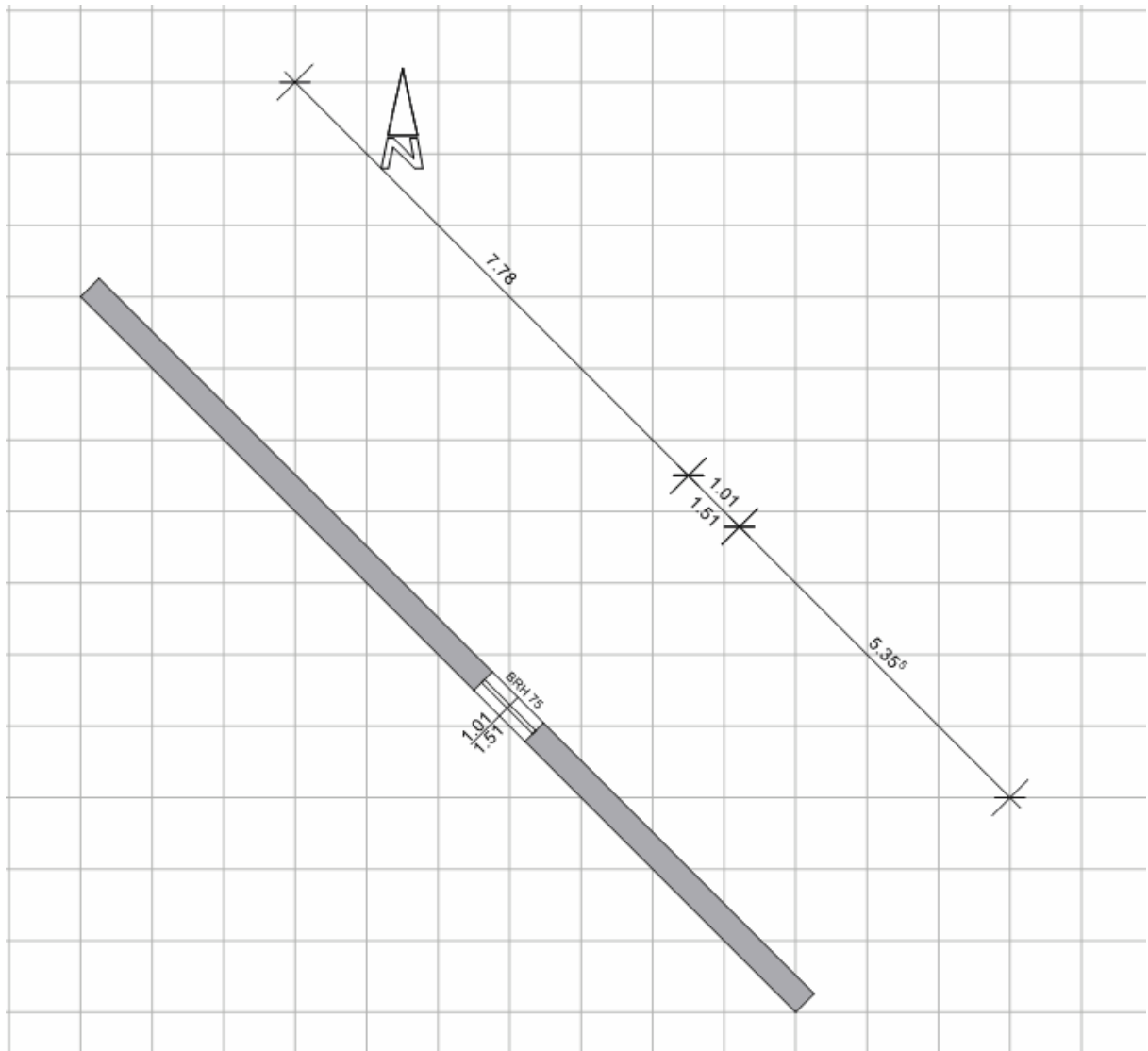

### 19.3.2 Wall dimensions

The **wall dimensioning** is an **associative** dimensioning that can generate complete dimension chains for one or more wall sides.

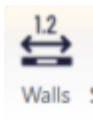

The properties of the dimension chains are defined via the catalog selection or via the standard values.

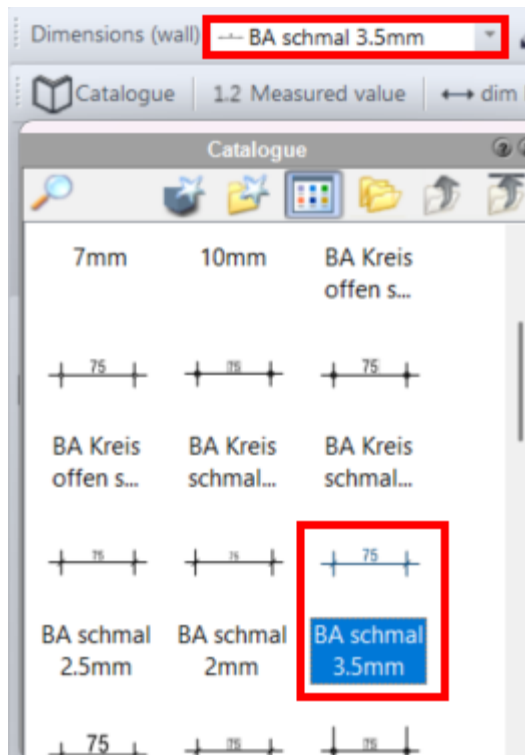

### 19.3.2.1 Drawing

In the wall dimensioning, click with the left mouse button on all wall sides that are relevant for the dimensioning. This selection is ended by pressing the **ESC** key.

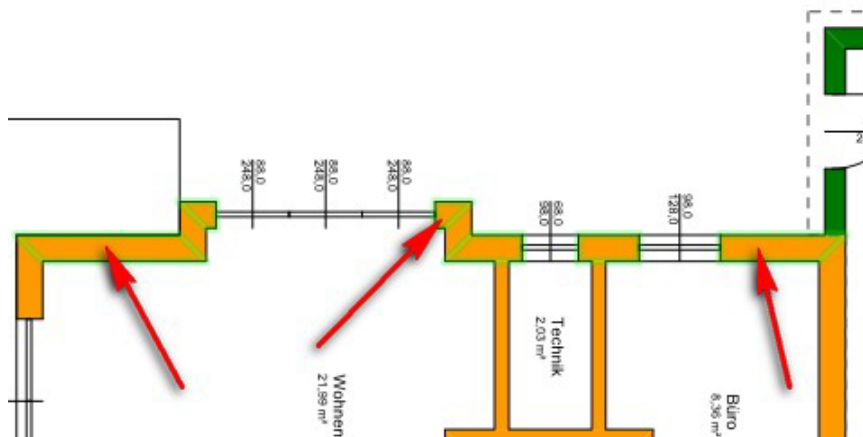

The reference directions must be selected with a left-click; the dimension chains are created parallel to these directions

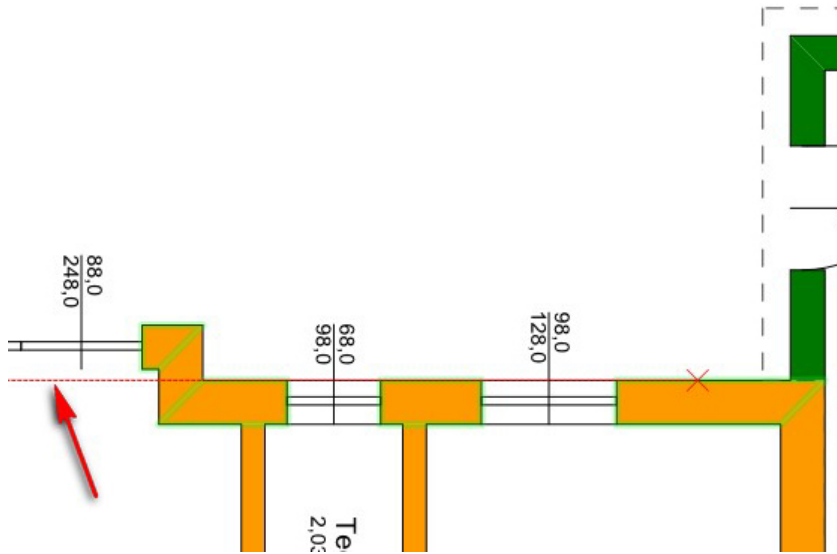

The dimension chain is attached to the cursor and can be placed in the planning.

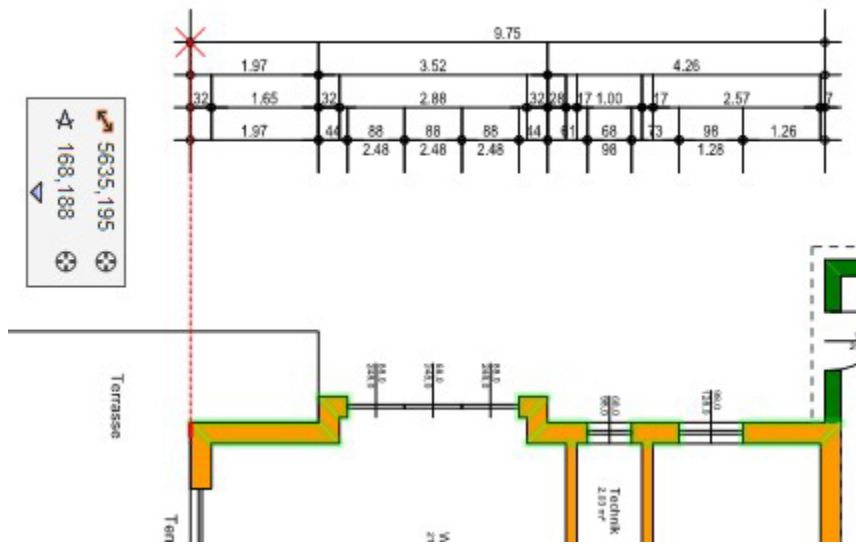

The complete chains of dimensions are set off and can be subsequently edited with all functions. The associativity is nevertheless retained.

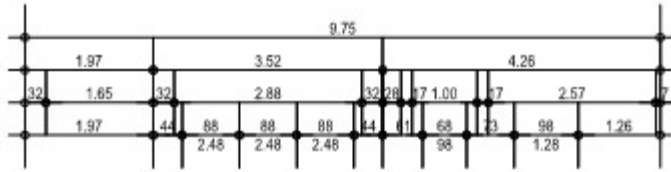

### 19.3.2.2 Change

Editing can be carried out using the right mouse button (e.g. Insert dimension point/Extend dimension chain)

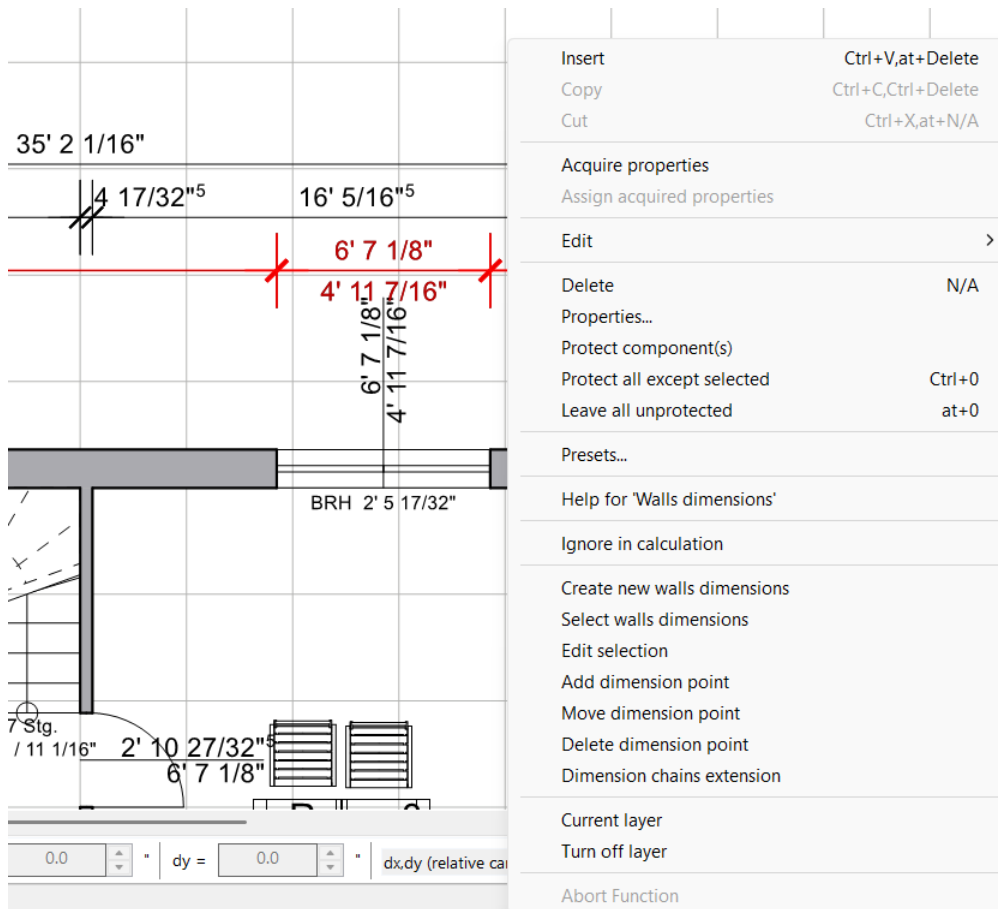

The wall dimensioning can also be easily moved as a complete block.

Click twice on the dimension chain until the block is highlighted in red and then move it with the mouse.

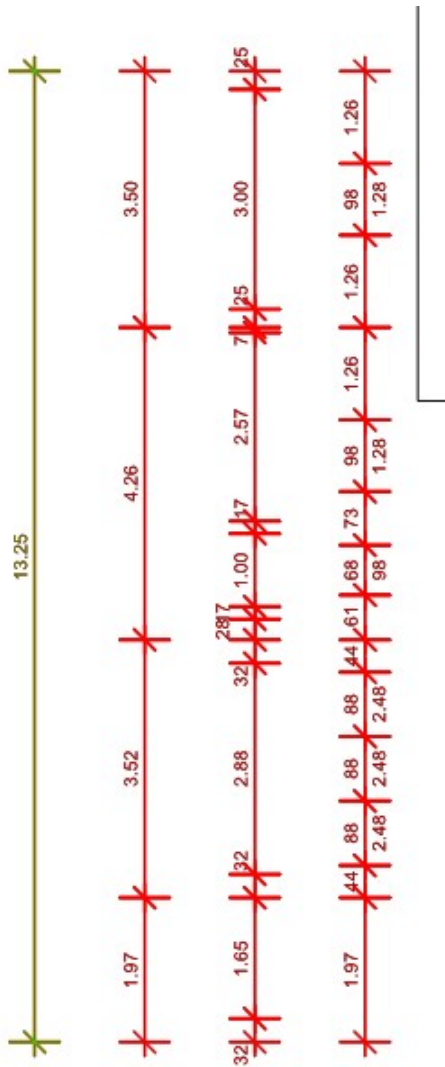

### 19.3.2.3 Edit

By clicking twice with the left mouse button, the entire block is marked and can be changed. The **External dimensions** container takes you to the wall dimension settings:

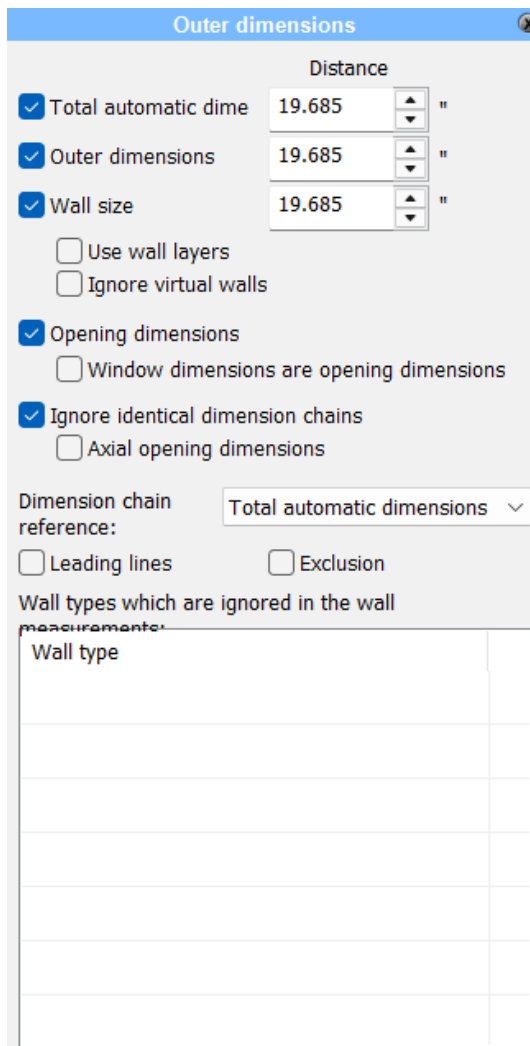

**Guide lines** relate the first dimension line to the house corners:

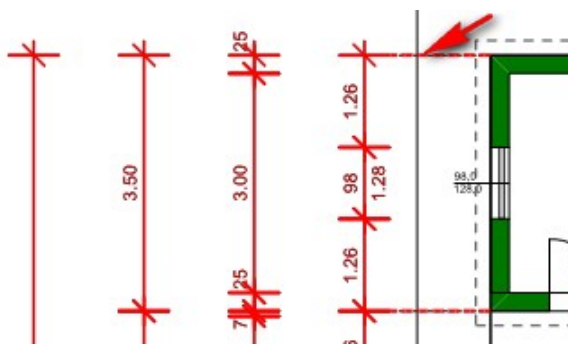

At the **end**, all dimension chains are also connected at house edges:

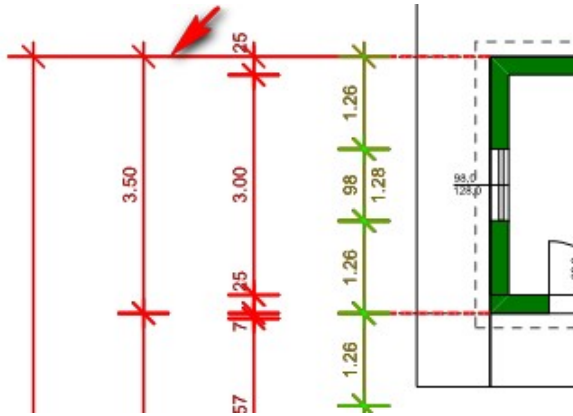

Under **Wall type**, special wall types can be stored that should not be included in the automatic dimensioning (e.g. demolition walls or installation walls):

right mouse button and then click on 'Add'

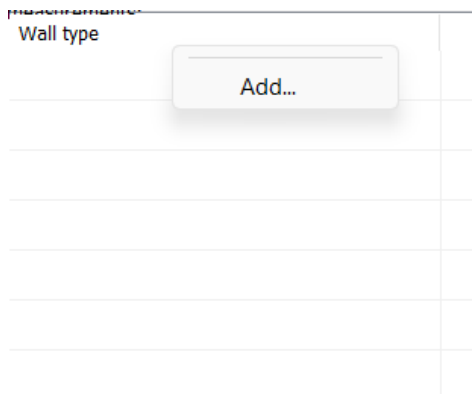

Select wall

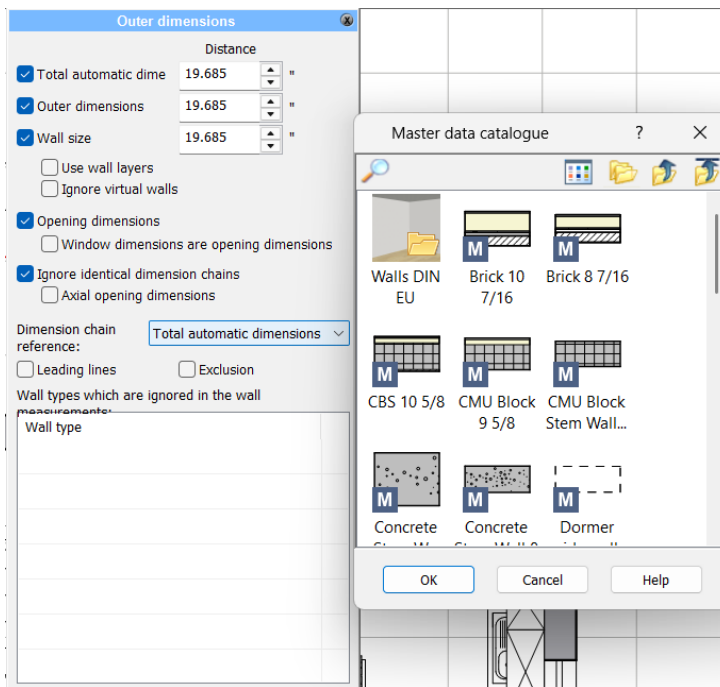

### 19.3.3 Line dimensioning

The **line dimensioning**  is used to create a dimension chain for an edge. The dimension chain is parallel to this edge. This dimensioning type can be used for wall segments, lines, edges of polygons, etc.

Use the 1st input point to select the distance to be dimensioned, the 2nd input point defines the position of the dimension chain.

### 19.3.4 Dimension arrow for distances

The **dimension arrow for lines**  is used to create a dimension chain for an edge. This dimensioning type can be used for wall segments, lines, edges of polygons, etc.

Use the 1st input point to select the distance to be dimensioned, the 2nd/3rd input point defines the position of the dimension arrow.

### 19.3.5 Multiple dimensioning

**Multiple dimensioning**  creates dimension chains that always use the same starting point (in contrast to the **multiple dimensions** parameter *as a dimension chain* in conventional *spacing dimensioning*).

The distance between the dimension chains is determined automatically from the text height of the dimension.

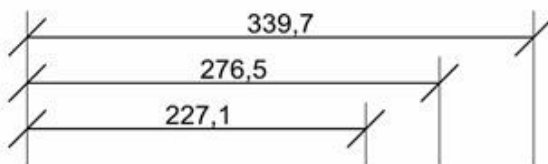

### 19.3.6 Edit

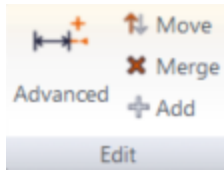

The following options are offered in the dialog bar:

- **Insert dimension point**

Select the dimension chain and then define the additional dimension point in the planning.

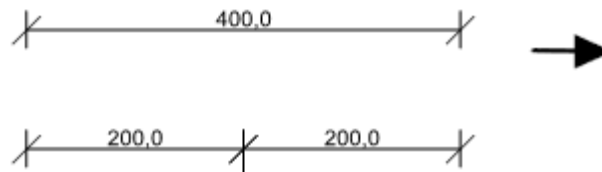

- **Merge dimension chain**

Select two adjacent dimension chains with the same orientation; a new dimension chain is created over the entire route.

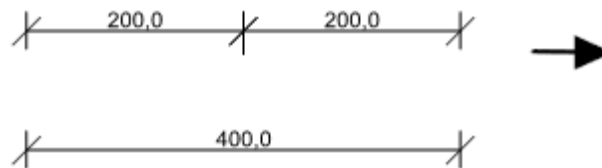

- **Extend dimension chain**

Click on an existing dimension chain and use the cursor to specify the direction in which you want to extend it.

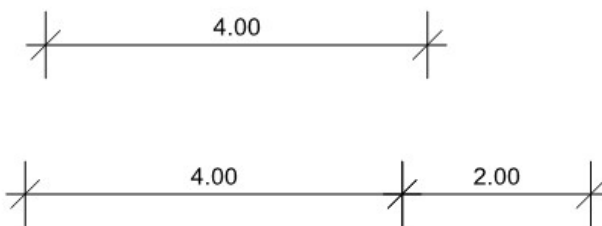

## 19.4 Circle and arc dimensions

### 19.4.1 Measure sheet length

The **measure arc length** input type  can be used for arcs.

The properties for **dimension number**, **dimension label** and **dimension line** are analogous to the *distance dimensioning*.

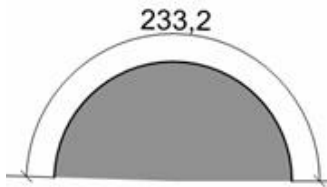

### 19.4.2 Radius dimensioning

The **radius dimension**  can be used for measuring arcs and circles. The properties for **dimension number**, **dimension labeling** and **dimension line** are analogous to the *distance dimensioning*. The radius dimensioning does not use dimension points, so it is not possible to change the dimensioning.

The **R** for *radius* is automatically displayed in the dimension text.



### 19.4.3 Dimension arrow for radii

The **dimension arrow for radii**  can be used to measure arcs and circles. The properties for **dimension number**, **dimension labeling** and **dimension line** are analogous to the *distance dimensioning*.

The radius dimensioning does not use dimension points, so it is not possible to change the dimensioning.

The **R** for *radius* is automatically displayed in the dimension text.

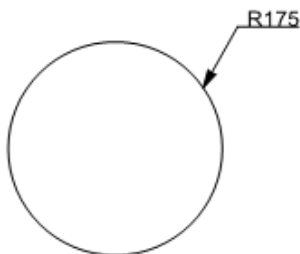

### 19.4.4 Diameter dimension

The **diameter dimensioning** input type  can be used for arcs and circles. A dimension chain with the properties for **dimension number**, **dimension label** and **dimension line** is created in the same way as the *distance dimension*.

The dimensioning has dimension points; if these are moved, the dimensioning can also be changed retrospectively. The  $\emptyset$  symbol for *diameter* is shown in the dimension text.

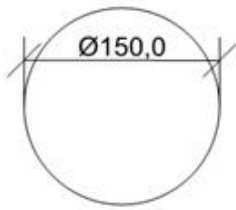

### 19.4.5 Dimension arrow for diameter



The **measuring arrow for diameters** can be used to measure arcs and circles. The properties for **dimension number**, **dimension labeling** and **dimension line** are analogous to the *distance dimensioning*.

The diameter does not use dimension points, so it is not possible to change the dimensioning. The  $\emptyset$  for diameter is automatically displayed in the dimension text.

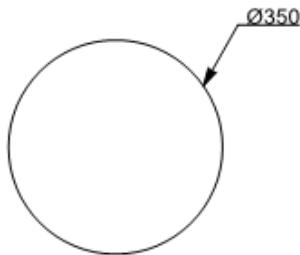

## 19.5 Angle dimensioning



Input type **Measure angle**

Angle measurements are entered counter clockwise. The angle is displayed in degrees.

The properties for the **dimension number**, **dimension label** and **dimension line** are the same as for *distance dimensioning*.

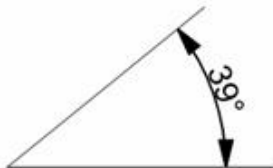

## 19.6 Height dimensions



The **height node** input type

Height dimensions can be placed in floor plans and 2D views. A circle (optionally also filled diagonally) is displayed as the height symbol in the floor plan and a triangle (arrow) in the 2D views.

Height dimensions have the additional properties dialog **node**.

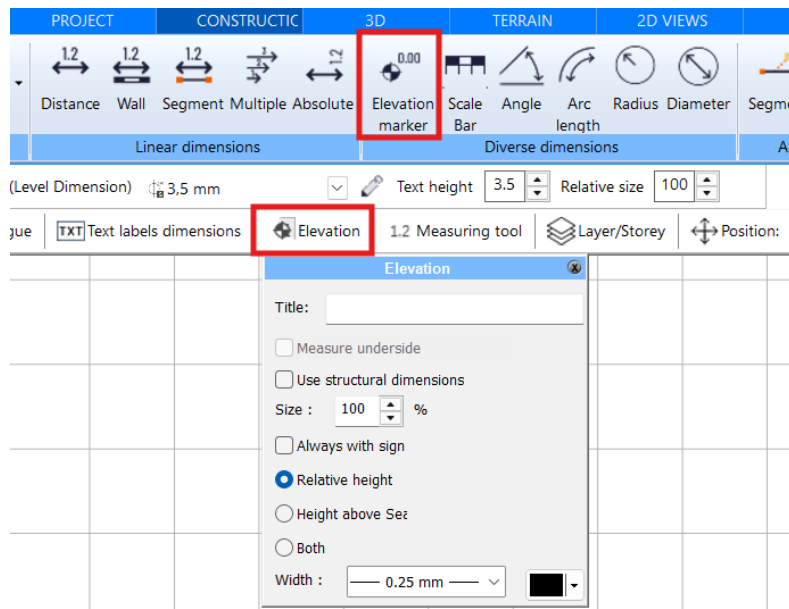

Height dimensions can be placed as shell **dimensions** or **finished dimensions**. The symbols are displayed as filled if the option "Shell **dimensions**" is selected. The **relative size** changes the size of the symbol (circle or triangle).

#### Display in floor plan:



The height node determines the level of the upper edge of the floor or upper edge of the bare ceiling, adjustable in the dialog **Use node|Bare dimensions**.

If the storey parameters are changed, the height dimensions are adjusted accordingly.

The representation, as shown in the example, is often preferred in meters with two or three decimal places.

To do this, select **Dimension** in the dialog :

**Use own unit of measurement dialog: Meters**

**Display: 1.00**

#### Display in the 2D views:

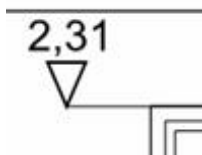

The height coordinate determines the distance to the absolute zero level. If you move the height marker, the measurement is automatically adjusted.

## 19.7 Automatic external dimensioning

A simple example:

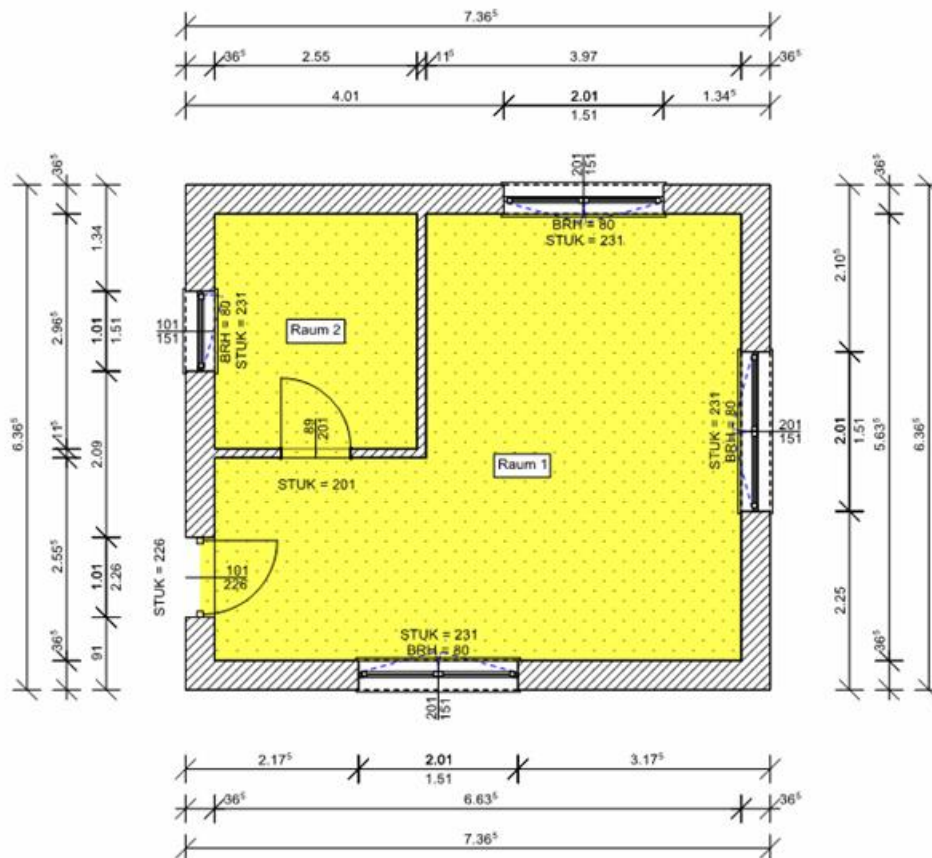

Select the visibility of external dimensions in construction mode in the **Project|External dimensions...** menu.

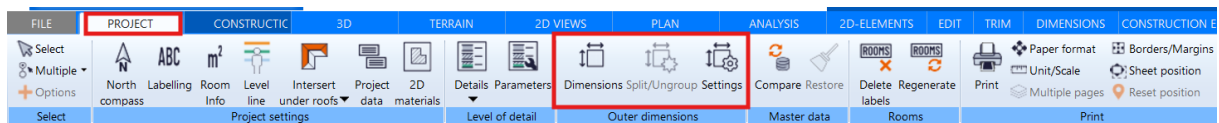

Dimension chains for wall openings, internal dimensions (position of internal walls) and external dimensions are generated automatically.

The settings for external dimensions can be changed. To do this, open the form in the menu with **Project|External dimensions...**

The parameters for the **number of dimensions**, **dimension line** and **auxiliary dimension line** are analogous to the settings for distance dimensions. In addition, the orientation of the dimension chain for non-orthogonal components can be defined in the **External dimensioning** tab.

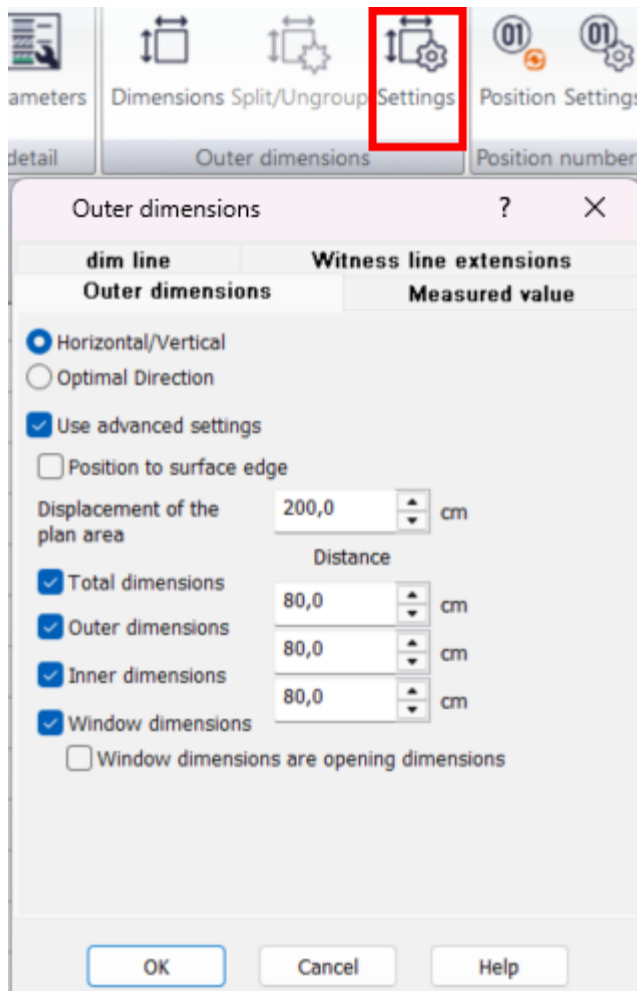

- **Horizontal/Vertical** - Orthogonal dimension chains are always created.
- **Optimal direction** - In the case of sloping external walls, the external dimensioning is displayed parallel to this.

### Resolve external dimensions

In the **Edit** menu, select the entry **Resolve** external dimensioning. The dimension chains now break down into conventional linear distances, which can be edited subsequently. The dimension chains are stored on the **Dimensioning** layer.

Note: if **the external dimensions are displayed and exploded again**, they will be available **twice!**

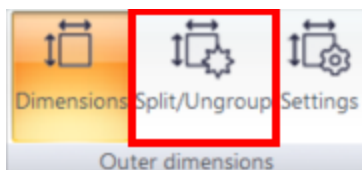

### Format dimension:

Outer dimensions ? X

dim line	Witness line extensions
Outer dimensions	Measured value
Text height : 2,5 mm	
Show: 1.00	Background: [ ]
Zeros : 1.10 -> 1.10, 1.0 -> 1.0	
Text position: Interior	Dimension line
Distance to dimension: 0,5 mm	
<input checked="" type="checkbox"/> Auto-position	
<input checked="" type="checkbox"/> Architectural representation	5
<input type="checkbox"/> Always in cm	
<input type="checkbox"/> Use this unit of measurement:	Centimetre
<input type="checkbox"/> Display unit of measurement	
<input type="checkbox"/> Display decimals as English unit of measurement	

OK Cancel Help

**Options:**

Text height  
Text height  
background

Zeros  
Text position  
Distance to dimension line

Automatic positioning

architect-oriented representation  
always in cm

Use your own unit of measurement:  
Display unit of measurement  
Decimal representation of English units

**Format dimension line:**

Outer dimensions ? X

Outer dimensions	Measured value
dim line	Witness line extensions
Width : Hairline	
Overhang : 2 mm	
Dim. end point : Type : Dash	<input type="checkbox"/> End point fill
Size of end point : 0,5 mm	
Dash width : 0,25 mm	
<input checked="" type="checkbox"/> Colour like measure line	

OK Cancel Help

#### Width (user-defined):

Dicke :  mm

OK Abbrechen Hilfe

#### Options:

Assign color

Overhang

Dimension ends:

Type

Fill ends

Sizes of the ends

Width of the line

Assign color like dimension line/color

#### Format dimension line:

Dicke :  mm

OK Abbrechen Hilfe

**Options:**

Width of the line:

Overhang: in mm:

deviating overhang below: in mm

Assign color as dimension line/user-defined color

## 19.8 Fairs

The various editing tools then appear in the *dialog bar*:

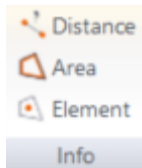

If you only want to measure the distance between two points for your information, you can use the **Measure distance** tool.

If you only want to measure an area for your information, you can use the **Measure area** tool.

If you only want to measure a polygon for your information, you can use the **Measure element** tool.

## 20 Explorer bar

### 20.1 3D objects



#### 20.1.1 General information

##### Inserting objects



Click on the symbol  to open the object catalog:



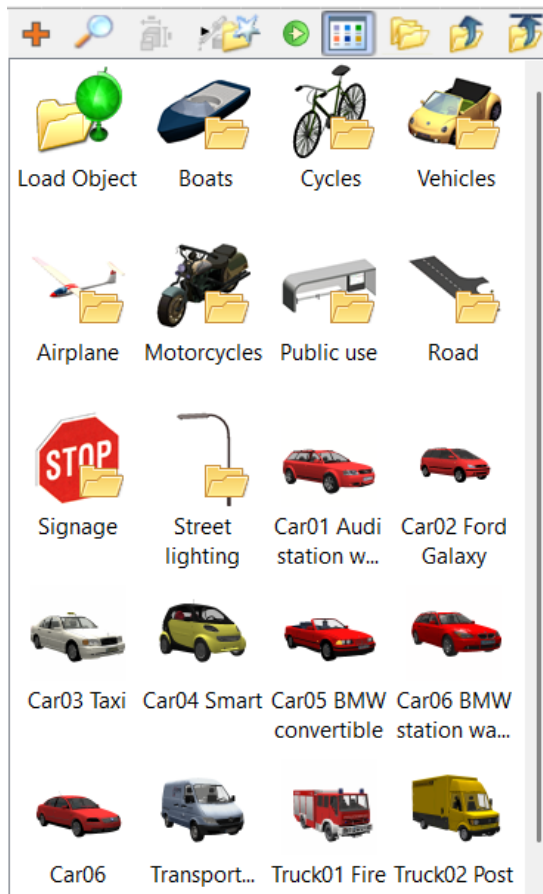

Click on the 3D object in the catalog and drag it into the scene while holding down the left mouse button. As long as you do not release the mouse button, the position of the object can be changed (for more information, see **Moving in 3D**).

To end the insertion of an object (the object is still attached to the cursor), press the **[Esc]** key.

## 20.1.2 Edit

### Moving in 3D

Click on an element and drag it to the new position while holding down the mouse button. The object is moved parallel to the screen plane to the left, right, top or bottom. If you also hold down the right mouse button, the object is moved along the viewing direction.

### Working with handles

If you select a 3D object in 3D mode, a handle is shown on all sides and corner points of the bounding box (the circumscribing cuboid). The cones on the side surfaces are used to rotate around the respective axis, the corner points are used to scale the object.

The entries with handles are not recorded exactly with values, but are made by dragging with the mouse. Exact changes must therefore be made using the **Size and position** properties dialog.

Move the mouse over the handle, the handle is highlighted and move the mouse with the left mouse button pressed. The changes are displayed immediately. For scaling, note the **Maintain proportion** property in the Size and **position** dialog.

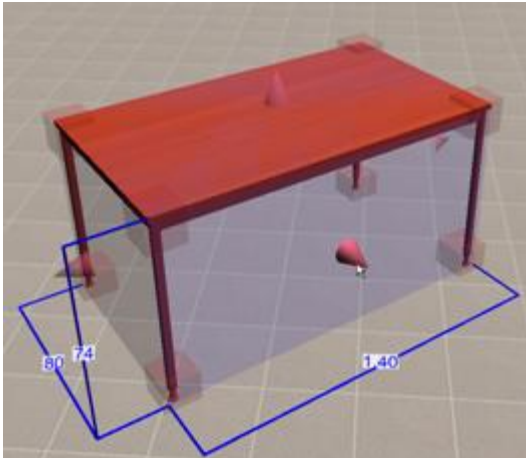

Display 3D object with handles

### 20.1.3 Substitute representation

The representation of a 3D object is automatically determined as a top view of the object in the floor plan view. In the table example, the table legs are not visible.



Table representation with automatically generated substitute representation.

For many objects, this is the best way to obtain a correct representation without additional effort. For more complex requirements, Plan7Architect also supports free substitute representations that can be assigned to the 3D object.

The prerequisite for this is a symbol with the appropriate representation and the correct size. The automatic substitute representation can also be used as the basis for the symbol.

#### Assigning a substitute representation to an object:

For this example, we want to assign a substitute representation to a tree:

- Insert the tree as a 3D object in the floor plan.
- Draw a circle as a substitute representation.
- Save this circle as a symbol (in the **Trees floor plan** catalog ).
- Open the 3D object catalog again and right-click on the tree. Select **Assign 2D replacement representation** in the context menu and select the symbol for the floor plan representation in the dialog that appears).

The visibility of substitute representations can be switched on and off in the **View** menu. Each individual object still has the option in the **3D object** properties dialog to show the substitute representation always/never or as the default (is the same as the **View|2D representation for 3D objects** menu ).

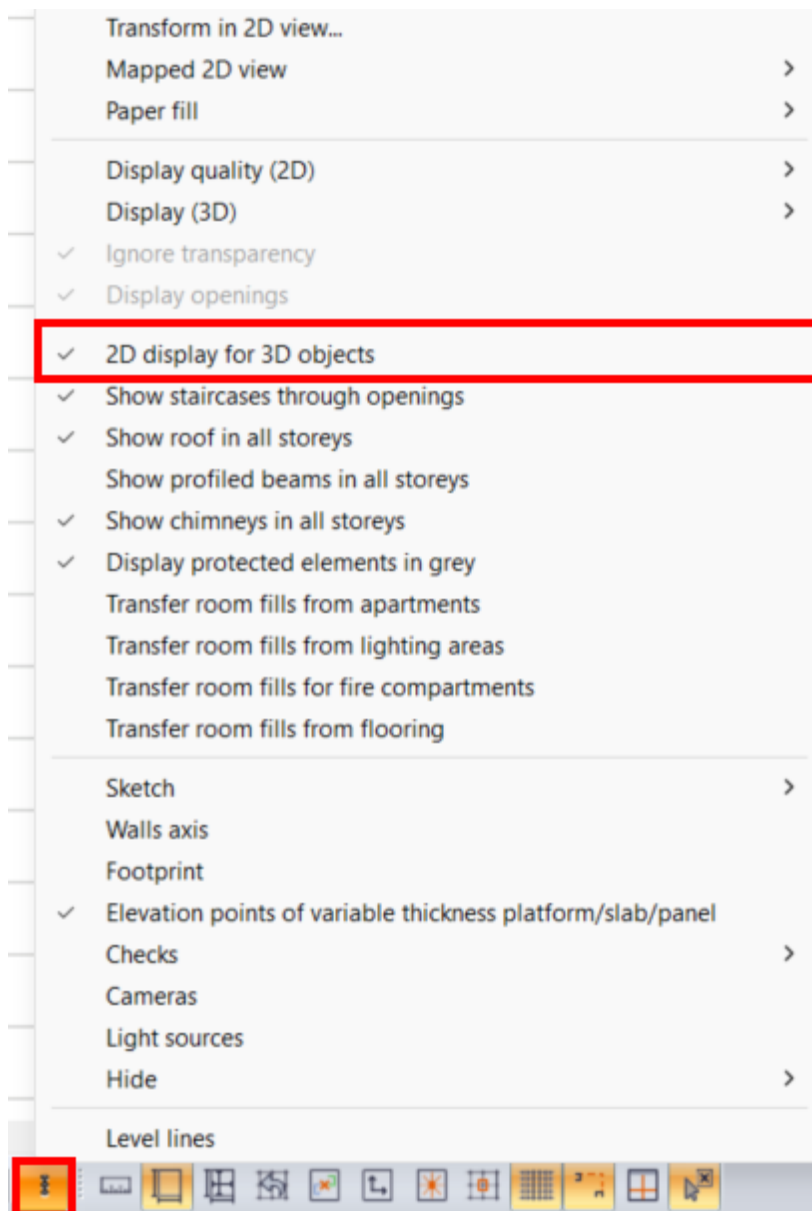

### 20.1.4 Property dialogs



#### Light source

Each 3D element can be used as a light source. To do this, activate the option in this properties dialog. The properties of the light source are covered in [Light sources](#)<sup>[428]</sup> in the **Light** chapter.

#### 3D object

This dialog is used to set when the substitute display of the 3D object is shown.

#### Photovoltaics

#### 2D display

The display of the automatic substitute display can be influenced in the **2D display** properties dialog. The **2D display** properties dialog is described in the *General properties dialogs* chapter.

#### Line endings

The [Line](#)<sup>[142]</sup> endsproperties dialog is described in the General *properties dialogs* chapter.

#### Properties

Further information on the [properties](#)<sup>[145]</sup> can be found in the [General properties dialogs](#)<sup>[134]</sup> chapter.

#### Layer/Storey

Select the layer and the storey for the 3D object. If the storey is changed, the object does not move in height. For more information, see the [Layer/storey](#)<sup>[143]</sup> in the General *properties dialogs* chapter.

#### Size and position

This dialog is described in more detail in [Size/Position](#)<sup>[143]</sup> in the General properties *dialogs* chapter. In contrast to the explanations in this chapter, the angle of rotation around the X, Y and Z axes can also be recorded for 3D objects. For 3D objects, there is also the option to select whether they fall down after being moved or remain at the height of the mouse cursor.

### 20.1.5 Databases

3D objects are saved in databases in Plan7Architect. At startup, all databases with 3D objects are loaded and displayed in the catalog according to the current settings.

In the **Options|Select databases for saving** menu, you can specify the database in which newly saved objects are stored.

By default, this is the **Own objects** database.

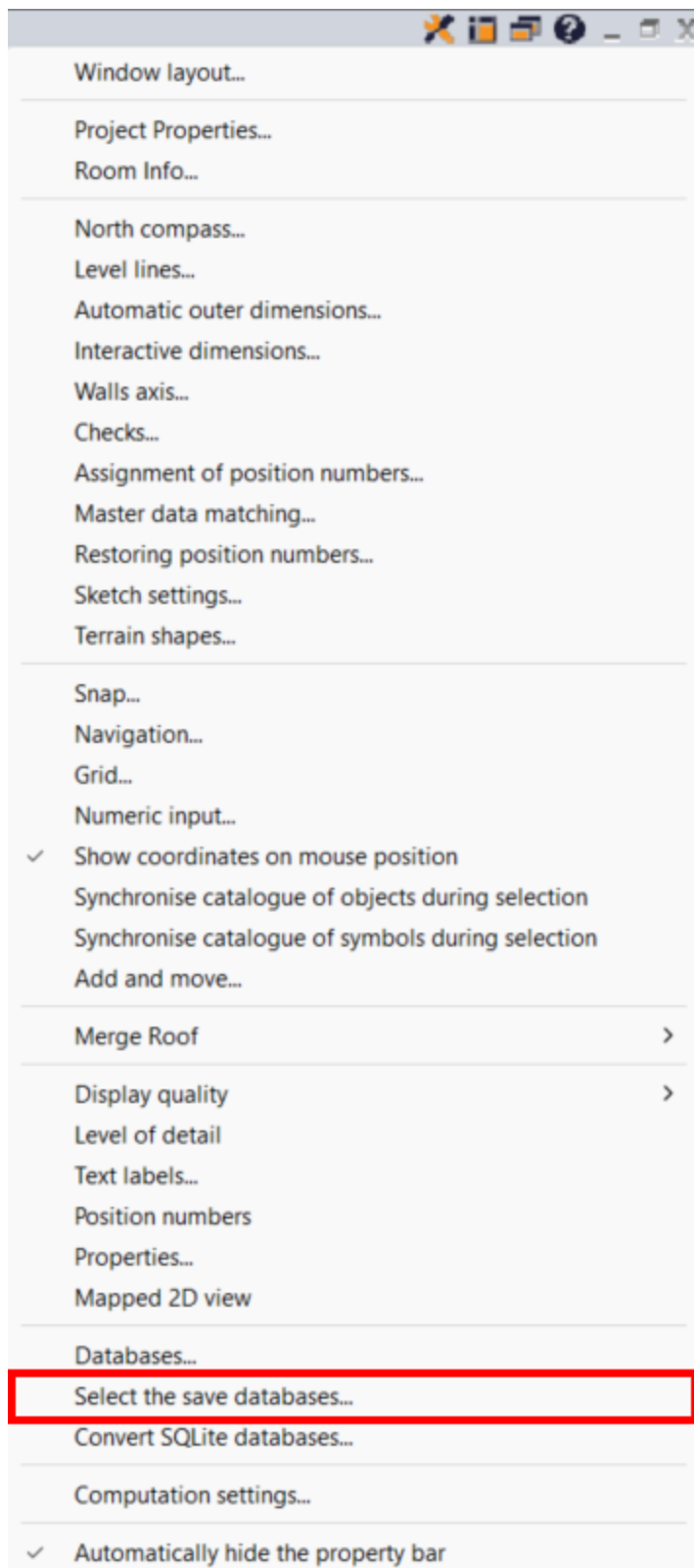

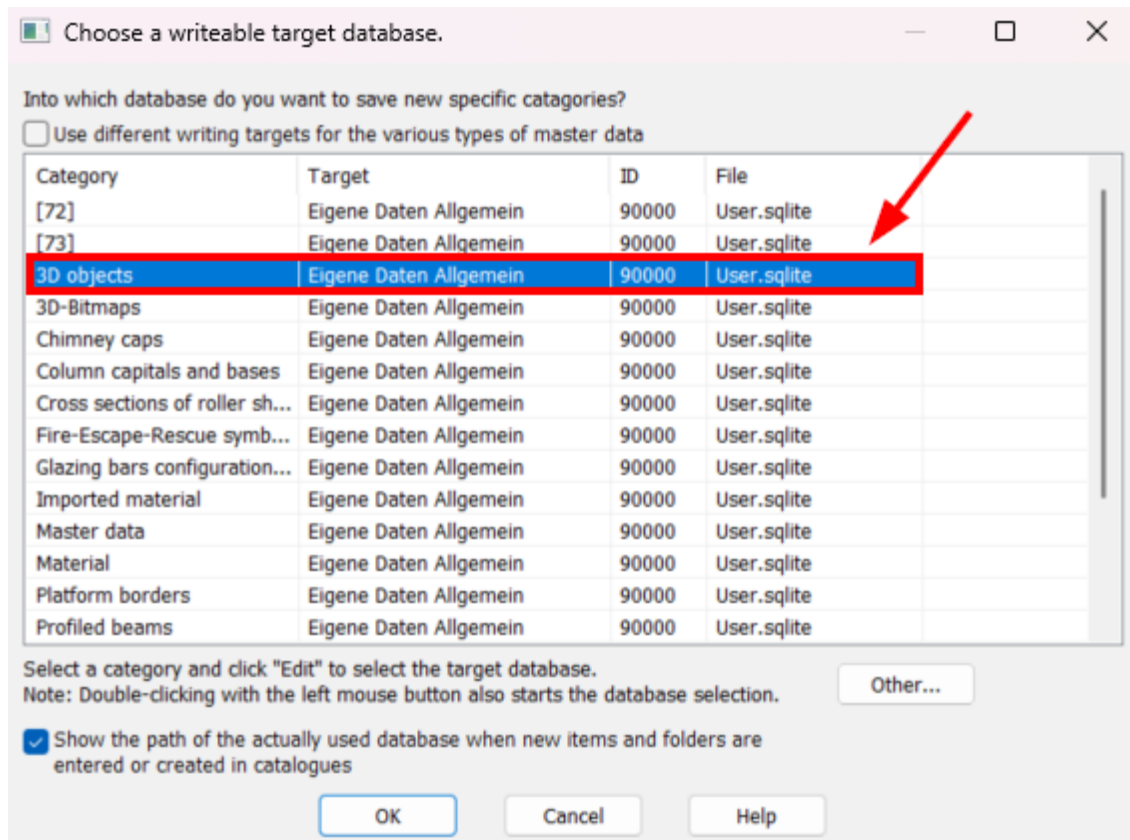

### 20.1.6 Insert and move

In the **Options|Insert and move** menu (accessible from 3D mode), the behavior of the objects can be defined when inserting.

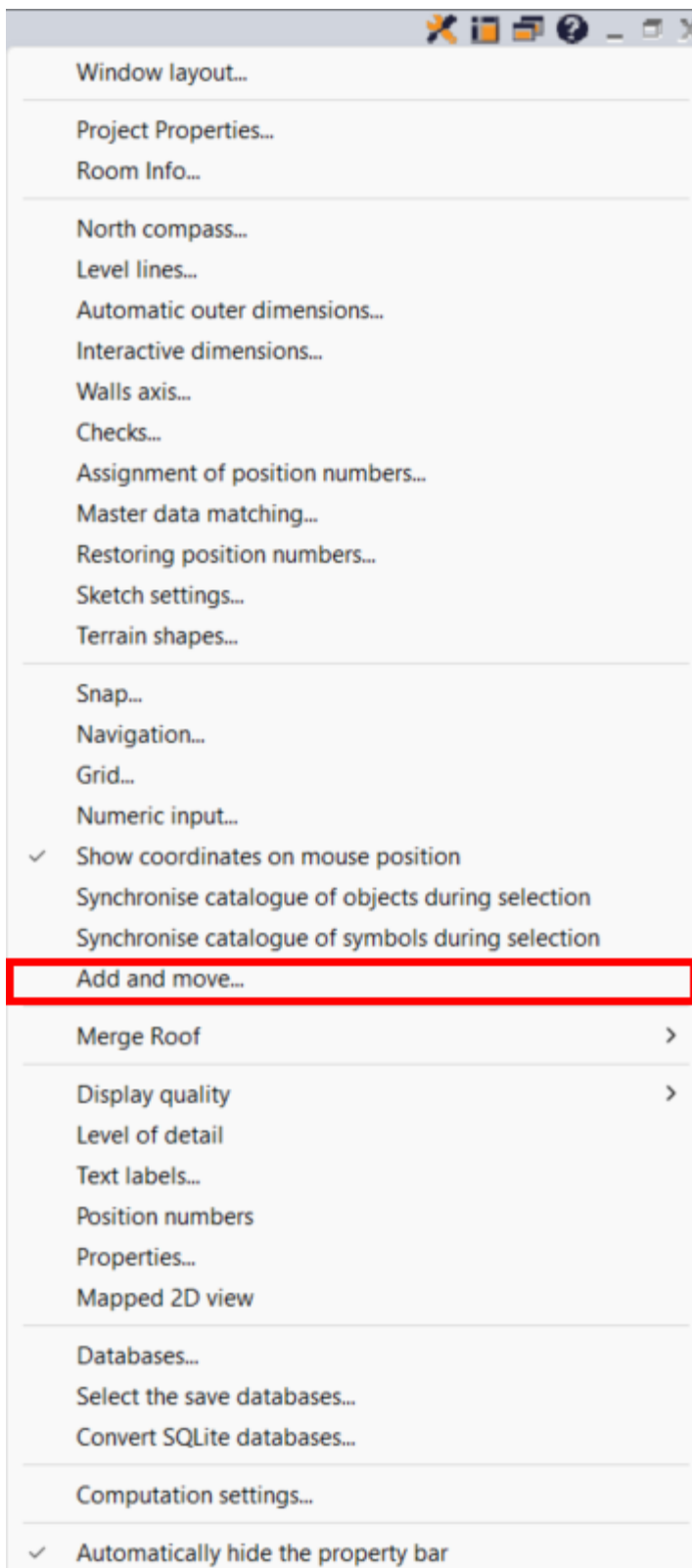

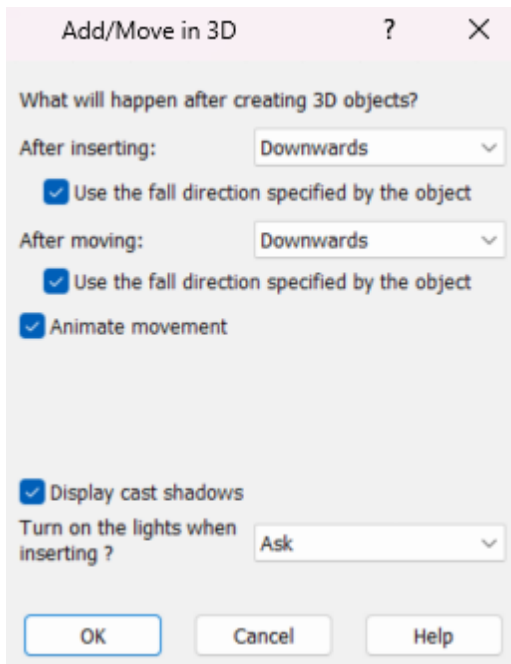

Use this dialog to specify how 3D objects should behave after being inserted from the catalog.

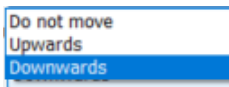

It is recommended that the direction of fall is specified by the object.

## 20.2 Symbols

Symbols are used to provide frequently used drawing parts for reuse. A symbol can consist of all elements that can be drawn in Plan7Architect.

### 20.2.1 Insert

#### Inserting symbols

The button for opening the **symbol catalog** is available in construction mode:

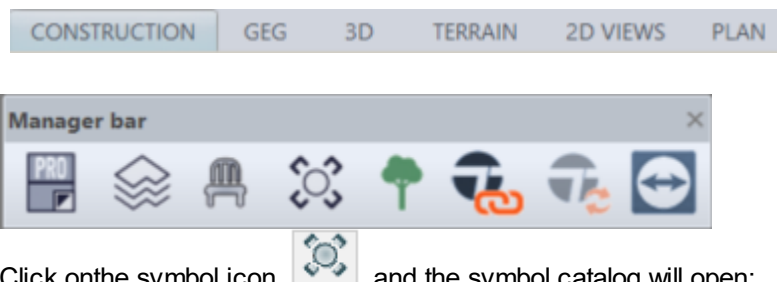

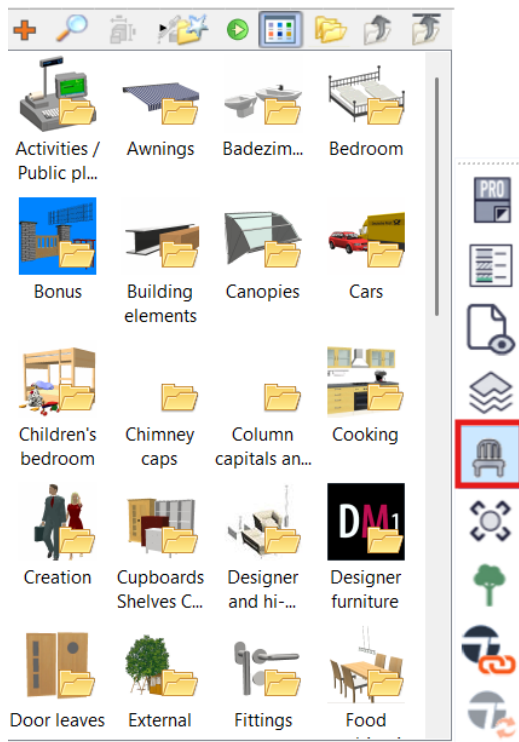

This catalog is designed like an explorer; double-click to access the respective subfolder. If there is no longer a small yellow folder attached to the icon, it is possible to use these icons in the planning.

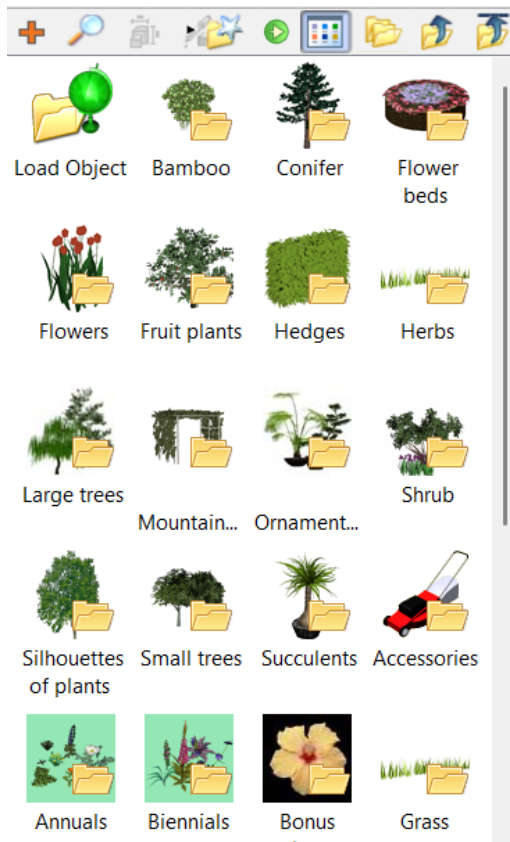

Click on the symbol in the catalog and drag it into the scene by holding down the left mouse button. To end the insertion of a symbol (the symbol is still attached to the cursor), press the **[Esc]** key.

Various properties/size changes can be assigned to the symbol before it is inserted. To do this, activate the red cross for the input options:

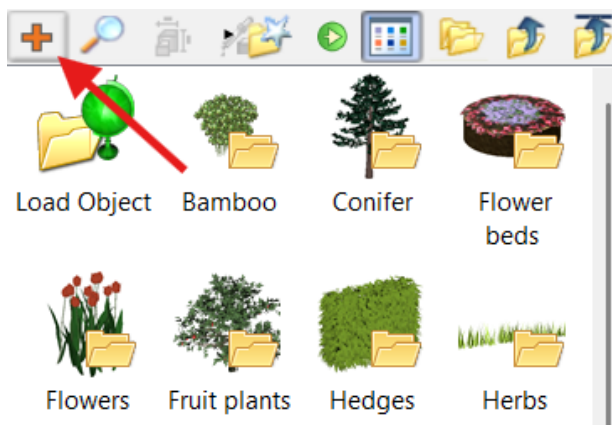

The following dialog appears:

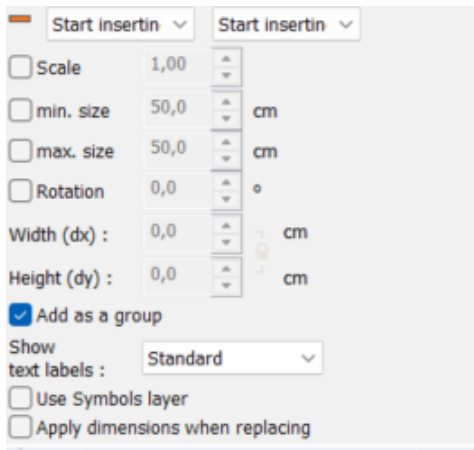

If a symbol is activated in the catalog with the left mouse button, the settings for this symbol can be made before it is placed!

## 20.2.2 Mirror

Mirroring symbols: Go to **Edit** | **Mirror**:

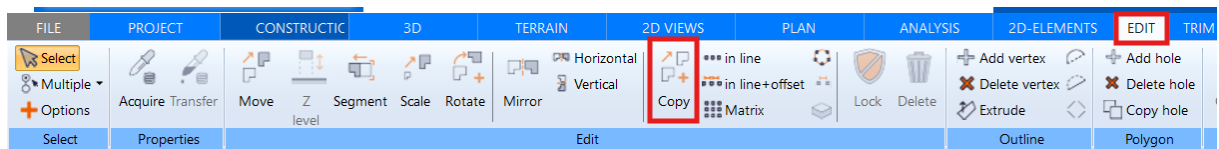

The following options are available here:

Mirror **horizontally**

Mirror **vertically**

Mirror around **any axis**

## 20.2.3 3D designs

The 3D designs are located in the symbol explorer in a separate folder called **Garage Carport Terrace 3D**:

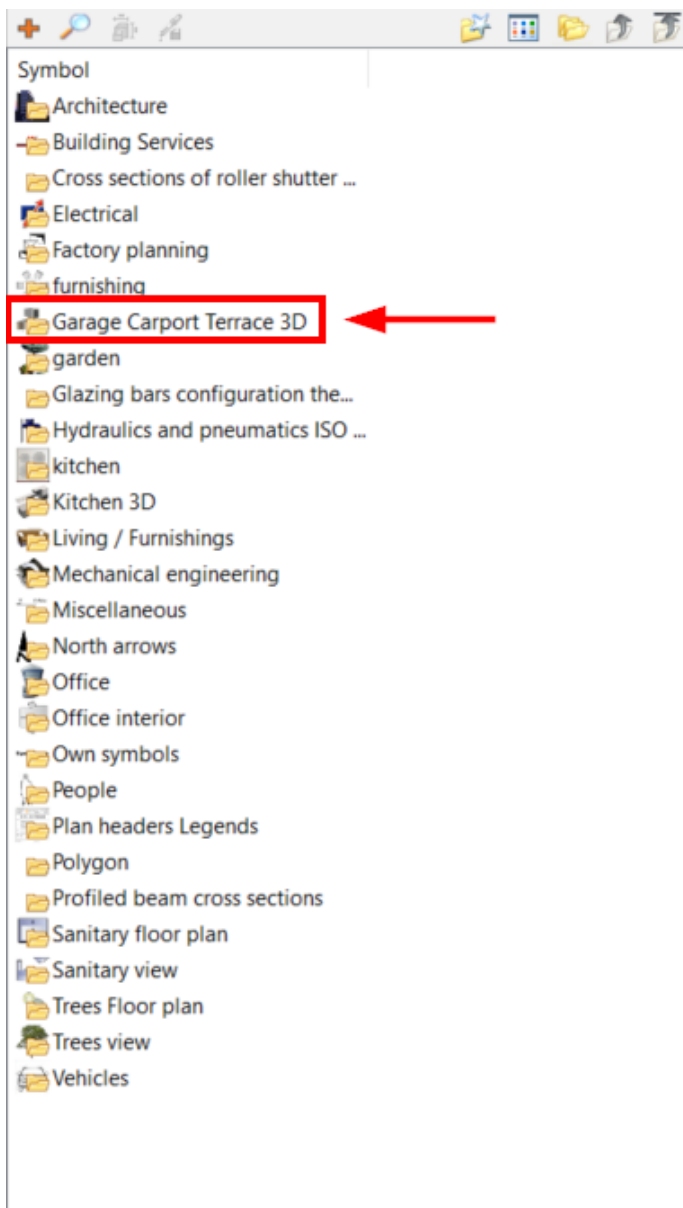

This contains the sub folders **CARPORTS/GARAGES/PERGOLDS/TERRACES**:

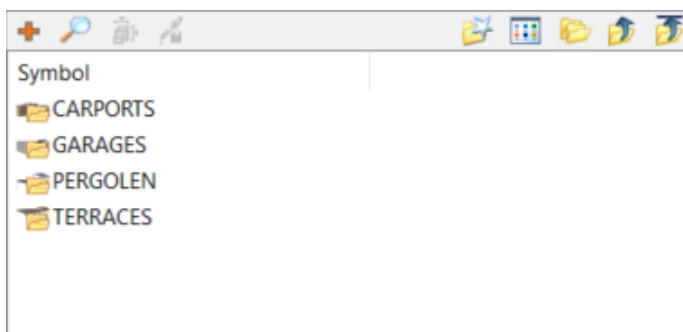

From here, the 3D objects can be dragged into the planning as usual:

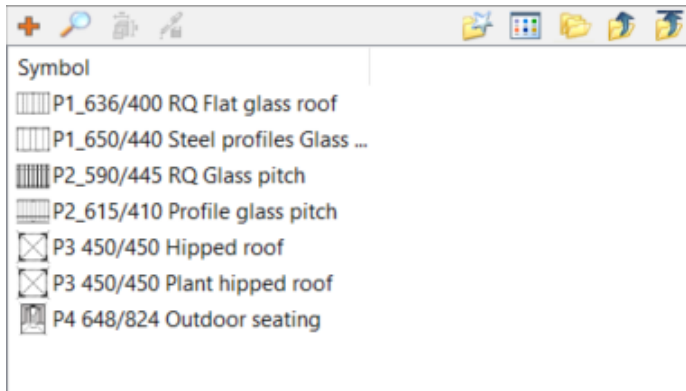

#### 20.2.4 Create and save

You can save your own 2D symbols or 3D elements in the symbol catalog. These are then available for all further planning.

Even extensive groups consisting of several 3D+2D components can be saved there.

Select the elements in the planning and drag the selection into the catalog. A dialog appears in which you can enter the name for the new symbol.

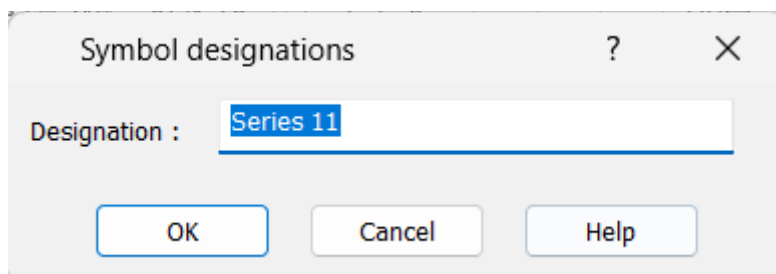

Enter the name for the symbol.

The option ***Adjust to scale when inserting*** is activated to adjust the size of the symbols to the current project scale when inserting them into the planning.

The scale of the drawing from which the symbol was dragged into the catalog is saved in the symbol. If the symbol is placed in another drawing with a different scale, the symbol is enlarged or reduced accordingly. This option should not be used if the content of the symbol is actually fixed in its dimensions, such as a light well, a table or a bay window. Activate this option for plan symbols, labels, etc.

## 20.2.5 Databases

Symbols are stored in databases in Plan7Architect. At startup, all databases with symbols are loaded according to the current settings and displayed in the catalog. In the menu ***Options|Select databases to save...*** menu, you can specify in which database newly saved symbols are to be stored. By default, this is the ***Own symbols*** database.

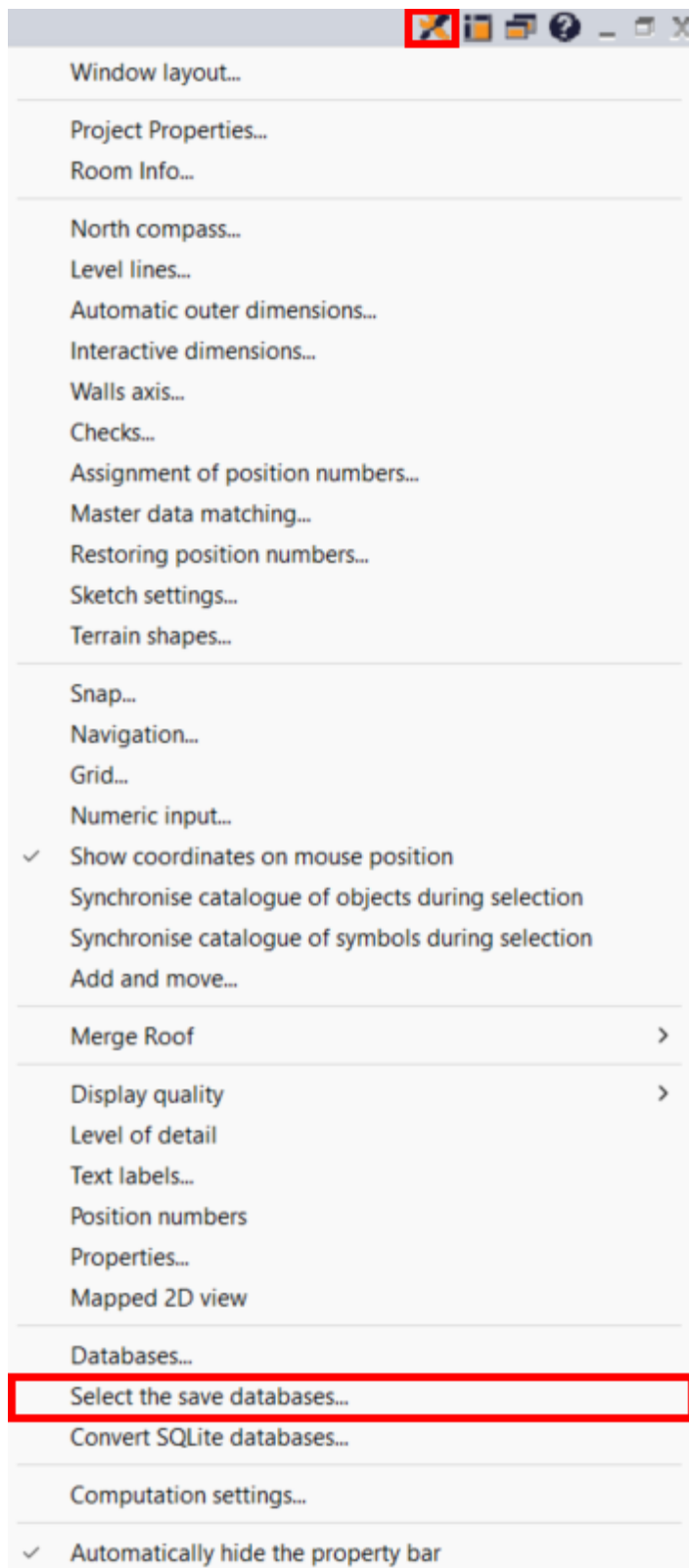

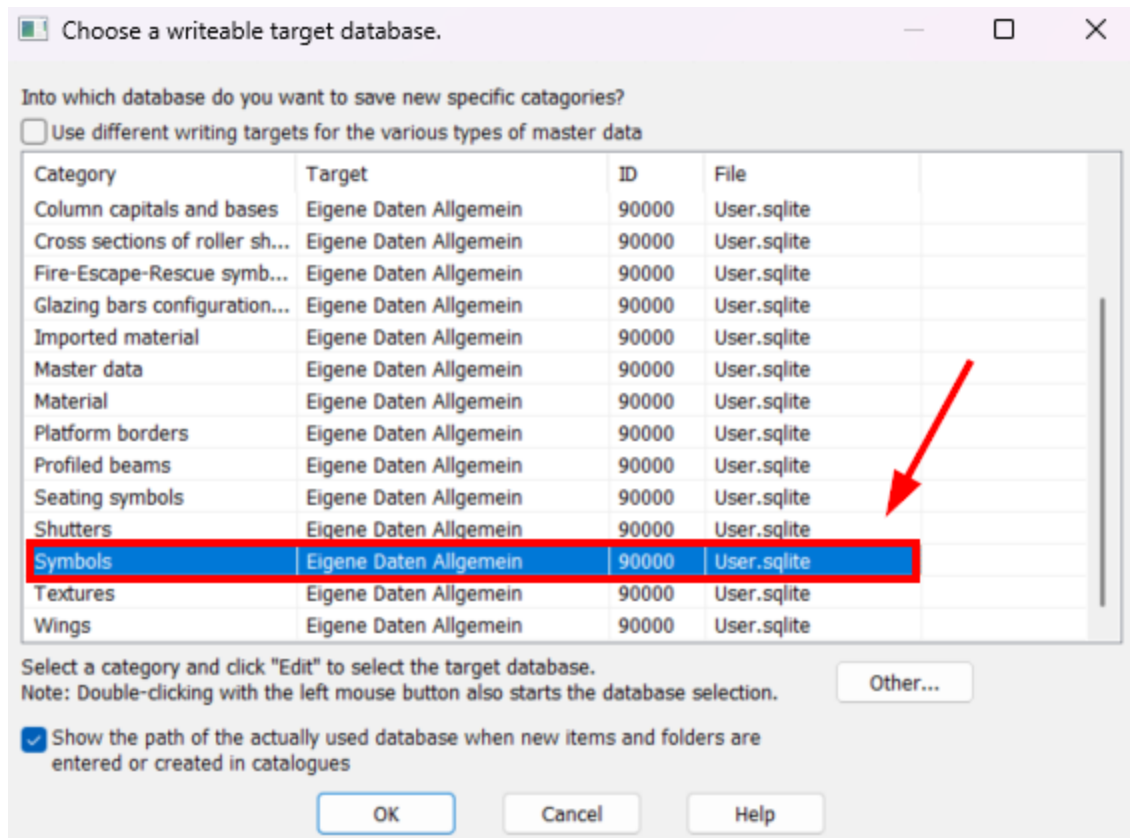

# Index

## - " -

"W"-Button 236

## - \* -

\*.Layer-File 118

## - . -

.Autobackup 68  
 .ifc 34  
 .ifc.ZIP 34  
 .ifcXML 34

## - 2 -

2D representation of roofs 338  
 2D view mode 85  
 2D-Cut 419  
 2D-Drawings 479  
 2D-Elements 479, 520  
 2D-Modi 45  
 2D-Symbols 596  
 2D-View export 510  
 2D-View introduction 479  
 2D-View tips 513  
 2D-Views 479, 481  
 2D-Views of the construction (floor plan) 499

## - 3 -

3D objects, materials, symbols 168  
 3D player Internet object 447  
 3D- Preview 304  
 3D-Constructions 594  
 3D-Cut 419  
 3D-Geometer data 450  
 3D-Mode 408  
 3D-Mode display quality 411  
 3D-Mode perspective 409  
 3D-Models 62

3D-Points 468  
 3D-Scene 64  
 3D-Trapping 420  
 3D-View (persp.) 479

## - A -

a window 192  
 absolute Level 125  
 Absolute mark-up 258  
 Absolute zero value of the planning 208  
 Accurate catching 176  
 Add databases 168  
 Add new layer 231  
 Add plant object 462  
 Additional dimension 319  
 Additional frame part 319  
 Additional point dimensions 323  
 Adjusting the visibility of the projectiles 200  
 Advanced editing window 316  
 Align 87  
 Allow different wall thicknesses 231  
 Altitude 475  
 Altitude above normal zero 471  
 Ambient light (ambient light) 426  
 Angle 227  
 Angle bisector 520  
 Angle dimensioning 575  
 Angle grid 193, 194  
 Angled downstand beam 251  
 Antialiasing 49  
 Anti-clockwise elliptical arc 528  
 Any line 520  
 Arc input types 527  
 Arc through three points 527  
 Arched opening 318  
 Arched wing 308  
 ARCHIKART 68  
 architect-orientated representation 209  
 Arcs 527  
 Area calculation 212  
 Area calculation DIN 277 397  
 Area composition 532  
 Area evaluation according to DIN277 221  
 Area property dialogues 452  
 Areas 83  
 as a roundel (radial) 463  
 as a view of the floor plan 500

as an unobstructed view with the decaying ground plan 499  
 as DXF/DWG 510  
 as file 50  
 as image file 510  
 as Rondell (evenly) 463  
 Ask value 520  
 Assign flat 387  
 Assign flats 403  
 Assign material 433  
 Assign room directly from catalogue 388  
 Assign rooms 402  
 Assign several rooms 402  
 Assign zone 387  
 associative dimensioning 565  
 AutoCAD 45  
 Autodesk 45  
 Automatic backup copy 68  
 Automatic cut-out 372  
 Automatic external dimensioning 577  
 Automatic Frame 310  
 Automatic labelling 561  
 Automatic layer 143  
 Automatic mitre 261  
 Automatic positioning 303  
 Automatic roof contour detection 331  
 Automatically generated list 532  
 Autotext 215, 530  
 Auxiliary element centre line 536  
 Auxiliary element circle over centre point and radius 536  
 Auxiliary element input types 536  
 Auxiliary element polygon course 536  
 Auxiliary element property dialogues 537  
 Auxiliary element rectangle 536  
 Auxiliary element-Any auxiliary line 536  
 Auxiliary element-parallel auxiliary line 536  
 Auxiliary element-rotated rectangle 536  
 Auxiliary elements 536  
 avi file 442

## - B -

Background 416  
 Background brush 434  
 Background image 416  
 Bar (rectangle) 256  
 Bar (rotated rectangle) 256

Bar (vertical) 256  
 Bar 2D representation 262  
 Bar overview bar 257  
 Bar polygon 256  
 Bar position 263  
 Bar position number 263  
 Bar properties 263  
 Bar property dialogues 257  
 Bar surface 263  
 Barrel dormer 347  
 Basic knowledge 83  
 Basic path 168  
 Bat dormer 347  
 Beam alignment 257  
 Beam catalogue 257  
 Beam cross-section 258  
 Beam general 255  
 Beam height 252  
 Beam honouring 261  
 Beam inside 269  
 Beam layer/floor 263  
 Beam Level 263  
 Beam light source 257  
 Beam masses 263  
 Beam material 254  
 Beam position number 254  
 Beam properties 254  
 Beam property dialogues 252  
 Beam size/position 254  
 Beam surface 254  
 Beam thickness 252  
 Beam type 252  
 Beams 132, 251, 269, 272  
 Beams (horizontal) 256  
 Beams catalogue 252  
 Beams overview bar 252  
 Bed input types 461  
 Bed properties dialogues 462  
 Beds 461  
 Bezier curve 523  
 BGF, KGF, BRI, KRI 479  
 Bitmap 60  
 Black contours 414  
 Blankets 265  
 Blended plate 276  
 Blending roofs 346  
 Block references as terrain heights 39  
 Blurring 198, 514

Border object 283  
 Border pages 283, 465  
 Bottom beam contour/filling/hatching 254  
 Bottom beam filling 252  
 Bottom corner 457  
 Boundingbox 584  
 Break the dimensional chain 573  
 Breaking open walls 236  
 Brightness 51  
 Building 103  
 Building animation 442  
 Bump Mapping 430  
 Bumpmap 441  
 Button A 206  
 Button ESC 86

## - C -

cad.autobackup 68  
 CAD-Data exchange 45  
 Cancelling layer protection 114  
 Carport 594  
 Cartesian or polar coordinate values 96  
 CASCADOS - Shortcut keys 185  
 Catalogue - Component templates 150  
 Catalogues Component templates 150  
 Catalogues with component templates 150  
 Catch 176  
 Catch directions 176  
 catch on direction 564  
 catch on directions 176, 193  
 Catch on grid 193, 194  
 Catch options 167  
 Catch points 176  
 Catch radius 180, 194  
 Catching existing points 96  
 Ceiling catalogue 267  
 Ceiling component 265  
 Ceiling contour/filling/hatching 272  
 Ceiling layer/floor 273  
 Ceiling masses 273  
 Ceiling opening 275, 372  
 Ceiling opening overview bar 275  
 Ceiling opening polygon 274  
 Ceiling opening polygon with fixed width 274  
 Ceiling opening spline 274  
 Ceiling opening-rotated rectangle 274  
 Ceiling openings 269, 273

Ceiling openings input types 274  
 Ceiling openings property dialogues 275  
 Ceiling openings-General 274  
 Ceiling overview moulding 267  
 Ceiling panelling 265  
 Ceiling polygon 266  
 Ceiling polygon with fixed width 266  
 Ceiling properties 273  
 Ceiling properties dialogues 267  
 Ceiling recess 274, 275, 372  
 Ceiling size/position 273  
 Ceiling surface 272, 387  
 Ceiling texture 387  
 Ceiling thickness 265  
 Ceiling timber construction 269  
 Ceiling turned rectangle 266  
 Ceiling-ceiling level/structure 268  
 Centre bar 269  
 Centre downstand beam 251  
 Centre line 520  
 Centres 176  
 cexternal player 447  
 Change colours 134  
 Change folder 157  
 Change supports 243  
 Change wall dimensions 568  
 Change Z-height 543  
 Changing the standard.cad 78  
 channel 457  
 Characteristic cornerstones 54  
 Cheek mounting 379  
 Choose which 79  
 Circle and arc dimensions 573  
 Circle over centre and radius 528  
 Circle through three points 528  
 Circle through two opposite points 528  
 Circle/Ellipse 463  
 Circles 528  
 Circles and arcs 527  
 Circles and arcs input types 527  
 Circles and arcs property dialogues 528  
 Circular arc anti-clockwise 527  
 Circular course 140  
 Classic wooden staircase 360  
 Clear view 479  
 Clear view from K mode 479  
 Clearance 372  
 Clearance height 121

- Clockwise arc 527
- Clockwise elliptical arc 528
- Close contour 138, 524
- Collar beam 340
- Collision control 420
- Colour and line thickness 198
- Colours/glow lights 437
- Column contour/filling/hatching 250, 353
- Column Designation 550
- Column layer/floor 250, 353
- Column masses 353
- Column property dialogues 246, 352
- Combine dimension chain 573
- Completion option 231
- Complex roofs 346
- Component template 289
- Component templates 234
- Component templates and mass determination 550
- Component type 150
- Component walls 220
- Components 316
- Concealed edges 414
- Concentric circle 528
- Conclusion 231
- Connected beams 251
- Connected frame elements 310
- Constant colour 140
- Construction bar 83
- Construction levels 520
- Construction mode 85
- Constructive height 121
- Continue working on the last project you worked on 75
- Contour 138
- Contour lines 214
- Contour tools 548
- Contrast 51
- Convert to 2D drawing elements 87
- convert to 2D view 499
- Coordinate input 96
- Coordinate origin 97
- Coordinate system 96
- Coordinate systems 96
- Coordinate tracker 193
- Copy 87, 541, 544
- Copy matrix 547
- Copy Radial 547
- Copy rooms 406
- Copy series 547
- Corner formation 299
- Corner profiles 299
- Corner/mitre design 299
- Cornice boxes 333
- Correct layer assignment 32
- Counter sun 429
- Course of the terrain 450
- Covering 330, 333
- Create a backup copy 68
- Create a new flat 386
- Create a new group 549
- Create a new layer 106
- Create a new project 75
- Create a new storey 121
- Create cut 497
- Create cutting line 483
- Create new 2D view 516
- Create new element 432
- Create new folder 160, 432
- Create new material 432
- Create zone 386
- Creating and saving symbols 596
- Creating the standard.cad 78
- Creation of a new window/window section 319
- cropped view 370
- Crosshairs 180, 193
- Cross-project 150
- Cubemap 416
- Current section 48
- Curtains 326
- Customise 2D view options 200
- Customise 3D view options 200
- Customise the visibility of the layers 200
- Customise visible 2D section 200
- Customise visible 3D section 200
- customised ceilings 265
- Cut 479
- Cut and glued edges 79
- cut open areas 239
- Cut with display above 370
- Cut without display above 370
- Cuts 483
- Cutting height of the roof 338
- Cutting level 370
- Cutting lines 520
- Cutting symbols 485
- Cylindrical background image 416

**- D -**

- Database 170
- Database ID 170
- Databases 150, 168
- Databases for component templates 154
- Day 416
- Day view 428
- Decimal places in the room stamp 399
- Define section 50
- Define the drawing unit 36
- Definition of individual levels at each polygon point 377
- Delaunay-Triangulation 466
- Delete 87
- Delete 2D view 482
- Delete a component template 151
- Delete a layer 109
- Delete a projectile 124
- Delete cutting line 485
- Delete existing shift 231
- Delete flat 386
- Delete folder 160, 432
- Delete material 432
- Delete object 160
- Delete supports 246
- Delete unattached rooms 404
- Delete zone 386
- Delta values 543
- Dependencies between storeys 125
- depending on scale 234
- Depth of detail simple, medium and fine 216
- Design aids 193, 520
- Detail editing of elements 304
- Detail level 216
- Detail levels 370
- Determine direction automatically 231
- Determine gradients automatically 358
- Determine height and position 421
- Determine image file scale 53
- deviating overhang below 562
- Dialogue area composition 532
- Dialogue bar 83
- Dialogue colour selection 136
- Diameter dimension 574
- Die Modi 85
- different level of detail 234
- Diffuse light 427
- Dimension arrow for diameter 575
- Dimension arrow for distances 572
- Dimension arrow for radii 574
- Dimension ends 562
- Dimension guide up to the element 564
- Dimension labelling 561
- Dimension line 558, 562
- Dimension points 558
- Dimensional chain 558
- Dimensional chain for edge 572
- Dimensional chains 572
- Dimensional guidelines 562
- Dimensional tools 573
- dimensionally accurate machining 180
- Dimensioning 520, 558, 564
- Dimensioning catalogue 558
- Dimensioning layer/floor 559
- Dimensioning property dialogues 558
- Dimensioning-dimension number 560
- Dimensioning-Introduction 558
- Dimensioning-size/position 559
- Dimensions 289
- DIN 277 212
- DIN-Exportformat 59
- Directional light source 148
- Disc input types 276
- Display 560
- Display contour 138
- Display coordinates on the mouse pointer 193
- Display folder structure as a tree 157
- Display grid lines 194
- Display hatching 141
- Display matrix 532
- Display of 3D content in 2D views
- Display of 3D content in 2D views 500
- Display quality 197
- Display quality - with bump and reflection map 412
- Dissolve grouping 549
- Dissolving a group 549
- Distance 227
- Distance coordinate 97
- Distance dimensioning with var. direction 564
- Distance dimensioning with variable direction 564
- Distance to the dimension line 560
- Distance value 299
- Dividing line 532
- Division of the editing windows 192

- Division ratio 520
  - dl - Distance and direction 101
  - dl, a - relativ polar 101
  - Do not create unbound spaces 404
  - Door filling 328
  - Door leaf 308
  - Door leaves 328
  - Door with window elements 328
  - Door/window combinations 304
  - Doors 208, 287
  - Door-window combinations 328
  - Dormer catalogue 348
  - Dormer drawing 347
  - Dormer windows 347
  - Dot labelling 475
  - Downsize 174
  - Downstand beam 253
  - downwards (marked view) 516
  - Downwards tapering depression 457
  - Draw a simple wall 224
  - Draw bars 255, 256
  - Draw beam cross-section yourself 259
  - Draw ceilings 266
  - Draw doors 287
  - Draw downstand beam 251
  - Draw fences 464
  - Draw line contours 522
  - Draw paths 460
  - Draw property 454
  - Draw roofs 331
  - Draw rooms 224
  - Draw skylights 348
  - Draw stairs 355
  - Draw supports 241
  - Draw terrain area 452
  - Draw wall 224
  - Draw wall breakthrough 287
  - Draw walls polygonally 224
  - Draw window 287
  - Drawing aids 174
  - Drawing ceiling openings 274
  - Drawing elements 150
  - Drawing Interchange File Format 45
  - Drawing terrain shapes 459
  - Drawing wall dimensions 566
  - Drawing\_Dormers 347
  - Driveways 451
  - Duplicate material 432
  - Duplicate view 516
  - DWG file format 45
  - DWG/DXF Import 35
  - dx, dy - relative Cartesian 99
  - DXF and DWG file format 45
  - DXF file format 45
- E -**
- Eaves edge 340
  - Edge 457
  - Edge beams 129, 132, 269, 272, 274
  - Edging 383
  - Edit a layer 111
  - Edit a storey 125
  - Edit active 2D view 501
  - Edit active projectile 125, 128
  - Edit contours 548
  - Edit cutting line 485
  - Edit existing shift 231
  - Edit flat 386
  - Edit folder 160, 432
  - Edit material 432
  - Edit objects 584
  - Edit plate points 286
  - Edit points 273
  - Edit running line 361
  - Edit selected storey 128
  - Edit staircase polygon 361
  - Edit the current colour 134
  - Edit/mark 174
  - Editing mode for roofs 343
  - Editing the roof sides 342
  - Editing tools 541
  - Editing walls 235
  - Editing window 192
  - Element classification 28
  - Element information 83
  - Element snap points 323
  - Element types 106, 111
  - Ellipse through circumscribing rectangle 528
  - Ellipse through two axes 528
  - Ellipses 528
  - Ellipses and special curves 527
  - End fixed 364
  - End points 176
  - Enlarge 174
  - Enlarge section 174

- Enter two points 564  
 Enter with offset 522  
 Entering coordinates Further examples 102  
 Excerpts 200, 408  
 Exit 364  
 Exit width 358  
 Expansion at the end 258  
 Expenditure 212  
 Explorer 157, 582  
 Explorer - Search 164  
 Export 3DS 64  
 Export 3D-VRML 62  
 Export as panorama 66  
 Export format PDF 60  
 Export IFC file 34  
 Export image files 48  
 Export options 59  
 Export quality 66  
 Export settings 66  
 Export X3D 65  
 Export-3D models 62  
 Exporting DWG/DXF 41  
 Export-Other providers 68  
 Extend 142  
 Extend (G) 555  
 Extend dimension chain 573  
 extend from 176  
 Extend objects 283  
 Extended processing 293, 304  
 Extended terrain shapes 457, 459  
 Extending walls 235, 236  
 Exterior beam 269  
 Exterior window sills 300  
 External dimensions 217, 569  
 External files in the catalogue 160, 432  
 External viewer 28  
 Extrude contour 548  
 Eye point 429
- F -**
- F button 206  
 Facet node 450  
 Facetten 450  
 Facettierung 450  
 Faschen 301  
 Fence polygon 464  
 Fence side 464  
 Fence surround object 465  
 Fences 464  
 Fences property dialogues 465  
 File extension .bak 68  
 File format for import 40  
 File import 40  
 File Import/Export 28  
 File management (load - save - backup) 24  
 Fillets 450  
 Filling/glass 293  
 Filling/glass thickness 293  
 Fillings 140  
 fine 234  
 Finished dimensions 575  
 Fitting 463  
 Fix level 121  
 Fixation buttons 180  
 Fixed directions 176  
 Fixed distance 520  
 Fixed mitre 261  
 Fixed resolution 48  
 Fixed size 48, 258  
 Fixed value 561  
 Flat tool 403  
 Floor 121  
 Floor above the current floor 121  
 Floor above the highest floor 121  
 Floor area 387  
 Floor below the lowest floor 121  
 Floor levels 125  
 Floor selection list 120  
 Floor texture 387  
 Foot mounts 379  
 Forecourts 451  
 Form field 530  
 Form fields 550  
 Format 34  
 Format dimension 577  
 Format dimension aid line 577  
 Format dimension line 577  
 four windows 192  
 Frame 310  
 Frame components 304  
 Frame wideningFrame widening 323  
 Frame width 293  
 Frame/frame 293  
 Frame/sheet thickness 293  
 Frames per second (FPS) 442

Free 2D view 480  
 Free bar 255  
 Free frames 310  
 Free staircase construction 355  
 Free view 482  
 Freehand drawing 198  
 From Estrich 208  
 From-Ceiling 208  
 Front edge of the dormer 347  
 Front face 261  
 Further settings 501

## - G -

Gait 293  
 Garage 594  
 Gear like door 293  
 General information 450  
 General labelling 204  
 general opening 318  
 General platform staircase 355  
 General settings 304  
 General shelf 313  
 General spiral staircase 355  
 General staircase 355  
 general trapezoidal opening 318  
 general trapezoidal wing 308  
 general wing 308  
 Geographical location 428  
 Geometer files 468  
 Geometric data three-dimensional 468  
 Geometry 28  
 Georgian bars and frame components 304, 323  
 Giebel 330  
 Gradient 286  
 Gradients 358  
 Graphic elements 520  
 Graphic elements such as line, polygon, circle 520  
 Graphics card 18  
 Grid 194  
 Grid spacing 194  
 Grid strip 83  
 Grid visibility 193  
 Group labelling 210, 551  
 Grouping 549  
 Groups 549  
 Guide lines 265, 569  
 Gutters 330, 333

Gutters and ridge tiles 333

## - H -

Half arch sash 308  
 Handrail bracket 379  
 Hardware 18  
 Hardware and software requirements CASCADOS 18  
 Hatching 141  
 Hatching parameters 141  
 Hatching pattern 141  
 Heading 532  
 Height changes in 3D 543  
 Height differences 450  
 Height dimensioning in 2D views 510  
 Height dimensions 575  
 Height of the gutters 333  
 Height of the storey 125  
 Height position of ceiling panels 268  
 Height profile 458  
 Help function for defining the drawing unit 36  
 Hide hidden edges 479  
 Hide lines 508  
 Hide view line 508  
 Hide view lines 508  
 High point 286  
 Highlight 427  
 Highlights 456, 475  
 Hill 457  
 Hinged on the outside 293  
 Hip side 330  
 Horizontal mount 383  
 Horizontal/vertical distance dimension 565  
 HSL colour model 136

## - I -

If the originals do not come from the database 71  
 IFC 28  
 IFC file types 28  
 IFC interface 28  
 ifcxml 28  
 ifczip 28  
 Ignore geometry 28  
 Ignore scale 530  
 Illuminated contours 413  
 Illumination 148

Image alignment 52  
 Image capture points 46, 537  
 Image file export from 3D mode 49  
 Image file export from the 2D modes 48  
 Image file snap points 54  
 Image files 45  
 Image processing 46, 537  
 Image size 48  
 Immer 71  
 Import geometer data 468  
 Import horizontal 52  
 Import IFC file 32  
 Import image file 50, 537  
 Import image file button 46  
 Import image file" button 45  
 Import image files 45  
 Import project file 35  
 Import turning 52  
 Importparameter 35  
 in rows 463  
 Incidence of sunlight 203  
 Inclination 342  
 Inclined plate 278  
 Industry Foundation Classes 28  
 Influence of supports on other components 251  
 Influence on stairs from or on other components 374  
 Information bar 83  
 Inner edge beam 132, 269, 272  
 Input options bar 83  
 Input steps 174  
 Insert 3D object 316  
 Insert 3D object as parameter object 316  
 Insert geometer data 468  
 Insert image file into planning 50  
 Inserting and moving objects 589  
 Inserting symbols 591  
 Interface and pull-down menus 83  
 Internal offset 129  
 Internal offset beam 269  
 Internal roof panelling 387  
 International Alliance for Interoperability 28  
 Interpolation 471  
 Intersections 176  
 Introduction 17  
 Isometrics 479  
 Isometry 479, 500

## - J -

Jamb height 342  
 Joist layer/floor 254  
 Joist masses 254

## - K -

Key points 176  
 Keyboard commands 176  
 KeyMark 68

## - L -

l, a - absolute polar 101  
 Labelling 144, 204, 534, 551, 561  
 Labelling of a component 145  
 Landscape 450  
 Landscape representation 471  
 Layer 103, 104, 143  
 Layer and storey visibility 200  
 Layer assignment for drawing elements 112  
 Layer Backed floor plan 50  
 Layer bar 83  
 Layer ceiling tiles 266, 274  
 Layer designation 106  
 Layer im Modell 115  
 Layer management 104  
 Layer plates 276  
 Layer roofs 331  
 Layer set in the layer management 116  
 Layer structure in the model area 115  
 Layer/floor 46  
 Layerlist 115  
 Layers in views and plan layouts 115  
 Layers of groups and their elements 549  
 Layers to be printed 79  
 left mouse button 86  
 Level 121  
 Level lower edge of ceiling 268  
 Level of detail 197, 216, 217, 220, 234  
 Level of detail view 150  
 Level of the joist 253  
 Levels deviating from the storey height 231  
 Light and material 428  
 Light and shadow 426

Light components 426  
 Light sources 428  
 like border 463  
 Line dimensioning 572  
 Line ends 142  
 Line input types 520  
 Line property dialogues 522  
 Line to parallelogram 520  
 Line type of the grid lines 194  
 Linear dimensioning 564  
 Linear dimensioning-editing 573  
 Linear progression 140  
 Lines 520  
 Lines button 520  
 Lintel height 208  
 Listing 532  
 Living space ordinance 397  
 L-knot 221  
 Loading and saving layers 118  
 Loading the camera 442  
 Lot fällen 520  
 Lowering the stairs 274  
 L-shaped room 224  
 L-shaped spiral staircase 355  
 L-shaped staircase with landing 355  
 L-trimming (L) 555

## - M -

Machining wooden structures 340  
 Magnifying glass symbol 164  
 Maintain proportion 143  
 Maintain proportions 138  
 Marking 87, 174  
 Mass determination 28  
 Mass evaluation 550  
 Master data 168  
 Master data synchronisation 218  
 Material 145, 430  
 Material area in rooms 278  
 Material area on walls 278  
 Material for stairs 364  
 Material for timber construction 132, 272  
 Material processing 434  
 Material ranges 276  
 Material scaling/moving/rotating 434  
 Material settings 436  
 Materiaexplorer 430

Materiaexplorer searches 433  
 Maximum extension 176  
 Maximum size 59  
 Measure arc length 573  
 Measure area 581  
 Measure distance 36, 421, 581  
 Measure polygon 581  
 Measuring in 3D mode 421  
 Measuring tools 581  
 Menü Layer 104  
 Metadata 28  
 Metal staircase (steps only) 355  
 Middle extension 198, 514  
 Mirror axis 87  
 Mirrorin 87, 541  
 Mirroring (i) 546  
 Mirroring symbols 594  
 Mittlere Amplitude 198, 514  
 Mode plans 85  
 Modus 3D 85  
 Modus EnEV 85  
 Moonlight 429  
 Mounting direction 289  
 Mouse operation 86  
 Move 541  
 Move component templates to another directory 153  
 Move cutting line 485  
 Move folder 160, 432  
 Move material 432  
 Move object 160  
 Move pivot point 174  
 Move roof 333  
 Move special points 174  
 Move supports 244  
 Move windows, doors, wall openings 174  
 Moving in 3D 584  
 Moving walls 236  
 Multiple copy 87  
 Multiple dimensioning 572  
 Muster 138  
 Muster opak 140

## - N -

Navigation in 3D mode 408  
 Never 71  
 New 2D view 481

New with template 78  
 Night 416  
 Night vision 428  
 Niveaus 231  
 No mitre 261  
 Non-orthogonal walls 198  
 North arrow 203  
 North direction 203  
 Not cut 370  
 Nuances 49  
 Number of catch points 54  
 Numerical input 227

## - O -

Object centre point 176  
 Object databasesObject databases 587  
 Object explorer 157  
 Object property dialogues 586  
 Object structures 304  
 Objects 316, 582  
 Objects-General 582  
 offset cut 483  
 on both sides 562  
 Online dimension options 165  
 Online dimension settings 165  
 Online dimensioning 180  
 Online dimensions 180, 193  
 Opacity 437  
 Open an existing project for editing 75  
 open at the top/bottom 395  
 Open file 40  
 Open or import 40  
 Open view 516  
 Opening contour 274  
 Operating point 98, 193  
 Optimise drawing (image) 51  
 Option "Calculate flat rate" 550  
 Options for wall axles 223  
 Options/Program settings dialogue 75  
 Options/Save dialogue 68  
 Organise 87  
 Orientation of the bar 263  
 Original size 258  
 Output PDF 59  
 Overhang of the roller shutter 300  
 Overhang on the gable ends 340  
 Oversampling 49, 442

Overview 479  
 Overview of terrain shapes 457  
 Overview of wall openings 286  
 Own databases 168

## - P -

Pan with the mouse (2D mode) 176  
 Pan with the mouse (3D mode) 176  
 Panel edging 283  
 Panel processing 286  
 Panel surface 282  
 Panelled door 308  
 Paper filling 197  
 Paper formats.ini 79  
 Paper size and printing 512  
 Parallel 3D view 479  
 Parallel downstand beam 251  
 Parallel line 520  
 Parallel to a line 520  
 Parameters of a component 150  
 Parameters of the roof 332  
 Parapet at floor level 300  
 Parapet height 208  
 Pass on "command" 71  
 Path properties 461  
 Paths 459  
 Pattern transparent 140  
 PDF Export 59  
 PDF Import 55  
 PDF Import/Export 55  
 PDF with vectors 60  
 Performance 364  
 Pergola 594  
 Period length 198, 514  
 Perpendicular points 176  
 Perspective 500  
 Perspectives 479  
 Phix 261  
 Phiy 261  
 Pick up colour 134  
 Picture quality 442  
 Pictures 520, 537  
 Piece by piece 463  
 Pitch height 364  
 Pixel files 45  
 Place 287  
 Place on the sheet 87

- Placing objects at the window 326  
Planning heads 550  
Planting object 463  
Planting objects 462  
Plate 276, 278  
Plate catalogue 277  
Plate polygon with fixed width 276  
Plate property dialogues 277  
Plate rectangle 276  
Plate spline 276  
Plate with cut-outs 278  
Plateau 457  
Plate-polygon 276  
Plates 276  
Plate-turned rectangle 276  
Platform attachment 379  
plus body thickness 131  
Point light source 148  
Pointed dormer 347  
Polar coordinate direction 97  
Polygon 523  
Polygon freehand line 523  
Polygon input types 523  
Polygon N-corner 523  
Polygon property dialogues 524  
Polygon rectangle 523  
Polygon supports 240  
Polygon supports:Move points 243  
Polygon with fixed width 523  
Polygonal supports 240, 241  
Polygonal-general spline 523  
Polygon-rotated rectangle 523  
Polygons 522  
Position 143  
Position bar 83  
Position in the ceiling 129, 269  
Position of the sun 203  
Position sheet 197, 512  
Positioning the absolute zero point 98  
Positioning the operating point 98  
Positions of the dimension chains 217  
PositionsNr 144  
Präfixe 206  
Presentation without CASCADOS 447  
Preview 51  
Primary site 471, 474  
Print 79  
Print as PDF 59  
Printable area 79  
Printout of the 3D view 79  
Programm 68  
Programme interface 83  
Programme start 75  
Project 203  
Project file 215  
Project labelling 204  
Project properties 215  
Project scale 50, 197  
Project view 479  
projected site 471, 474  
Projectile type 121  
Project-related properties 203  
Properties dialogue Light source 148  
Properties dialogue Possition number (PosNr) 147  
Properties dialogue Room data 386  
Properties dialogue Wall 224  
Properties dialogue: downstand beam 251  
Properties of a component 145  
Properties of the cutting line 484  
Properties of the sections and free views 486  
Property 450, 453  
Property bar 83  
Property dialogues for walls 230  
Property dialogues-Property 454  
Proportionen Bestandteile virtuelle Wand 238  
Protect components 87  
Protected layers 114  
Protected storeys 127  
Protrusion 223, 330, 562  
Pull in angled wall 224  
Pull in centre wall 224  
Pull in parallel wall 224  
Pull in vertical wall 224  
Pull up area 174  
Purlin 334
- Q -**
- Q and E buttons 222
- R -**
- Radial course 140  
Radius dimensioning 574  
Rafter heads 340

- rafters 330
- Railing (open/closed polygon) 376
- Railing (rectangle) 376
- Railing (rotated rectangle) 376
- Railing 2D representation 385
- Railing button 375
- Railing catalogue 376
- Railing contour 385
- Railing dimensions 386
- Railing drawing 375
- Railing filling 383
- Railing general 377
- Railing handrail 383
- Railing input types 376
- Railing layer/floor 386
- Railing materials 385
- Railing position number (PosNr) 386
- Railing post 379
- Railing properties 386
- Railing property dialogues 376
- Railing size and position 386
- Railings 364, 375
- Ramp 457
- Rand 532
- random 463
- randomly distributed (concentrated) 463
- randomly distributed (evenly) 463
- Raw ceiling 121
- Read PDF 55
- Reagal floor 313
- Recalculate view 516
- Recess 276, 372
- Recesses 287, 318
- Recorder 442
- Rectangle 463
- Rectangular ceiling 266
- Rectangular ceiling opening 274
- Rectangular opening 318
- Rectangular or round supports 240
- Rectangular room 224
- Rectangular sash 308
- Rectangular shelf 313
- Rectangular support 241
- Reference axis 222, 300
- Reference constant 253
- Reference floor 532
- Reference point 143
- References of objects and materials 71
- Reflection 438
- Reflexionsmap 441
- Reflexionsmaps 430
- Rejuvenation 312
- Relative mark-up 258
- Reload drawing (image) 50
- Remove 2D view 482
- Remove databases 168
- Remove multiple storeys 124
- Remove view 516
- Rename a layer 111
- Rename zone 386
- Representation in floor plan 220
- Representation of groups 549
- Representation of the axis 223
- Reset sheet position 197
- Resolution 59
- Resolve external dimensioning 577
- Reuse 150
- Review assistant 198
- RGB colour model 136
- Ridge 454, 456
- Ridge height 342
- Ridge purlin 340
- Ridge stones 333
- Ridge tile 330
- right mouse button 86
- Roof 333
- Roof area 330
- Roof dormer infill/hatching/contour 348
- Roof dormer property dialogues 348
- Roof edges of the covering 333
- Roof editing mode 341
- Roof filling/hatching/contour 341
- Roof identification 330
- Roof in the attic 331
- Roof input types 331
- Roof on the current floor 331
- Roof openings 343
- Roof openings and roof side extensions 343
- Roof part 346
- Roof pitch 330
- Roof polygon 330, 331
- Roof polygon with fixed width 331
- Roof processing functions 341
- Roof properties dialogues 332
- Roof rectangle 331
- Roof side 334

Roof side type 330  
Roof timbers 340  
Roof towing 343  
Roof window component 351  
Roof window lettering 212  
Roof windows 348  
Roofs 330  
Roofs catalogue 332  
Roofs-General 333  
Roof-turned rectangle 331  
Room contour 393  
Room contour lines 400  
Room data 386  
Room info 212, 397  
Room labelling 206, 212, 390  
Room levels 395  
Room number 532  
Room outside 388  
Room property dialogues 387  
Room rounding 399  
Room stamp 206, 390, 396  
Room tool 402  
Room with a head start 224  
Room with alcove 224  
Room with bay window 224  
Room with slope 224  
Room zone 532  
Room-room data 388  
Rooms 387  
Rooms catalogue 388  
Rooms-General 387  
Rooms-Materials 394  
Rotate coordinate system 102  
Rotate grid direction 193  
Rotate working direction 102, 193  
Rotation 143, 194  
Rotation angle of the beam 263  
Rotation angle of the labelling 551  
Round off edges 258  
Round opening 318  
Round supports 240, 241  
Round wall 224  
Round wing 308  
Rounding 212  
Rounding accuracy 212, 397  
Routes 541  
Routes (S) 544  
Rows or rings 463

Ruler 83  
Rungs 293, 304, 312

## - S -

Saddle dormer 347  
Save active layer 118  
Save all elements in the file 71  
Save current values 152  
Save new component template 150  
Save object 160  
Save on demand 68  
Save PDF 59  
Saving objects and textures 71  
Scale 512  
Scale-dependent detailing 217  
Scaling the image to the project scale 50  
Scanned templates 52  
Scanner 50  
Scan-Wizard 50  
Screen resolution 174  
Screen scale 217  
Screen section 200  
Scroll wheel 86  
Scrolled zoom 408  
Scrollrad Drehen 408  
Search databases 168  
Search paths 160  
Sectional view 370  
Select databases for saving 154, 170  
Select further elements 174  
Select individual element 174  
Select material 437  
Selection from the colour chart 134  
Selection mode 174  
Selection of elements 174  
Selektion 174  
Self-intersection 138  
Self-luminous 428  
Semi-arched opening 318  
Set image quality 49  
Set resolution 49  
Set time 428  
Several dimensions as a dimensional chain 564  
several pages 512  
Shaded floor plan 500  
Shaded view 500  
Shading elements on the window 294

- Shading with edges 415
- Shadow brush 434
- Sheet format 79, 197
- Shelf side 313
- Shelf's 313
- Shell dimensions 575
- Short keys 197
- Shortening walls 235
- Show area decomposition 206
- Show borders 197, 512
- Show everything 176
- Show folder 157
- Show headers/footers 532
- Show hidden view line again 508
- Show hidden view lines again 508
- Show houses 78
- Show title 532
- Show window and door height 560
- Show wood construction/exclusive 129
- Shutter box 294
- Sightseeing flight 442
- simple 234
- Simple door 308
- Simple downstand beam 251
- Simple terrain shapes 455
- Simply textured 413
- Simulate the course of the day 428
- Single-colour background 416
- single-line 212
- Size 143
- Size/position 46
- Sketch 198, 514
- Sketch settings 198, 514
- Skylight 208
- Skylight catalogue 349
- Skylight overview bar 349
- Slab layer/storey Contour/fill/hatching Size/position 285
- Slider 54
- Slope 454
- Sloping roofSloping roof 330
- Sloping walls 198
- Smoothing the edges 49
- Solibri Model Viewer 28
- Solid staircase (underpinned) 355
- Solid staircase underpinned 360
- Solid staircase with covering 360
- Sort ascending 516
- Sort descending 516
- Sort rooms 532
- Space filling/hatching 394
- Sparrenpaar 340
- Special catch points 143
- Special dimensional characteristics 209
- Spherical background image 416
- Spiral staircase 355
- Spline ceiling 266
- Spotlight 148
- Sprout picture 312
- S-shaped room 224
- Stair mould 358
- Staircase 2D representation 370
- Staircase calculation 364
- Staircase catalogue 358
- Staircase design 360
- Staircase dimensions 358
- Staircase display 370
- Staircase effect 49
- Staircase general 355
- Staircase labelling 209, 373
- Staircase layer Storey 374
- Staircase machining 361
- Staircase outline 372
- Staircase overview bar 358
- Staircase position number 373
- Staircase properties 373
- Staircase property dialogues 358
- Staircase size and position 374
- stairs 354
- Stairs visible through holes 126
- Standard bar 83
- Standard materials 234
- standard.cad 24, 203
- Standards 153
- Start 364
- Start fixed 364
- Start without a project 75
- Starting width 358
- Steps only 360
- Still images 442
- stored 2D view 197
- Storey 143
- Storey height 121
- Storey management 111, 119
- Storey names 120
- Storeys 103, 119

- Storeys menu 121
  - straight cut 483
  - Straight frame element 310
  - Straight staircase 355
  - Stretching 541, 545
  - STRG-Button 124
  - Stucco element 326
  - Subfolder 582
  - Subsequent processing of the terrain 475
  - Substitute representation 585
  - Summary of the settings for loading and saving 73
  - Sunlight 429
  - Support dimensions/level 247, 352
  - Support feet 247
  - Support heads 247
  - Support material 250, 353
  - Support polygon with fixed width 241
  - Support position number 353
  - Support properties 250, 353
  - Support rotated rectangle 241
  - Support size/position 251, 354
  - Support Spline 241
  - Support surface 250, 353
  - Supported geometry elements 45
  - Supports 240
  - Supports catalogue 246, 352
  - Supports-General 240
  - Surface 145, 234
  - Surveying office 450
  - Suspension 121, 268
  - Switching the ruler on/off 193
  - Symbole 591
  - Symbols databases 597
- T -**
- Tangent to circle 520
  - Tangent to two circles 520
  - Tangential circle to two circles 528
  - Tap - Transfer 433
  - Tapping roof side properties 342
  - Template 51
  - Template file 78
  - Templates 24, 150
  - Terrain 450
  - Terrain area 451
  - Terrain areas 450
  - Terrain elevation labelling 211
  - Terrain form 450
  - Terrain heights 39
  - Terrain import 39
  - Terrain mode 85, 450
  - Terrain modelling 466, 471
  - Terrain modelling - General 466
  - Terrain representation 476
  - Terrain settings 471
  - Terrain shapes 455, 476
  - Terrain types 450, 474
  - Terrasse 347, 594
  - Text centred 530
  - Text formatting options 531
  - Text height 560
  - Text input 530
  - Text left-aligned 530
  - Text rectangle 531
  - Text right-aligned 530
  - Textposition 560
  - Texts 520, 529
  - Texts in groups 550
  - Texture 430, 439
  - Texture filter 439
  - Texture Mapping 430
  - Texture of the Mask 439
  - Texture shift 174
  - Textures 132
  - The Cartesian coordinate system 96
  - The colour selection dialogue 136
  - The content area 160, 432
  - The polar coordinate system 97
  - The structure of CASCADOS projects 103
  - The surface 83
  - Thickness 312
  - Thickness of the virtual wall 238
  - three windows 192
  - Tile height 141
  - Tile image 140
  - Tile size 138, 141
  - Timber construction cross-sections 131, 270
  - Time course 442
  - Time-dependent view 203, 428
  - To the beginning (marked view) 516
  - To the end (marked view) 516
  - Tolerances 198, 563
  - Tool options for the selection 174
  - Toolbox 227
  - Top corner 457

Top edge of the floor 125  
 Total 532  
 Touch point 236  
 Trailing dormer 347  
 Transfer properties 540  
 Transparency 136  
 Trapezoidal dormer 347  
 Trapezoidal opening 318  
 Trapezoidal wing 308  
 Triangular opening 318  
 Triangular window 308  
 Trimming supports under roofs 245  
 Trimming tools 555  
 true to scale 50  
 T-trimming (multiple) 555  
 T-trimming (T) 555  
 Turn step edges 361  
 Turning 87, 541  
 Turning (D) 545  
 Two colour ramps 416  
 two lines 212  
 Two windows (horizontal division) 192  
 Two windows (vertical division) 192  
 Two-stage processing concept 286

## - U -

Unbound rooms 87, 404  
 Underside of the roof 333  
 Unit of measurement 197  
 Unit selection box 36  
 Unravelling (A) 556  
 Untexturiert 413  
 Update 2D view 508  
 upwards (marked view) 516  
 Upwards tapered slope 457  
 Usable area type/enclosure type 532  
 Use 198, 514  
 Use as a template 532  
 Use as standard 153  
 Use dimension points 564  
 Use fixed value 564  
 Use materials 433  
 Use standard font 206  
 U-shaped spiral staircase 355  
 U-shaped staircase with landing 355

## - V -

Variable 416  
 Variable directions 176  
 Variable plaster thickness per wall segment 221  
 Vector graphics 60  
 Vector import 60  
 Version number 45  
 Vertical beam 251  
 Vertical import 52  
 Vertical surfaces 475  
 Video 442  
 View 197, 479  
 View bar 83  
 View management settings 516  
 Viewer's point of view 429  
 Views 481  
 Virtual rooms 236  
 Virtual wall contour 238  
 Virtual wall layer/floor 239  
 Virtual wall levels 238  
 Virtual wall position number 239  
 Virtual wall properties 239  
 Virtual wall property dialogues 237  
 Virtual wall size/position 239  
 Virtual walls 236  
 Virtual walls catalogue 237  
 Virtual walls: tips 239  
 Virtual walls-wall 238  
 Visibility in planning 197  
 Visibility of group labelling 210  
 Visibility of the catch radius 180  
 Visibility of the direction arrow 223  
 Visible layers 113  
 Visible layers and storeys 510  
 Visible planning 48  
 Visible storeys 126  
 VRML scene 62

## - W -

W button 222  
 Wall 457  
 Wall and roof intersection 339  
 Wall axes 223  
 Wall breakthrough 287

- Wall construction and levels 231
  - Wall corners 288
  - Wall dimensioning-editing 569
  - Wall dimensions 565
  - Wall elemets 231
  - Wall finish 231
  - Wall influence on other components 221
  - Wall input 224, 227
  - Wall introduction 220
  - Wall layer/floor 235
  - Wall layers 220
  - Wall openings 286
  - Wall projection 221
  - Wall property dialogues 235
  - Wall recess 208
  - Wall segmente 221
  - Wall size/position 235
  - Wall surfaces 234
  - Wall trimming 236
  - Wall trimming (L) 236
  - Wall trimming (T) 236
  - Walls 2D representation 234
  - Walls 3D display 221
  - Walls catalogue 231
  - Walls-Dialogue Construction 231
  - Walls-Important shortcut keys 222
  - WETO 68
  - What are component templates? 150
  - What are coordinates 96
  - What do you need coordinates for? 96
  - What is the active layer? 104
  - What is the active projectile? 120
  - When the originals were missing 71
  - Which layers should be created? 112
  - white background 50
  - Whole sheet 48
  - Width 312, 562
  - Width and height measured 180
  - Width surcharge 300
  - Wind shutters 326
  - Window closure 231
  - Window designer 304
  - Window handles 326
  - Window layout 192
  - Window leaf 308
  - Window shutter 294
  - Window sills/roller shutter boxes 300
  - Window surrounds 301
  - Window,Door,Recesses 287
  - Window/door/wall cut-out property dialogues 289
  - Window/door/wall cut-out selection 293
  - Window/door/wall recess component 290
  - Window/door/wall recess labelling 303
  - Window/door/wall recess material 302
  - Window/door/wall recess position 288, 303
  - Window/door/wall recess properties 303
  - Windows 208, 287
  - Windows clipboard 50
  - Windows/doors/wall recess layer/floor 303
  - Windows/doors/wall recesses catalogue 289
  - Windows/doors/wall recesses-General settings 291
  - Windows/doors/wall recesses-The overview moulding 289
  - Windows/doors/wall saving 2D replacement view 298
  - Wings 308
  - With automatic mitre 278
  - With border 278
  - with offset 331
  - With wooden construction 128
  - Without interior roof panelling 395
  - Wooden construction 128, 268, 340
  - Wooden construction of the roof 334
  - Wooden construction View 129
  - Working in 2D view mode 507
  - Working with handles 584
- X -**
- x, y - absolute cartesian 100
  - X3D scene 65
  - x-axis, abscissa 96
  - X-value 227
- Y -**
- y-axis, ordinate 96
  - Y-value 227
- Z -**
- z-coordinates 39
  - Zero point 98, 193
  - Zeros 560
  - Zones 103, 386

Zoning 28  
Zoom 174  
Zoom and pan (move) 176  
Zoom section 176  
Zoom to element 174, 176  
Zoom with the mouse scroll wheel 176